

# LOYD Psací stůl/Písací stôl

Montážní/Montážny návod

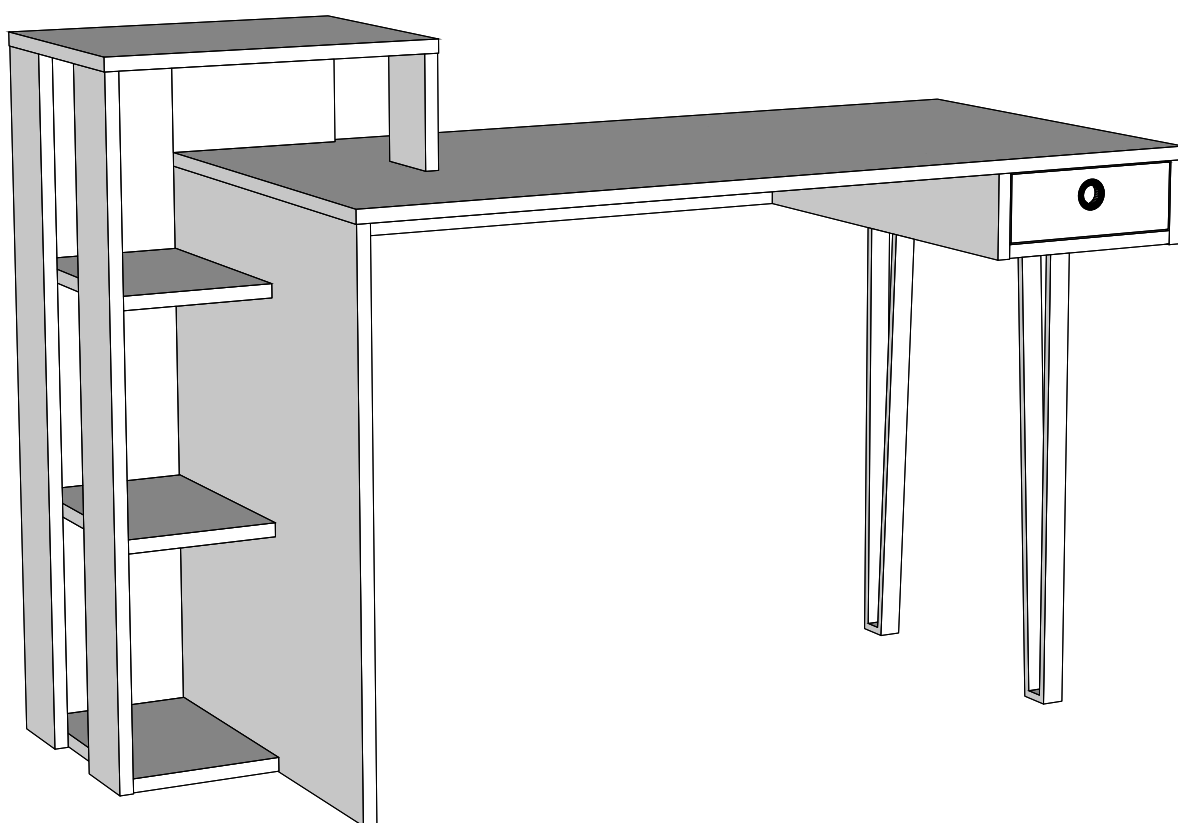



Tento produkt před odesláním podléhá přísné kontrole kvality.

Před montáží zkontrolujte produkt a ujistěte se, že nechybí nebo nejsou poškozeny žádné montážní díly. Pokud jste zakoupili více než jeden produkt, montujte je prosím postupně, aby nedošlo k pomíchání dílů. Nejprve očistěte všechny díly vlhkým hadrem.



Pro běžné čištění stačí opět vlhký hadřík.

Ačkoli je zboží pečlivě zabaleno, může dojít k jeho poškození během transportu. V takovém případě nás neváhejte kontaktovat.

Používejte produkt jen k účelům, ke kterým je určen. Nevystavujte produkt nadměrnému horku, zimě ani vlhkosti.



Tento produkt pred odoslaním podlieha prísnej kontrole kvality.

Pred montážou skontrolujte produkt a uistite sa, že nechýbajú alebo nie sú poškodené žiadne montážne diely. Ak ste zakúpili viac ako jeden produkt, montujte ich prosím postupne, aby nedošlo k pomiešaniu dielov.

Najprv očistite všetky diely vlhkou handričkou. Na bežné čistenie stačí opäť vlhká handrička.



Hoci je tovar starostlivo zabalený, môže dôjsť k jeho poškodeniu počas transportu. V takom prípade nás neváhajte kontaktovať.

Používajte produkt len na účely, na ktoré je určený.

Nevystavujte produkt nadmernému teplu, zime ani vlhkosti.

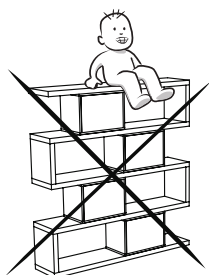

Varování

Převrácení nebo pád produktu může způsobit vážná zranění. Produkt musí být vždy připevněn na zeď přiloženým upevňovacím materiálem.

Nástroje pro upevnění na zeď nejsou součástí balení, pro různé typy zdí jsou potřebné různé druhy nástrojů. Použijte nástroj vhodný pro vaši zeď.



Varovanie

Prevrátenie alebo pád produktu môže spôsobiť vážne zranenia. Produkt musí byť vždy pripevnený na stenu priloženým upevňovacím materiálom.

Nástroje na upevnenie na stenu nie sú súčasťou balenia, na rôzne typy múrov sú potrebné rôzne druhy nástrojov. Použite nástroj vhodný na vašu stenu.



Liebe Kunden,

alle unsere Produkte werden von der Designphase bis zur Produktions- und Auslieferungphase sorgfältig überprüft und getestet, sodass sie jahrelang haltbar bleiben.

Gentile Cliente,

questo prodotto è stato ideato e realizzato con attenzione per il design, sottoponendolo a tutti i tipi di test e controlli prima di essere messo in vendita.



Vor dem Aufbau nehmen Sie bitte alle Teile aus der Packung raus und kontrollieren Sie sie anhand des Montagehandbuchs, ob sie vollständig sind. Falls Sie mehr als ein Produkt gekauft haben sollten, achten Sie bitte darauf, dass die Teile nicht ineinander überlaufen. Deswegen ist es wichtig, dass ein Produkt nach dem anderen aufgebaut wird.

Verificare l'idoneità della parete prima di procedere al fissaggio. Prima dell'assemblaggio controllare che tutti i componenti ed accessori siano presenti come indicato nella lista accessori.



Bitte wischen Sie vor dem Aufbau jedes Teil mit einem feuchten Tuch ab.

Prima dell'assemblaggio pulire tutti i componenti con un panno umido. Questa procedura dovrà essere eseguita ogni qualvolta si vorrà pulire il prodotto.



Obwohl unsere Produkte sorgfältig kontrolliert und abgepackt werden, kontaktieren Sie uns bitte, falls bei der Lieferung ein Problem gegeben haben sollte. Sie können uns per E-Mail unter [support@decortie.com](mailto:support@decortie.com) oder telefonisch unter +90 850 255 1736 erreichen.

Sebbene tutti i prodotti siano realizzati e imballati con cura, qualche volta può capitare che qualche componente si danneggi durante il trasporto. In tale caso per favore verifica il materiale mancante o danneggiato e non esitare a contattarci. Puoi inviare una mail a [support@decortie.com](mailto:support@decortie.com) o telefonarci al numero +90 850 255 1736

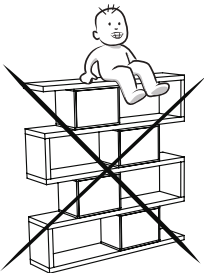

Bitte benutzen Sie Ihr Möbel nicht außer dem Verwendungszweck. Im Falle eines Verwendungszweckänderung kontaktieren Sie bitte zuerst uns. Die Möbel können beschädigt werden, wenn sie zu hohen oder zu niedrigen Temperaturen sowie Feuchtigkeit ausgesetzt werden. Bitte vermeiden Sie diese Fälle.

Non utilizzare il prodotto per altri usi.

Non mettere in contatto questo prodotto con fonti di calore, freddo ed umidità perché si potrebbe danneggiare.



## SICHERHEITSHINWEIS

Durch Umkippen der Möbel können lebensgefährliche Situationen auftreten. Die Umkipf-Gefahr zu verhindern, sollte Ihr Möbel mit dem beigefügten Apparat an die Wand befestigt werden. Da die Wandbaustoffe variieren, wurde ein Wandmontageset nicht mitgeliefert. Bitte informieren Sie sich über Ihren Wandbaustoff und besorgen Sie das entsprechende Wandmontageset, das Sie bei einem Heimwerkermarkt finden können.

## AVVERTENZA

Se il mobile si ribalta può causare lesioni da compressione serie o fatali. Per prevenire il rischio che il mobile si ribalti, quest'ultimo deve essere fissato permanentemente alla parete.

Gli accessori per il fissaggio alla parete non sono inclusi perché pareti di materiali diversi richiedono tipi diversi di accessori di fissaggio. Usa sistemi di fissaggio adatti alle pareti della tua casa. Per maggiori dettagli, rivolgiti a un rivenditore specializzato.

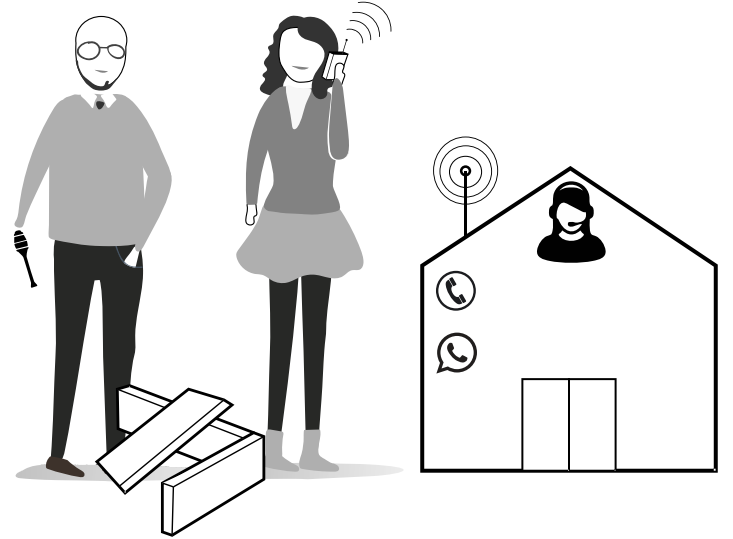
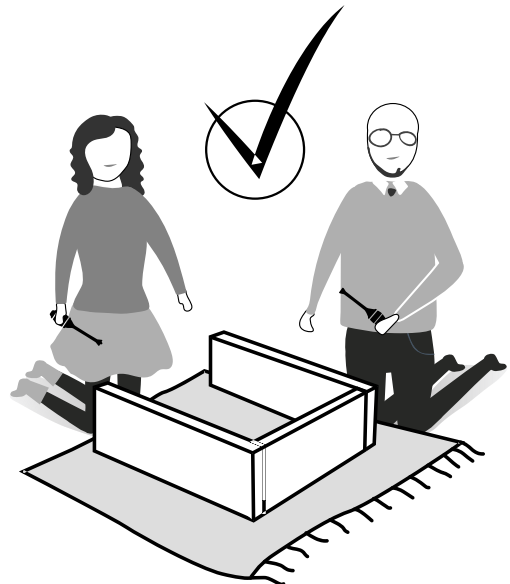
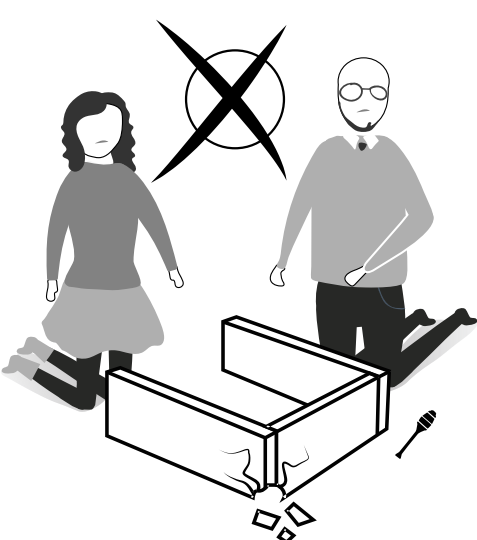
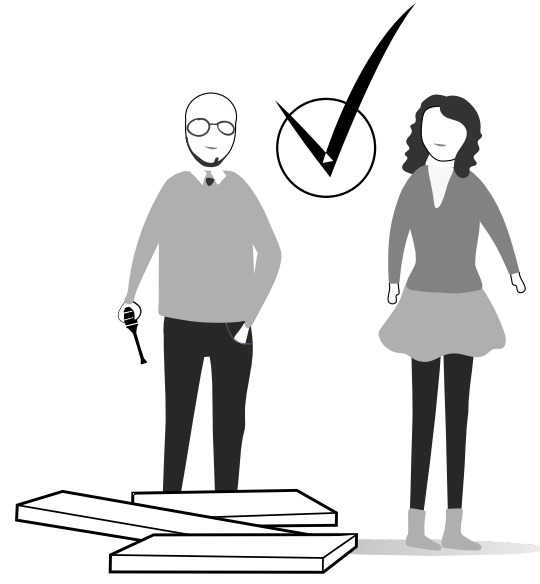
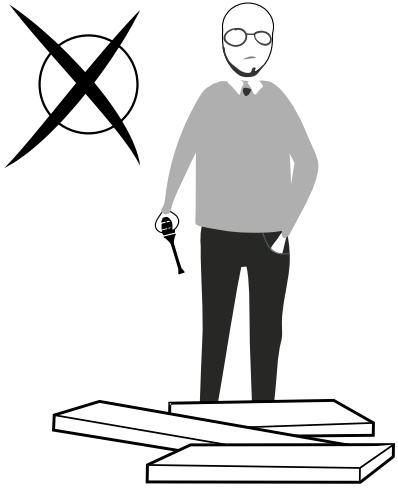

## Upozornění/Upozornenie

Minifix je spojovací materiál tohoto výrobku. Než začnete pracovat, prohlédněte si pozorně nákresy níže.

Minifix je spojovací materiál tohto výrobku. Než začnete pracovať, pozrite si pozorne nákresy nižšie.

A04

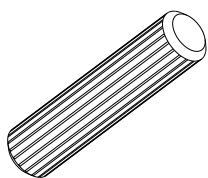

A23

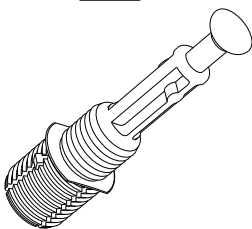

A22

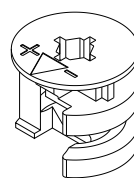

1

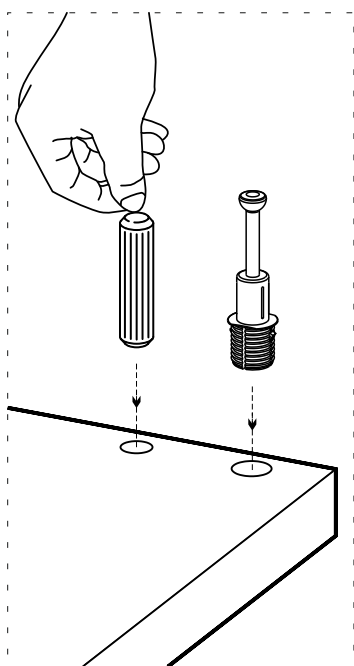

2

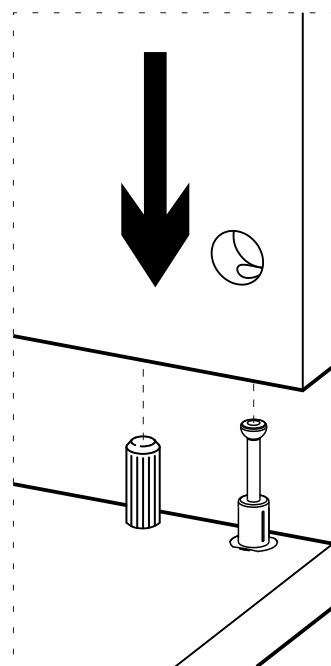

3

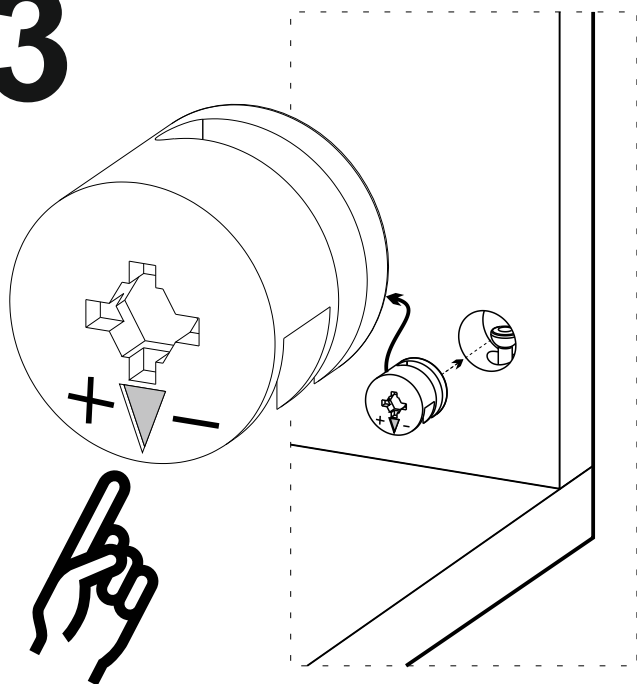

4

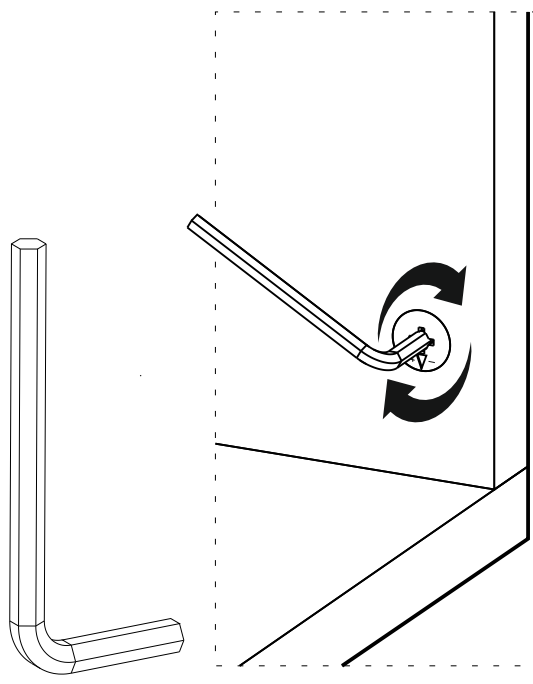

Před montáží si pozorně prohlédněte nákresy níže  
Pred montážou si pozorne prezrite nákresy nižšie

**A13**



**1**

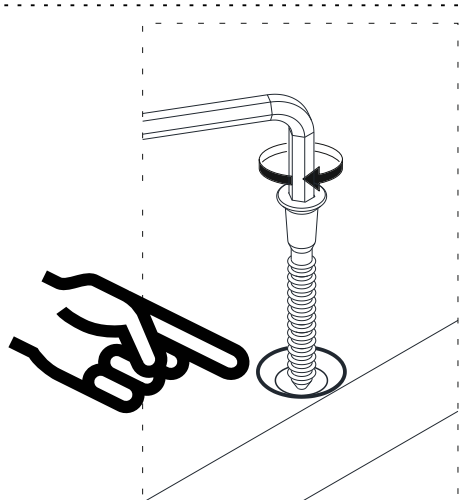

**1**

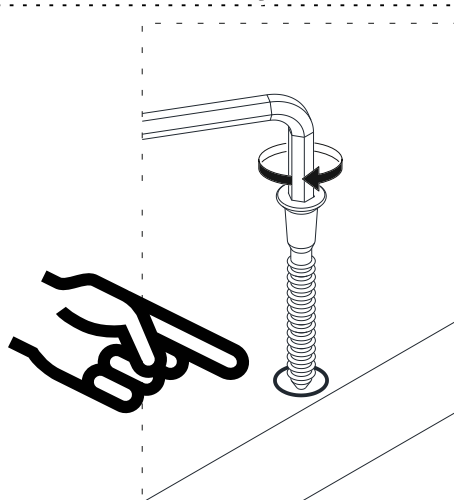

**2**

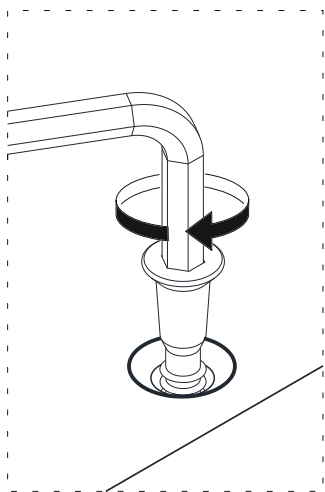

**2**

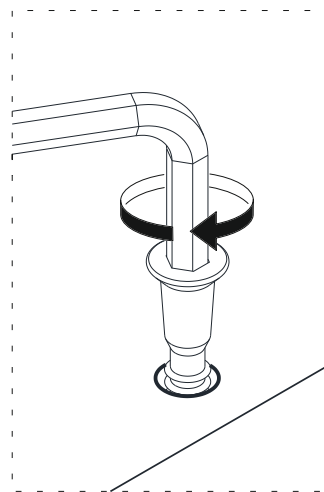

**3**

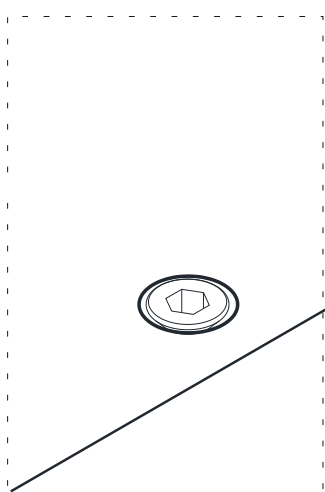



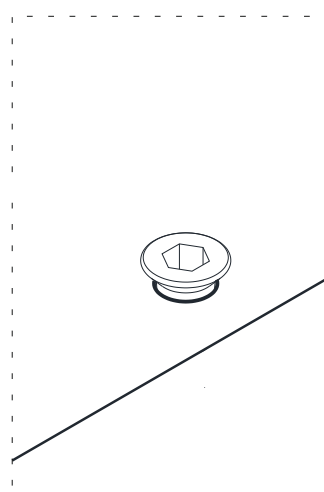





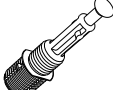
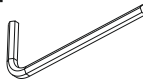
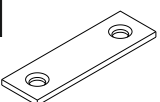

**3**

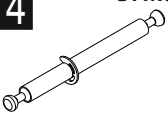
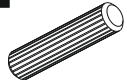

Postupujte přesně podle kroků v návodu.  
Umístěte díly přesně podle návodu.

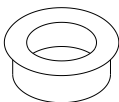
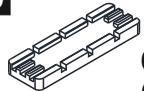
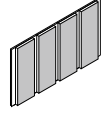

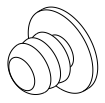
## Seznam dílů/Zoznam dielov

<b>A22</b> Minifix k18  36x	<b>A23</b> Minifix M10  32x	<b>A12</b> Allen  2x	<b>Z41</b> Dgs  2x	<b>A18</b> 3,5x18  2x
<b>A13</b> 50mm  16x	<b>A14</b> DFM6-86  2x	<b>A04</b> Ø8  28x	<b>A16</b> DbØ8  2x	<b>A17</b> 4X50  2x
<b>B15</b> 15 (black)mm  4x	<b>B10</b>  4x	<b>Z37</b> 35mm pygk (Black)  1x	<b>A08</b> 5mm  C1-2x C2-2x	<b>Y03</b> Ctpb  4x
<b>Z36</b> 30x10x628  2x	<b>Z54</b> Pp1501  2x	<b>A06</b> 18mm  C1-31x C2-20x		

Postupujte presne podľa krokov v návode. Umiestnite diely presne podľa návodu.

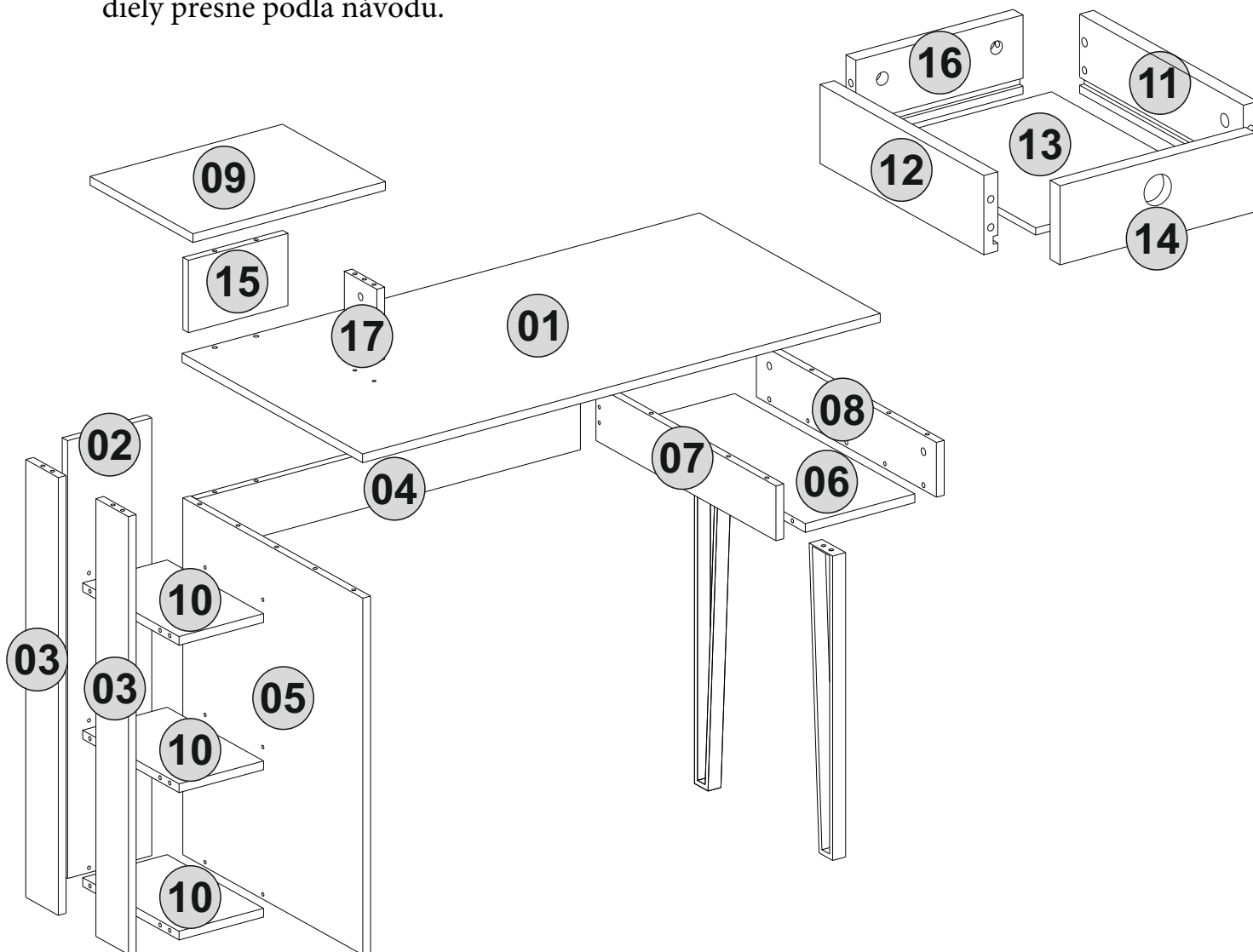

# 1. krok

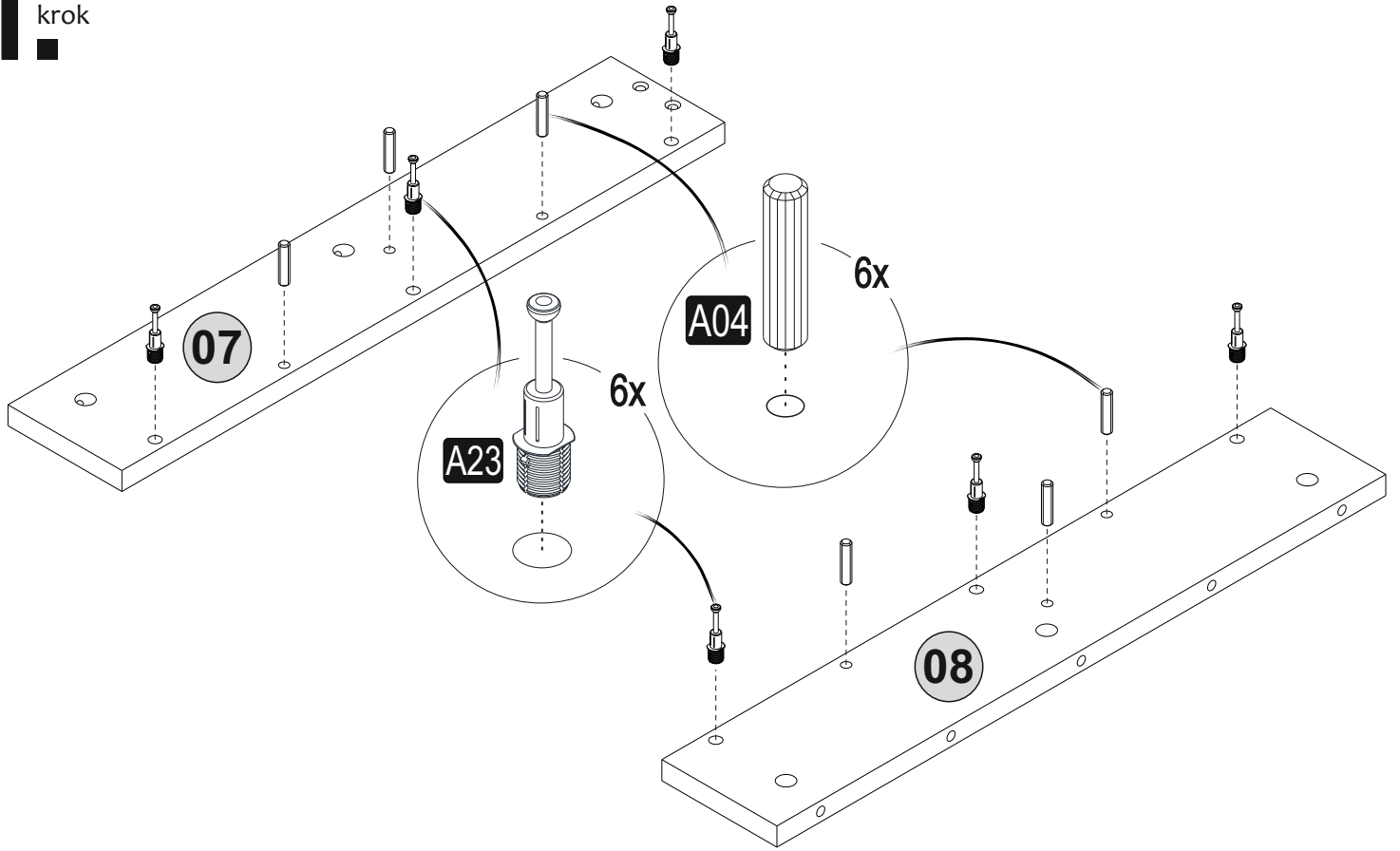

# 2. krok

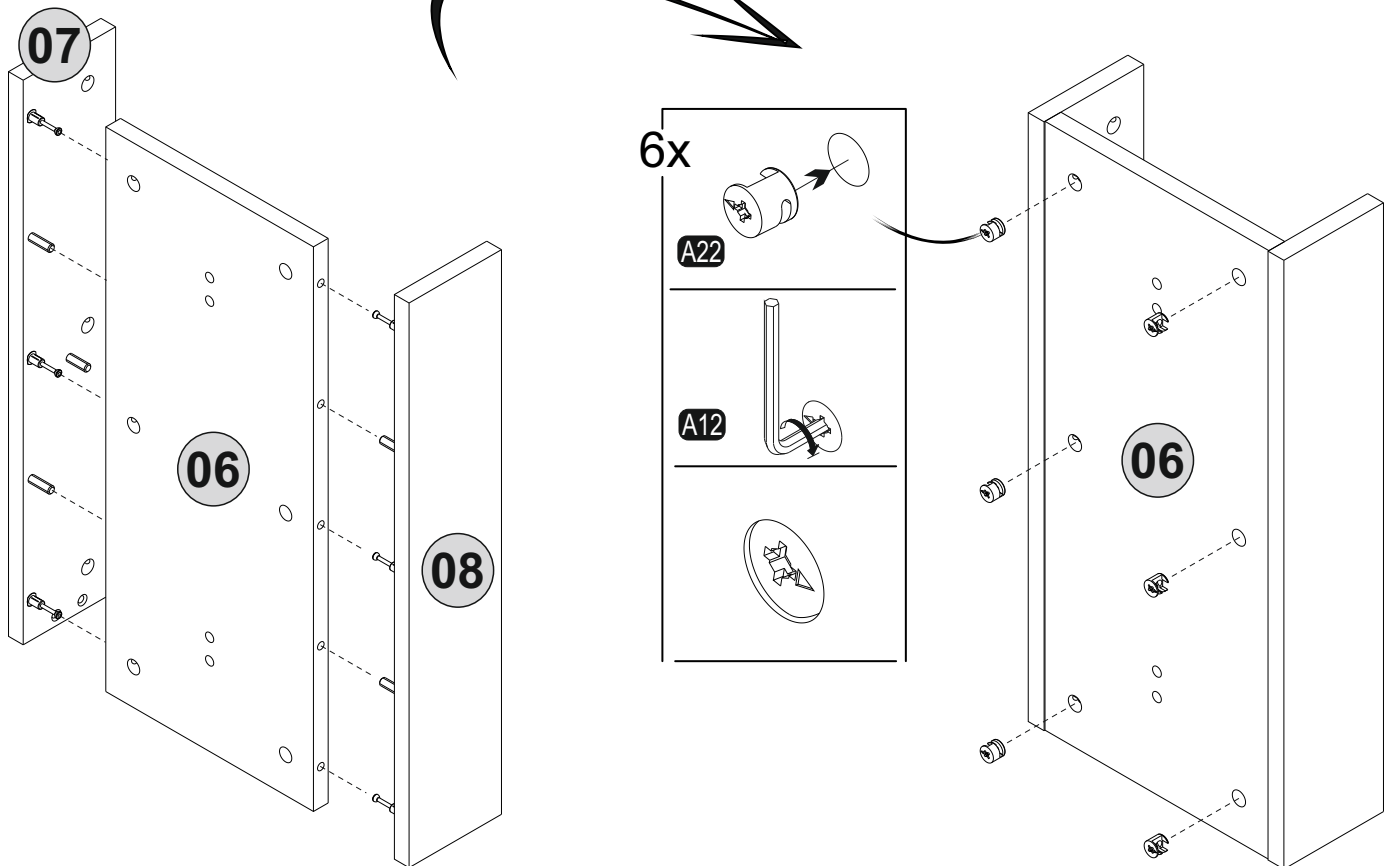



# 3. krok

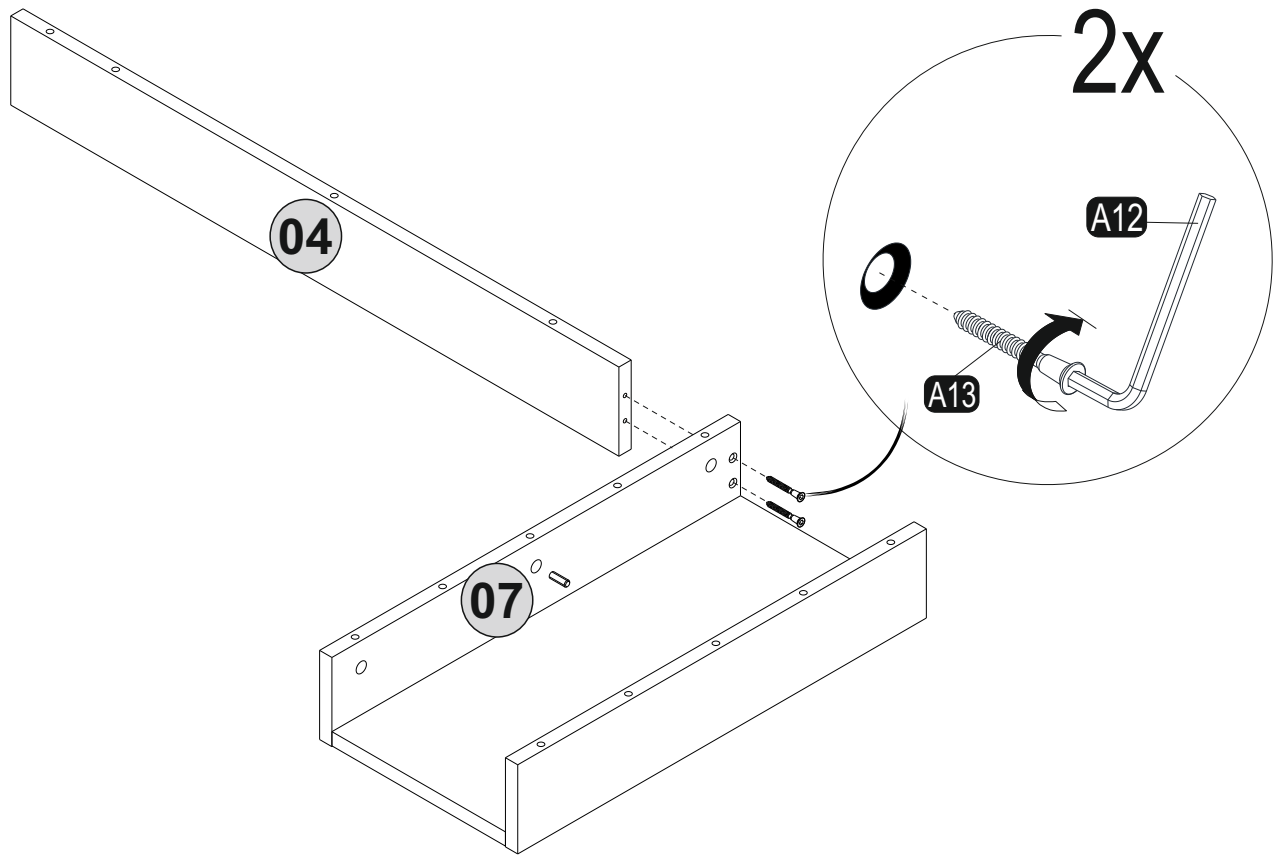

# 4. krok

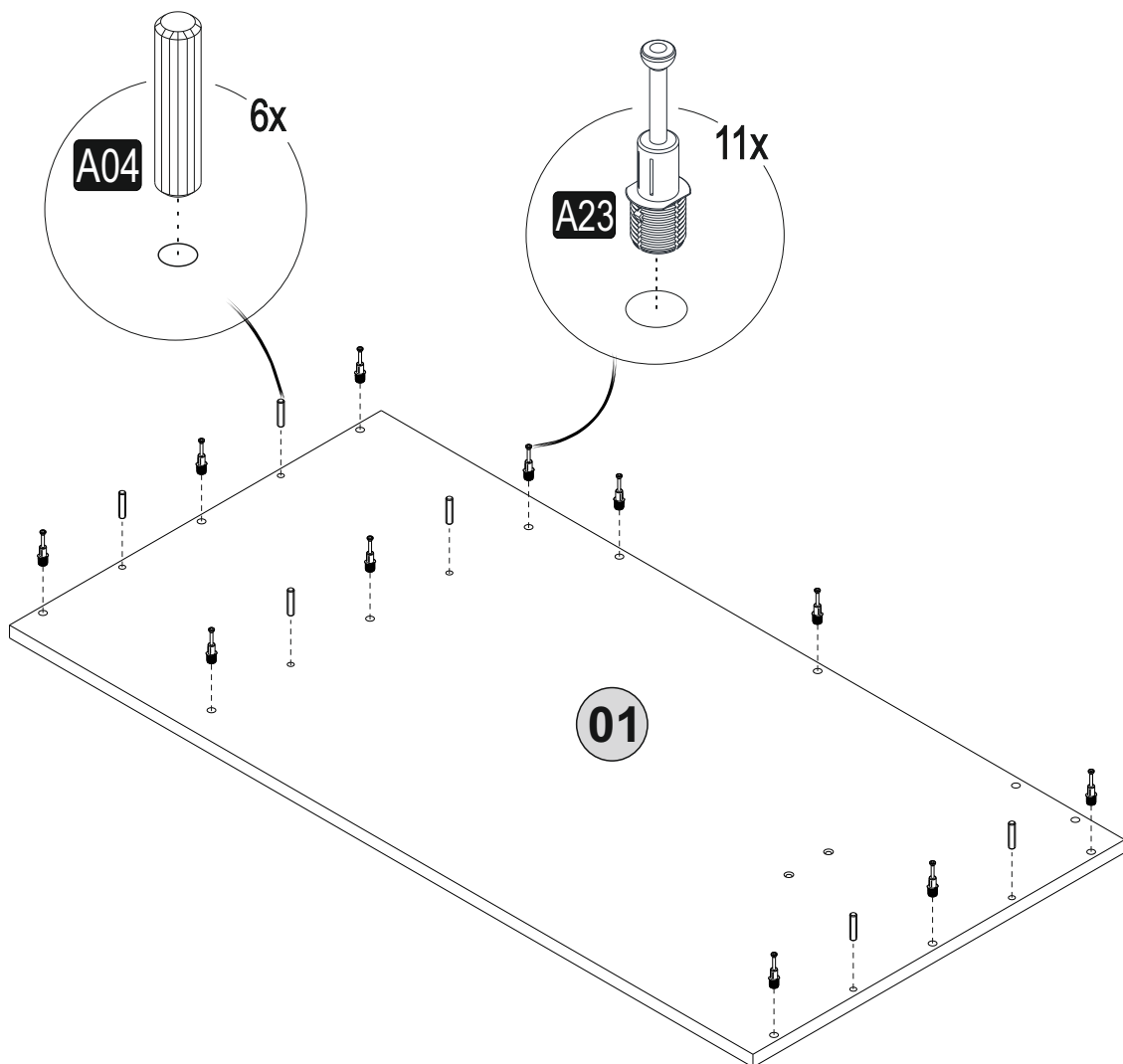

# 5. krok



Doporučujeme sestavovat a přemísťovat produkt 2 dospělým osobám.

Odporúčame zostavovať a premiestňovať produkt 2 dospelým osobám.

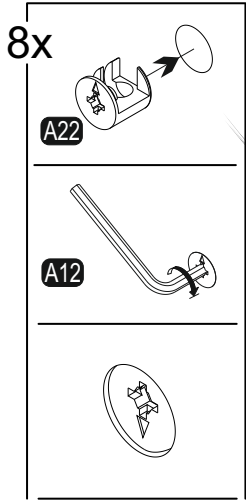
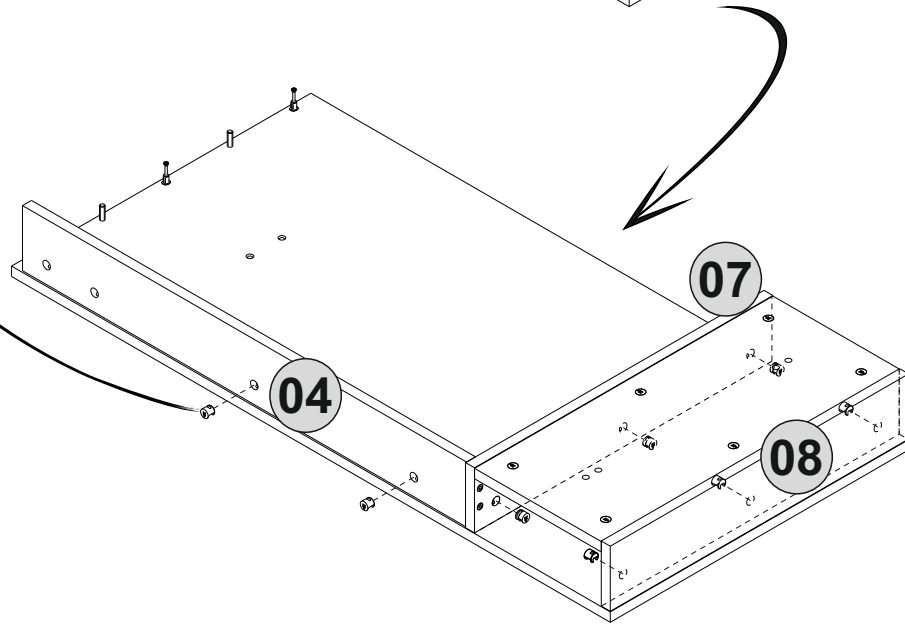
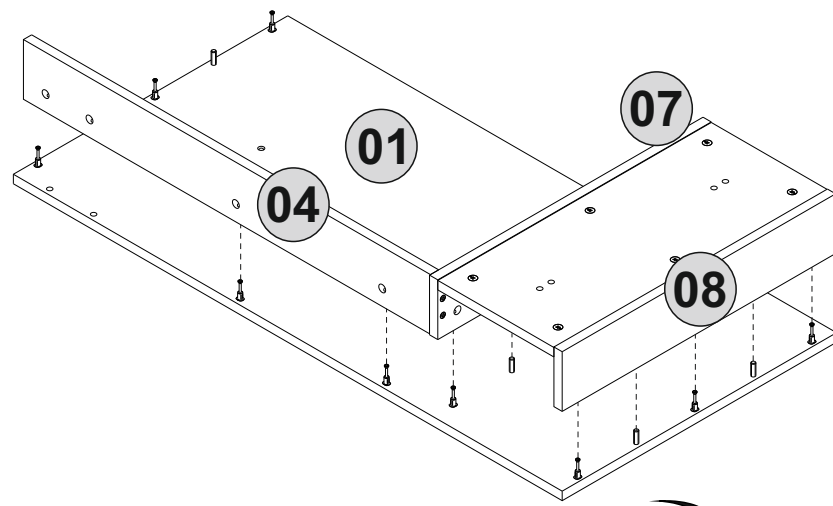

# 6. krok

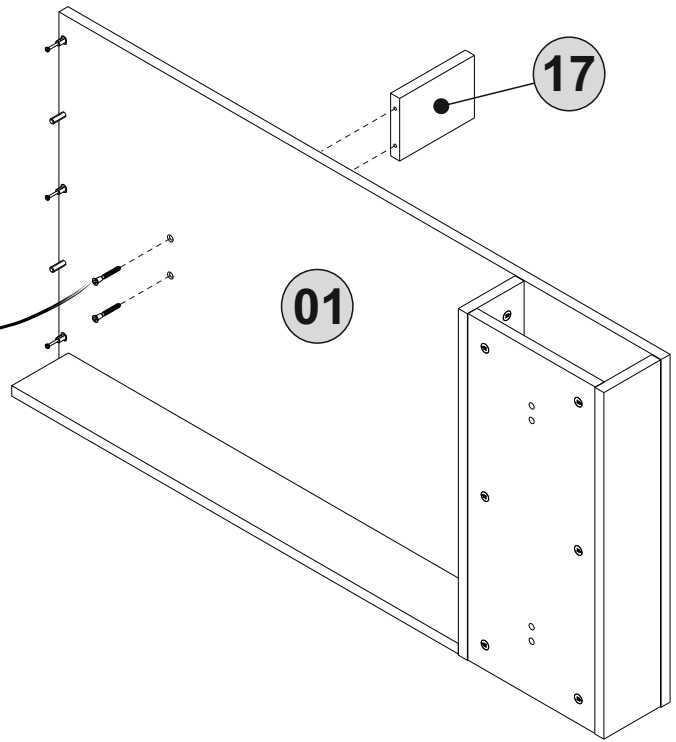
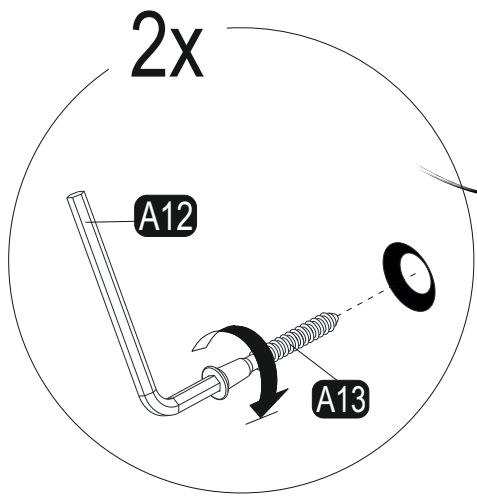

# 7. krok

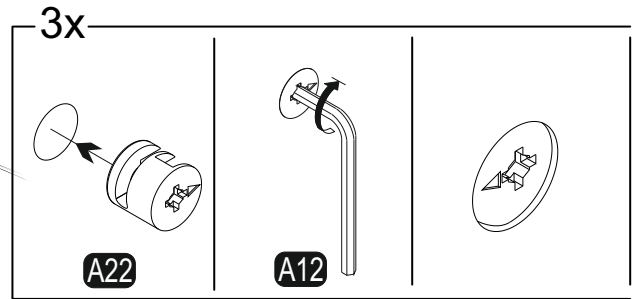
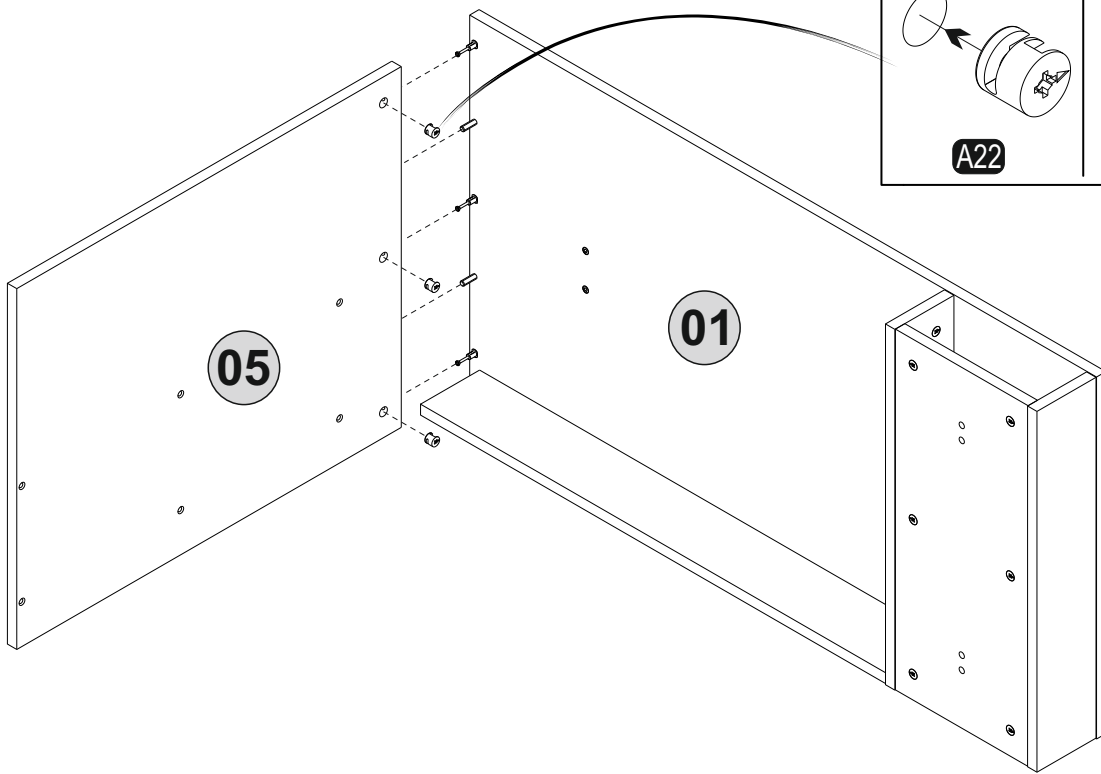

# 8. krok

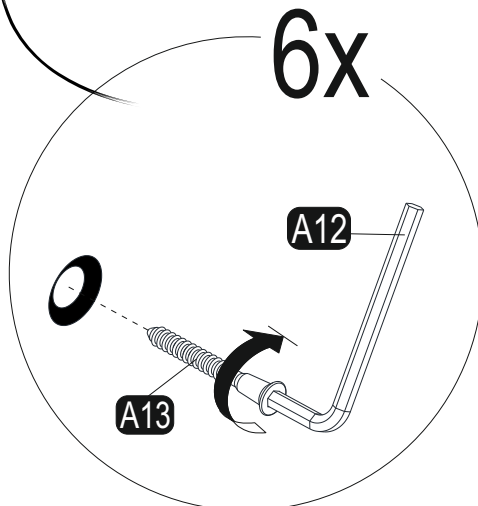
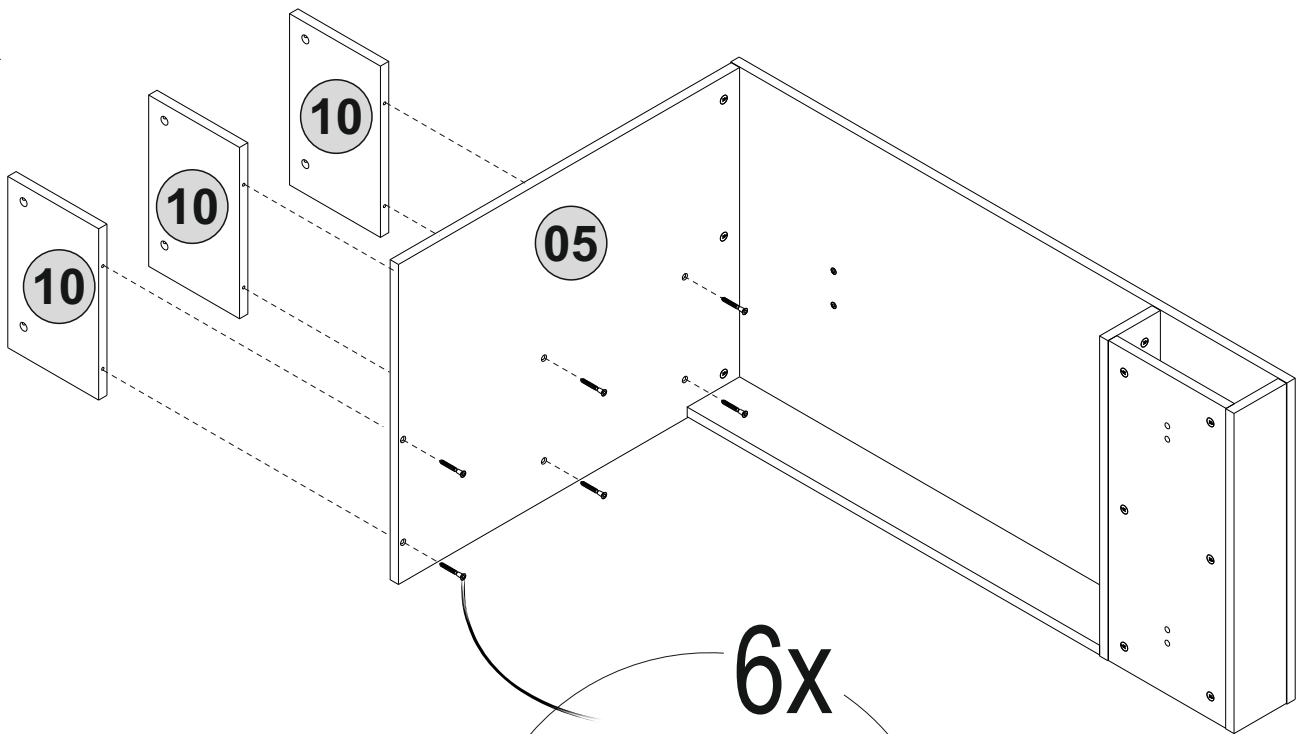

# 9. krok

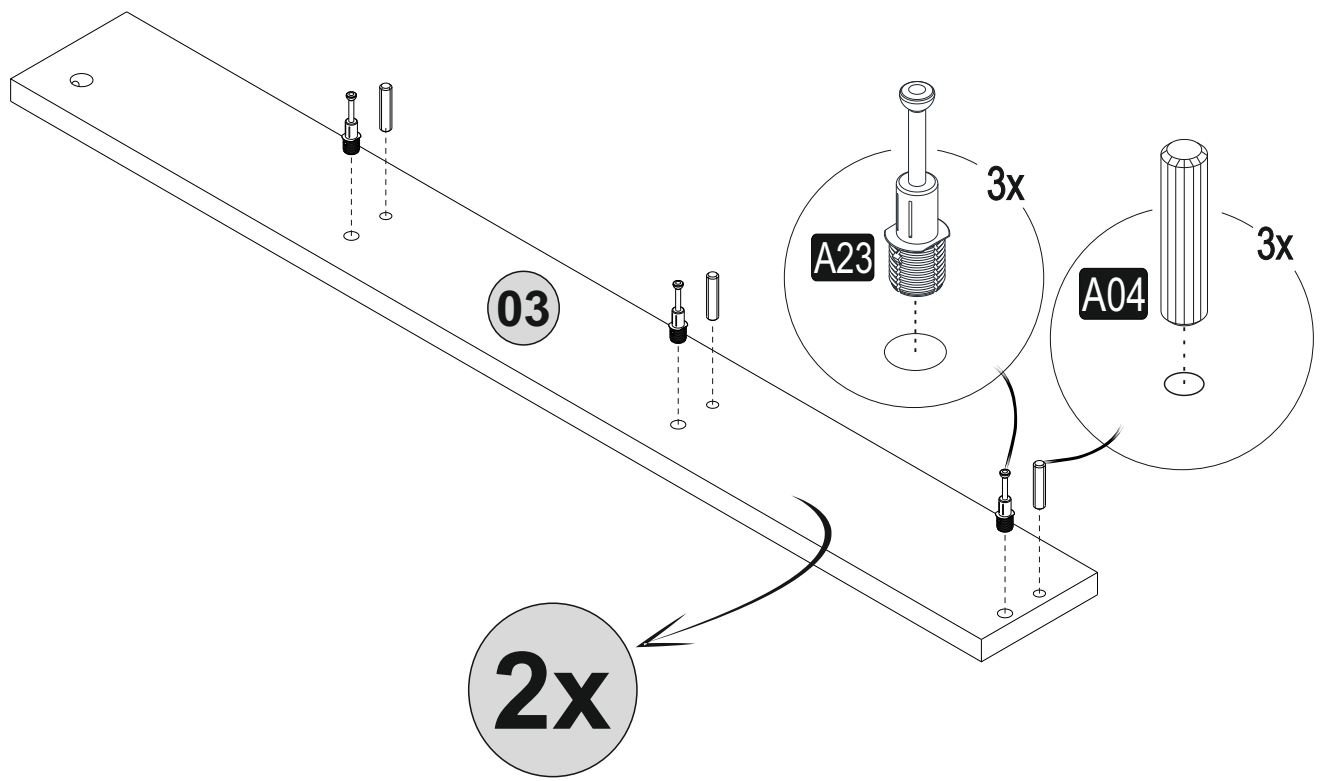

# 10. krok

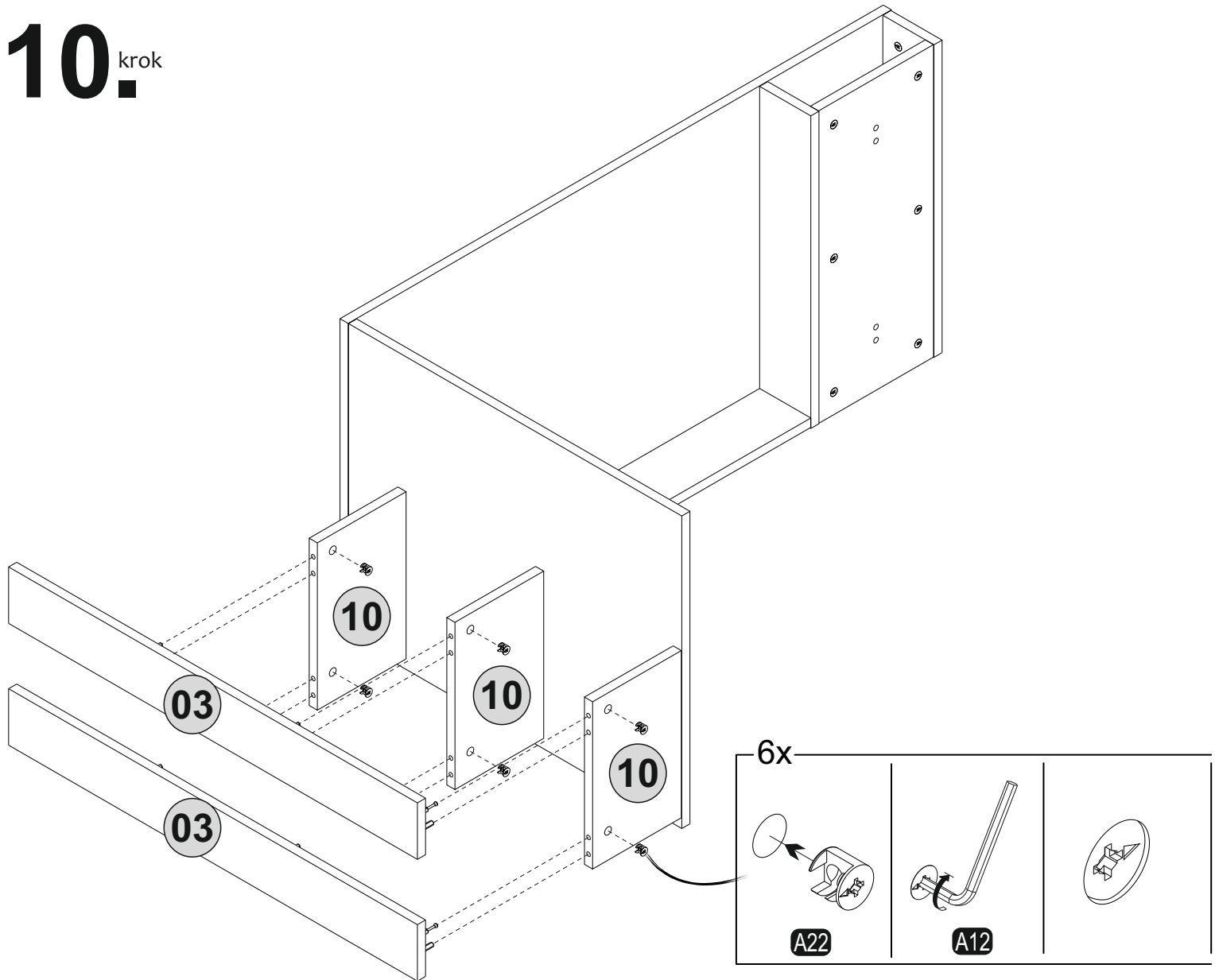

# 11. krok

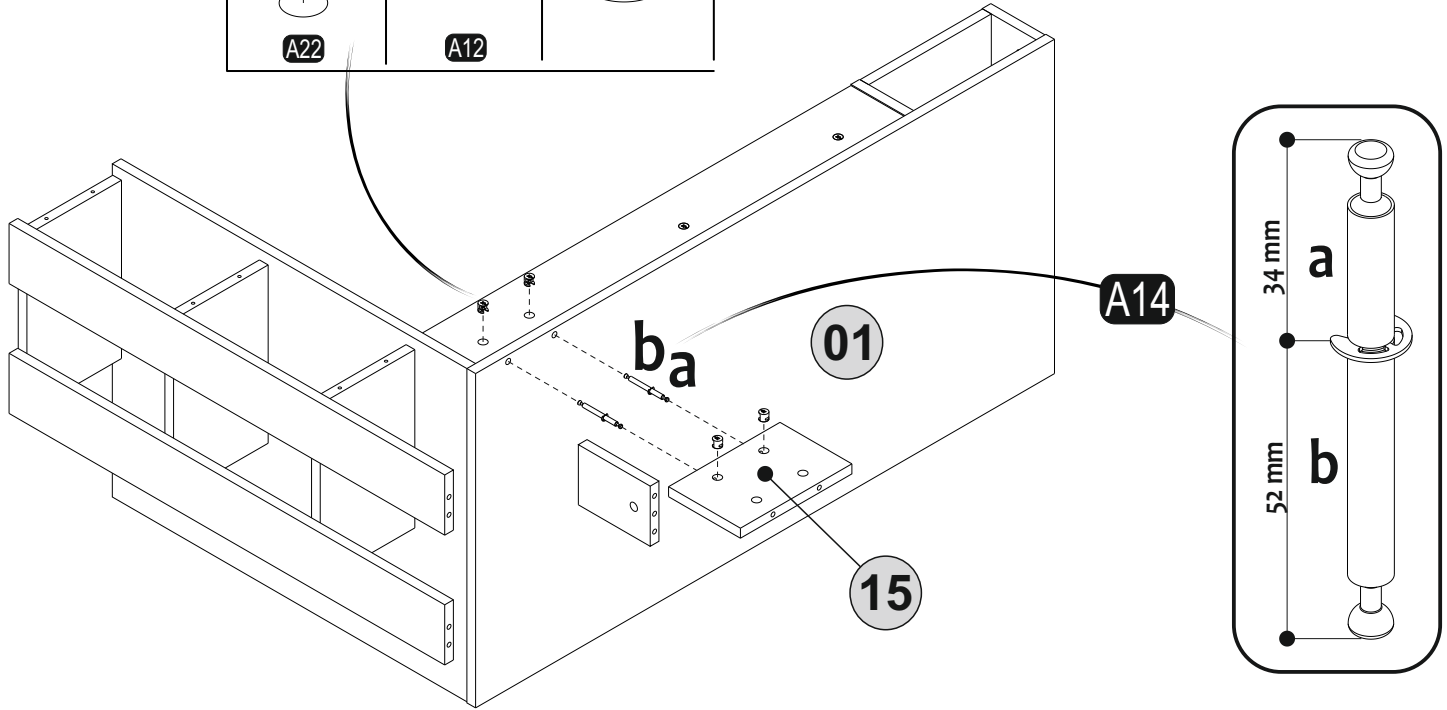
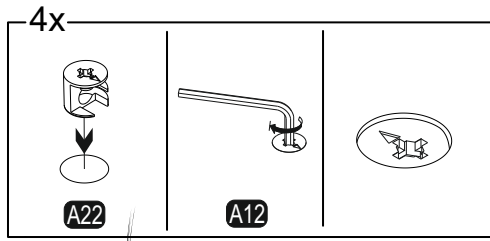

# 12. krok

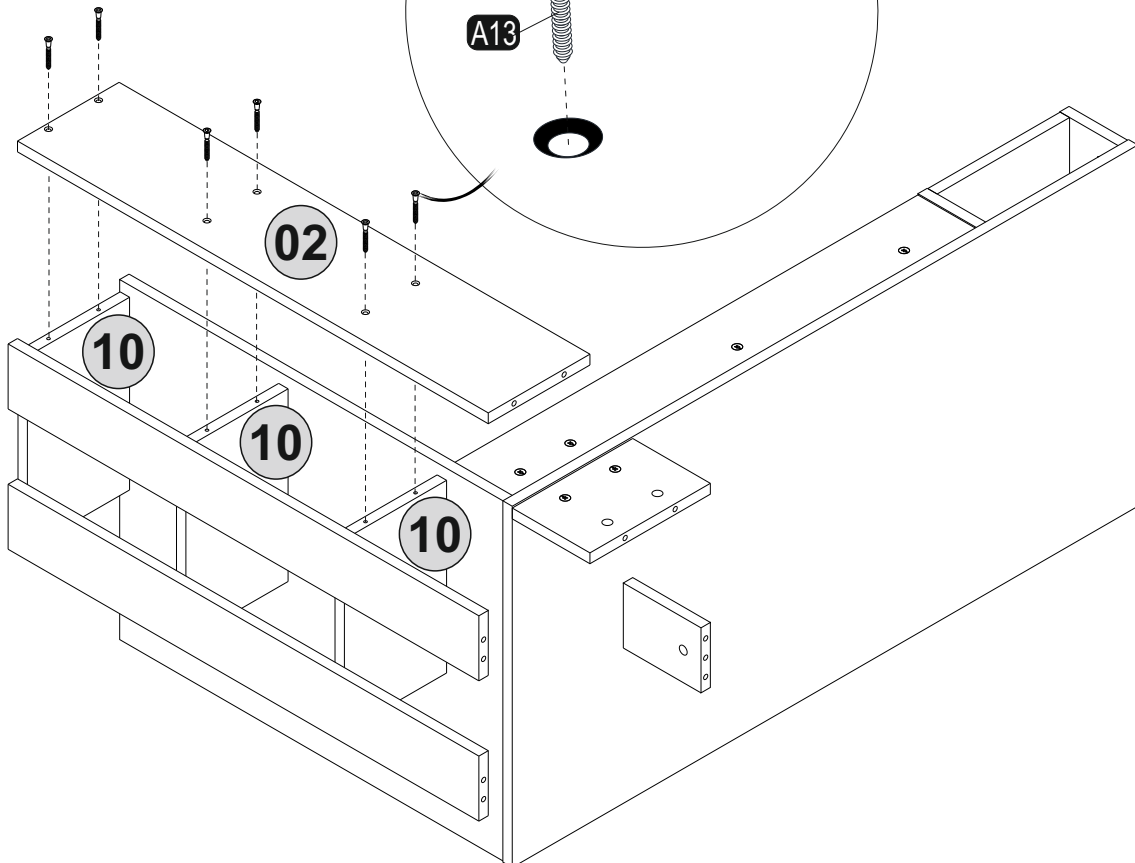
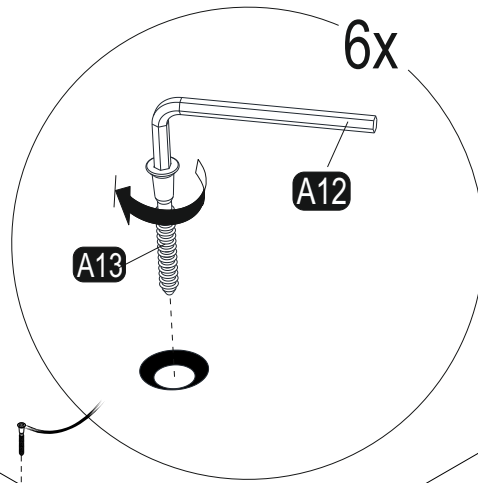

# 13. krok

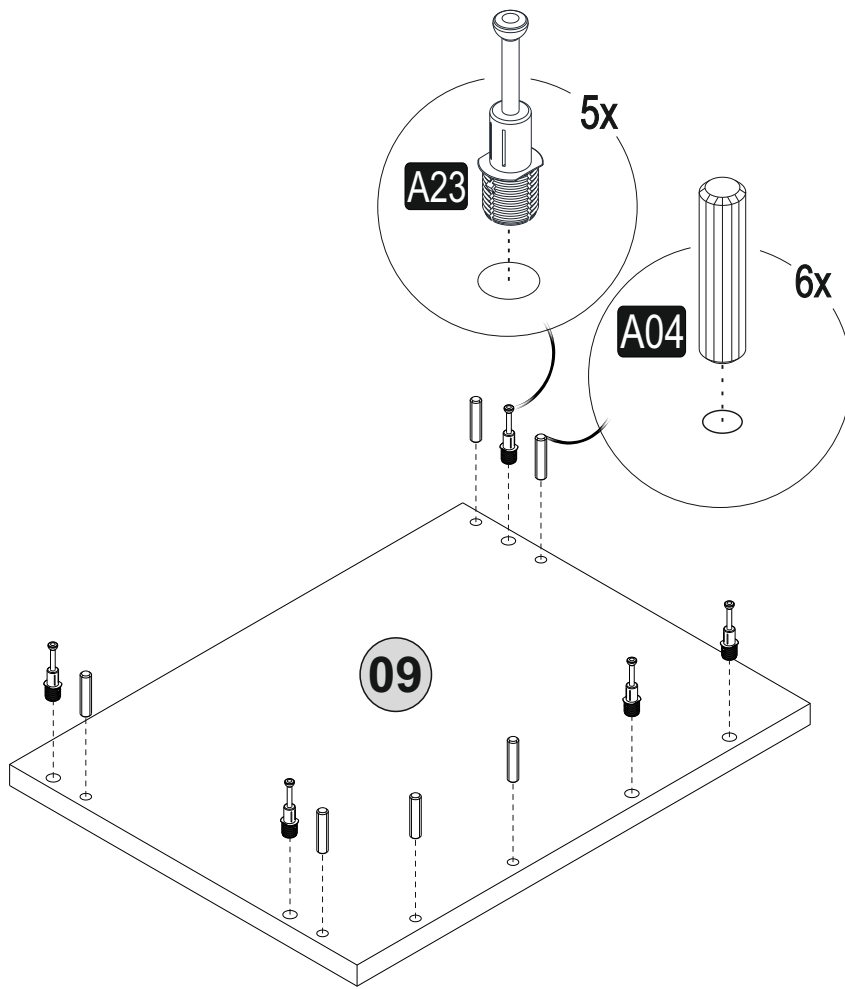

# 14. krok

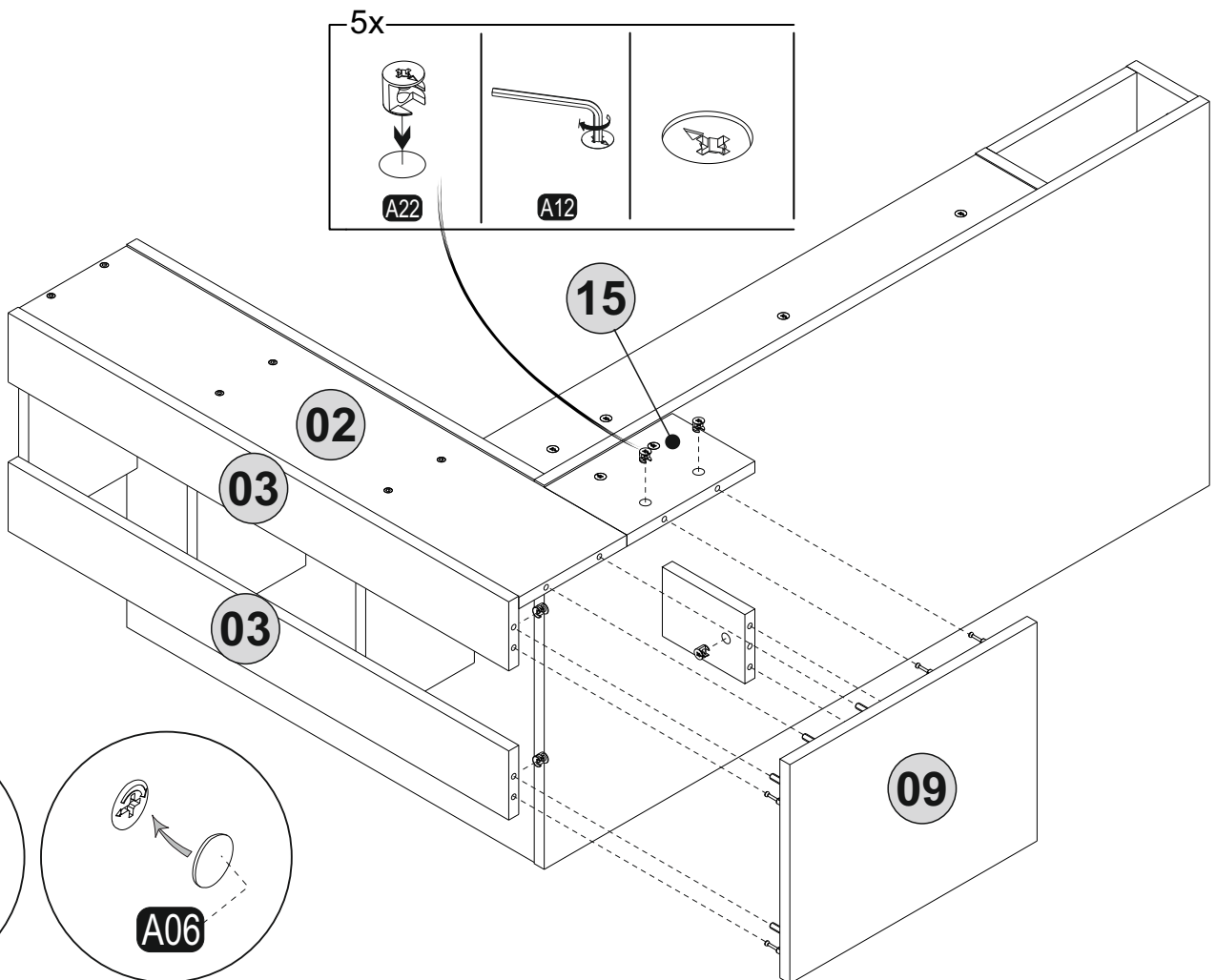

# 15. krok

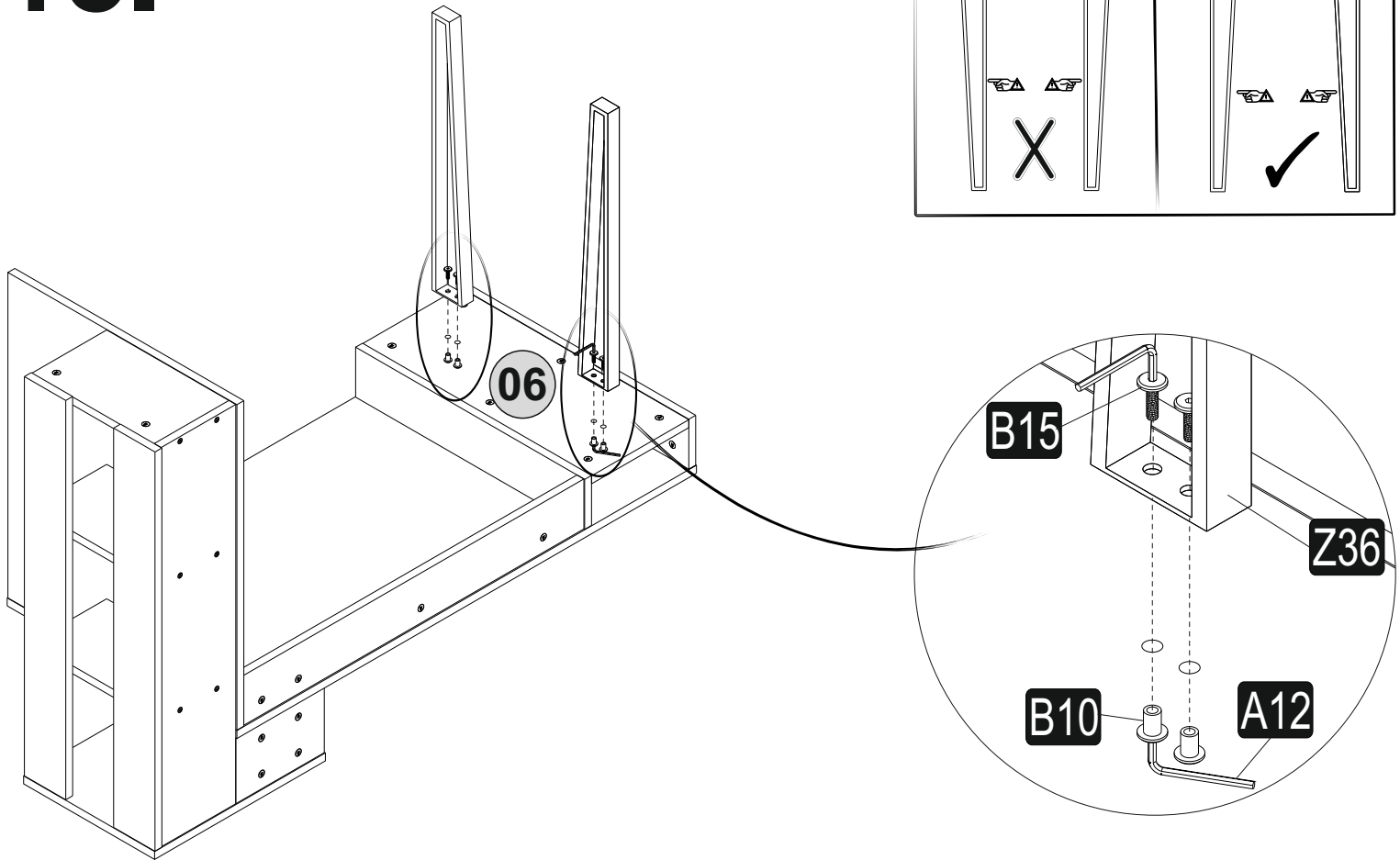

# 16. krok

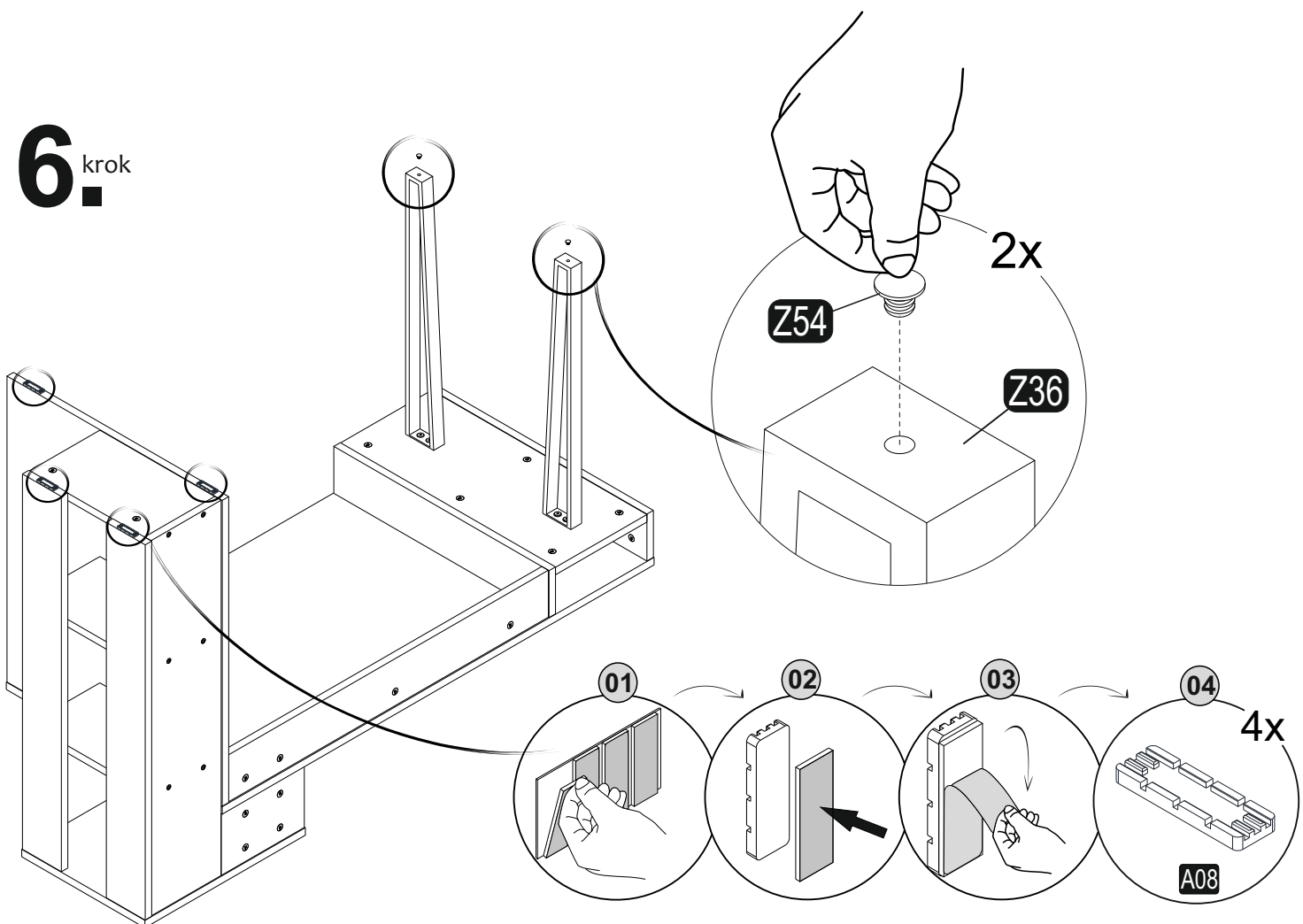

# 17. krok

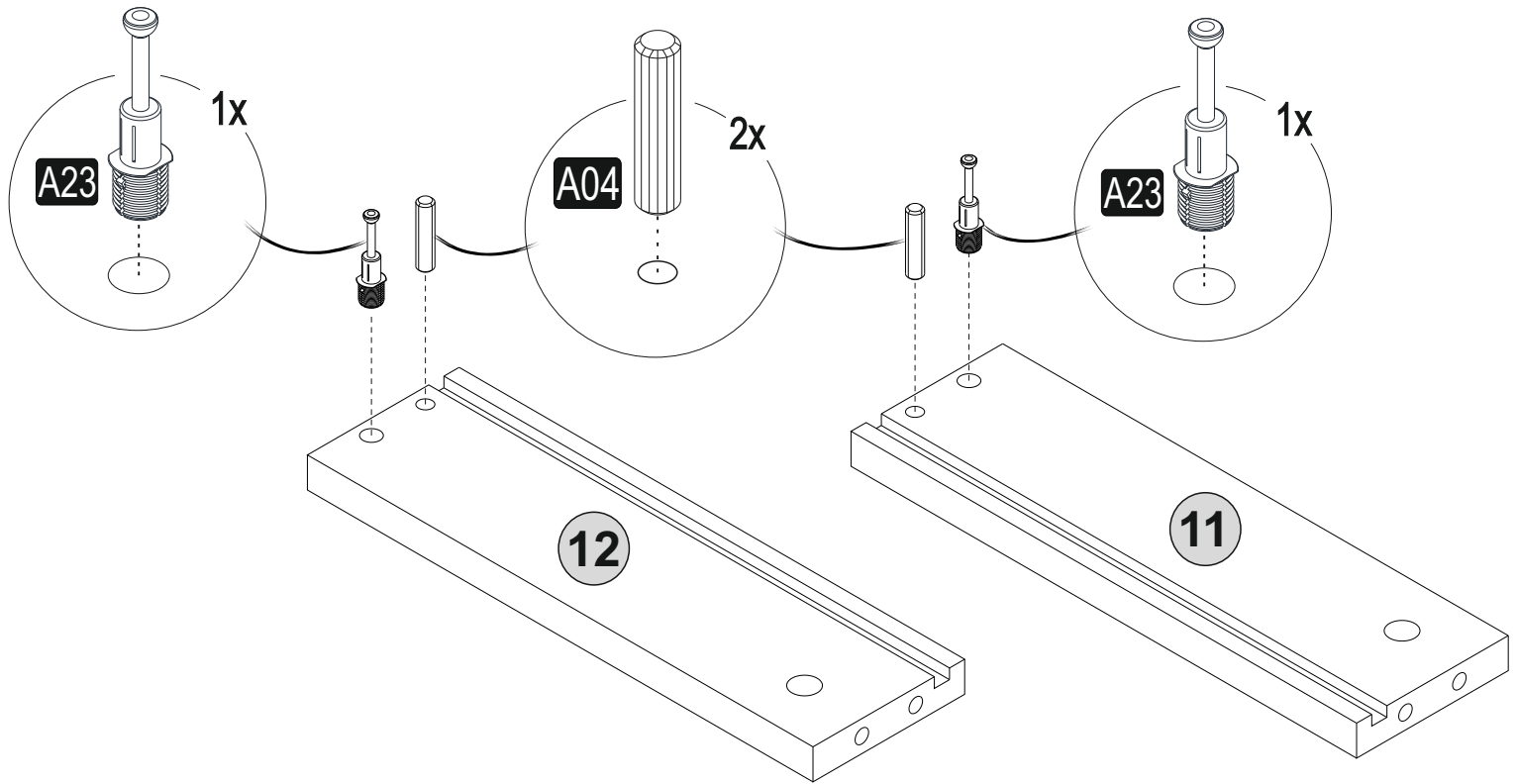

# 18. krok

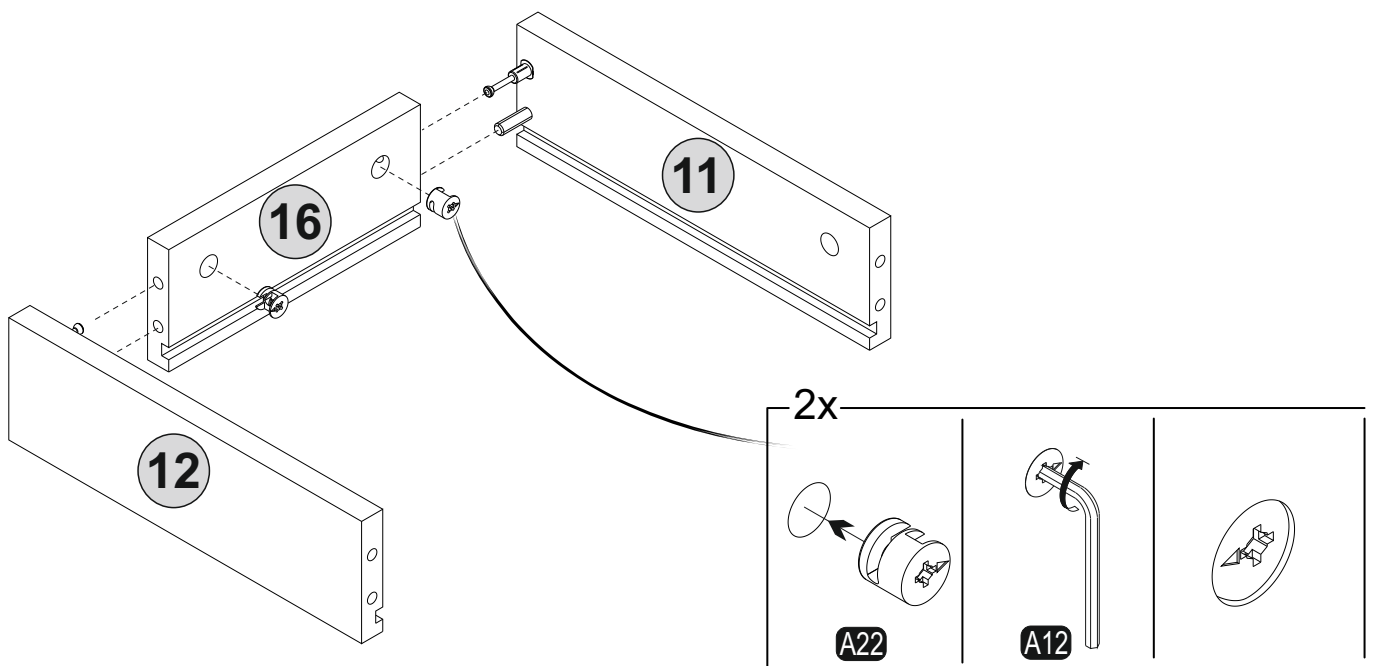



# 19. krok

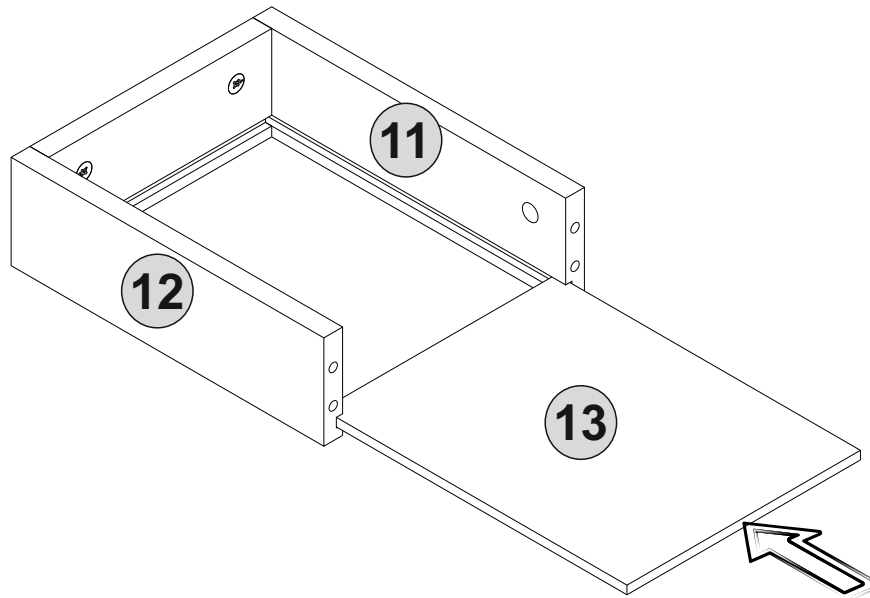

# 20. krok

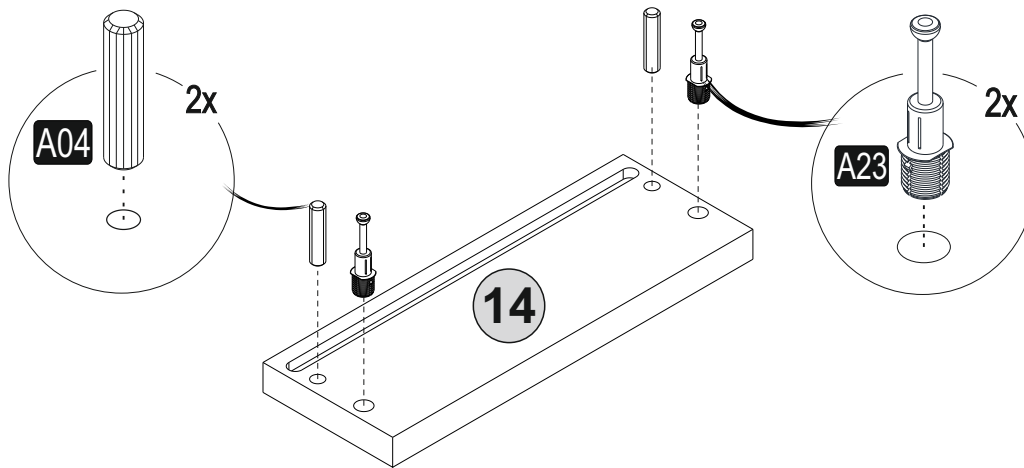

# 21. krok

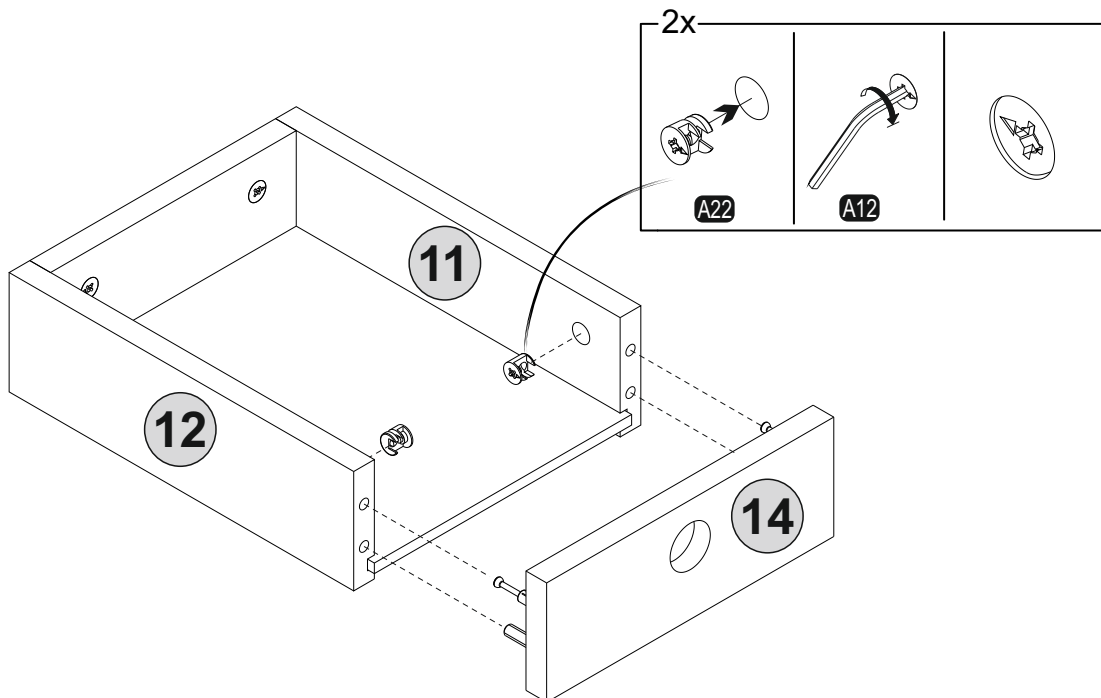

# 22. krok

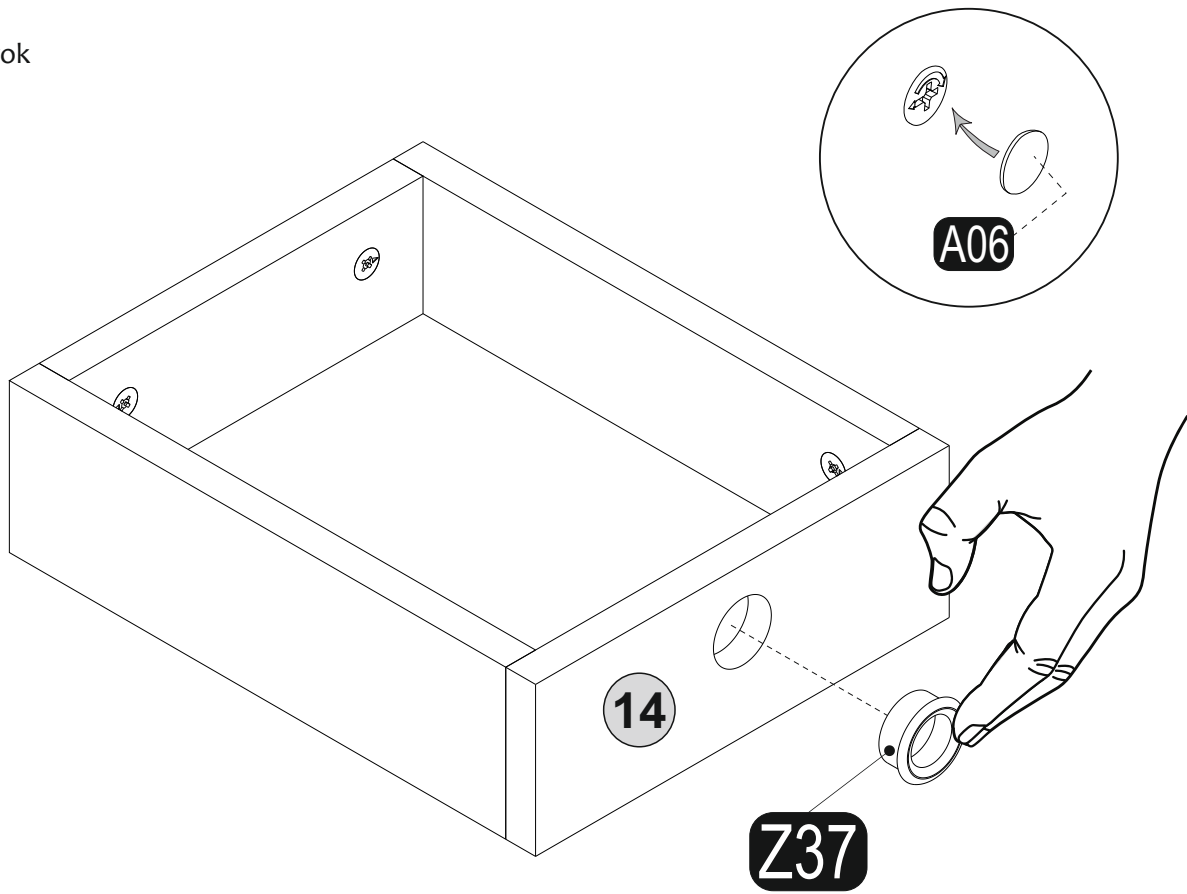

# 23. krok

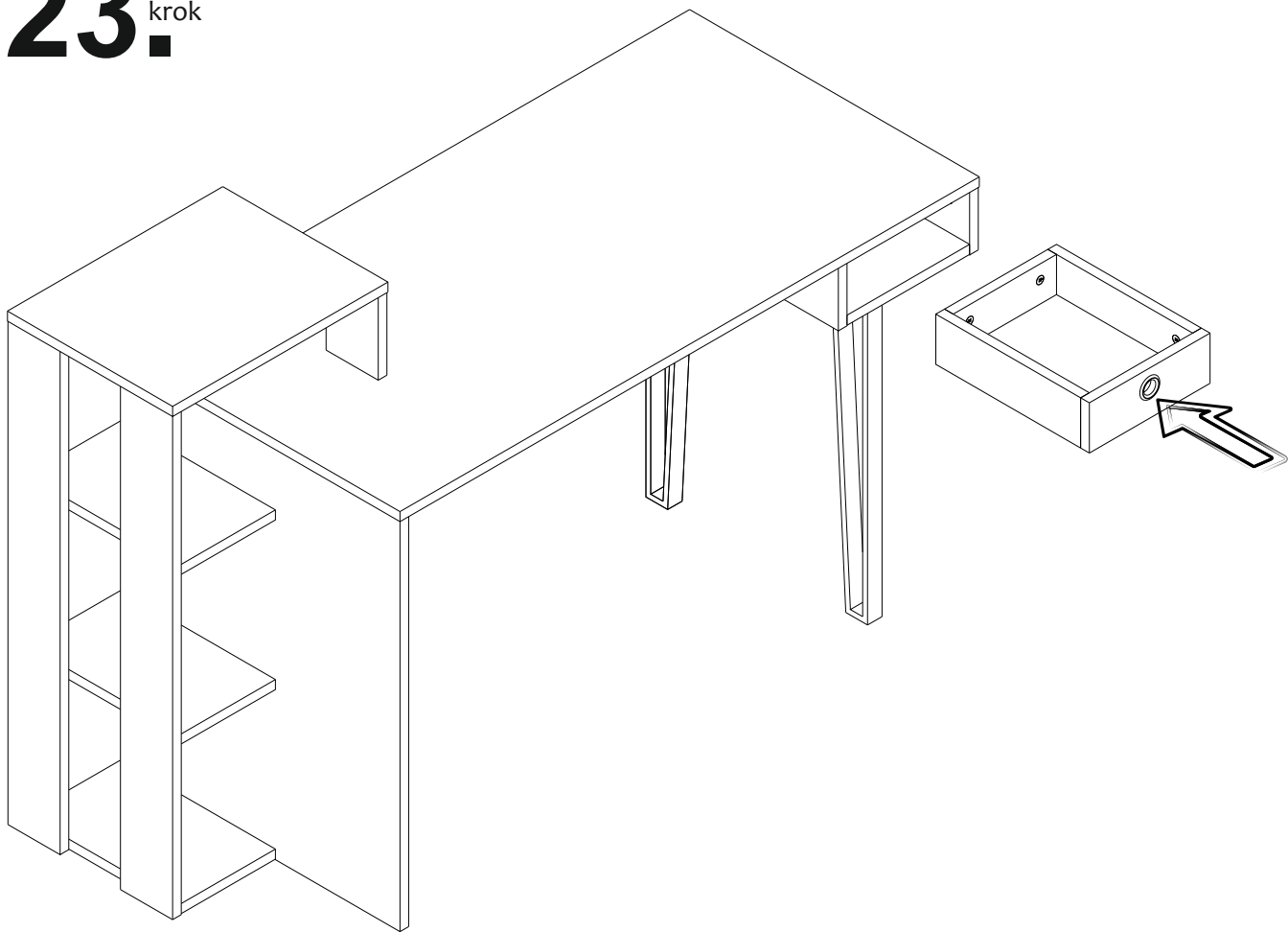

# 24. krok

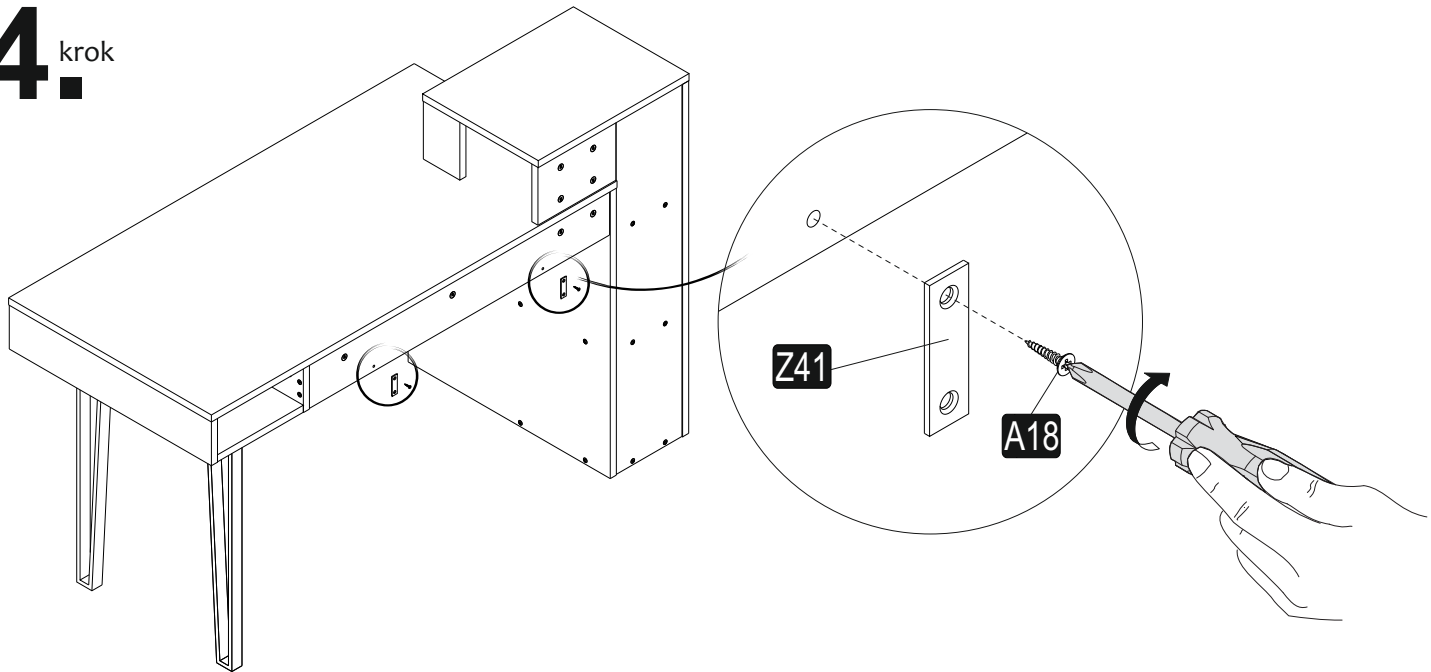

# 25. krok

