

HERNÍ STŮL/HRACÍ STŮL GAME

MANUAL DE MONTAJE
NOTICE DE MONTAGE - ASSEMBLY MANUAL
MONTAGEANLEITUNG - MANUAL DE
MONTAGEM - MONTAGE INSTRUCTIES
MONTÁŽNÍ/MONTÁŽNY NÁVOD

5022 DGAME

V.01 - 07/21

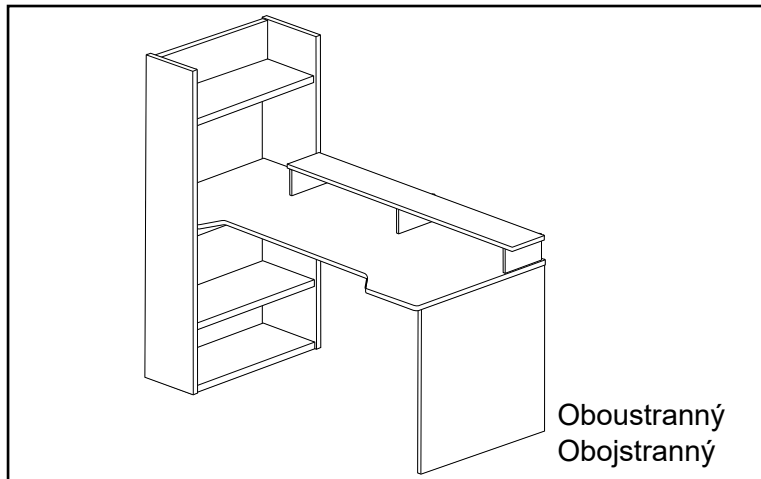

Oboustranný
Obojstranný

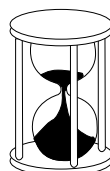

≈ 2h



x2

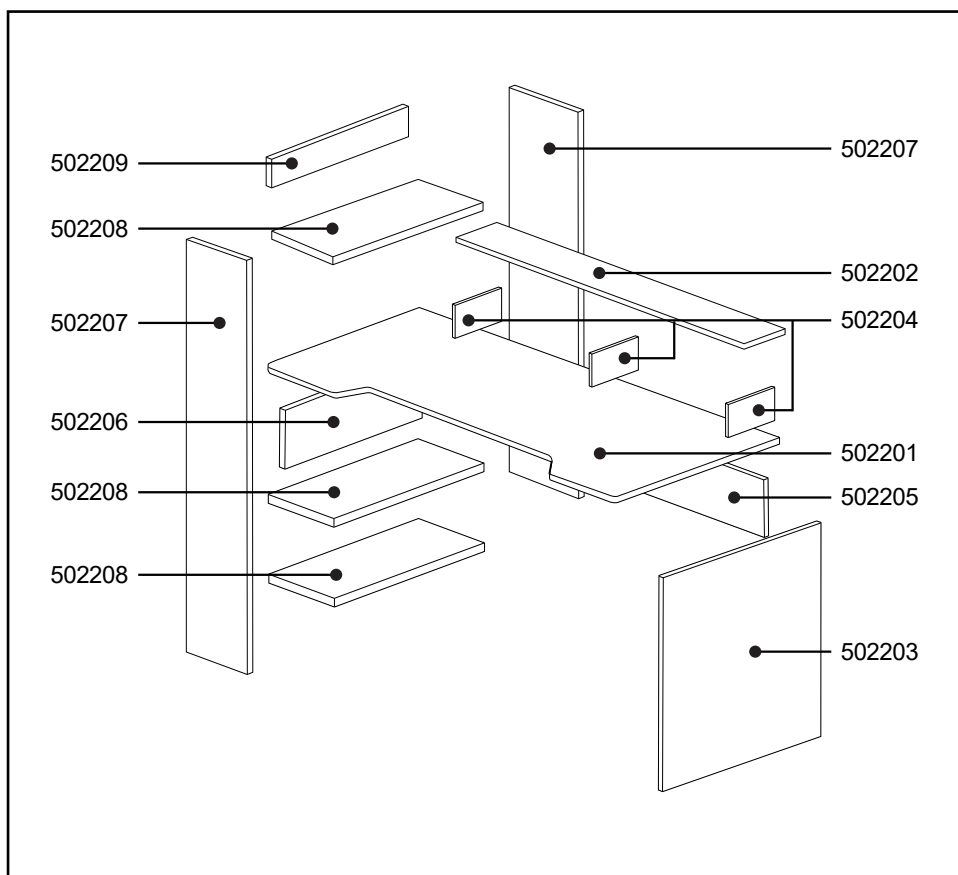
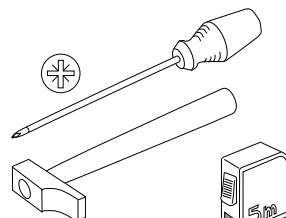

ANTES DE EMPEZAR
CONSULTE LOS CONSEJOS
PARA EL MONTAJE.

AVANT DE COMMENCER
CONSULTEZ LES
INSTRUCTIONS DE MONTAGE.

BEFORE STARTING REFER TO
THE ASSEMBLY ADVICE.

VOR DEM BEGINN EMPFIEHLT
ES SICH AUFMERKSAM DIE
HINWEISE ZUR MONTAGE ZU
LESEN.

ANTES DE COMEÇAR
CONSULTE OS CONSELHOS
PARA A MONTAGEM.

RAADPLEEG VOORDAT U
BEGINT HET MONTAGE-
ADVIES.

Než začnete montovat, přečtěte si
pozorně montážní návod.

Než začnete montovať, prečítajte
si pozorne montážny návod.

x24	x24	x40	x21	x6	x3	x3	x14	x5	x10	x1	x1	x4	x2	x2	x1
PE845	EX16	CL830	TE17AN	TSM	SKM16	TCK0311	T8AN	TP3515	T5AN	COLA	ECG	TP3525	TP3540	TEMB18C	EA2020
x1	x1														
TL200	SAG														

ČESKO

Upozornění
Pozorně si přečtěte montážní návod
Připravte si všechny montážní díly
Zkontrolujte všechny díly a dodané součástky Připravte si potřebné nástroje
Pracujte na dostatečně velkém prostoru
Údržba
Opatrně očistěte všechny montážní díly
Používejte měkký, čistý hadřík a jemně mýdlovou vodu

Nikdy nedotahujte šrouby příliš velkou silou. Šrouby dotáhněte po krátké době užívání. Uchovejte montážní návod. V případě chybějícího dílu, usnadní návod jeho identifikaci.

Nikdy nepoužívejte abrazivní předměty jako brusný papír atd. Nenamáčejte nábytek ani ho nevystavujte nadměrné vlhkosti.

FRANCAIS

INSTRUCTIONS DE MONTAGE:
 1-LISEZ ATTENTIVEMENT LA NOTICE DE MONTAGE.
 2-REPEREZ LES PIECES QUI COMPOSENT VOTRE MEUBLE.
 3-REGROUPEZ ET VERIFIEZ LES FERRURES FOURNIES.
 4-DOTEZ-VOUS DES OUTILS NECESSAIRES.
 5-PREPREZ UN ESPACE DE MONTAGE.

CONSEILS D'ENTRETIEN:
 1-ENLEVEZ SOIGNEUSEMENT LA POUSSIERE.
 2-HUMIDIFIEZ UN CHIFFON DOUX ET PROPRE AVEC DE L'EAU LEGEREMENT SAVONNEUSE.

LES MEUBLES CONTENANT DES PANNEAUX A BASE DE BOIS (PANNEAUX DE PARTICULES, PANNEAUX DE FIBRES, CONTREPLAQUE...) PEUVENT EMETTRE DES SUBSTANCES POLLUANTES DANS L'AIR INTERIEUR. IL EST AINSI RECOMMANDÉ, APRES L'INSTALLATION DU MEUBLE DANS SON LOGEMENT, D'AERER FREQUEMMENT LA PIÈCE CONCERNÉE PENDANT AU MOINS QUATRE SEMAINES AFIN DE RÉDUIRE SON EXPOSITION AUX POLLUANTS ÉMIS PAR LE MEUBLE.

NE FORCEZ JAMAIS LES RACCORDS. RESSERREZ LES VIS APRES UN CERTAIN TEMPS D'UTILISATION. CONSERVEZ LA NOTICE DE MONTAGE. EN CAS DE PIECE MANQUANTE, CE SERA LE MEILLEUR MOYEN D'EN INFORMER LE MAGASIN.

N'UTILISEZ JAMAIS DES PRODUITS ABRASIFS COMME DE LA LAINE D'ACIER, DU PAPIER DE VERRE, DES SOLVANTS, ETC. NE MOUILLEZ PAS LE MEUBLE ET EVITEZ TOUTE ESPOSITION A UNE HUMIDITE IMPORTANTE.

ENGLISH

ASSEMBLY ADVICE:
 1- STUDY THE ASSEMBLY MANUAL CAREFULLY.
 2- LOCATE THE PARTS THAT COMPRISE YOUR FURNITURE ITEM.
 3- ORGANISE AND CHECK THE FITTINGS SUPPLIED.
 4- HAVE THE NECESSARY TOOLS TO HAND.
 5- PREPARE AN ASSEMBLY AREA.
MAINTENANCE ADVICE:
 1- REMOVE DUST CAREFULLY.
 2- MOISTEN A SOFT, CLEAN CLOTH WITH SLIGHTLY SOAPY WATER.

DO NOT FORCE ANY OF THE JOINTS. TIGHTEN THE SCREWS AFTER HAVING USED THE FURNITURE FOR SOME TIME. KEEP YOUR ASSEMBLY MANUAL. IF ANY PART IS MISSING, IT WILL HELP YOU TO LET THE SHOP KNOW.

NEVER USE ABRASIVE PRODUCTS SUCH AS STEEL WOOL, SANDPAPER, ETC. DO NOT WET THE FURNITURE OR KEEP IT IN A VERY DAMP PLACE.

DEUTSCH

HINWEISE ZUR MONTAGE:
 1- LESEN SIE AUFMERKSAM DIE MONTAGEANLEITUNG DURCH.
 2- LOKALISIEREN SIE DIE ZUM MÖBEL GEHÖRENDE TEILE.
 3- KONTROLLIEREN SIE DIE MITGELIEFERTEN WERKZEUGE.
 4- RÜSTEN SIE SICH MIT DEN ZUSÄTZLICH BENÖTIGTEN WERKZEUGEN AUS.
 5- BEREITEN SIE EINEN PLATZ FÜR DIE MONTAGE VOR.
HINWEISE ZUR PFLEGE:
 1- ENTFERNEN SIE UMSICHTIG DEN ANGESAMMELTEN STAUB.
 2- VERWENDEN SIE EIN WEICHES UND SAUBERES TUCH UND SCHWACHE SEIFENLAUGE.

FORCIEREN SIE NIEMALS DIE VERBINDUNGEN. ZIEHEN SIE DIE SCHRAUBEN NACH EINER BESTIMMTEN NUTZUNGSZEIT NACH. BEWAHREN SIE DIE MONTAGEANLEITUNG AUF. SOLLTE EIN TEIL FEHLEN IST SIE VON GROSSER WICHTIGKEIT BEI DER NACHBESTELLUNG IM LADEN.

VERWENDEN SIE NIEMALS SCHEUERENDE PRODUKTE WIE STAHLWOLLE, SCHMIRGELPAPIER, LÖSUNGSMITTEL UND DERGL. WASSER UND HOHE FEUCHTIGKEIT SIND SCHÄDLICH FÜR DAS MÖBEL

POTUGUES

CONSELHO PARA A MONTAGEM :
 1 - ESTUDE ATENTAMENTE O MANUAL DE MONTAGEM.
 2 - LOCALIZE AS PEÇAS QUE CONSTITUEM O SEU MÓVEL.
 3 - REUNA E CONTROLE AS FERRAGENS FORNECIDAS.
 4 - EQUIPE-SE COM AS FERRAMENTAS NECESSÁRIAS.
 5 - PREPARE UMA ZONA DE MONTAGEM.
CONSELHOS PARA A MANUTENÇÃO :
 1- RETIRAR A POEIRA COM CUIDADO.
 2 - HUMEDECER UM PANO SUAVE E LIMPO COM ÁGUA LIGEIRAMENTE ENSABOADA.

NUNCA FORCE AS UNIÕES. APORTE OS PARAFUSOS DEPOIS DE DETERMINADO TEMPO DE UTILIZAÇÃO.. CONSERVE O SEU MANUAL DE MONTAGEM, SE FALTAR UMA PEÇA SERIA A MANEIRA MAIS FÁCIL DE A COMUNICAR À LOJA.

NUNCA USE PRODUTOS ABRASIVOS TAIS COMO : LÃ DE AÇO, LIXAS, DISSOLVENTS, ETC.. NÃO MOLAR NEM SUBMETTER A GRANDES HUMIDADES, O MÓVEL.

ITALIANO

CONSIGLI PER IL MONTAGGIO:
 1- STUDIARE ATTENTAMENTE IL MANUALE DI MONTAGGIO.
 2- INDIVIDUARE LE PARTI CHE COSTITUISCONO IL MOBILE.
 3- RACCOGLIERE E CONTROLLARE GLI ATTREZZI IN DOTAZIONE.
 4- PROCURARSI GLI ATTREZZI NECESSARI.
 5- PREPARARE UNA ZONA PER IL MONTAGGIO.
CONSIGLI PER LA MANUTENZIONE:
 1- SPOLVERARE ACCURATAMENTE.
 2- INUMIDIRE UN PANNINO MORBIDO E PULITO CON ACQUA E POCO DETERGENTE.

NON FORZARE MAI LE GIUNTURE. STRINGERE NUOVAMENTE LE VITI DOPO UN CERTO PERIODO D'USO. CONSERVARE IL MANUALE DI MONTAGGIO: SE MANCASSE UN PEZZO SAREBBE COSÌ PIÙ FACILE COMUNICARLO AL RIVENDITORE.

NON USARE MAI PRODOTTI ABRASIVI COME: SPUGNE ABRASIVE, CARTA VETRATA, SOLVENTI, ECC. NON BAGNARE NE' SOTTOPORRE IL MOBILE A FORTE UMIDITÀ.

SLOVENSKO

Upozornenie
Pozorne si prečítajte montážny návod
Pripravte si všetky montážne diely
Skontrolujte všetky diely a dodané súčiastky
Pripravte si potrebné nástroje
Pracujte na dostatočne veľkom priestore
Údržba
Opatrne očistite všetky montážne diely
Používajte mäkkú, čistú handričku a jemne mydlovú vodu

Nikdy nedotahujte skrutky príliš veľkou silou. Skrutky dotiahnite po krátkej dobe užívania. Uchovajte montážny návod. V prípade chýbajúceho dielu, uľahčí návod jeho identifikáciu.

Nikdy nepoužívajte abrazívne predmety ako brusný papier atď. Nenamáčajte nábytok ani ho nevystavujte nadmernej vlhkosti.

1/2

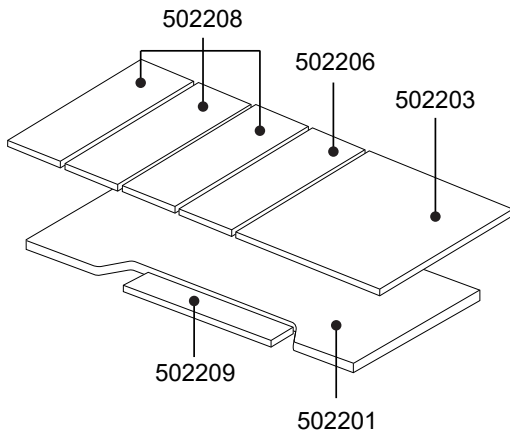

5022A

2/2



T1 T2
X AC1
AC2

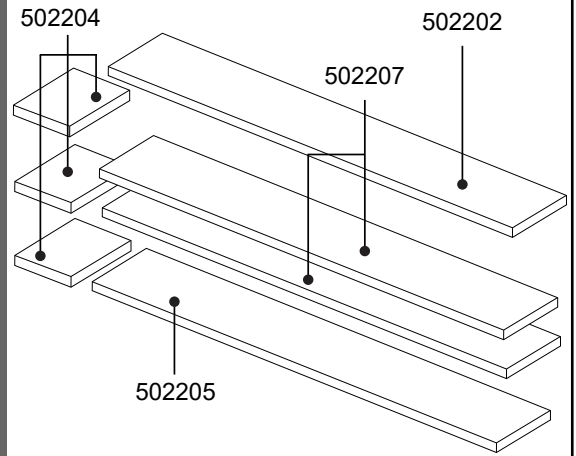

5022B

T1

x24

x24

x40

x21

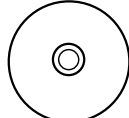
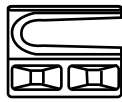
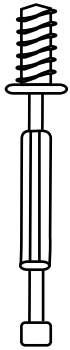

PE845

EX16

CL830

TE17AN

T2

x6

x3

x3

x14

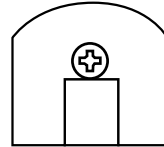
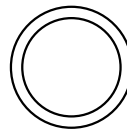
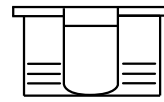
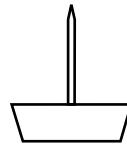

TSM

SKM16

TCK0311

T8AN

T3

x5

x10

x2

x4

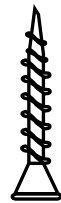

TP3515

T5AN

TP3540

TP3525

X



x2

x1

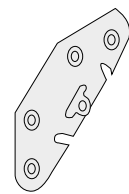
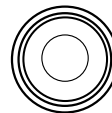
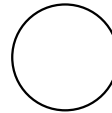

TEMB18C

ECG

x1

x1

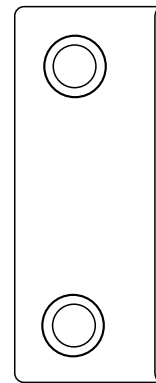

EA2020

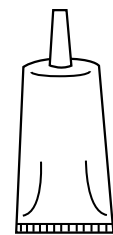

LEPIDLO

AC1

x1

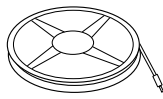

TL200

AC2

x1

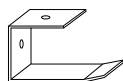

SAG

1

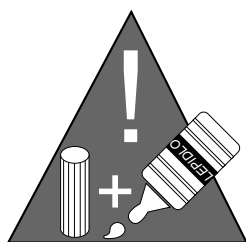
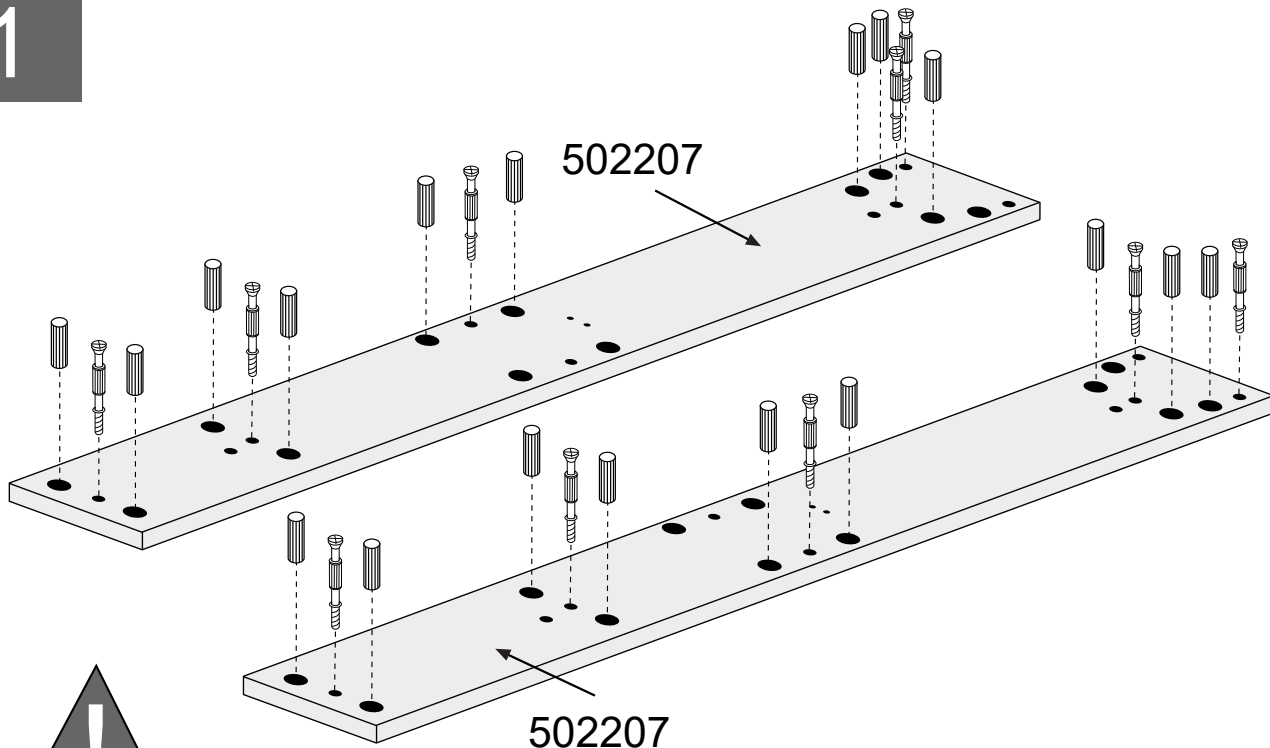

cm 0 1 2 3 4 5

PE845  x10

CL830  x18

2

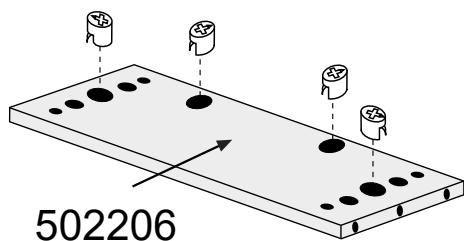

502206

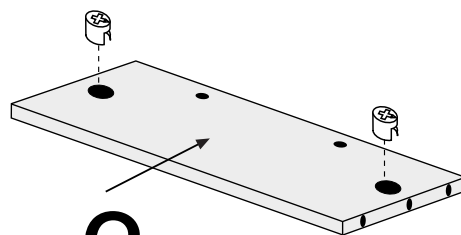

x3
502208

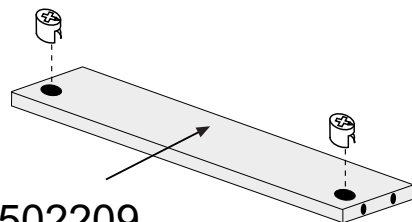

502209

cm 0 1 2

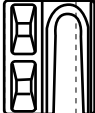
EX16   x12

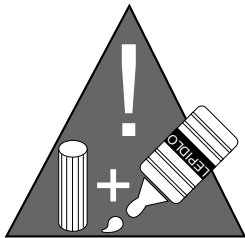
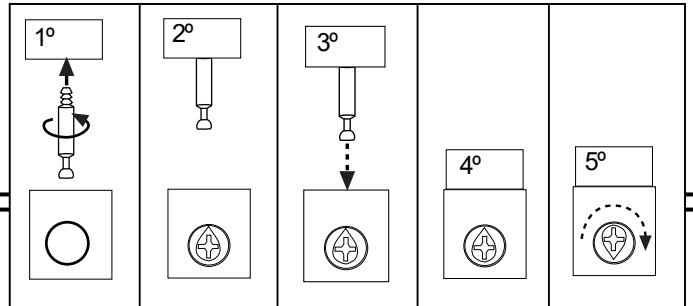
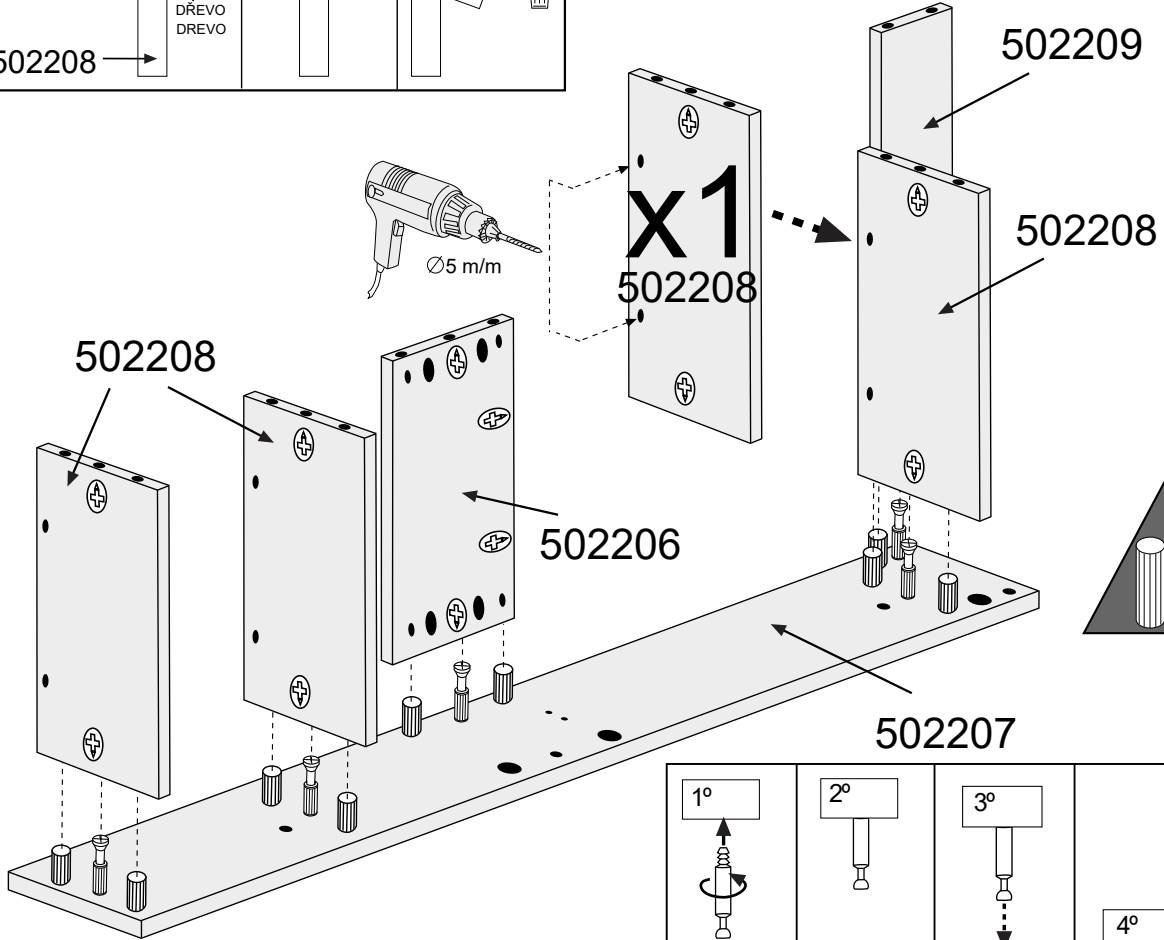
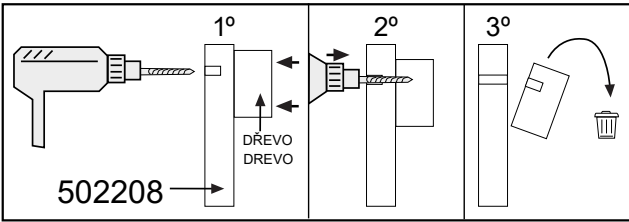

502207

x4



TSM

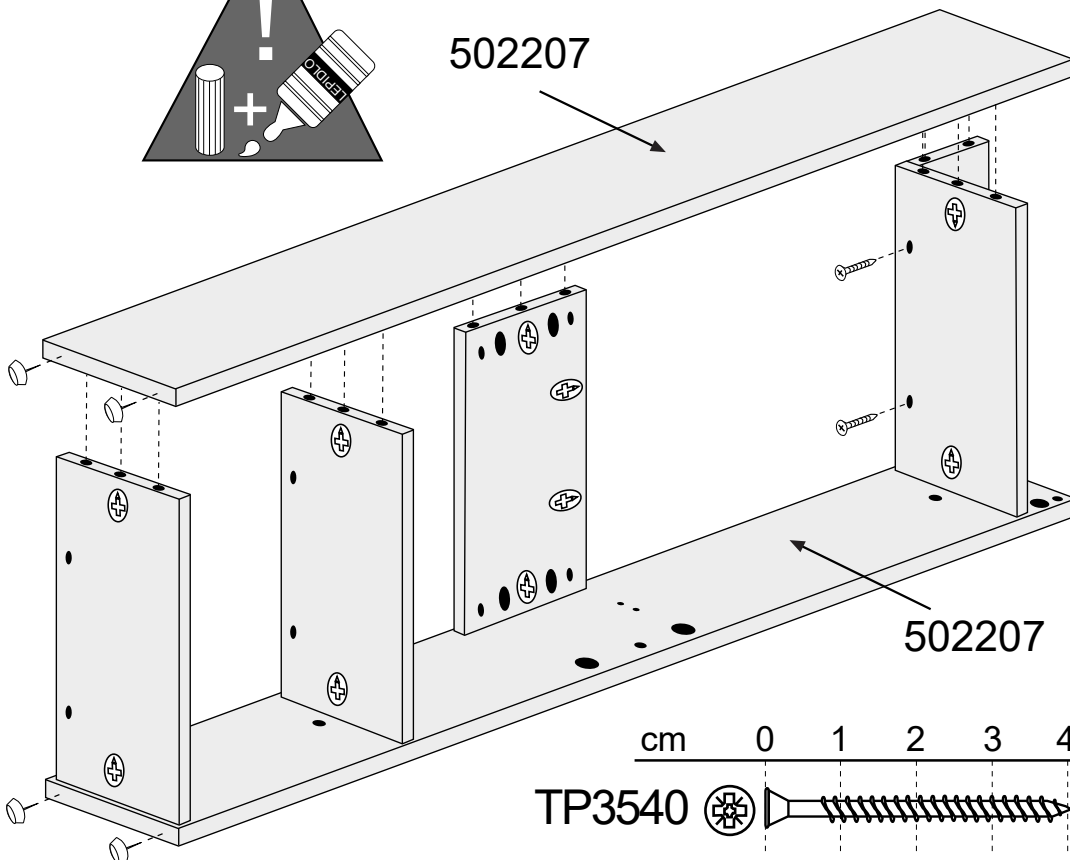

5

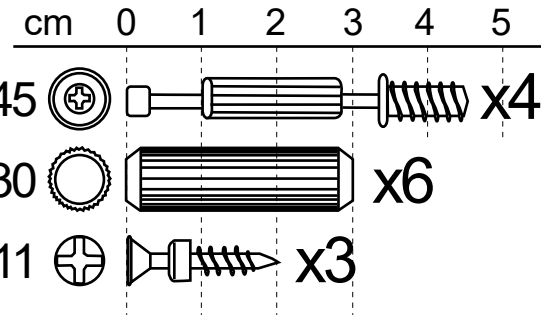
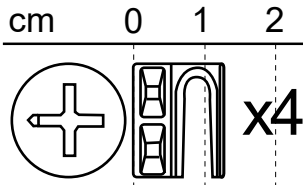
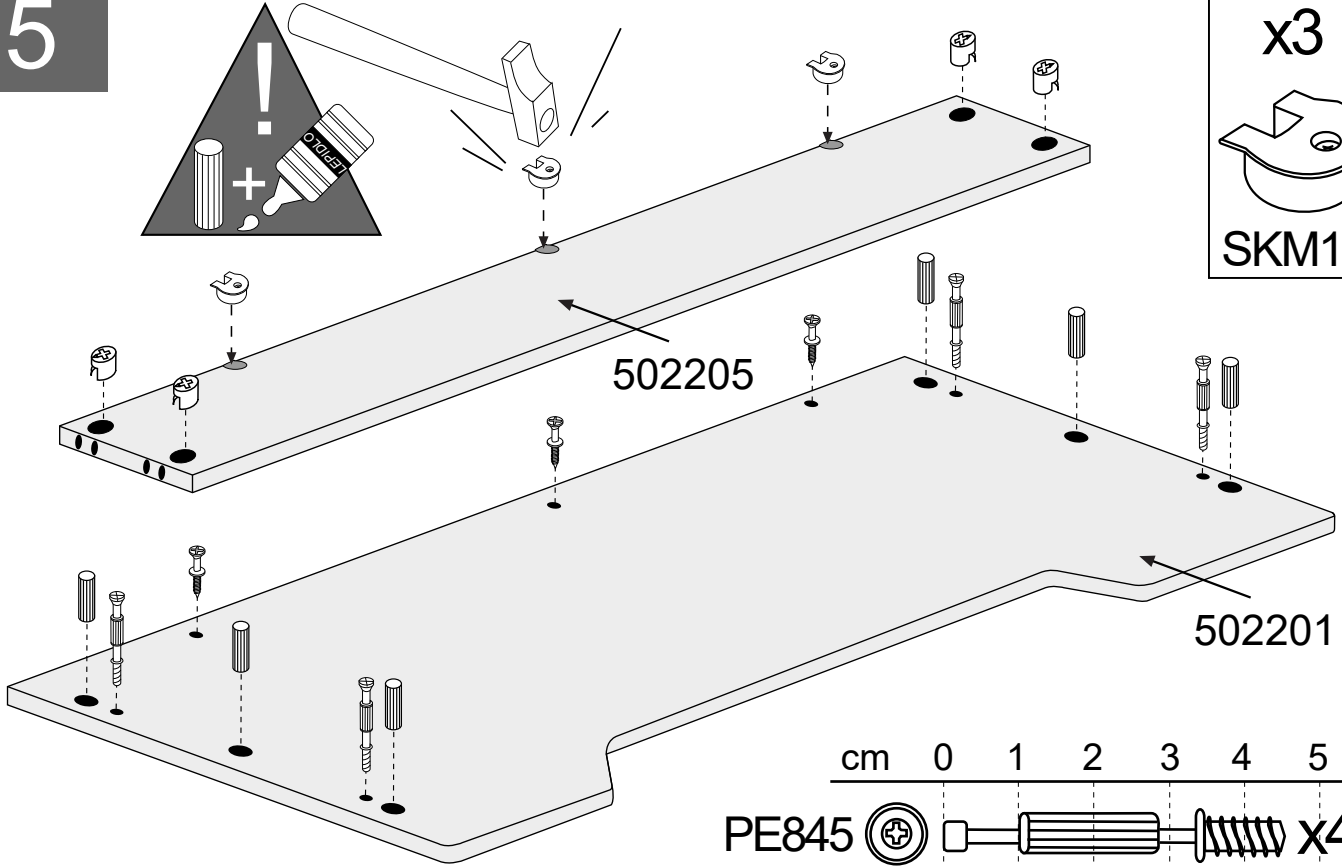
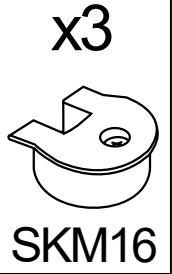
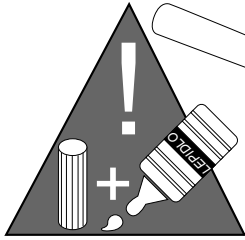

EX16

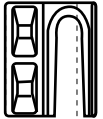
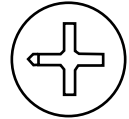

x4

PE845



x4

CL830



x6

TCK0311



x3

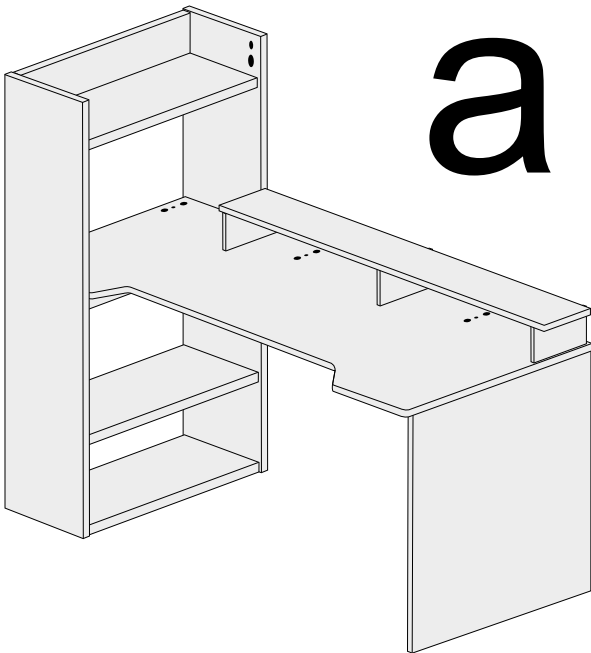

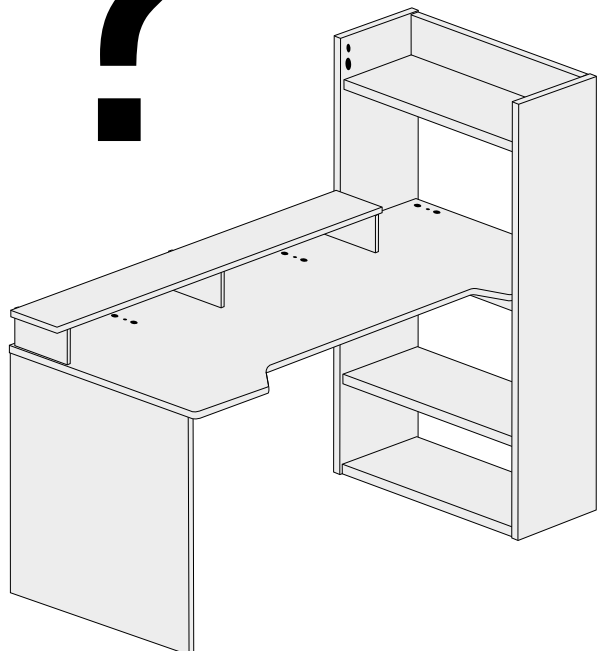
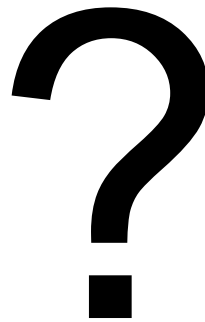

a



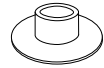

b

6a

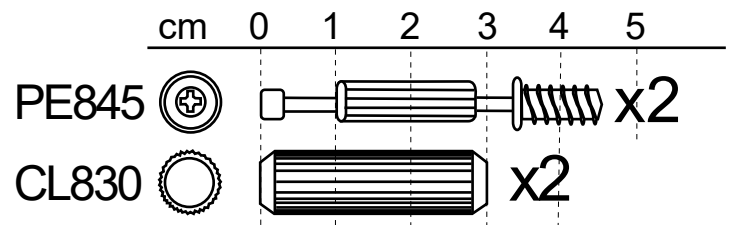
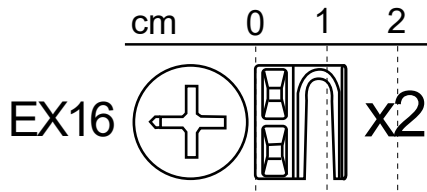
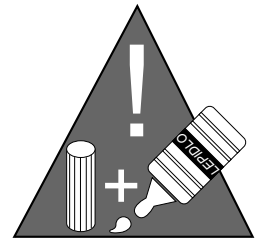
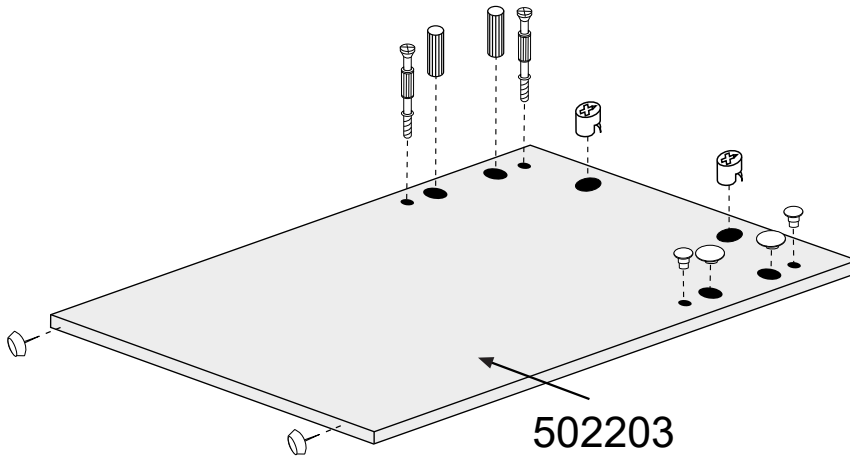
x2	x2	x2
		
T5AN	T8AN	TSM



7a

x5	x5	x6
		
TE17AN	T5AN	T8AN

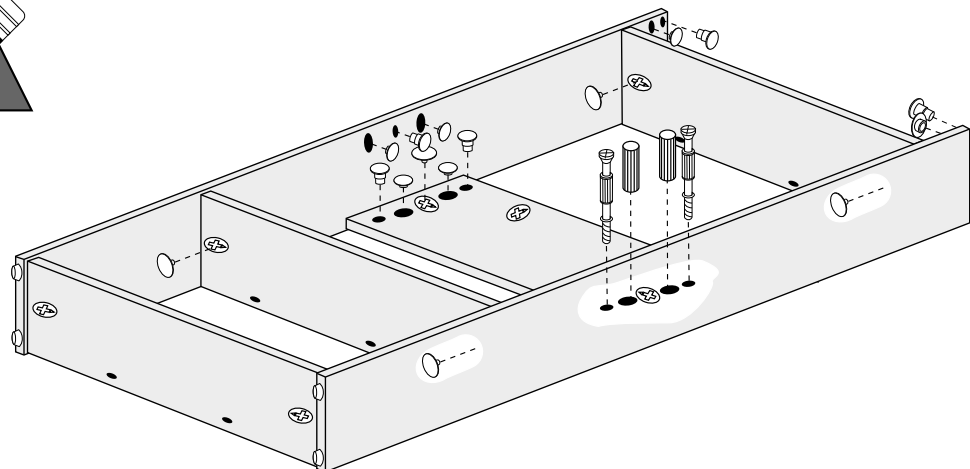
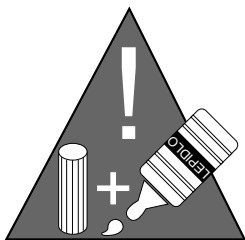
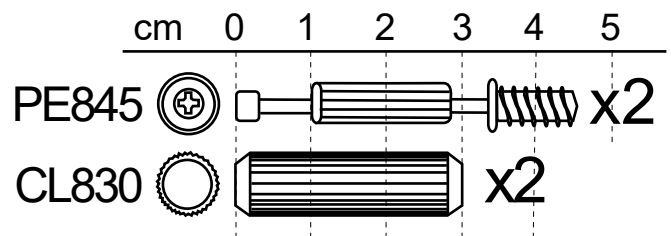





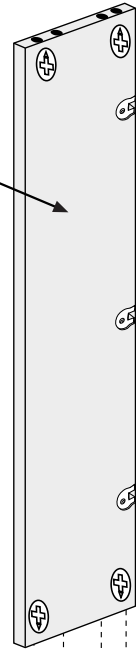

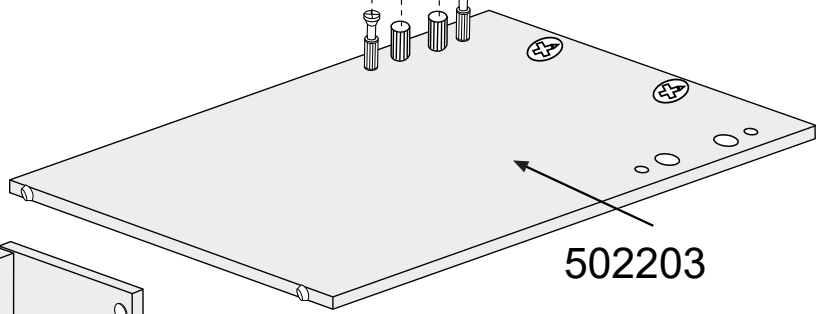

8a

502205



502203



1° 	2° 
	
3° 	
	4° 
5° 	

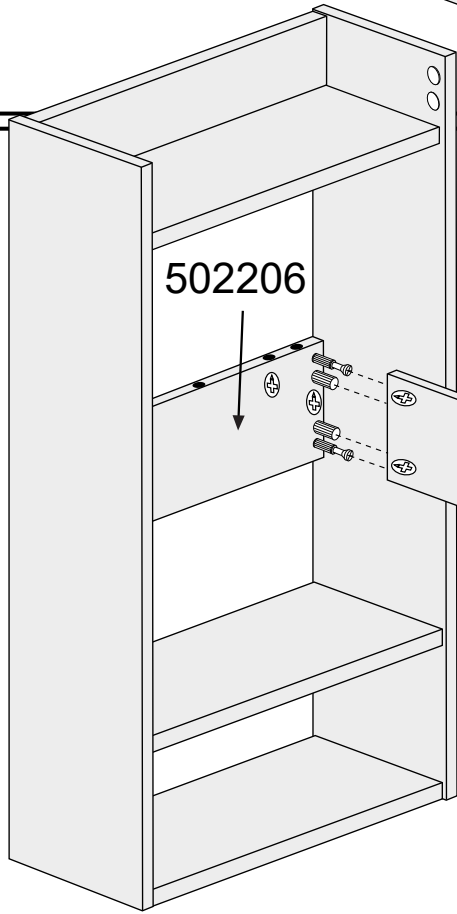

502206

502205

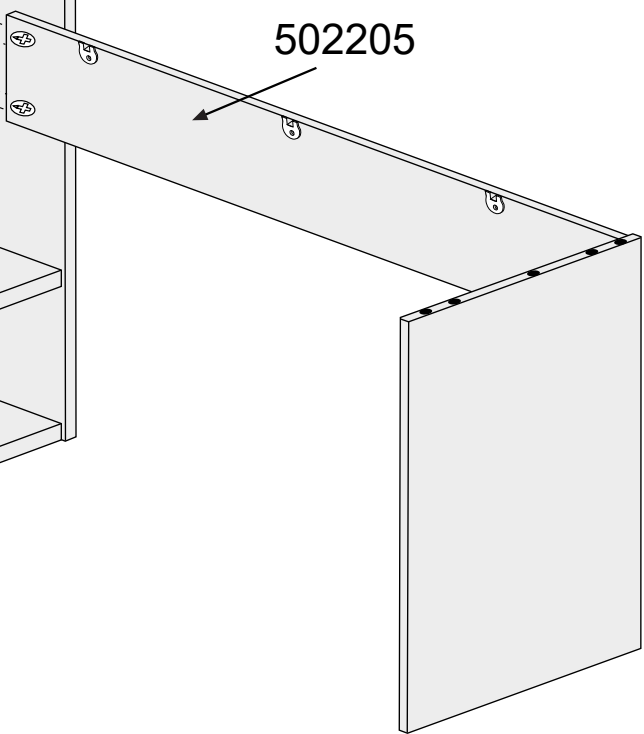

9a

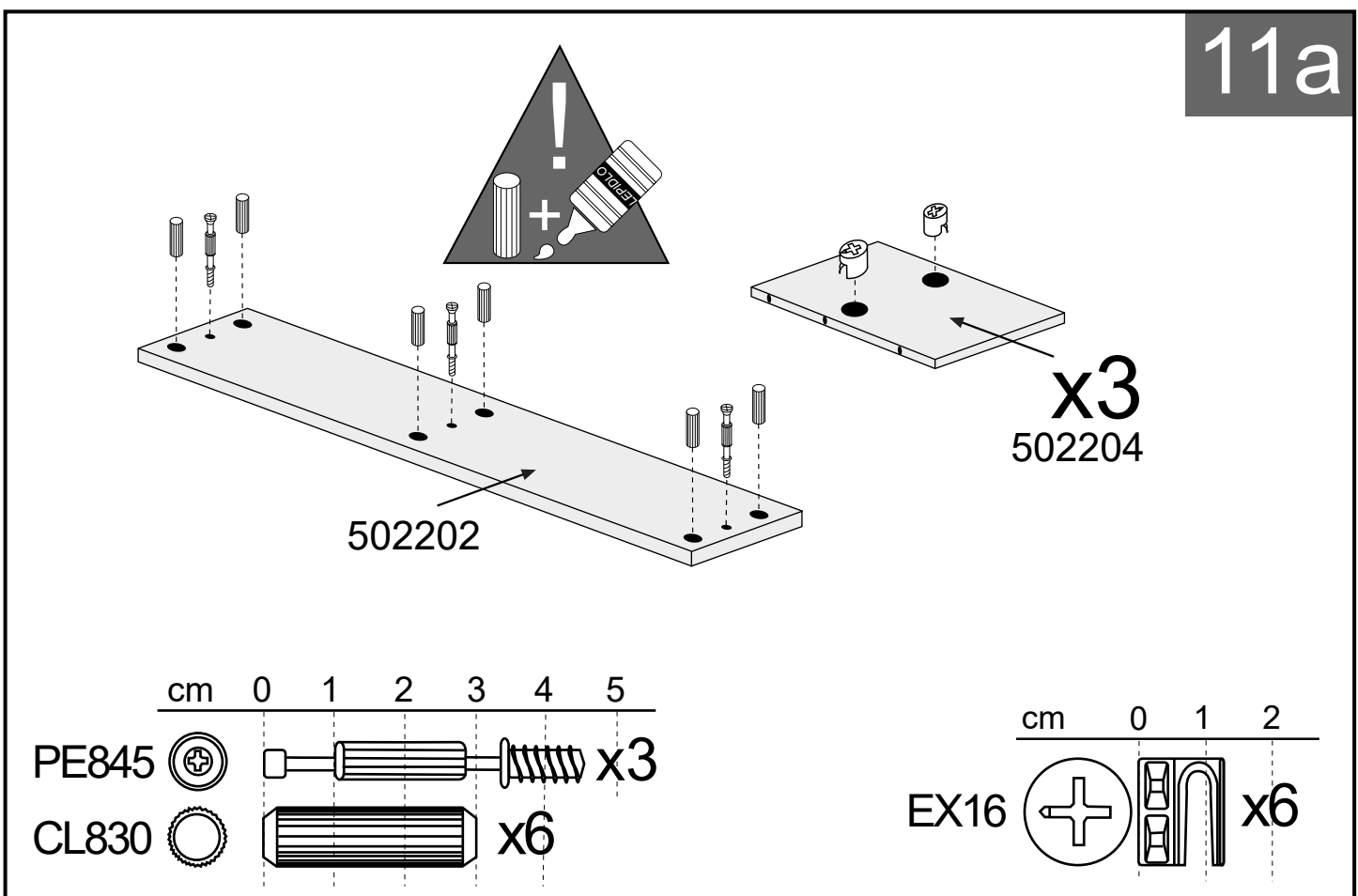
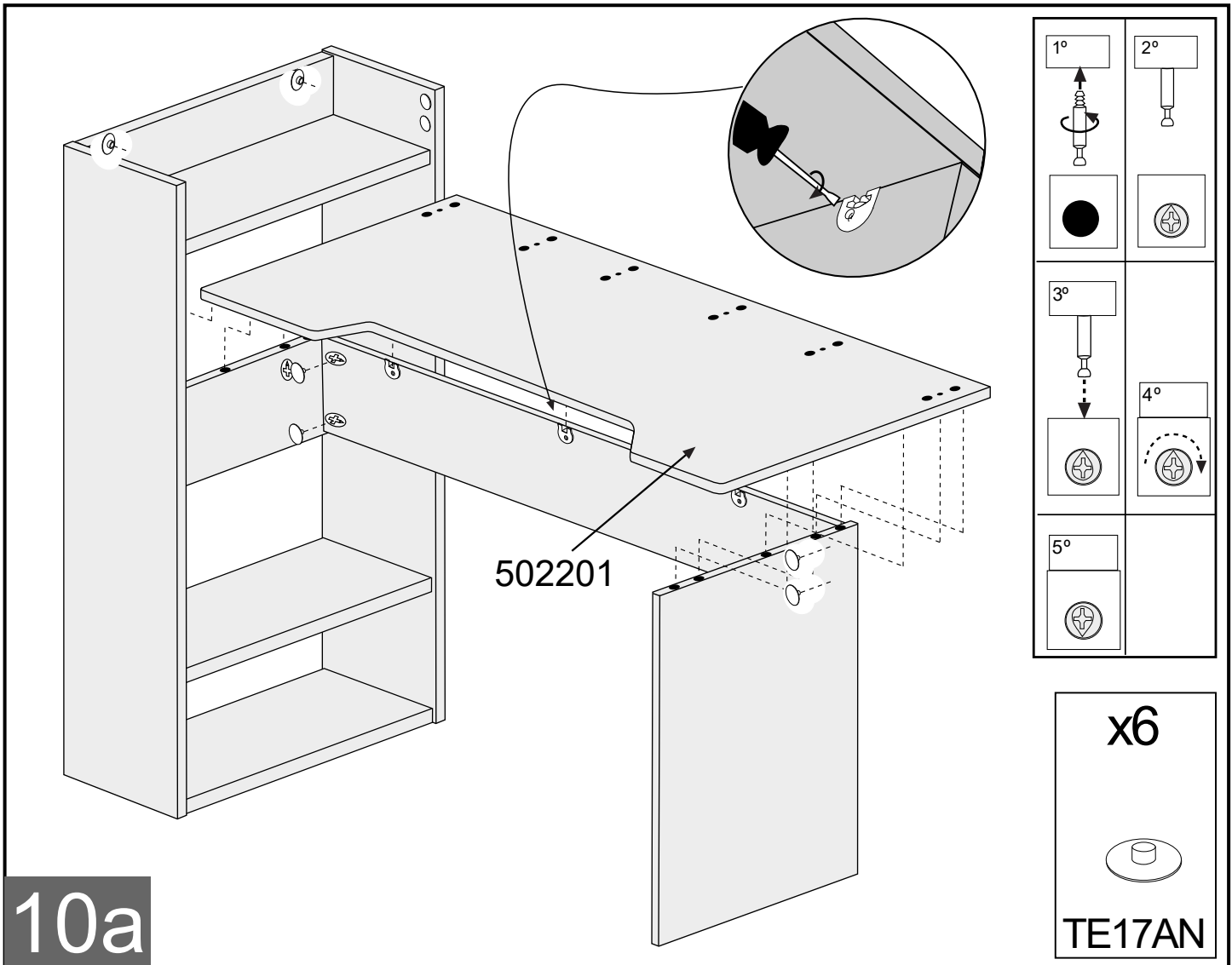

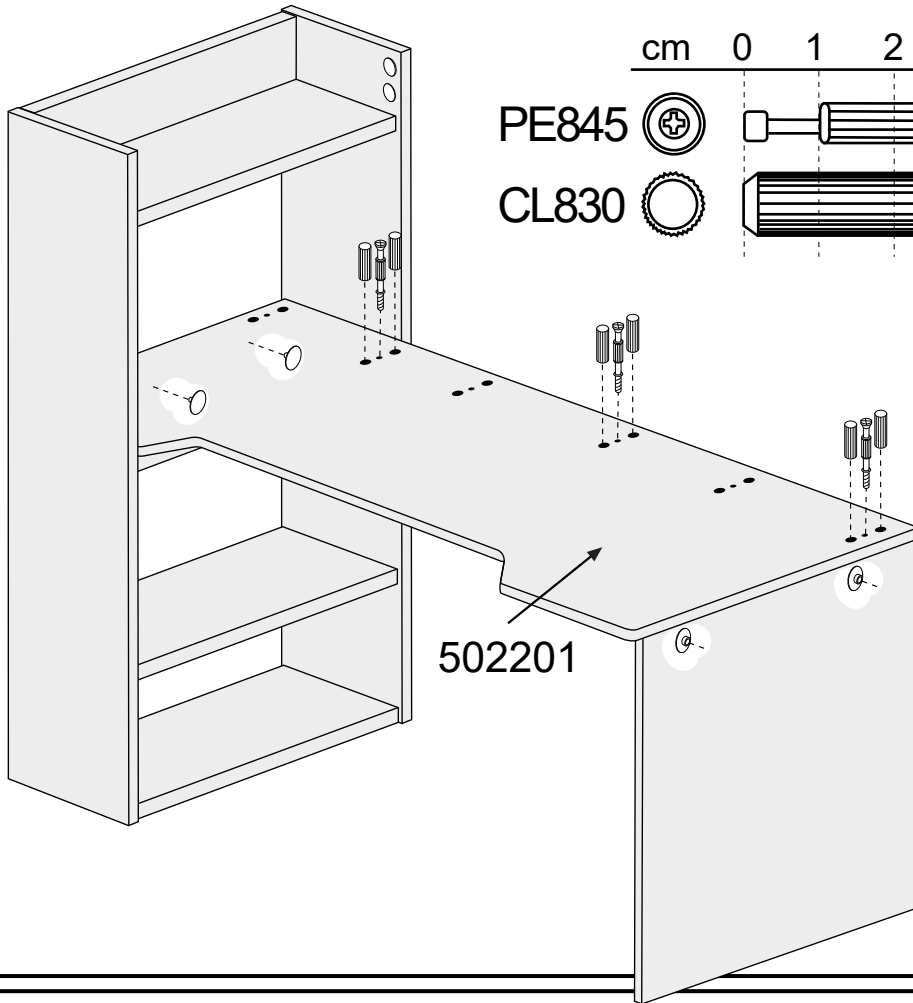

12a

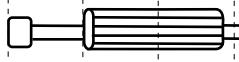

cm 0 1 2 3 4 5

PE845   x3



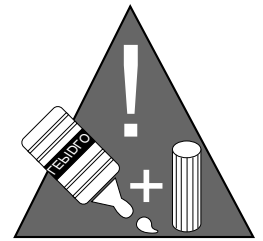



CL830   x6

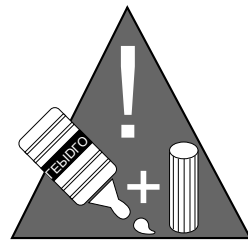
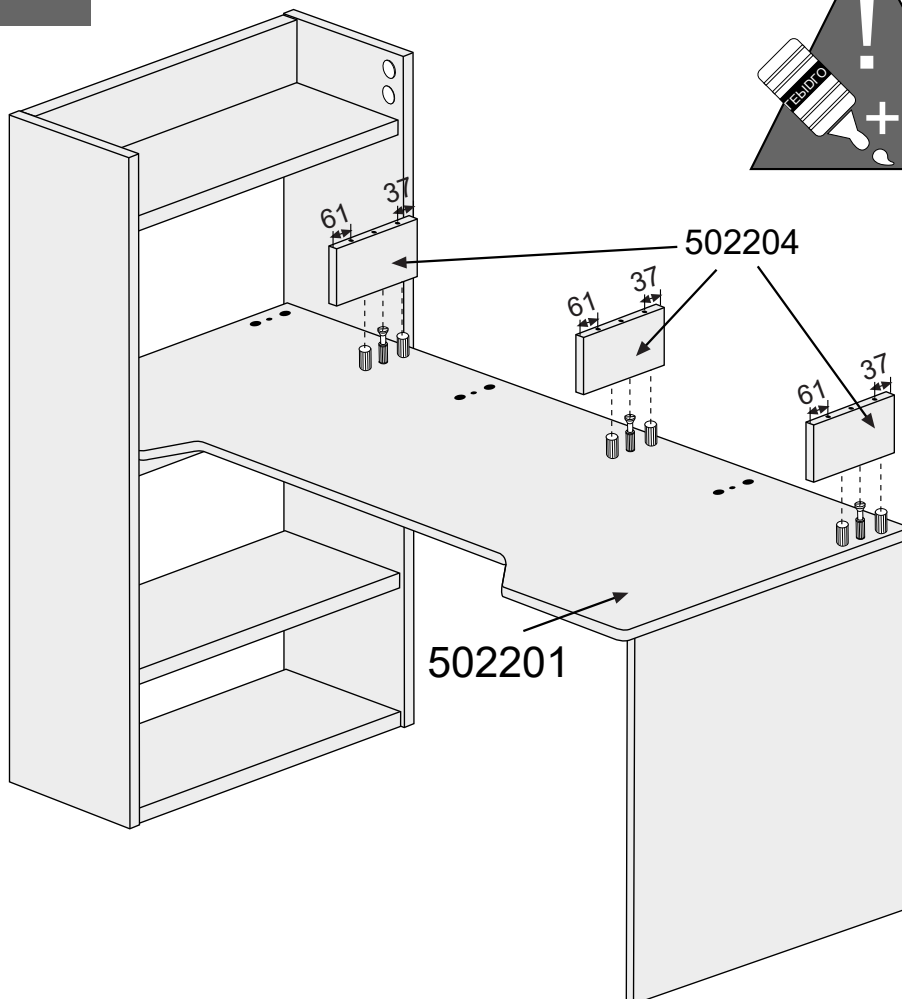

x4

TE17AN

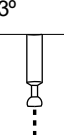
13a

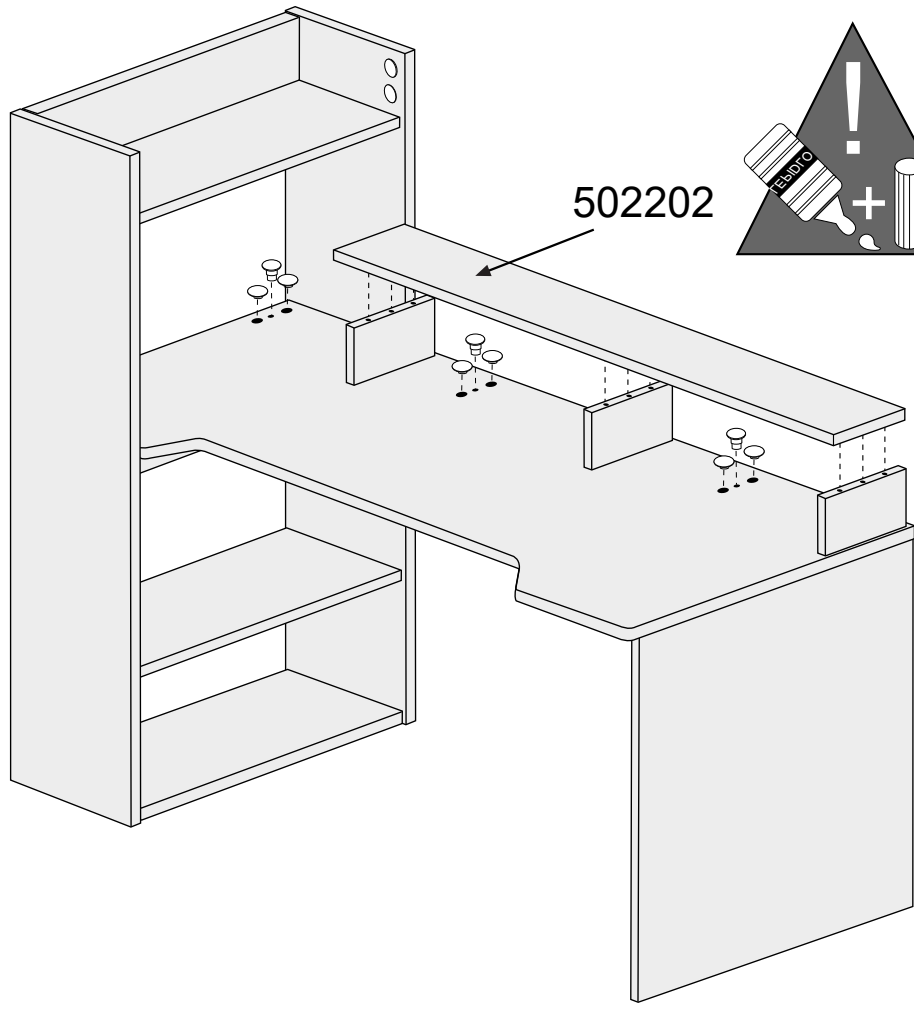

1° 	2° 
	
3° 	4° 
5° 	

14a



- x6
-
- T8AN
- x3
-
- T5AN

- | | |
|--------|--------|
| 1°
 | 2°
 |
| 3°
 | 4°
 |
| 5°
 | |

15a

cm 0 1 2
TP3515 x1

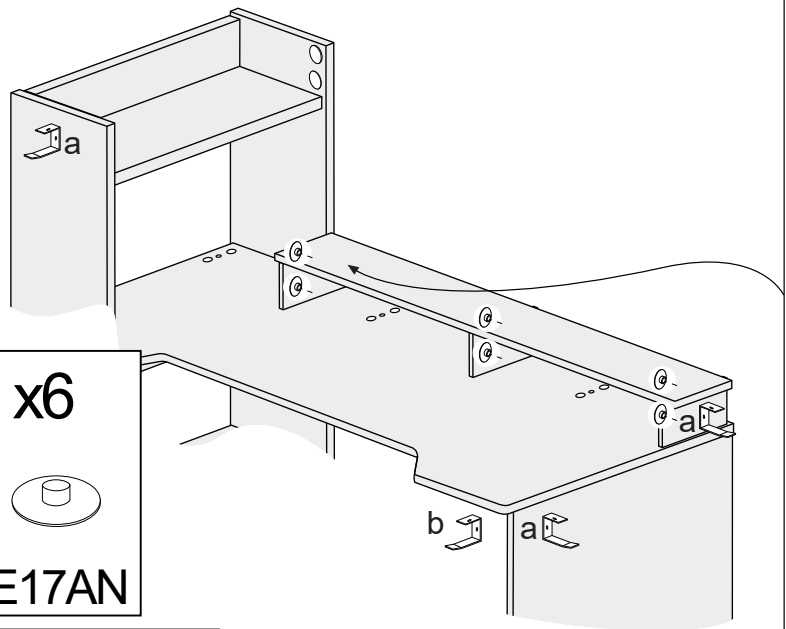

- x6
-
- TE17AN

- x1
-
- TL200

- x1
-
- SAG

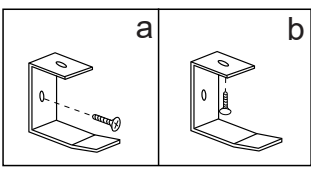

- 1
- 2
- 3
- 4
- 5

Zdroj napájení USB 5V
Kábel není součástí balení
Minimum 1A

Zdroj napájania USB 5V
Kábel nie je súčasťou balenia
Minimum 1A

16a

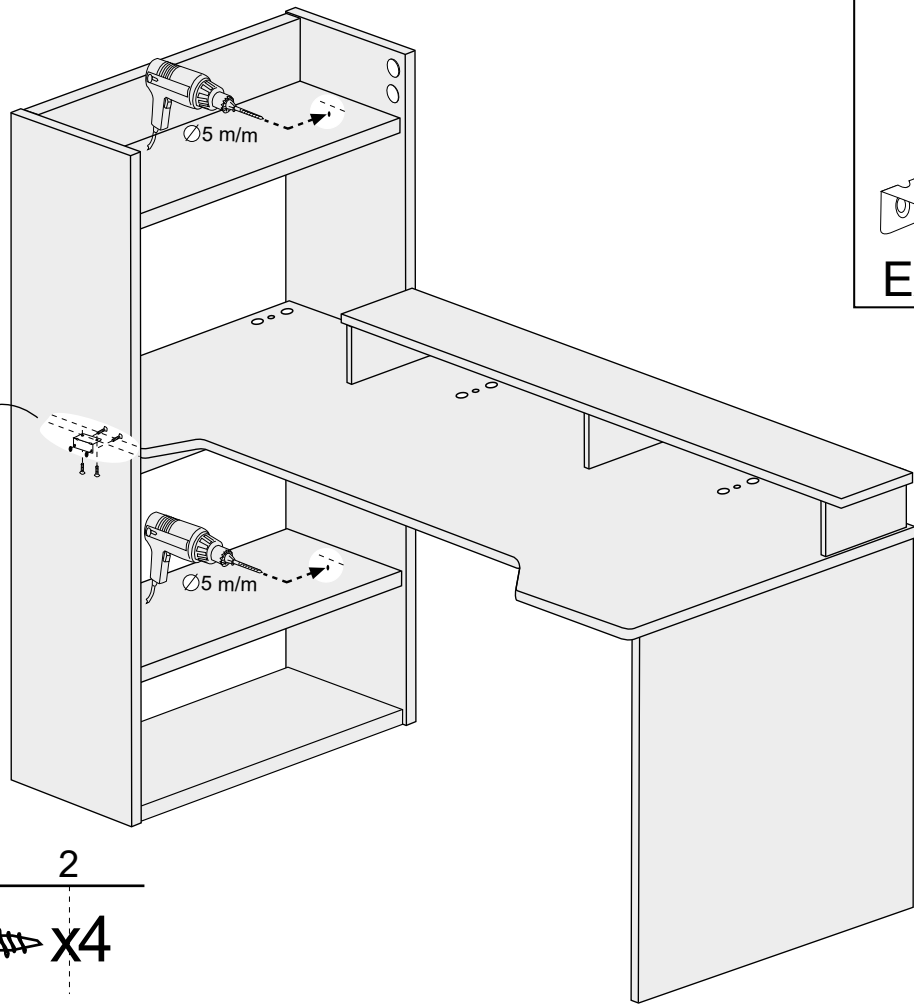

x1

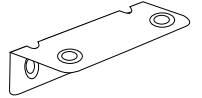

EA2020

TP3515

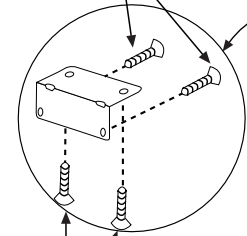

TP3515

cm 0 1 2

TP3515  x4

17a

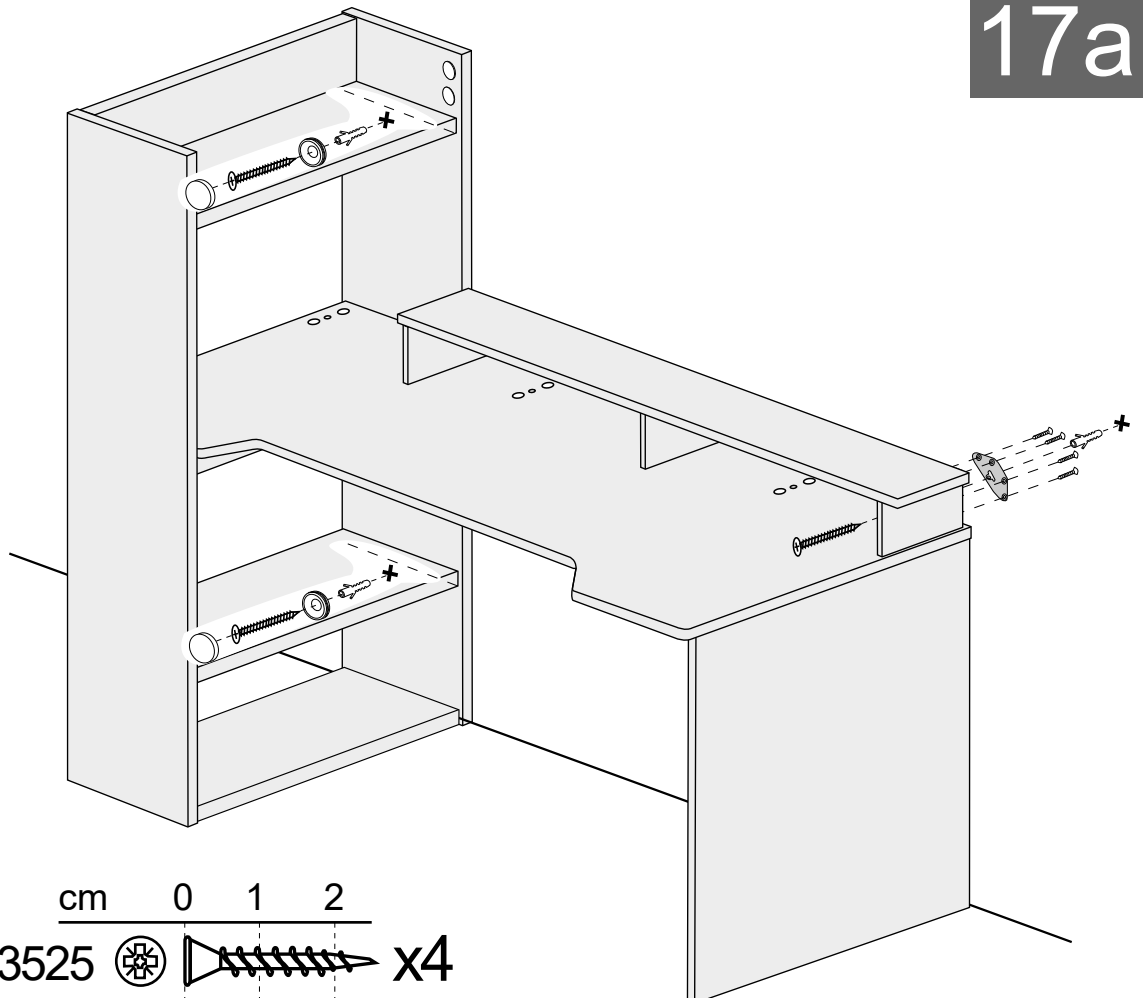

x1

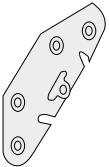

ECG

x2

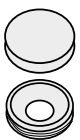

TEMB18C

cm 0 1 2

TP3525  x4

6b

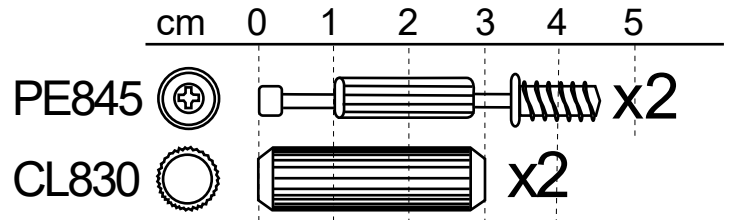
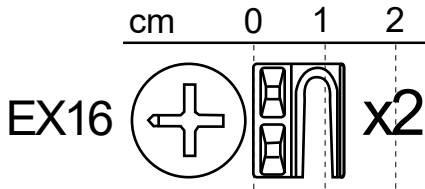
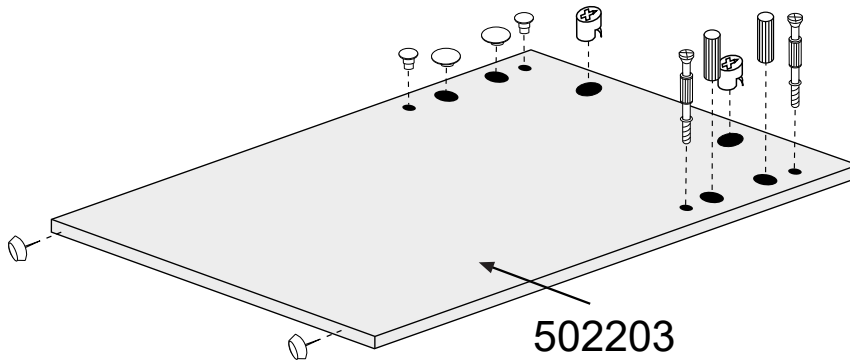
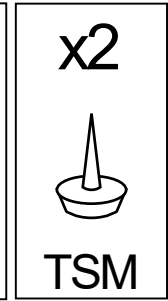
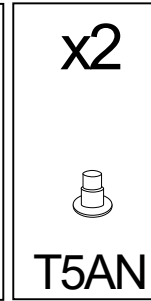
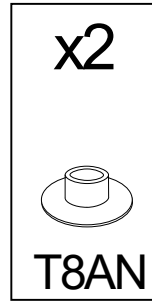
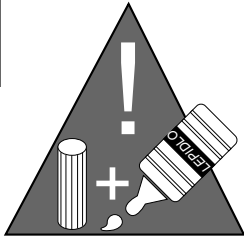

7b

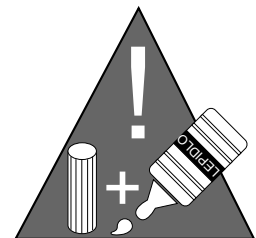
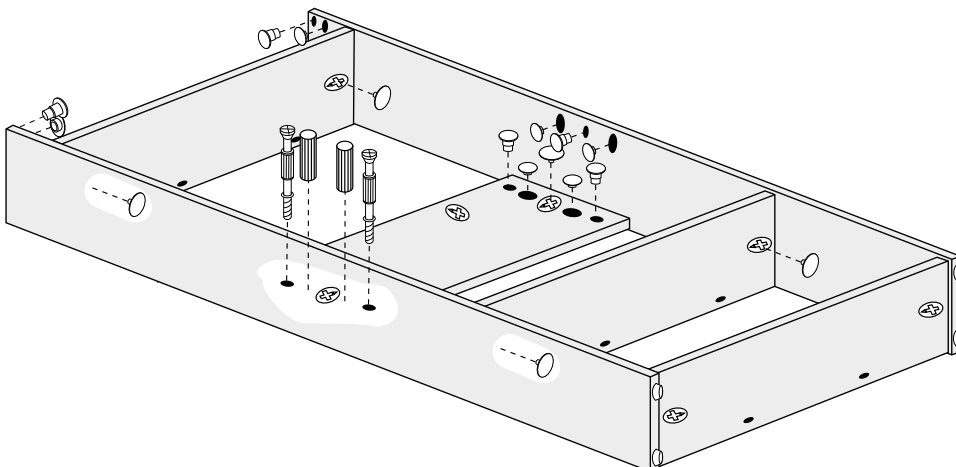
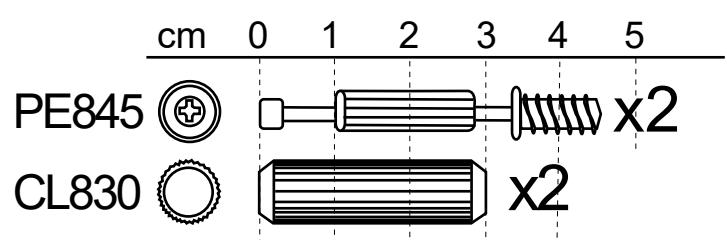
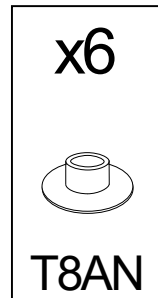
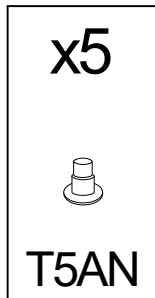
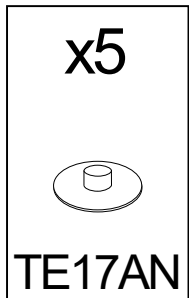

8b

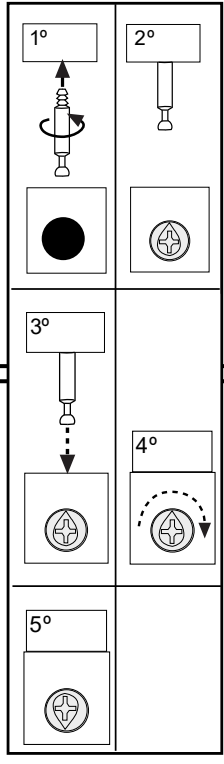
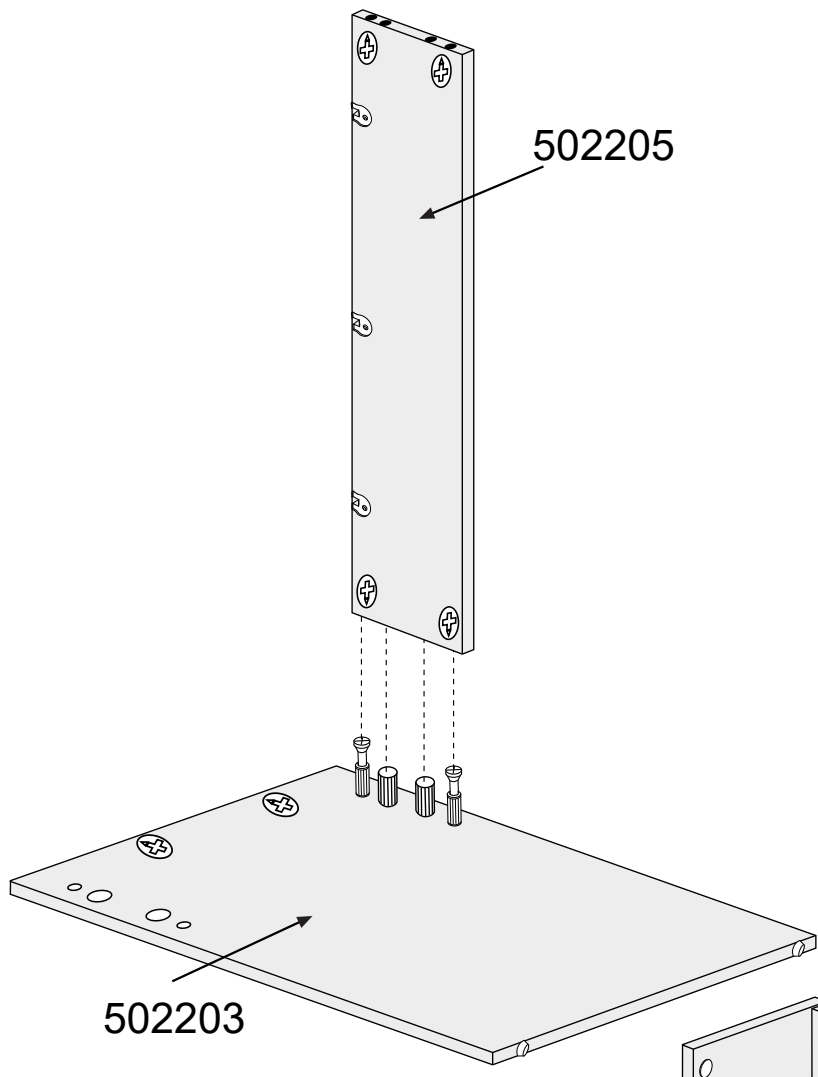

9b

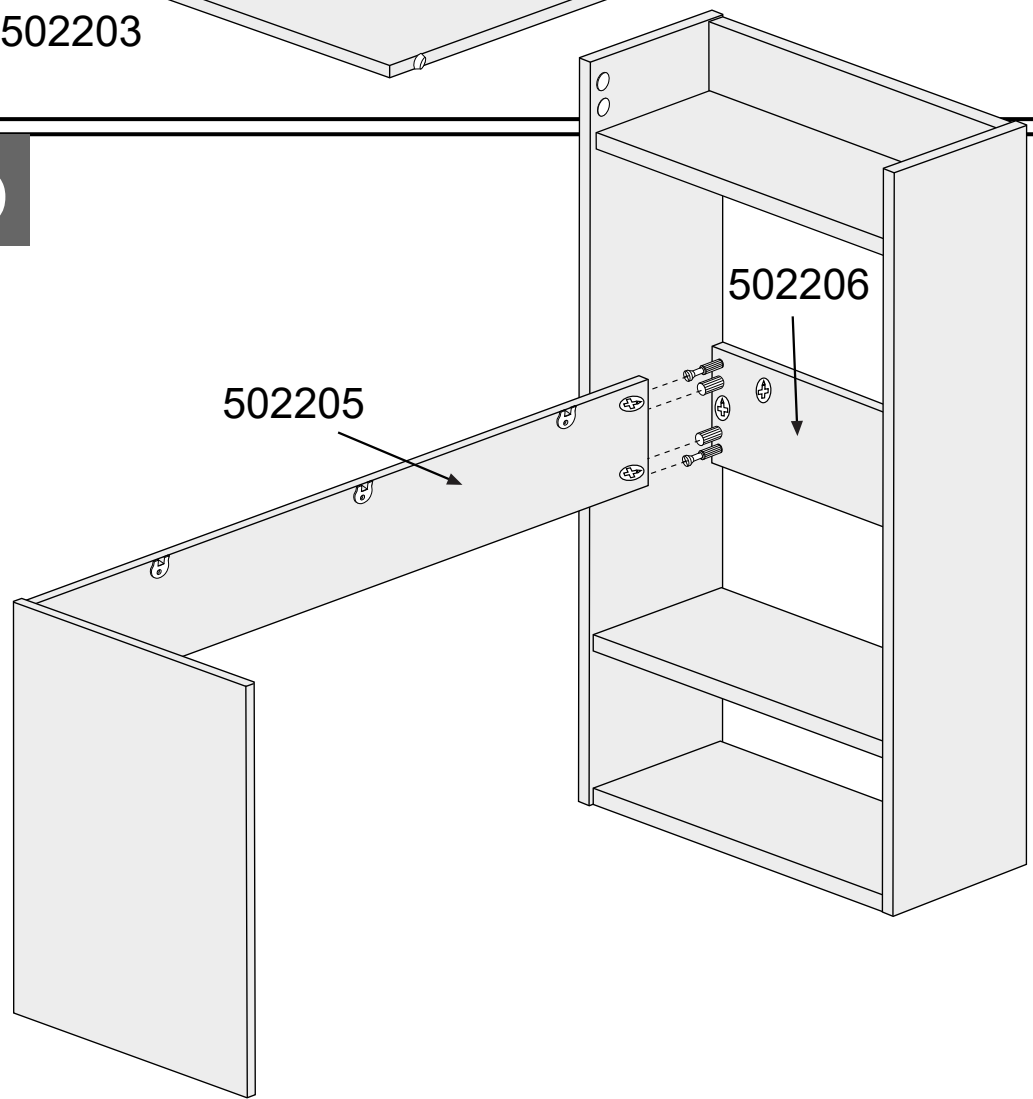

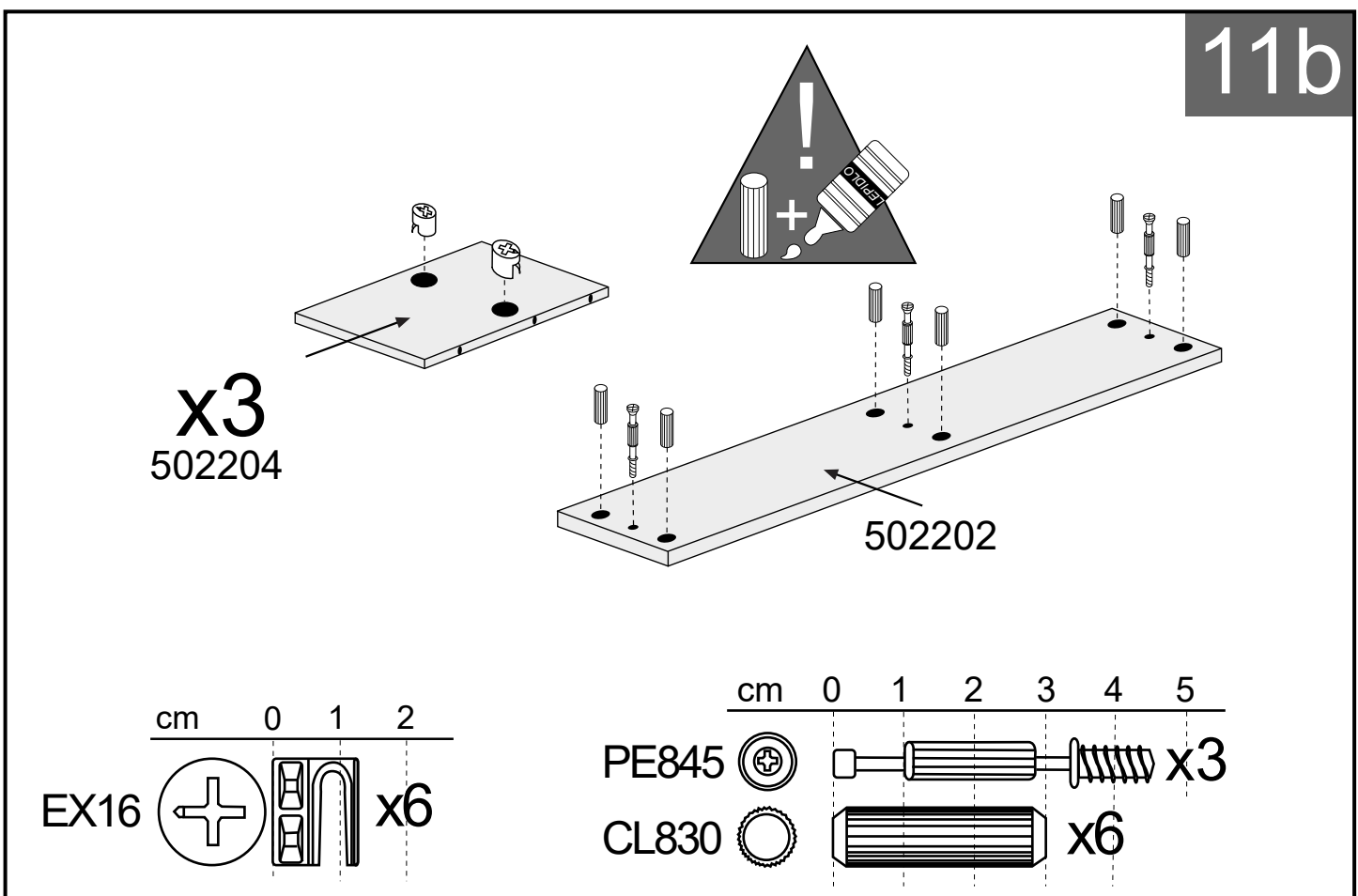
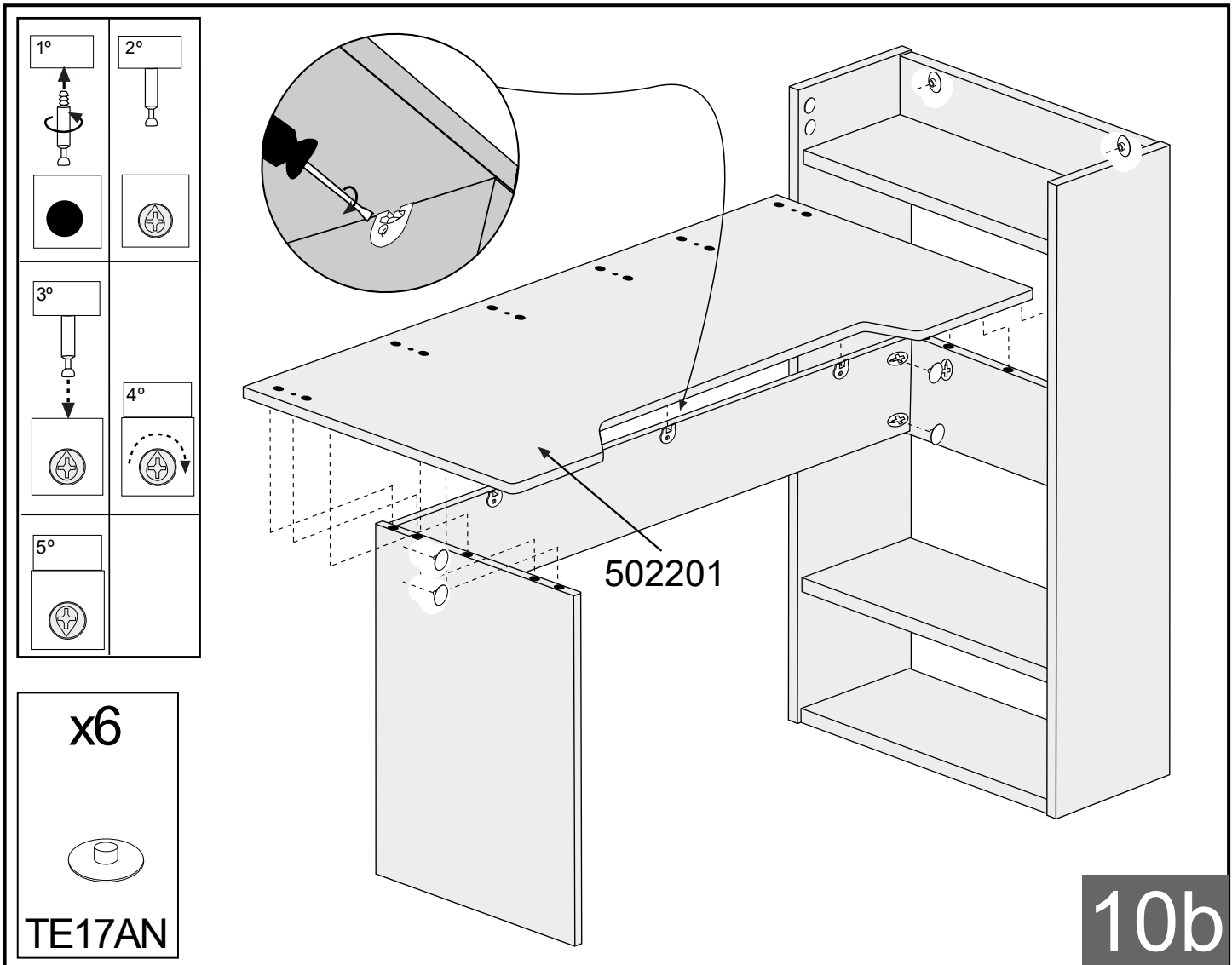

12b

cm 0 1 2 3 4 5

PE845  x3

CL830  x6

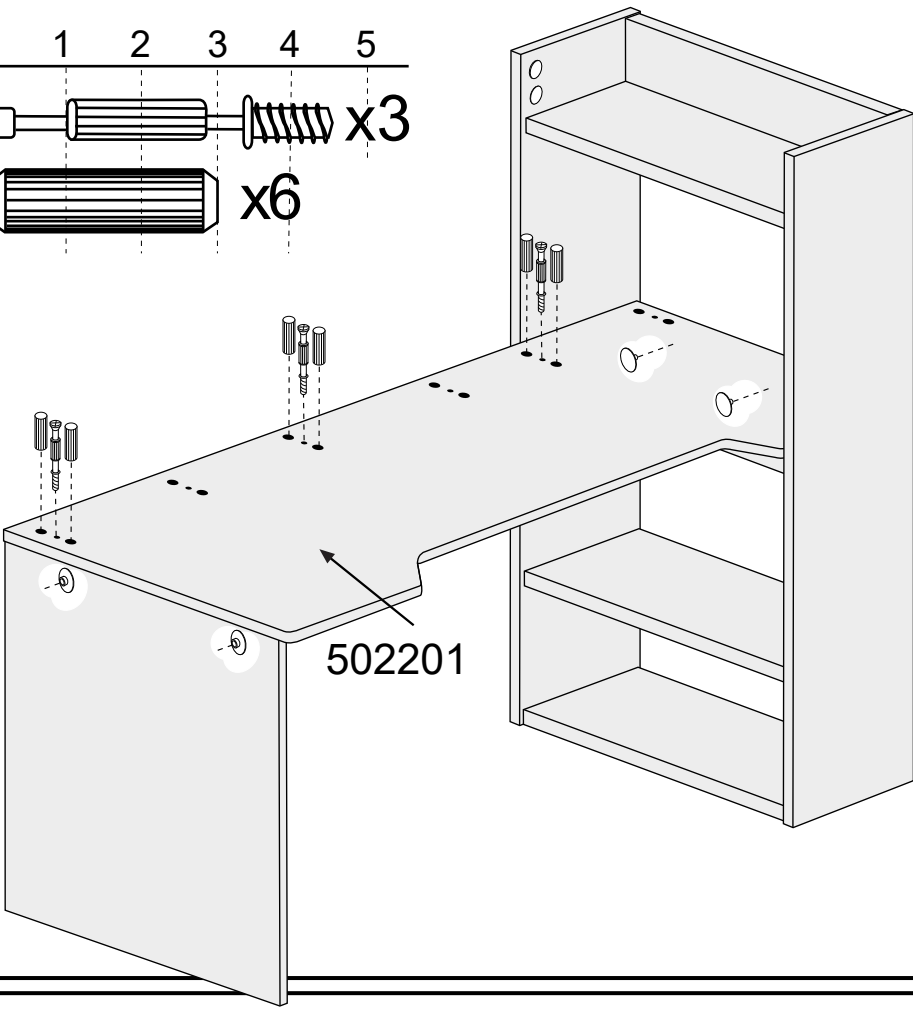
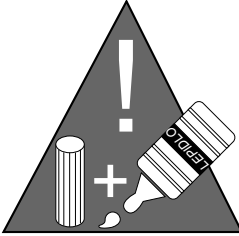



502201

x4

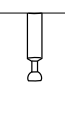

TE17AN

13b

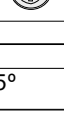
1° 	2° 
3° 	4° 
5° 	

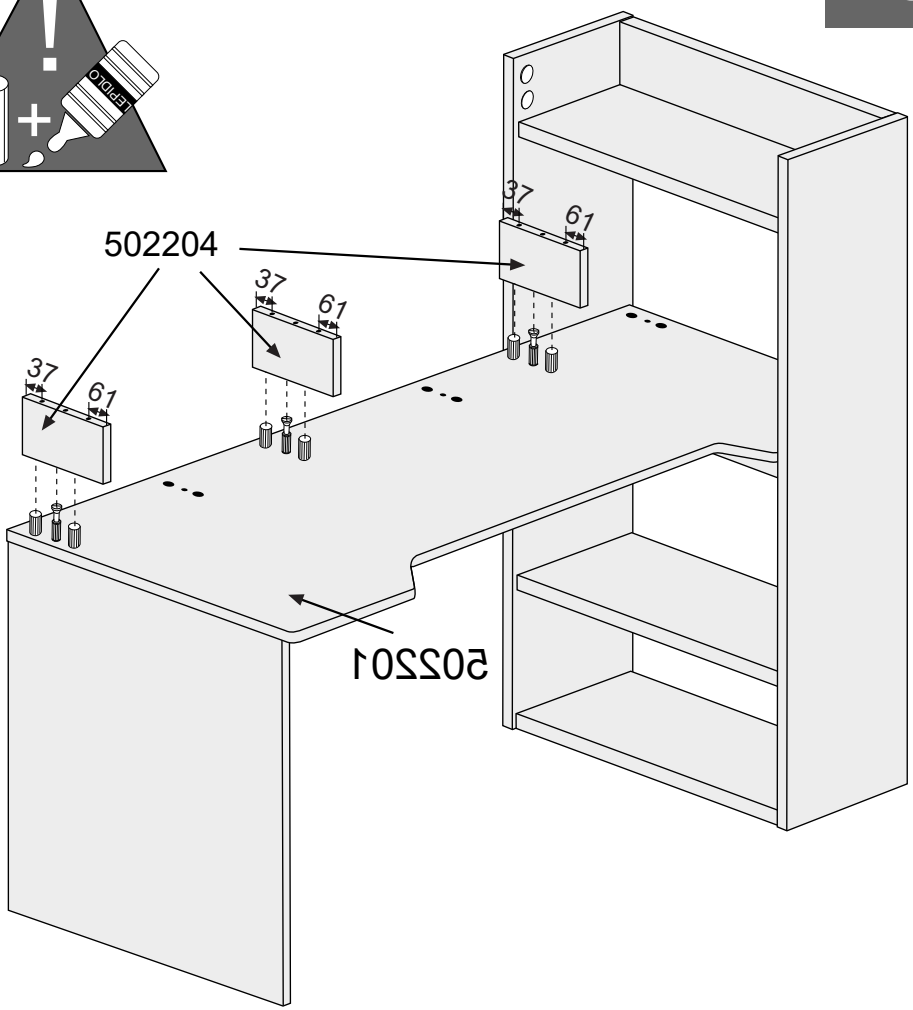
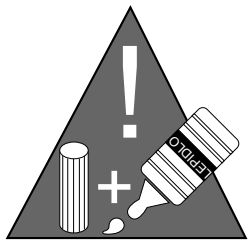

502204

37 61

37 61

502204

14b

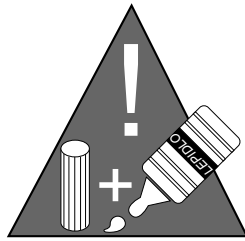

502202

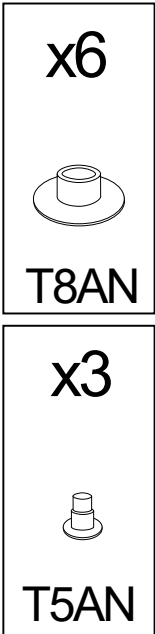
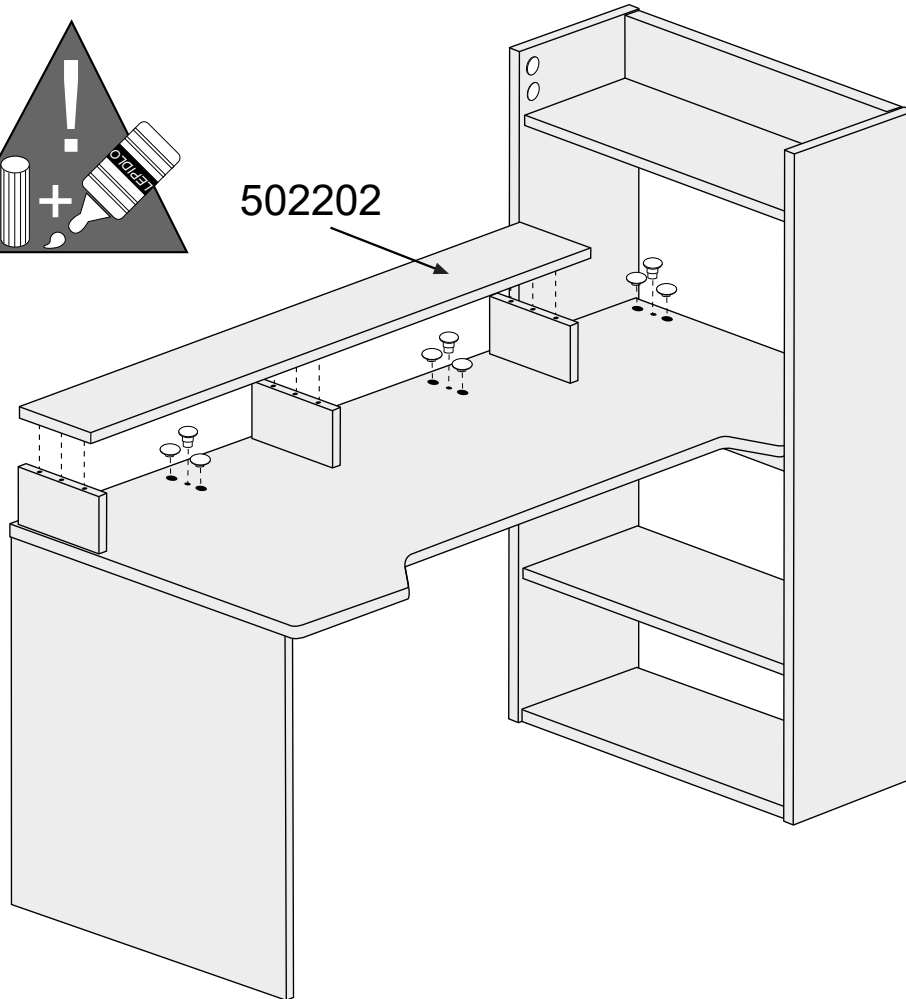
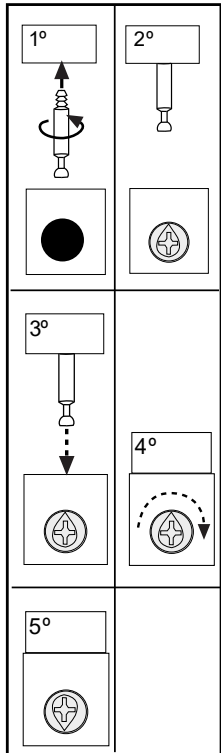

15b

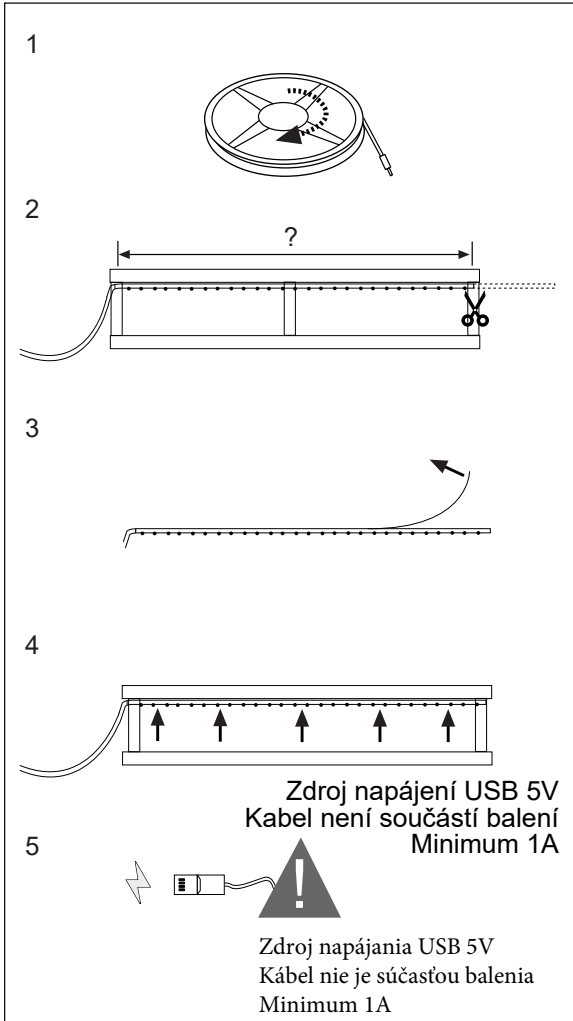

cm 0 1 2
TP3515 x1

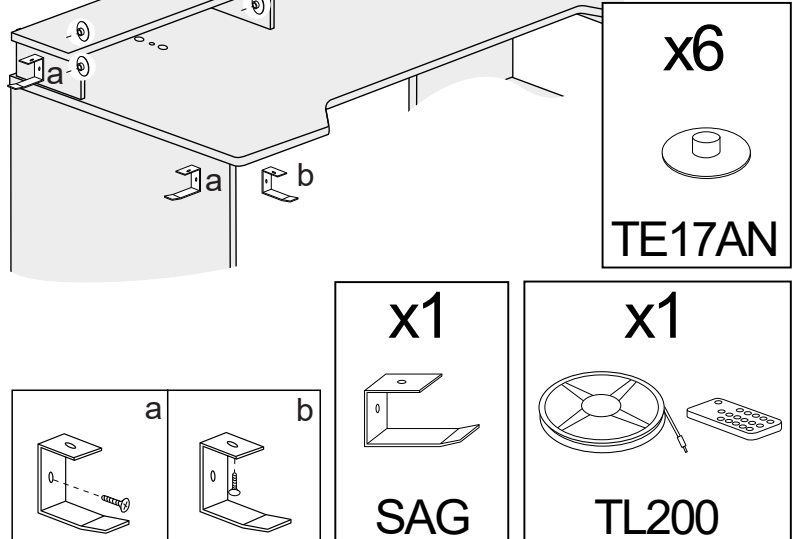
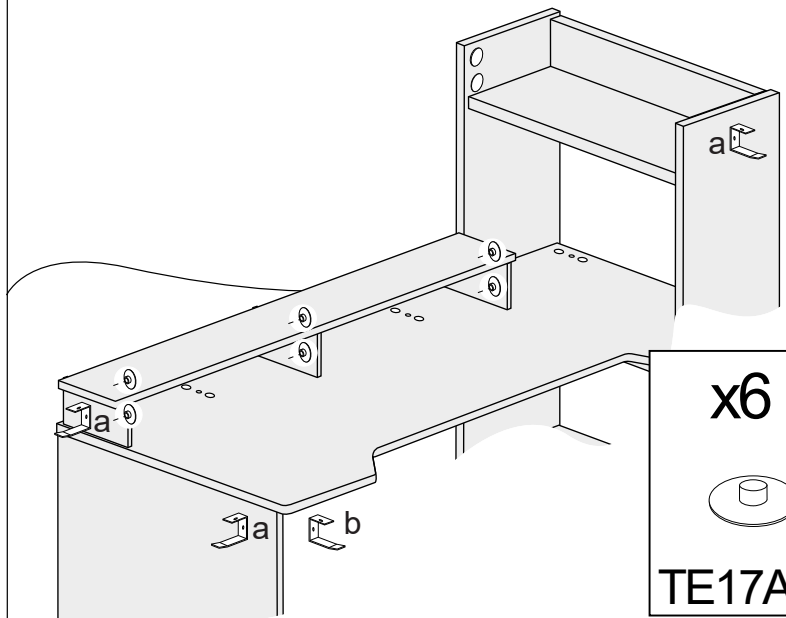

x1

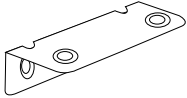

EA2020

16b

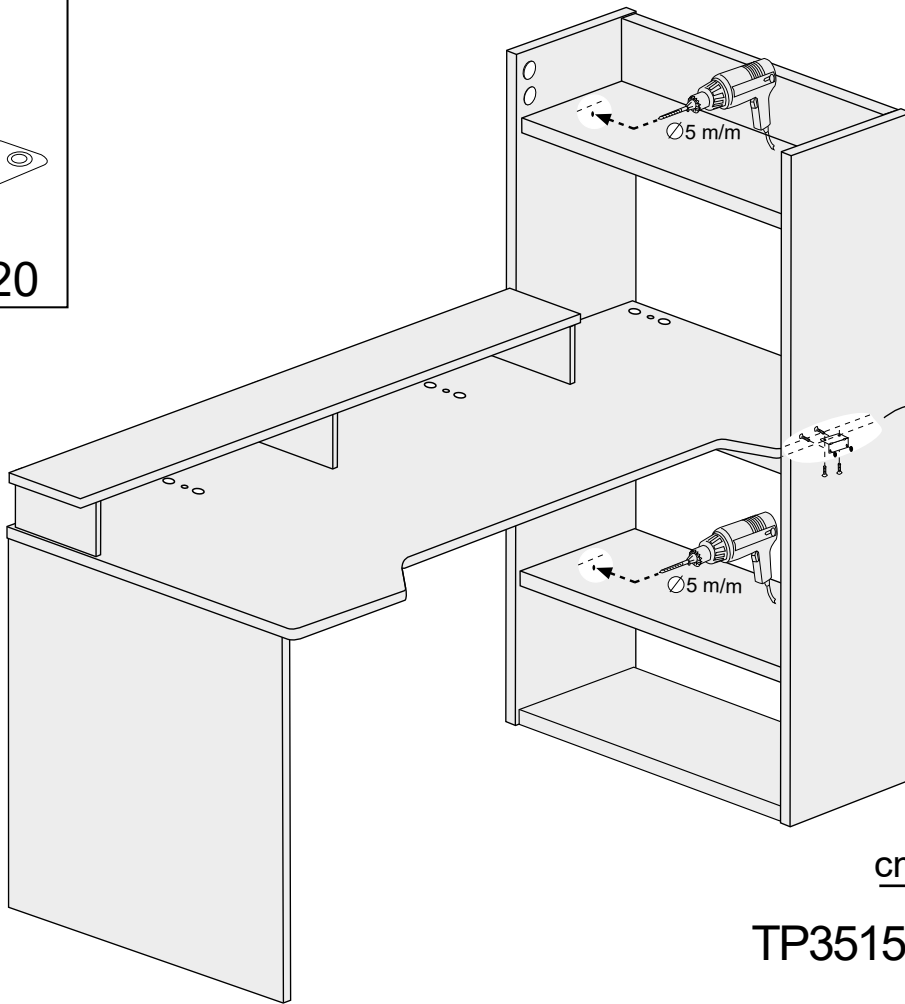

cm 0 1 2

TP3515  x4

cm 0 1 2

TP3525  x4

NENÍ SOUČÁSTÍ
BALENÍ
NIE JE SÚČASŤOU
BALENIA

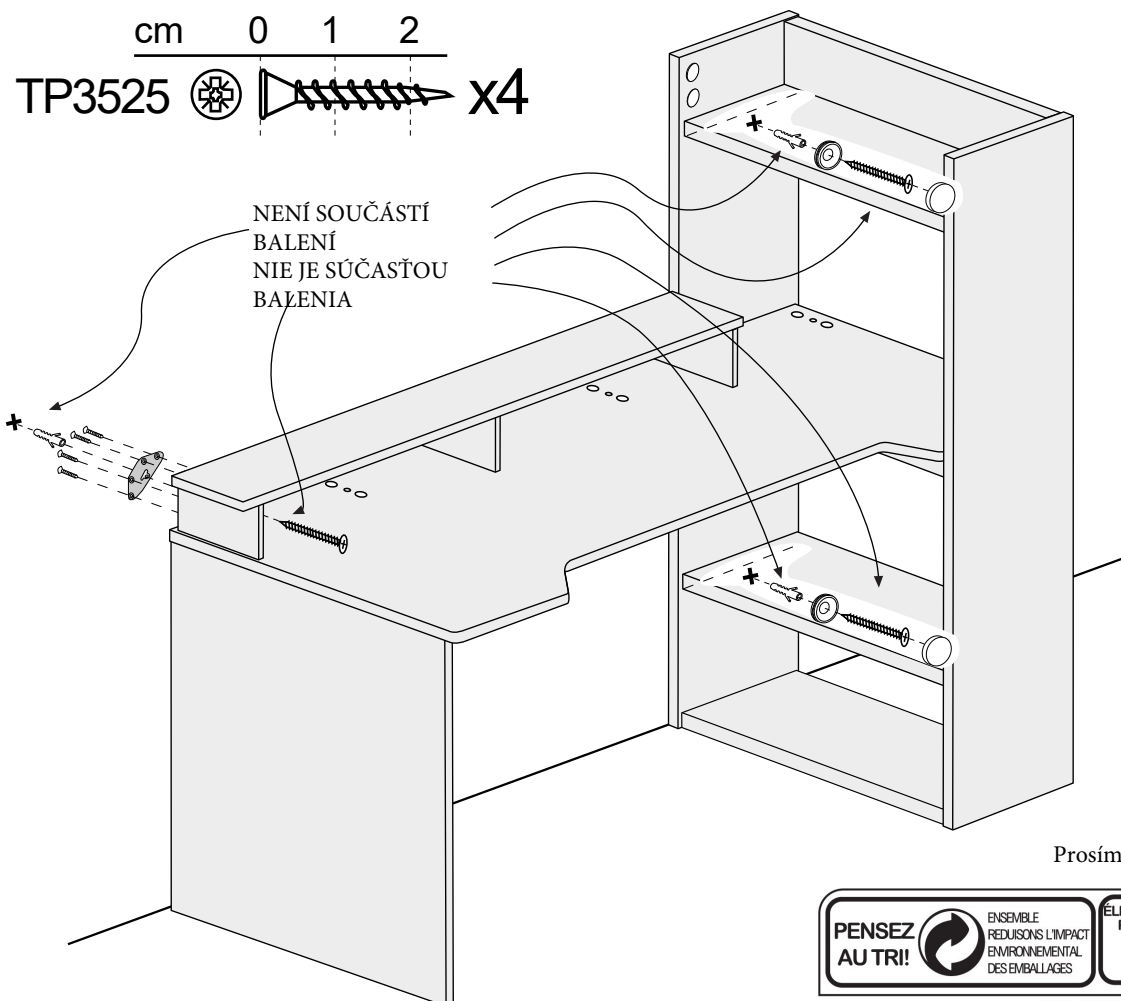

17b

x2

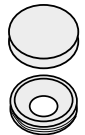

TEMB18C

x1

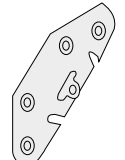

ECG

Prosím recyklujte

