

# SILK 2 TYP 30, TYP 70 28\_SK2

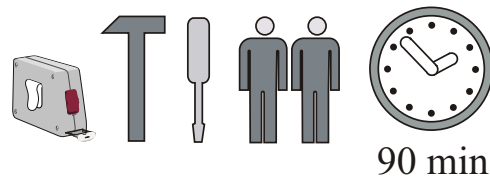

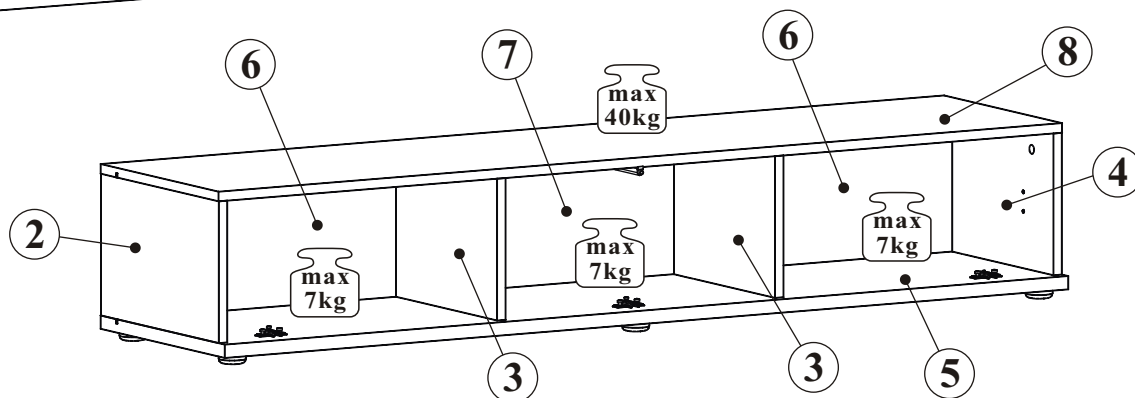

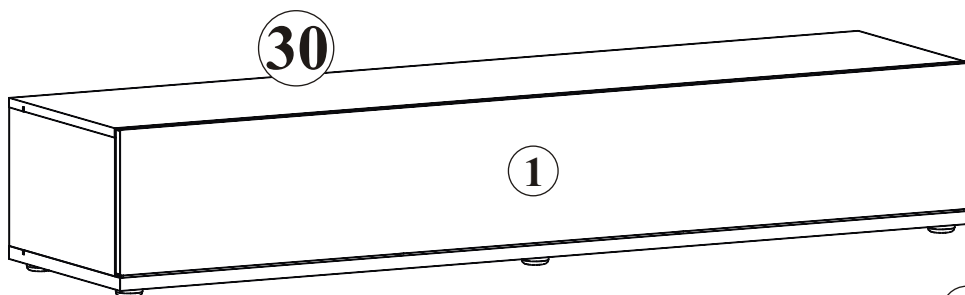

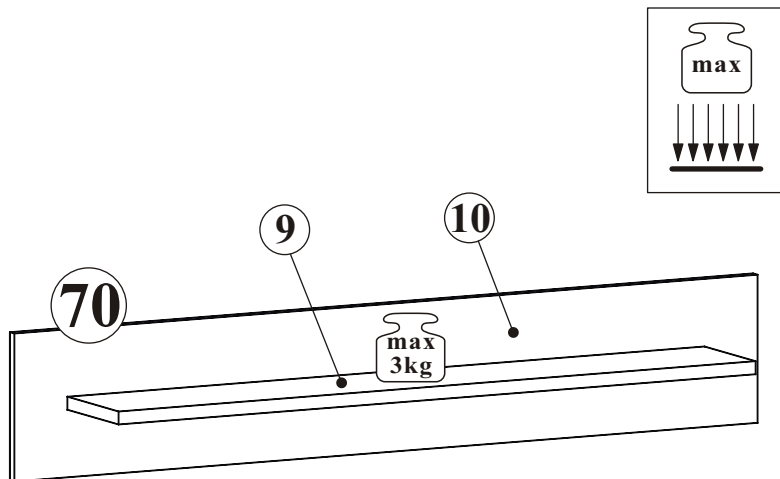
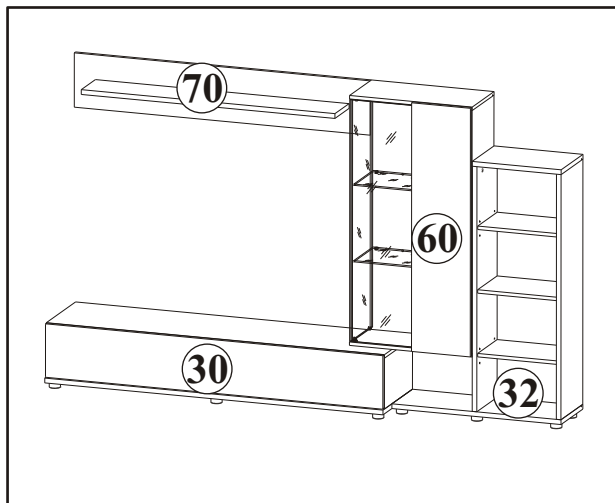
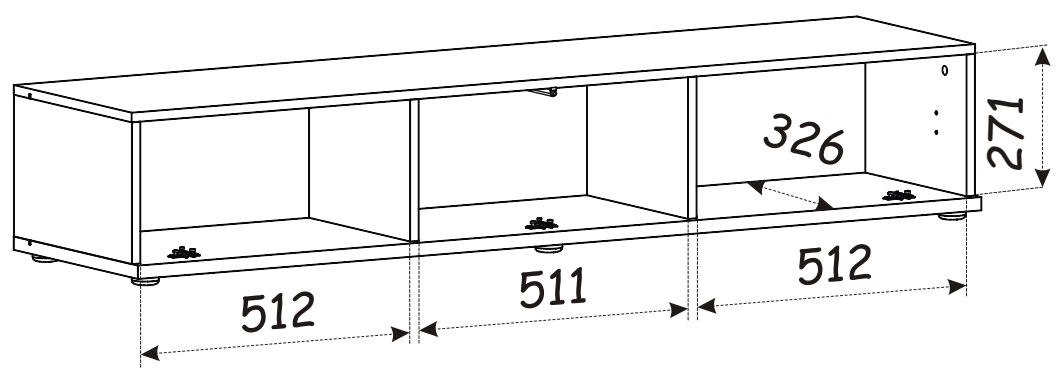
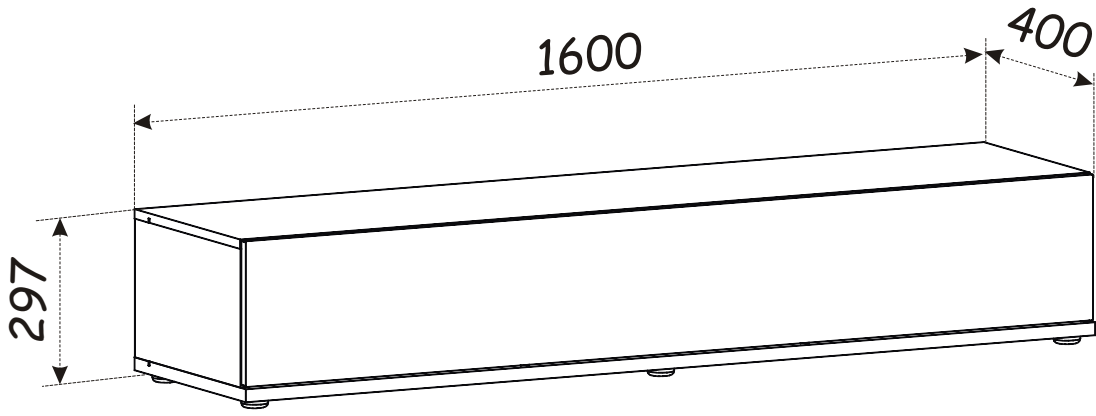
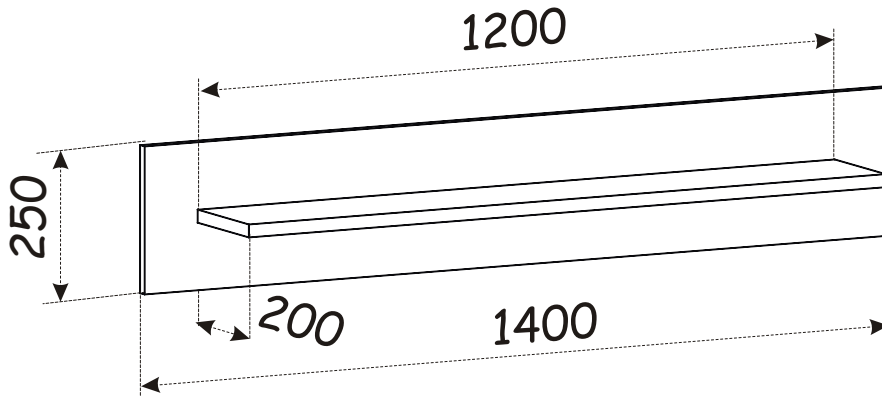
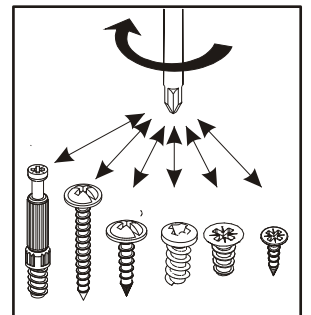
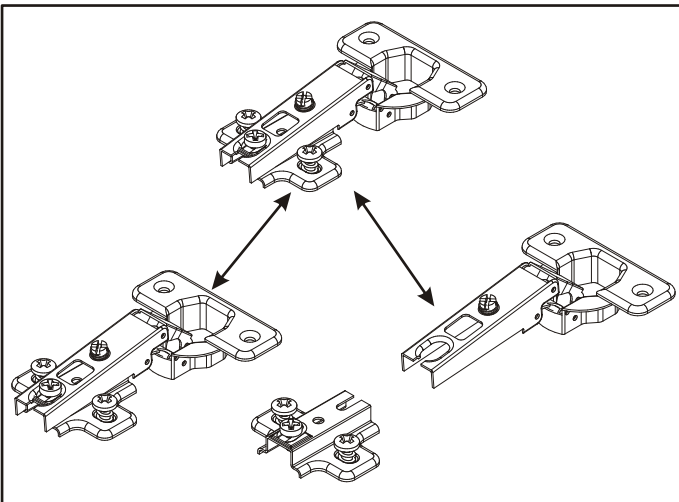
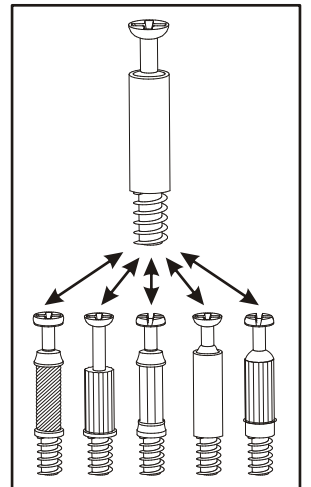
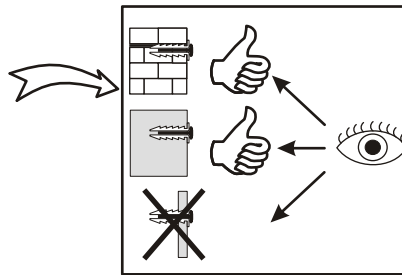
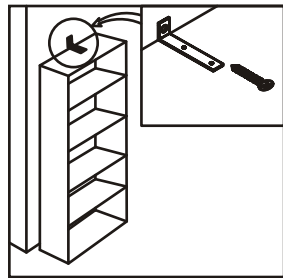
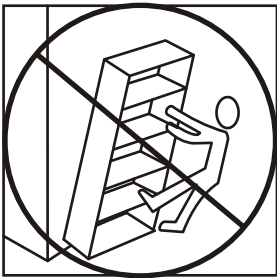
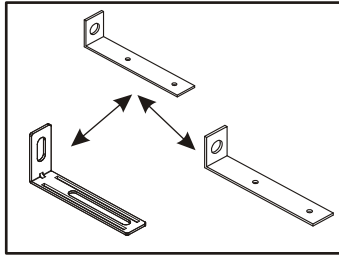
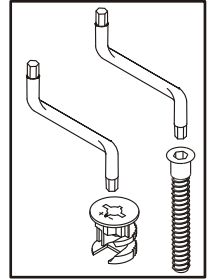
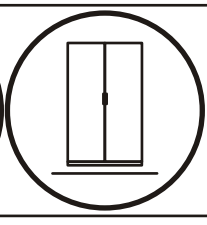
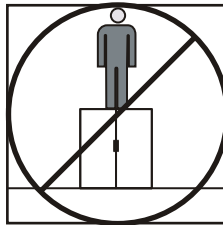
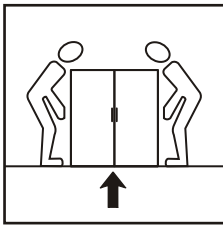
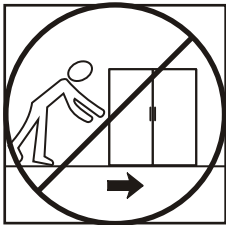
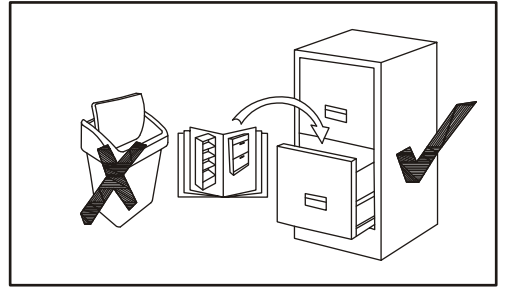
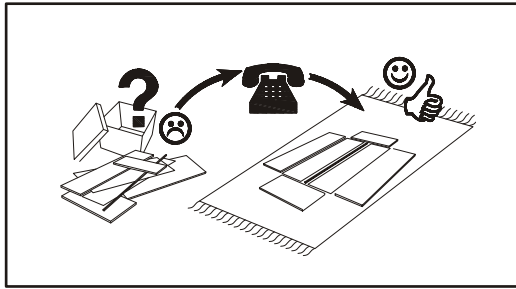
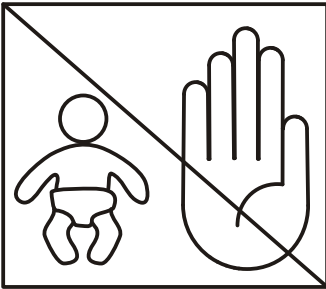
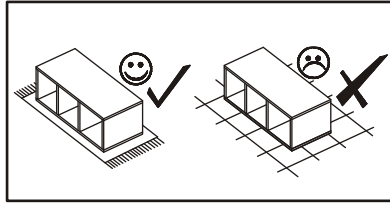
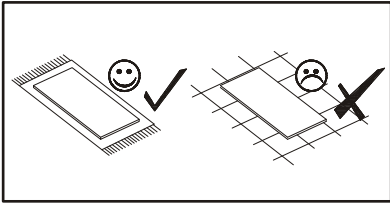



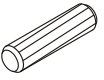
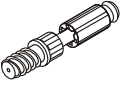
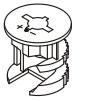

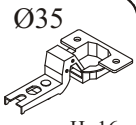
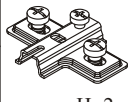

| NO | DIM  |     | COL.-NO | QTY |
|----|------|-----|---------|-----|
| 1  | 1596 | 246 | 16 1/3  | 1   |
| 2  | 234  | 380 | 16 1/3  | 1   |
| 3  | 234  | 326 | 16 1/3  | 2   |
| 4  | 234  | 380 | 16 1/3  | 1   |
| 5  | 1600 | 400 | 22 1/3  | 1   |
| 6  | 246  | 526 | 3 1/3   | 2   |
| 7  | 246  | 527 | 3 1/3   | 1   |
| 8  | 1600 | 380 | 16 1/3  | 1   |
| 9  | 1200 | 184 | 22 1/3  | 1   |
| 10 | 1400 | 250 | 16 1/3  | 1   |



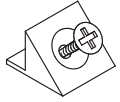
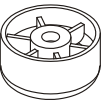
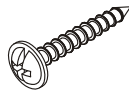
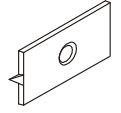

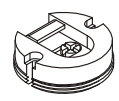
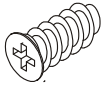
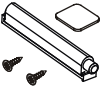
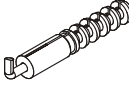
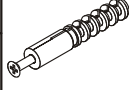
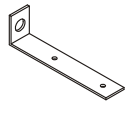
SILK 2 TYP 30, TYP 70

|   |  |  |   |  |  |
|---|--|--|---|--|--|
| A1<br>x20<br><br>ø8x36       | B4<br>x8<br>              | B5<br>x8<br><br>Ø15x12      | G5<br>x8<br>              | B11<br>x13<br><br>Ø7x50 | G4<br>x13<br>             |
| E25<br>x3<br><br>Ø35<br>H=16 | E4<br>x3<br><br>H=2       | D10<br>x14<br><br>USØ3,5x13 | G21<br>x2<br>             | D7<br>x6<br><br>USØ3x16 | S1<br>x14<br>             |
| ST7<br>x6<br><br>Ø50, h=25   | UP11<br>x6<br><br>UPØ4X20 | G16<br>x2<br>               | UP13<br>x2<br><br>UPØ3x16 | ZM1<br>x3<br>           | D20<br>x6<br><br>ESØ6x9,5 |
| OD2<br>x1<br>                | KR3<br>x3<br><br>Ø10      | KR1<br>x1<br>               | L1<br>x1<br>              | G2<br>x1<br>            |  |

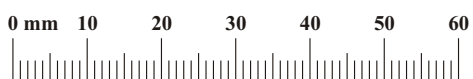



1 - 4

70



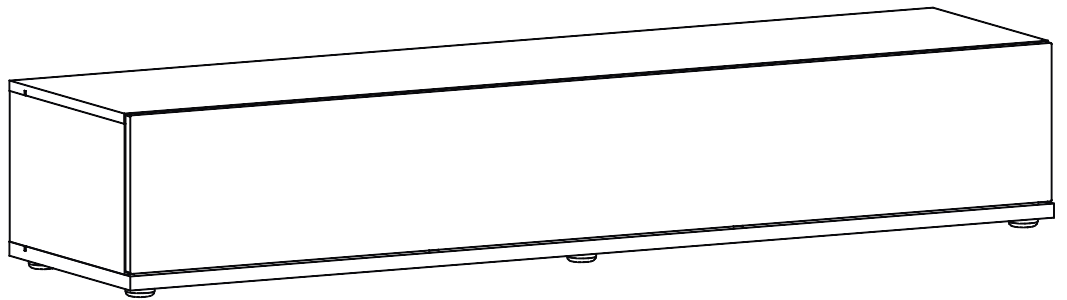

5 - 15

30

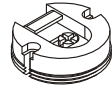

SILK 2 TYP 70

1

|     |   |     |   |
|-----|---|-----|---|
| ZM1 |  | D20 |  |
| x3  |   | x6  | ESØ6x9,5  |

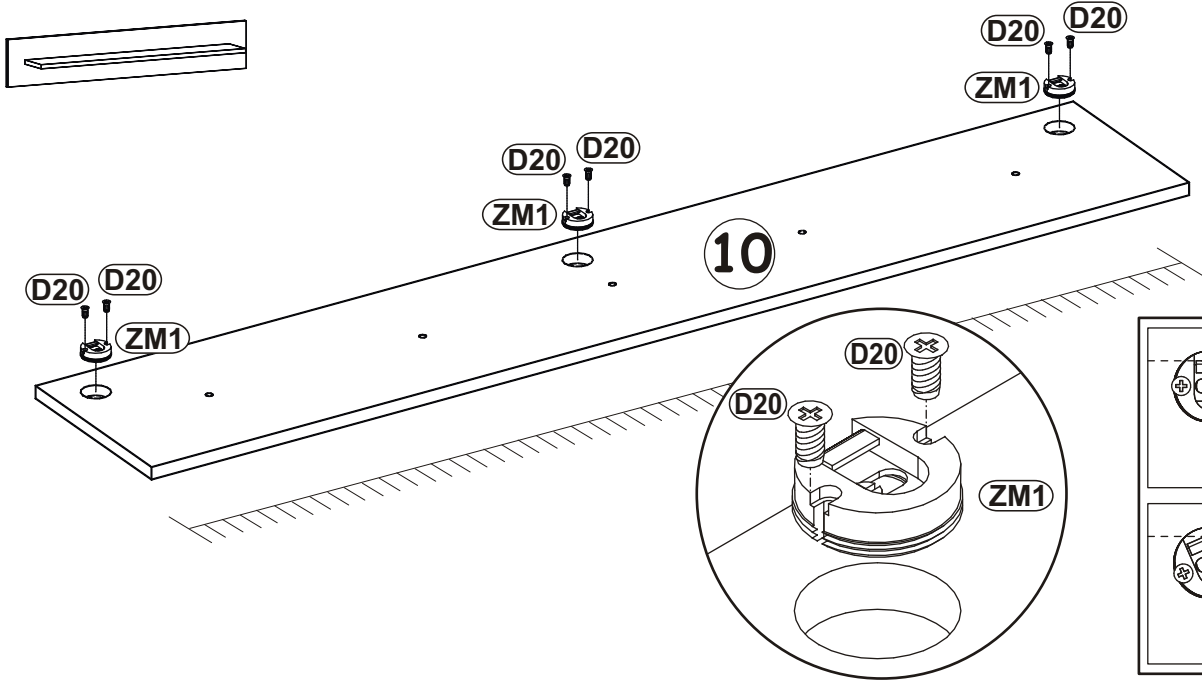

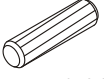

2

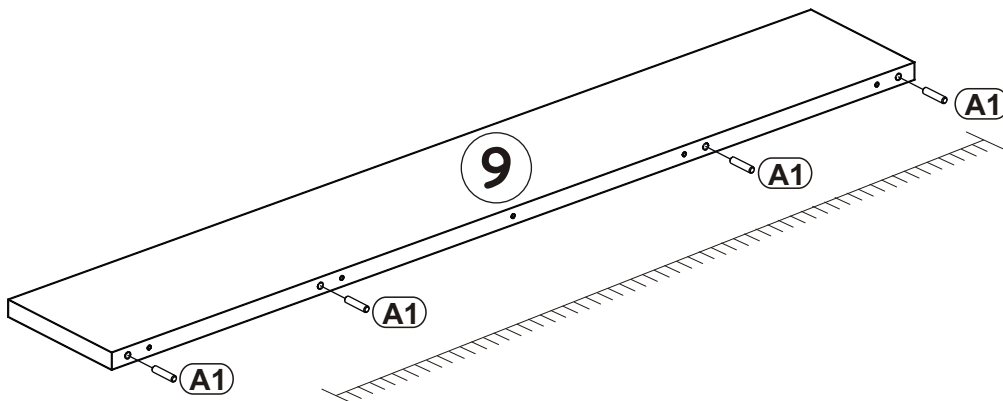
|    |  |
|----|--|
| A1 |  |
| x4 | ø8x36  |



3

|     |   |    |   |
|-----|---|----|---|
| B11 |  | G4 |  |
| x5  | Ø7x50   | x5 |   |

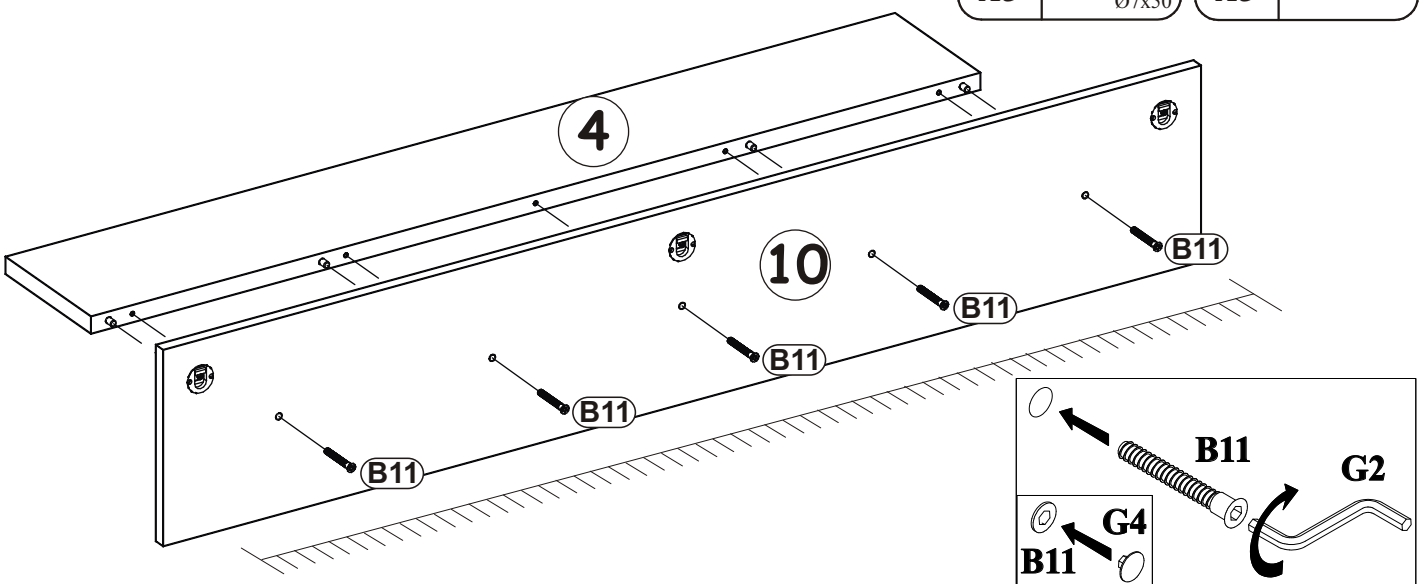

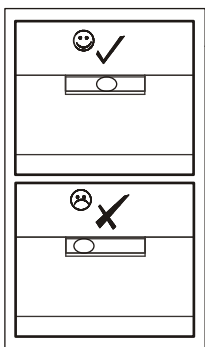
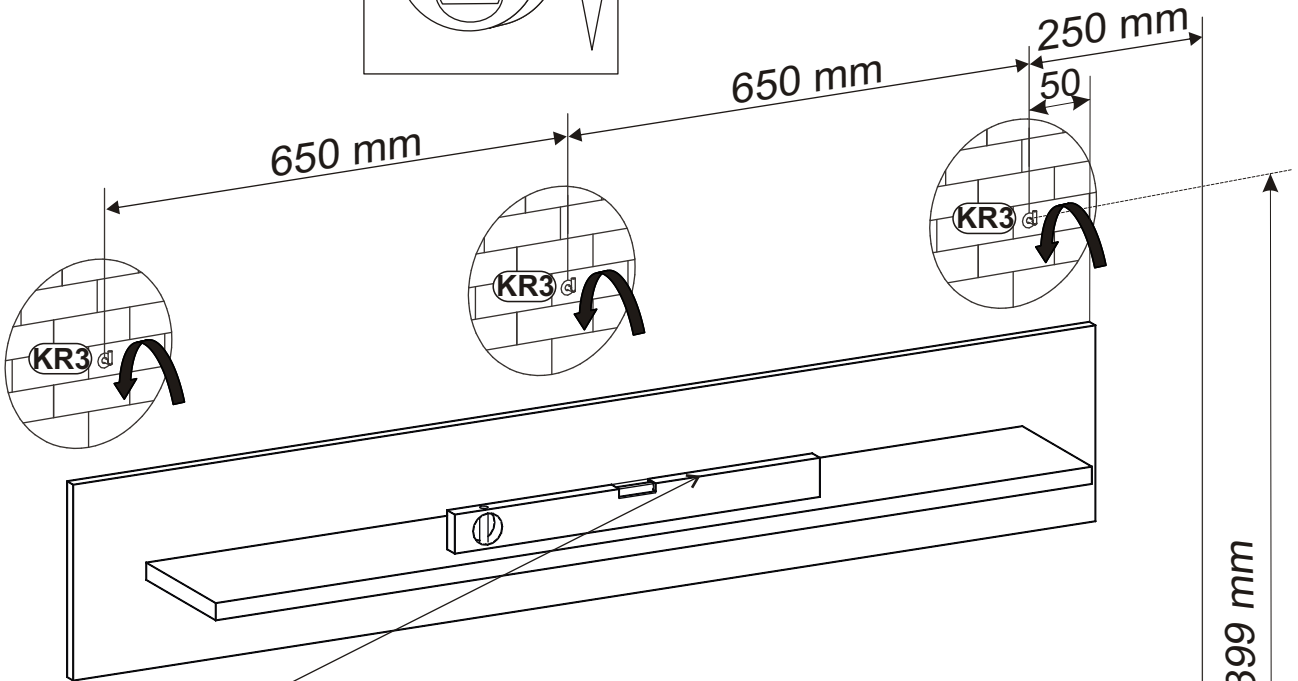
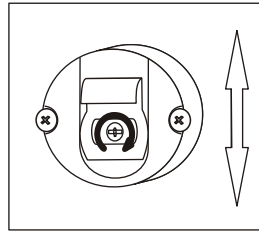
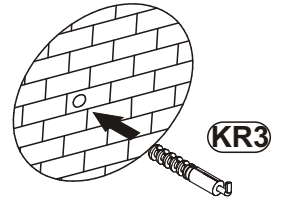
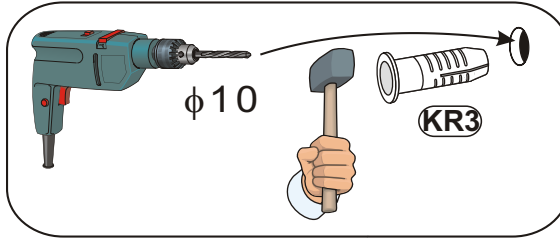
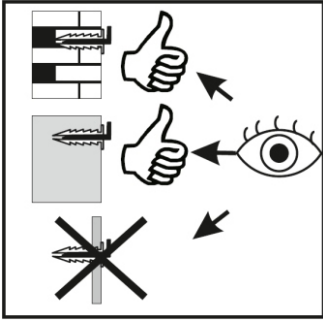
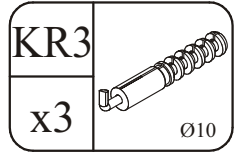
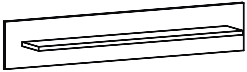

SILK 2 TYP 70

4



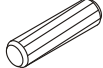

5

|    |   |
|----|---|
| A1 |  |
| x8 | ø8x36   |

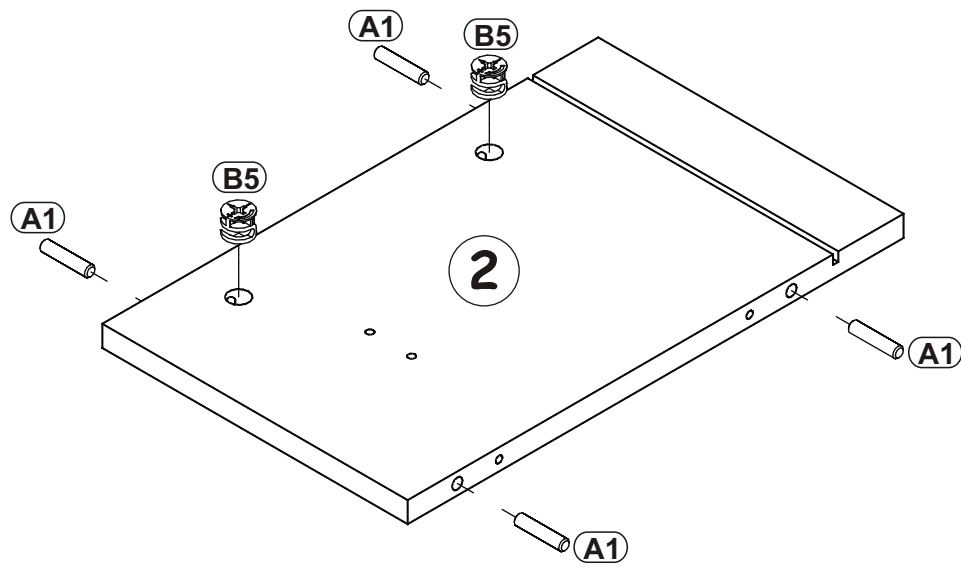
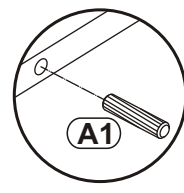
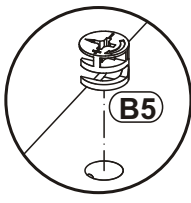
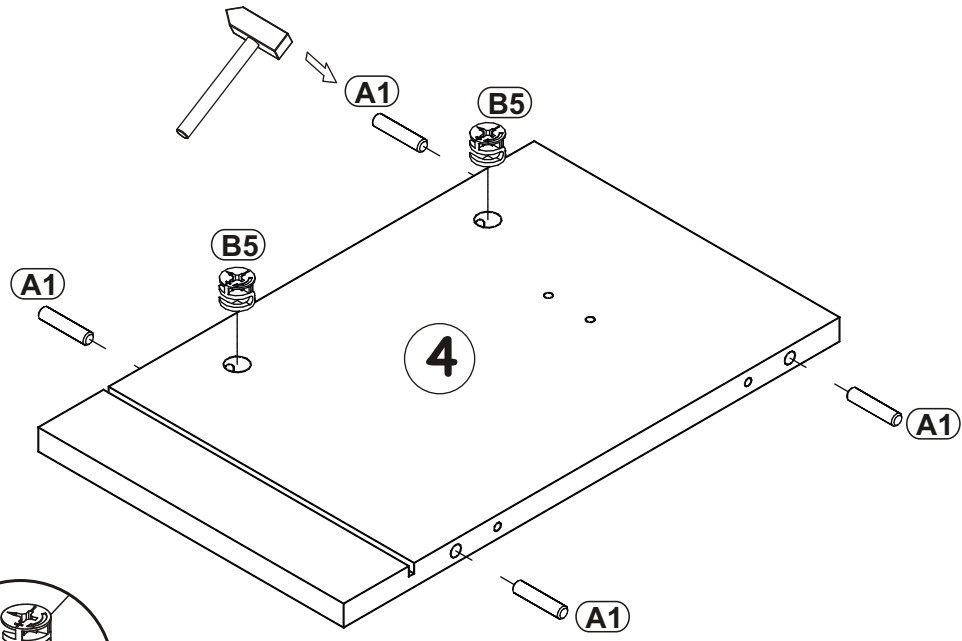
|    |   |
|----|---|
| B5 |  |
| x4 | Ø15x12  |



6

|    |   |    |   |
|----|---|----|---|
| A1 |  | B5 |  |
| x8 | ø8x36   | x4 | Ø15x12  |

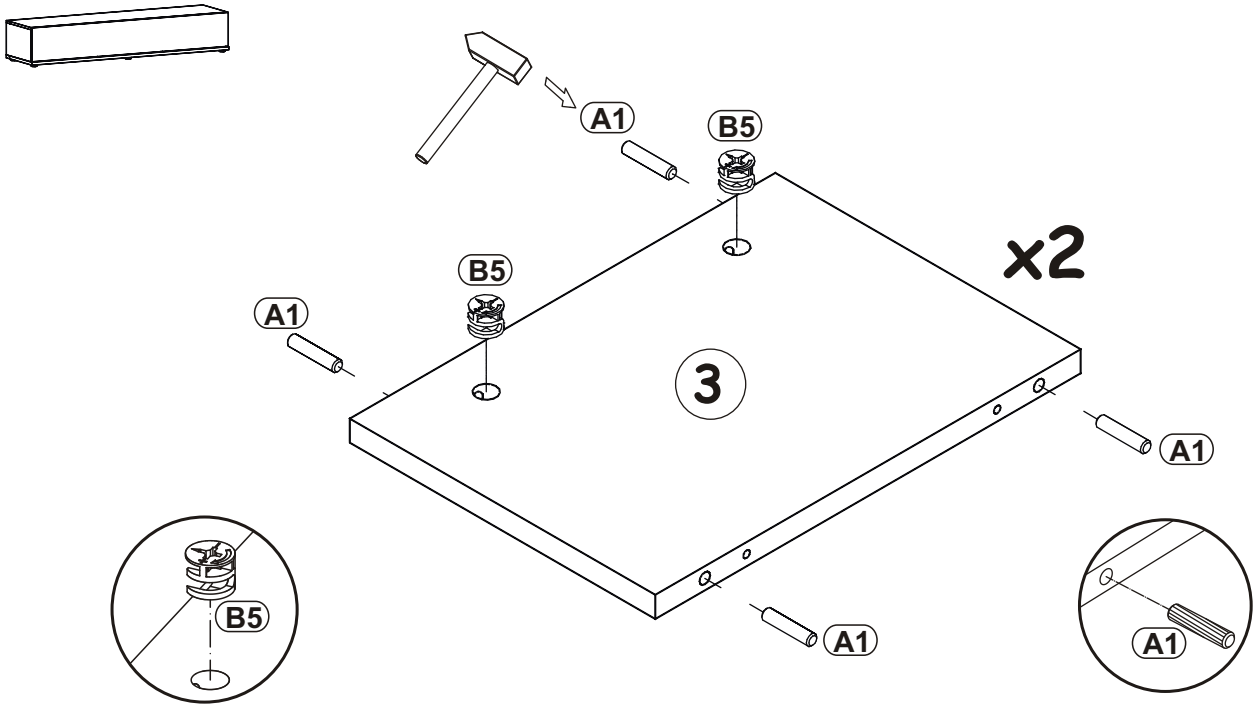

7

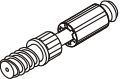
|    |   |
|----|---|
| B4 |  |
| x8 |   |

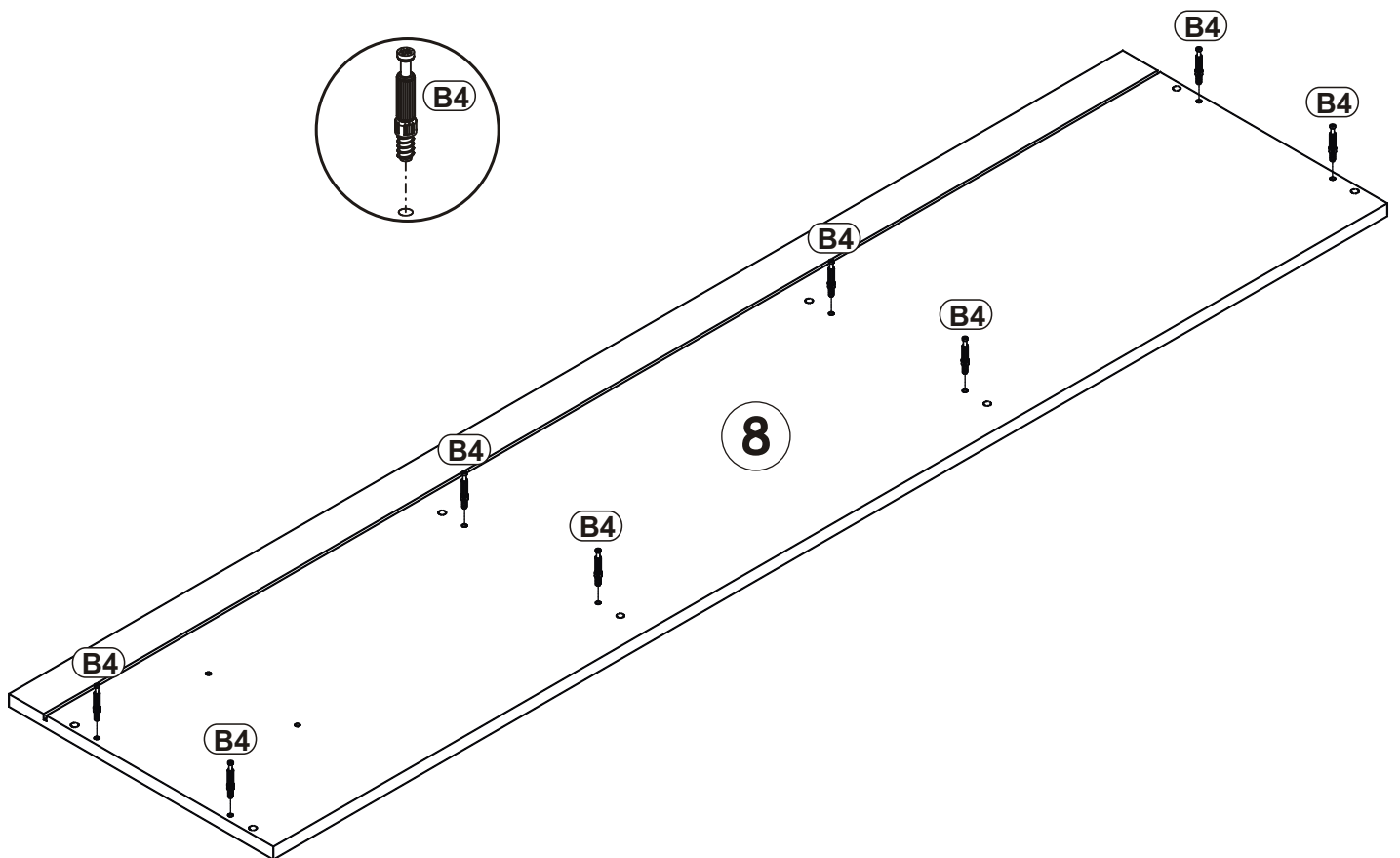

SILK 2 TYP 30

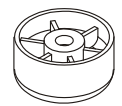
|     |   |
|-----|---|
| ST7 |  |
| x6  | Ø50, h=25   |

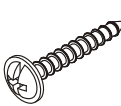
|      |  |
|------|--|
| UP11 |  |
| x6   | UPØ4X20  |

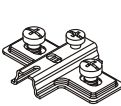
|    |  |
|----|--|
| E4 |  |
| x3 | H=2  |

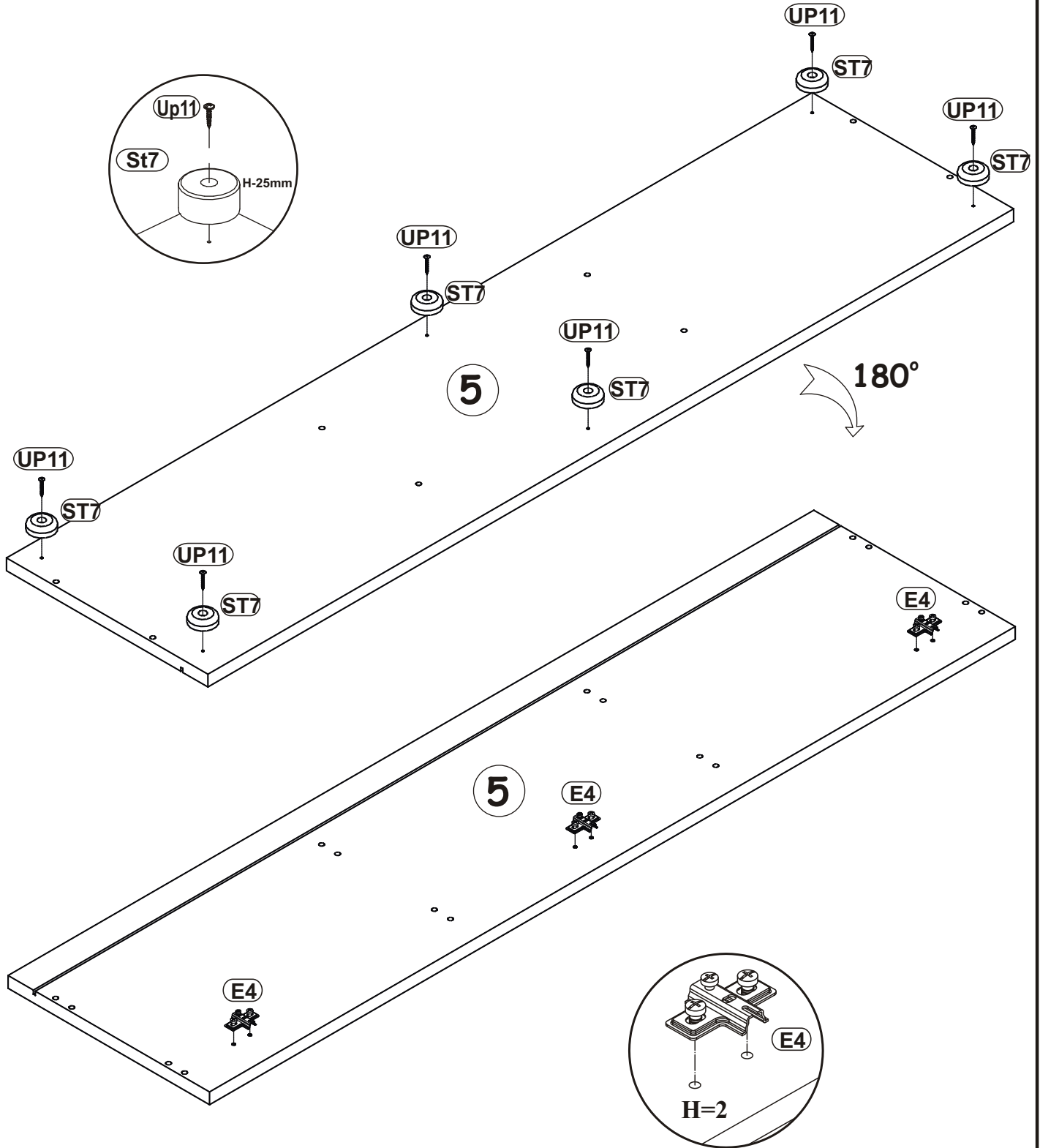

8

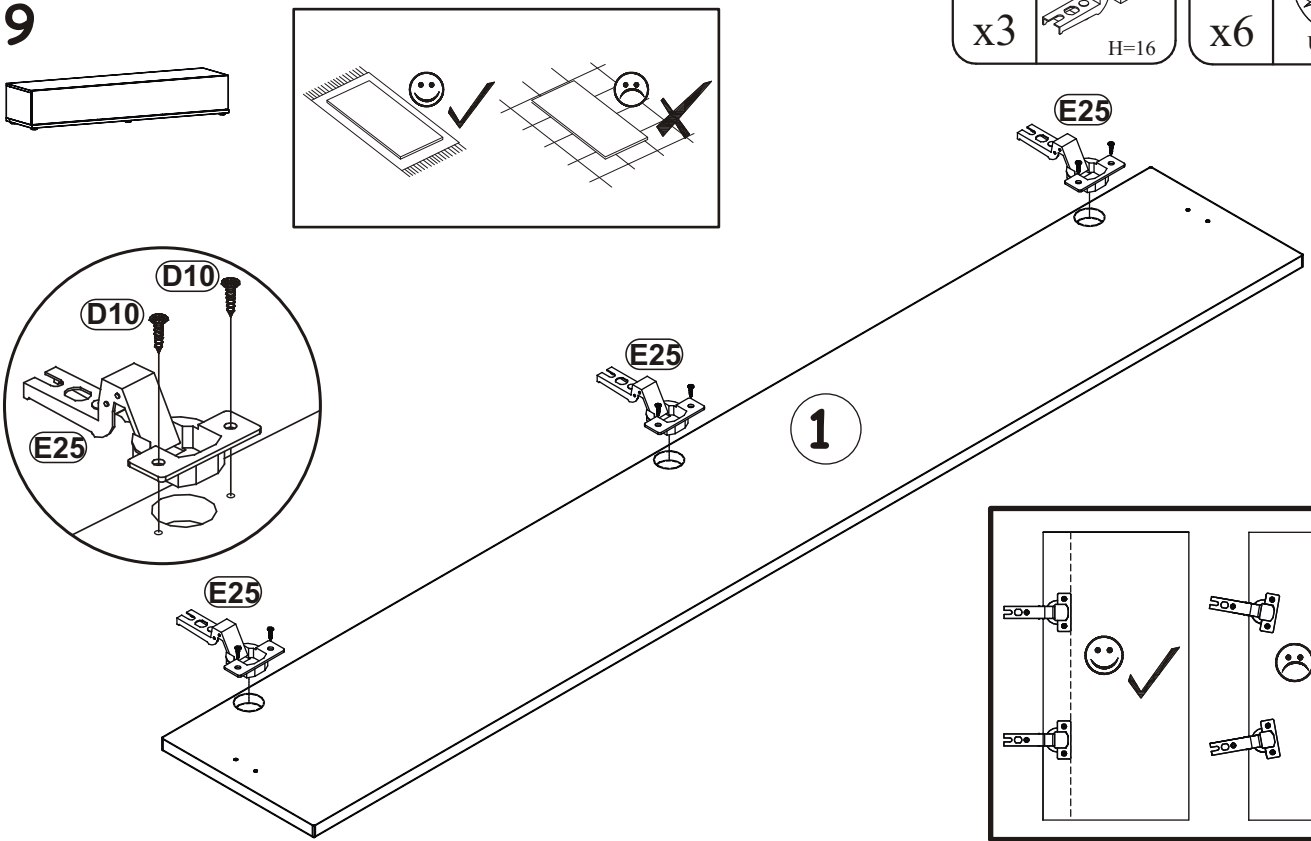

SILK 2 TYP 30

|     |             |     |  |
|-----|-------------|-----|--|
| E25 | Ø35<br>H=16 | D10 | <br>USØ3,5x13 |
| x3  |             | x6  |  |



|     |  |    |   |
|-----|--|----|---|
| B11 | <br>Ø7x50 | G4 |  |
| x8  |  | x8 |   |

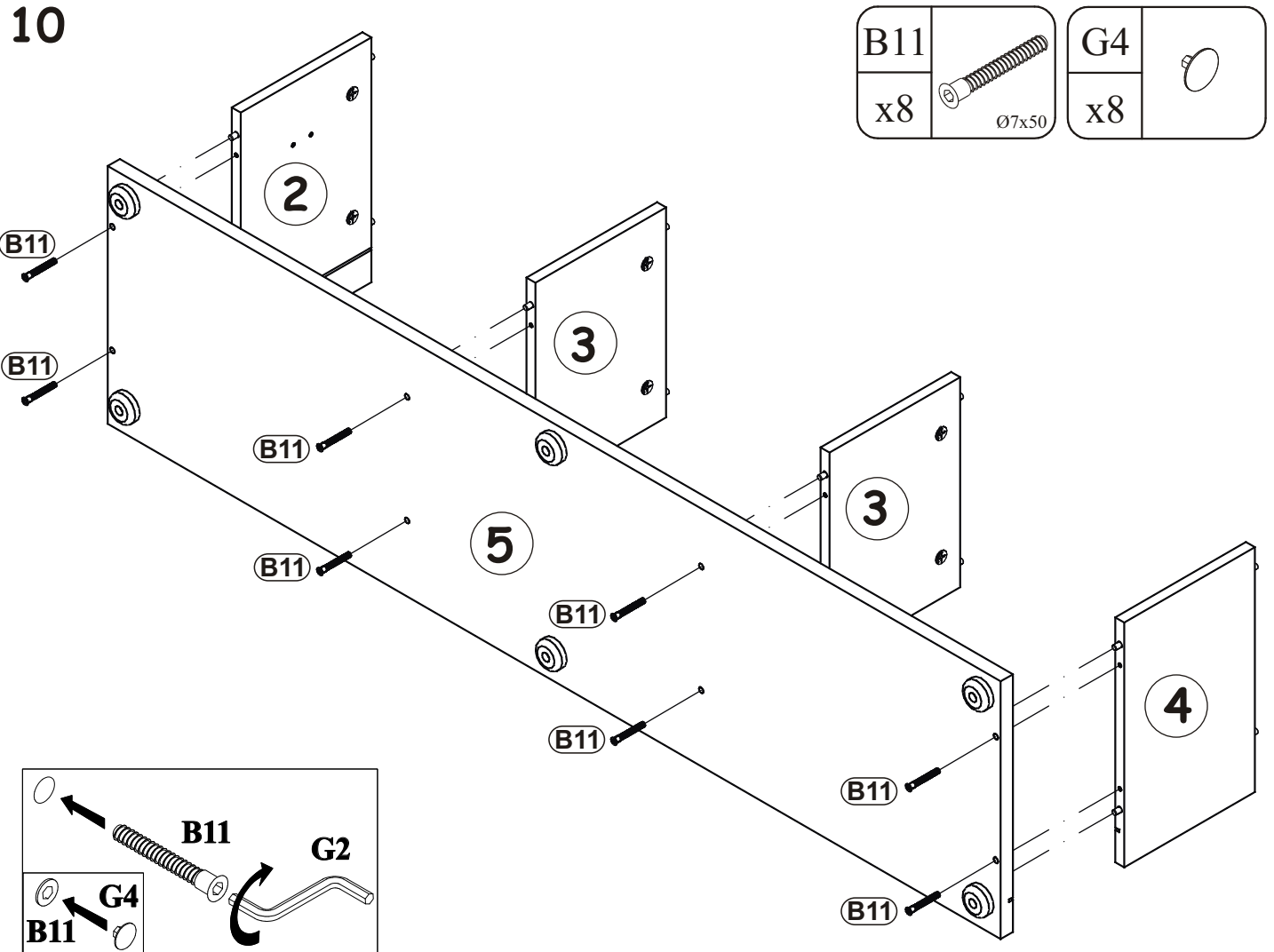

SILK 2 TYP 30

11

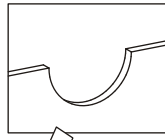

G5

x8

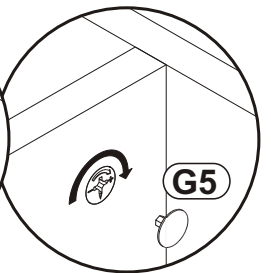
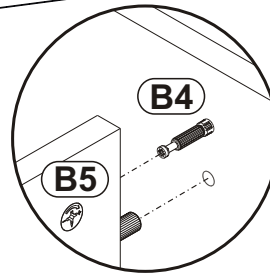
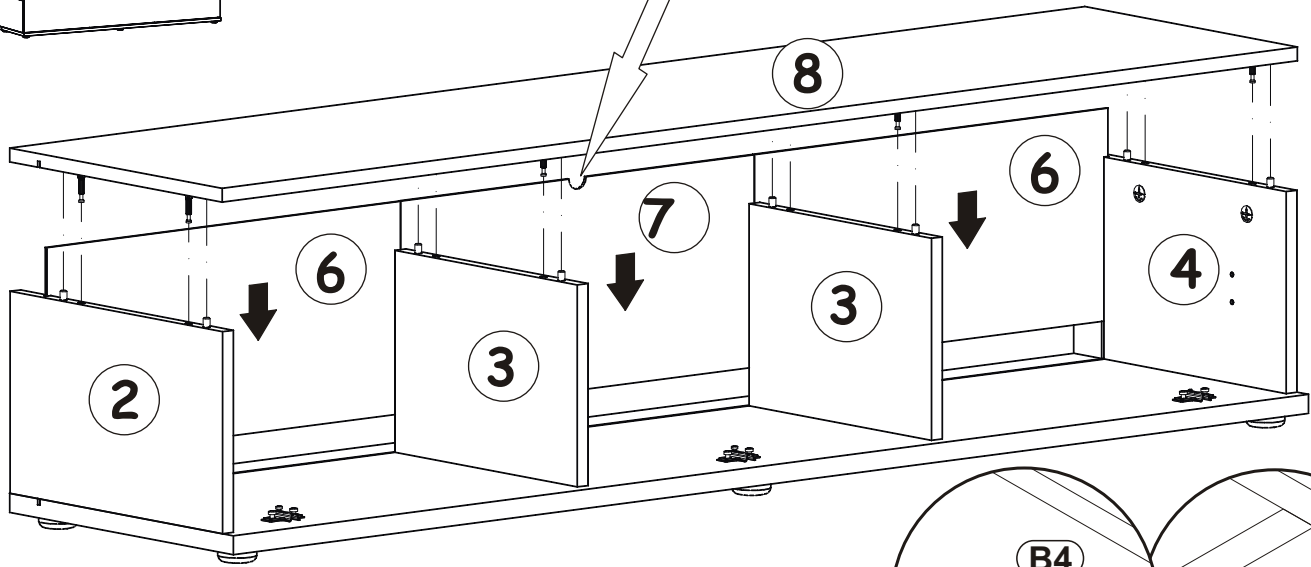

12

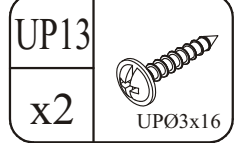
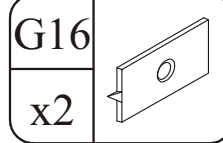
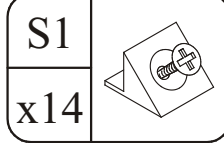

X=y 90°

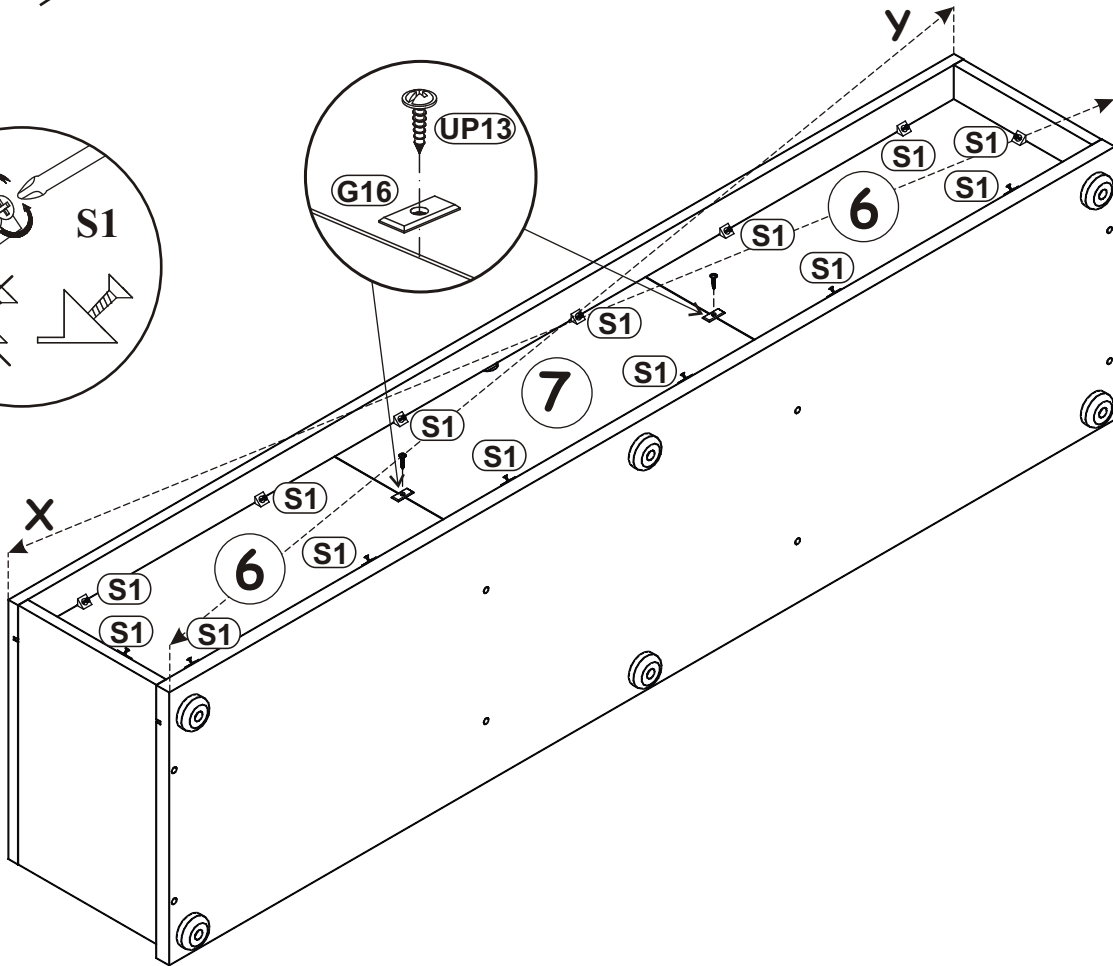
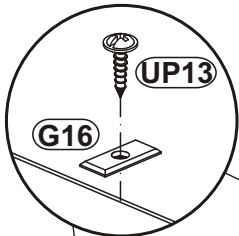
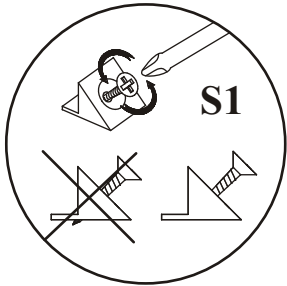



|    |  |     |  |     |           |
|----|--|-----|--|-----|-----------|
| L1 |  | KR1 |  | D10 |           |
| x1 |  | x1  |  | x2  | USØ3,5x13 |

13

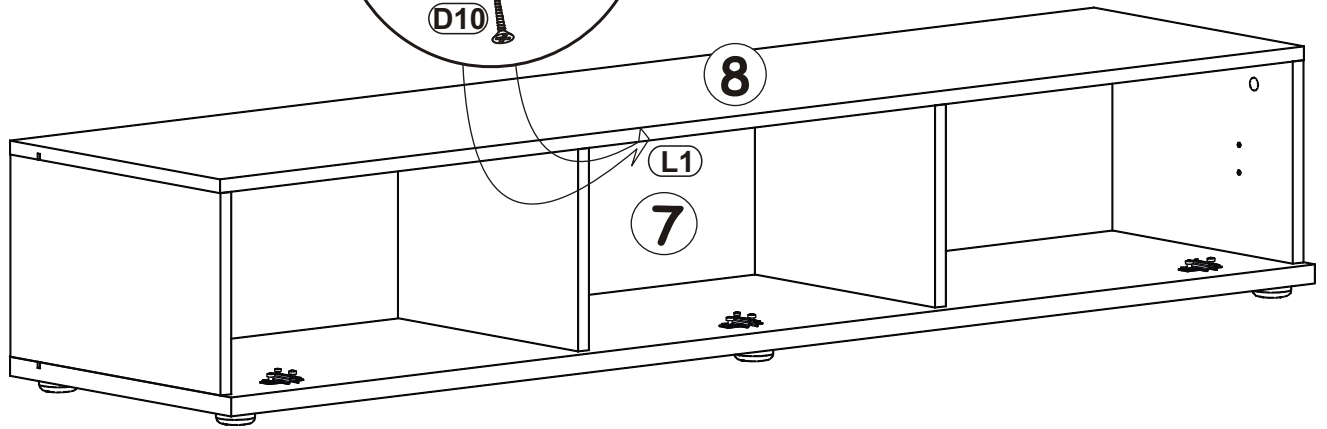
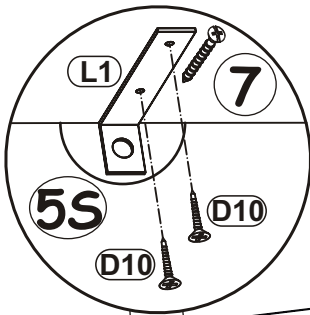
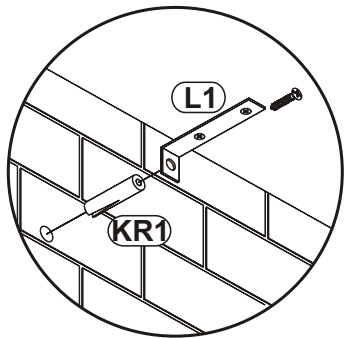
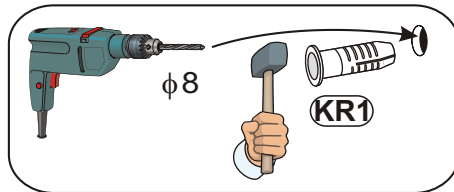
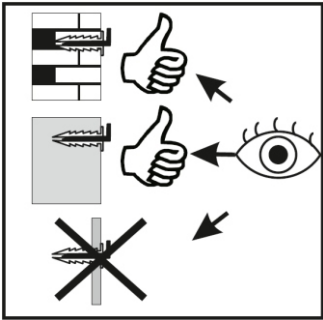

14

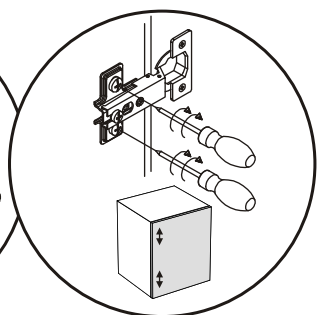
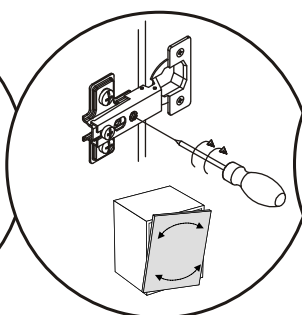
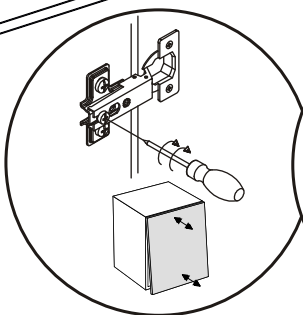
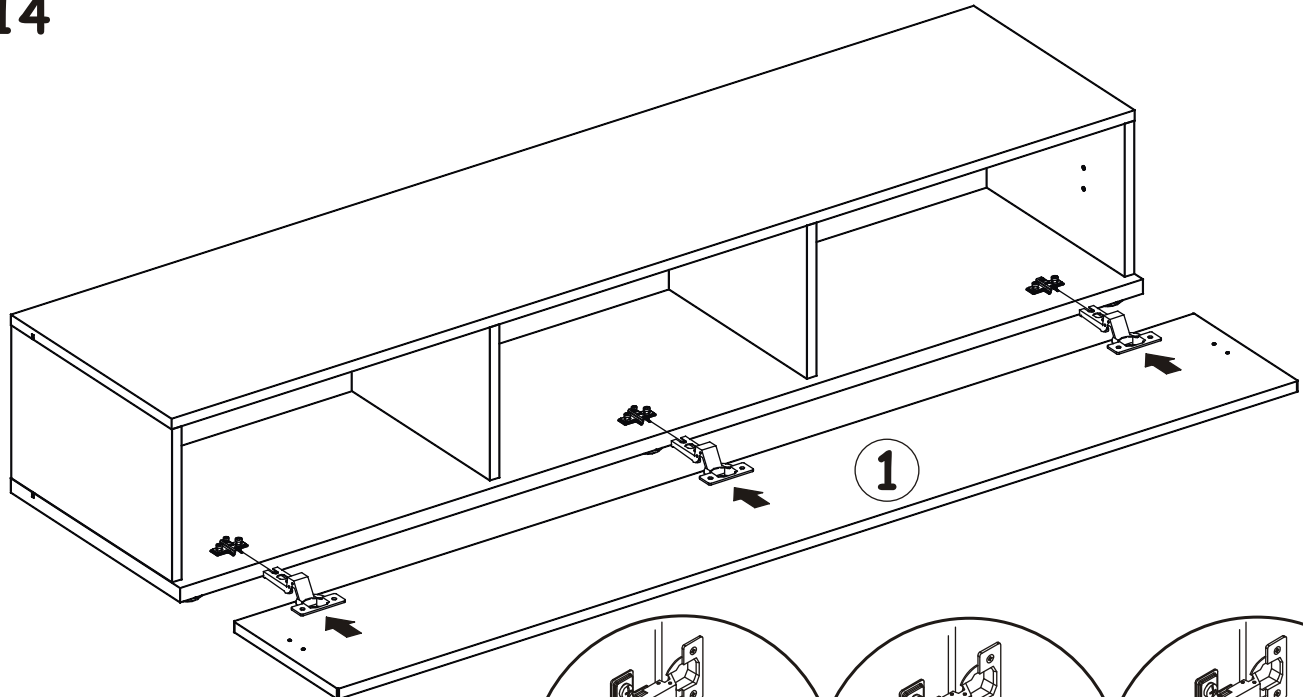

15

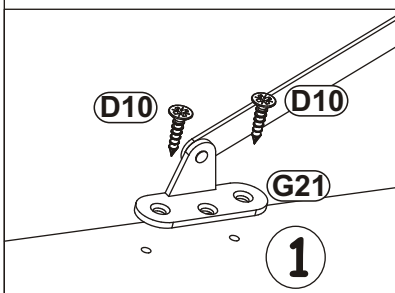
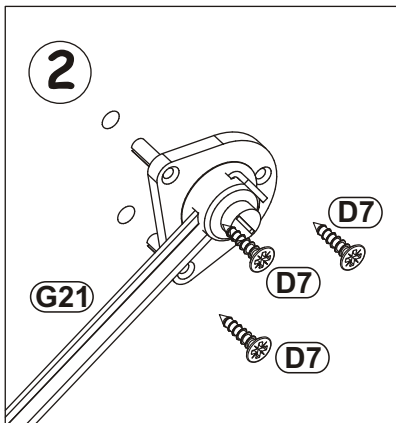
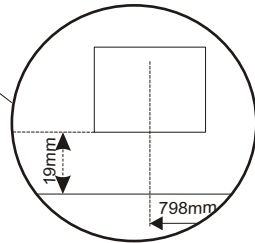
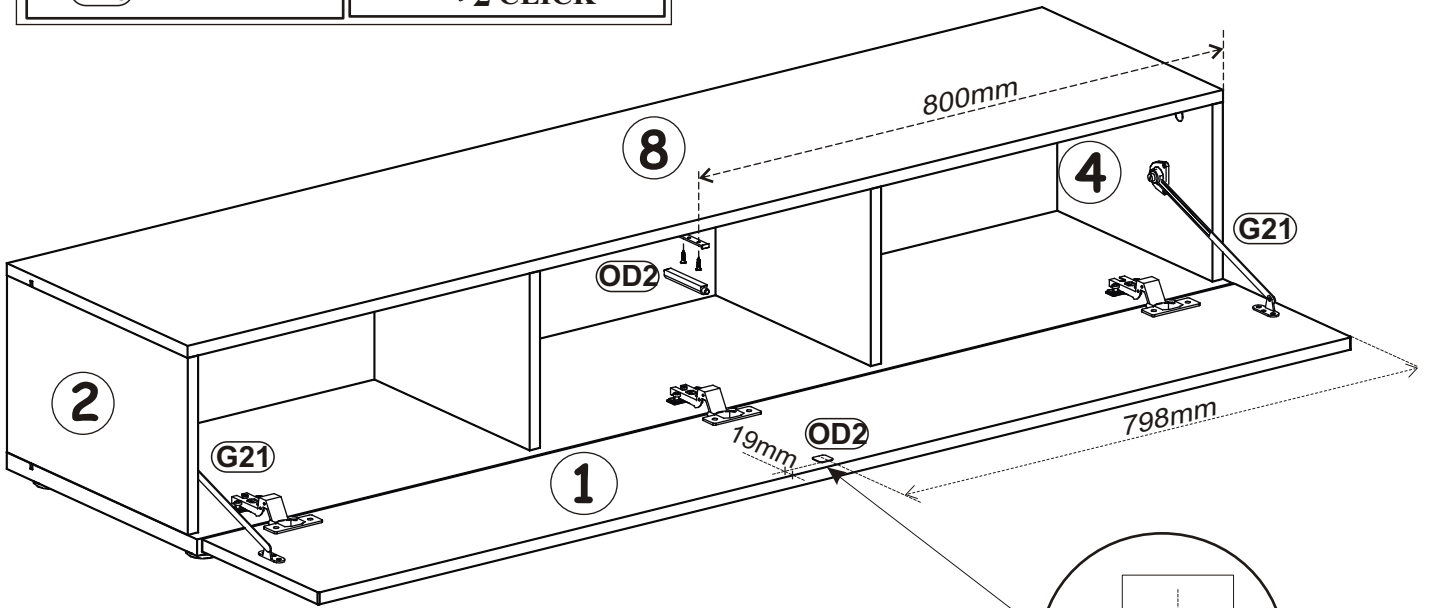
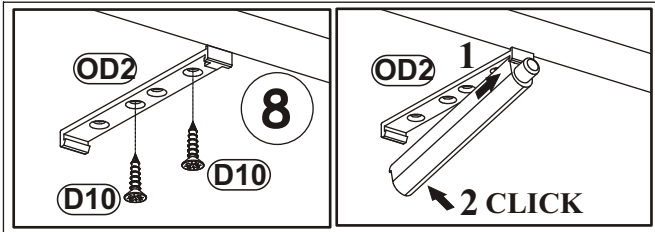
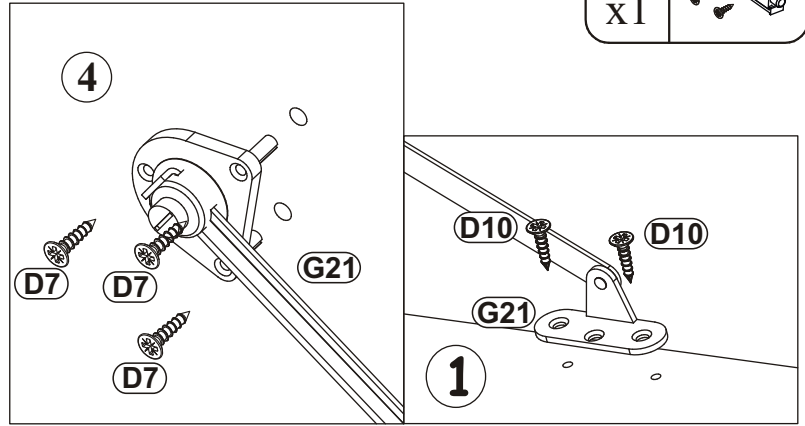
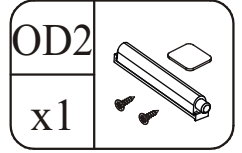
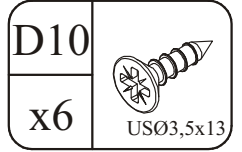
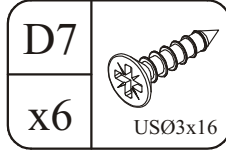
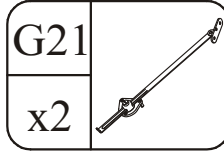

# SILK 2 TYP 32 28\_SK2

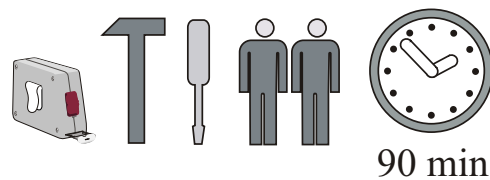
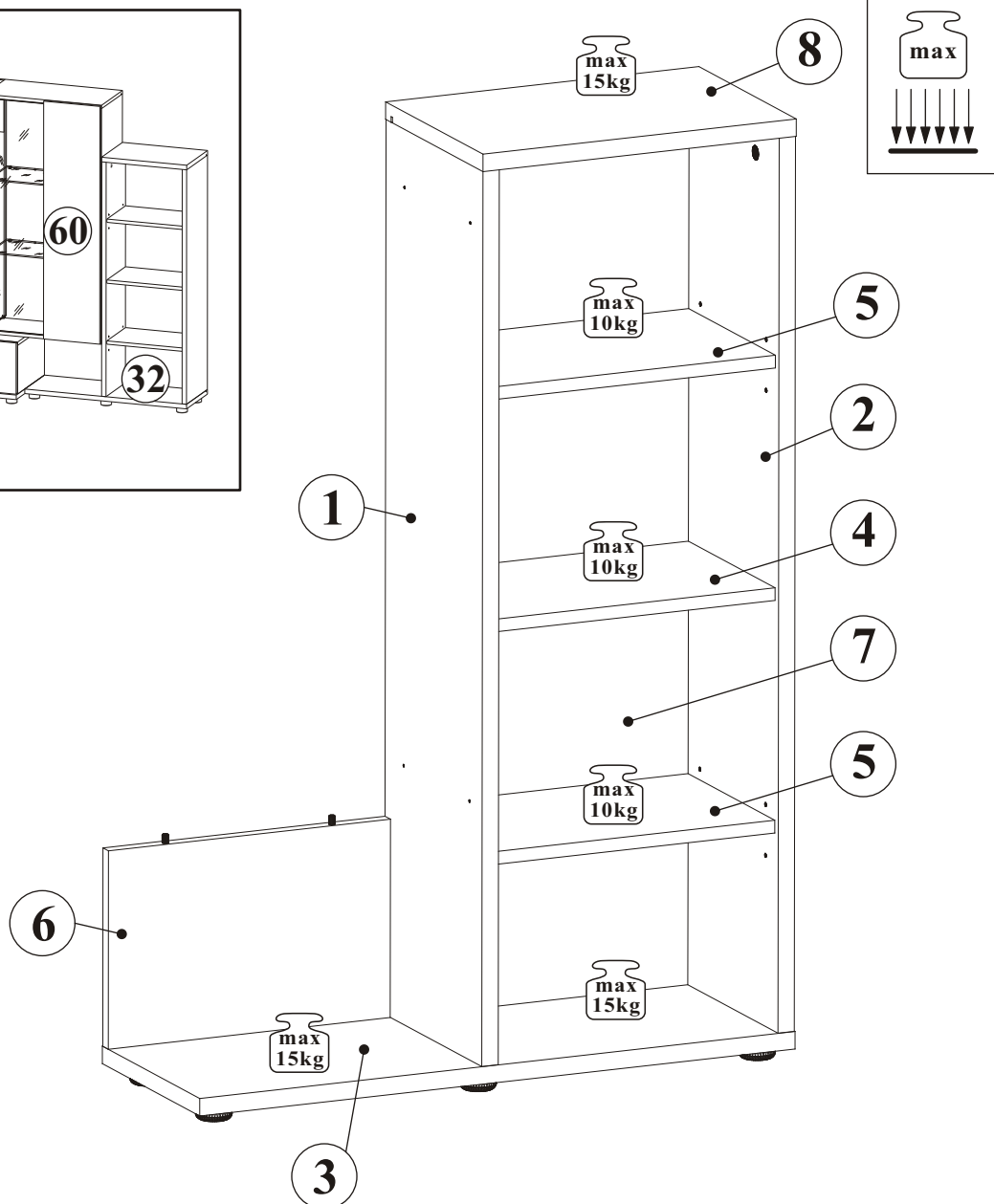
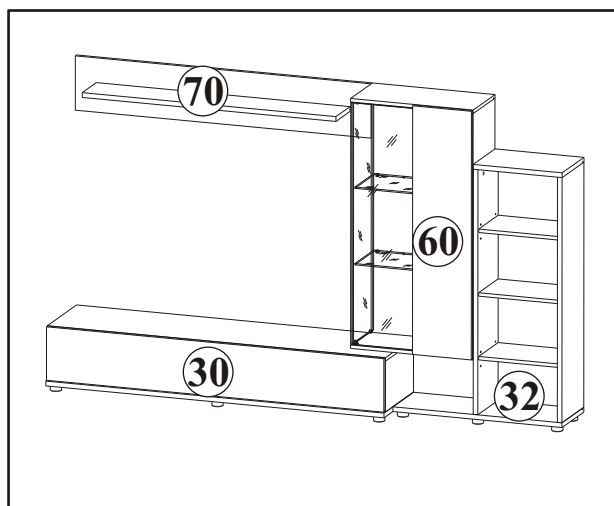





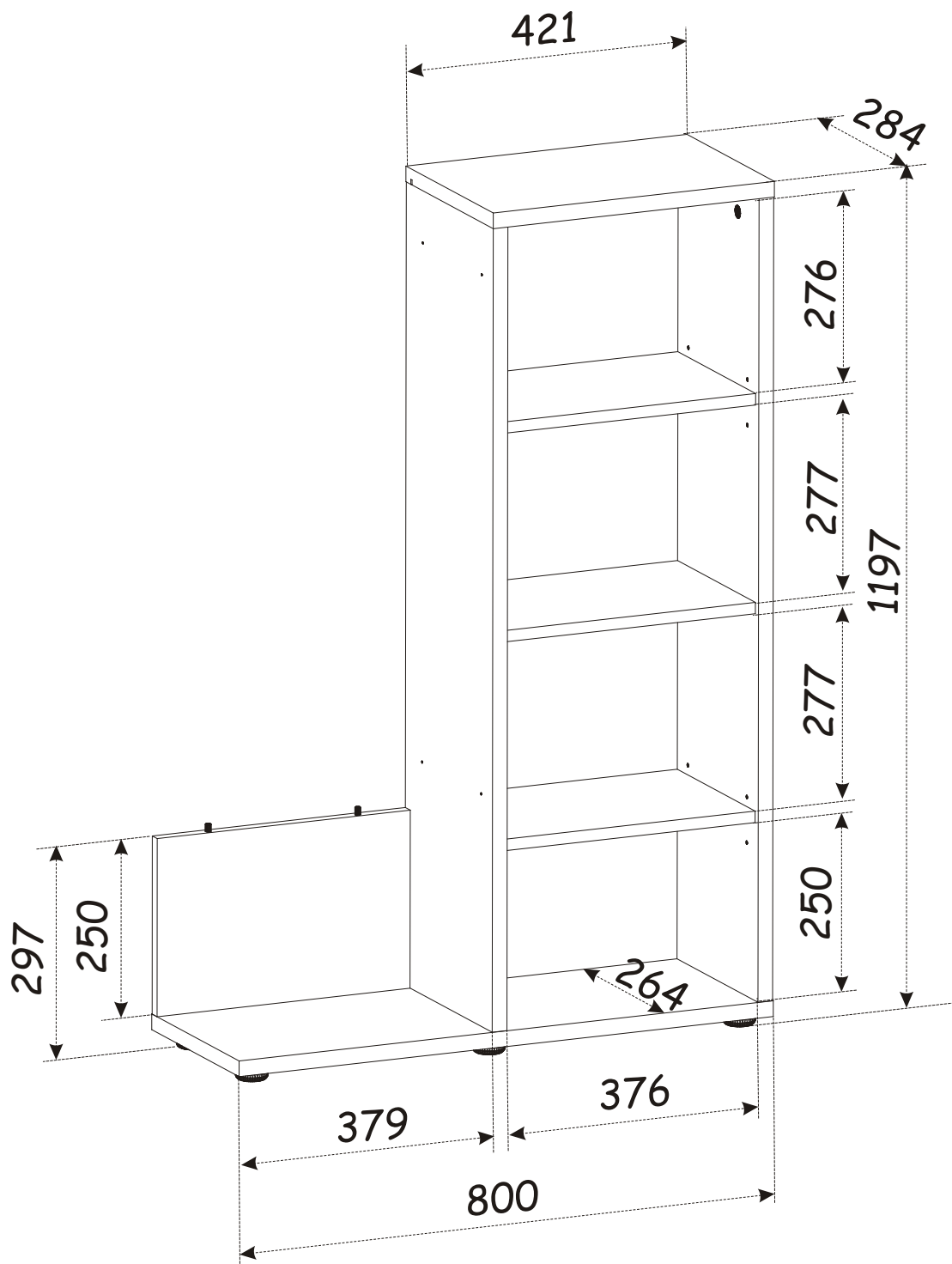

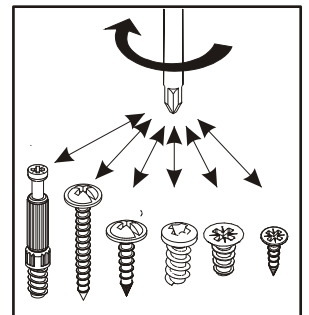
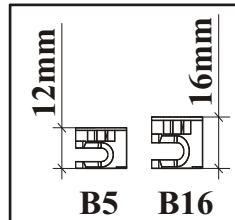
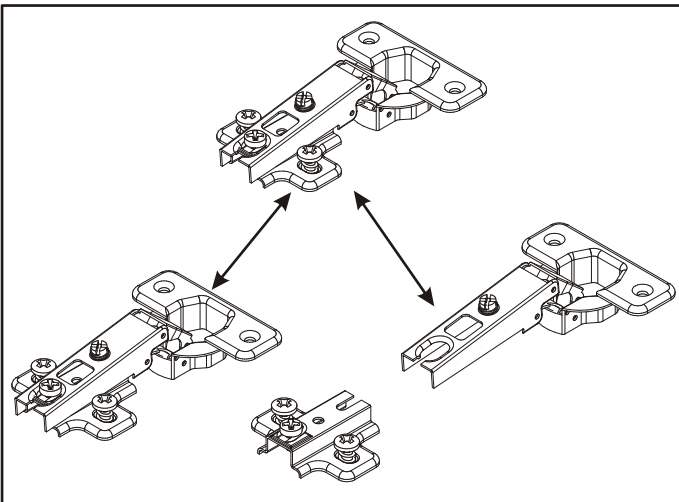
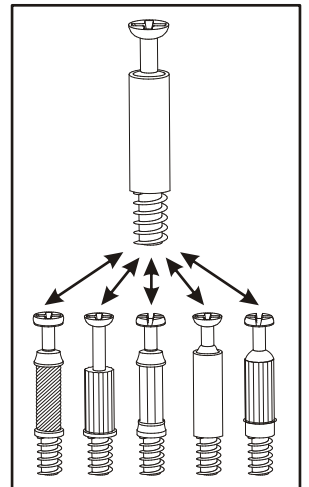
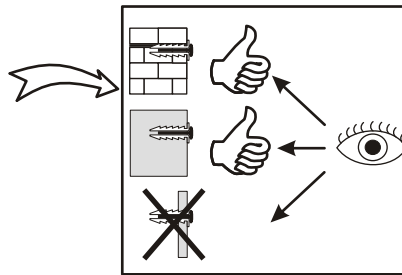
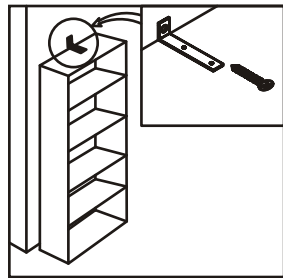
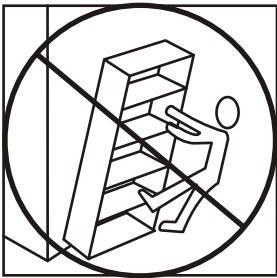
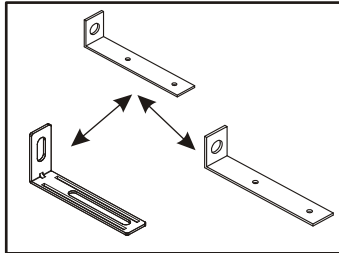
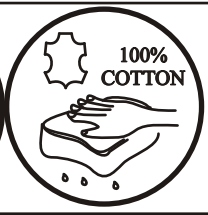
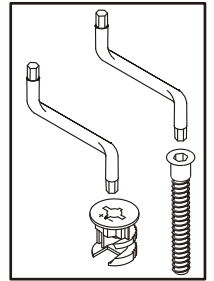
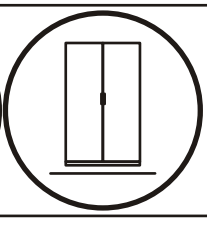
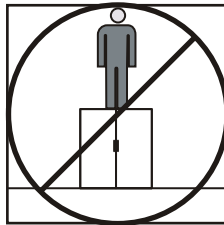
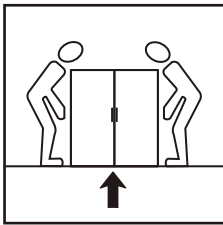
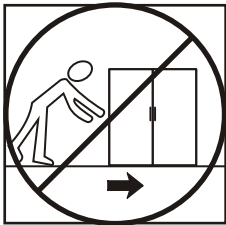
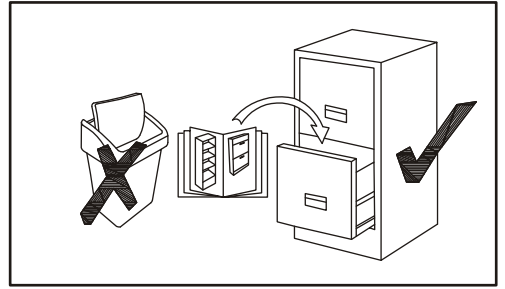
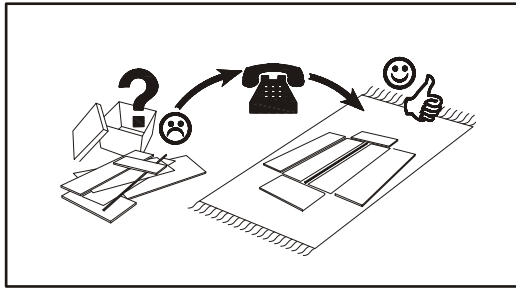
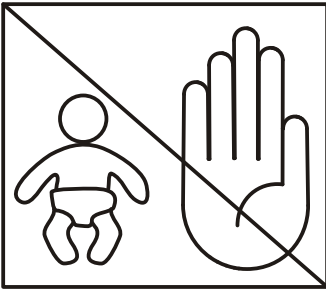
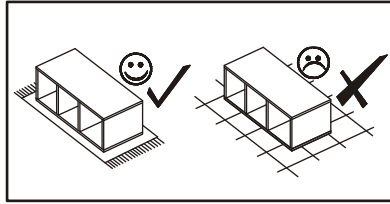
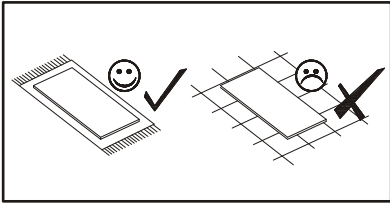



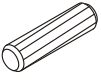

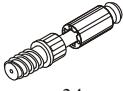
| NO | DIM  |      | COL.-NO | QTY |
|----|------|------|---------|-----|
| 1  | 1128 | 283  | 22 2/3  | 1   |
| 2  | 1128 | 283  | 22 2/3  | 1   |
| 3  | 800  | 284  | 22 2/3  | 1   |
| 4  | 376  | 253  | 16 2/3  | 1   |
| 5  | 376  | 253  | 16 2/3  | 2   |
| 6  | 379  | 250  | 16 2/3  | 1   |
| 7  | 388  | 1140 | 3 2/3   | 1   |
| 8  | 421  | 284  | 22 2/3  | 1   |

SILK 2 TYP 32 28\_SK2

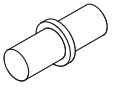

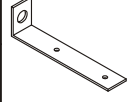
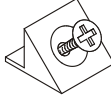

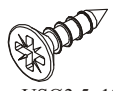
SILK 2 TYP 32 28\_SK2

|  |   |  |  |   |   |
|--|---|--|--|---|---|
| A1<br>x14<br><br>ø8x36    | B11<br>x8<br><br>Ø7x50     | G4<br>x8<br>        | B4<br>x8<br><br>34 | B5<br>x4<br><br>ø15x12 | B16<br>x4<br><br>Ø15x16    |
| G5<br>x8<br>              | G7<br>x8<br>               | KR1<br>x1<br><br>Ø8 | L1<br>x1<br>       | S1<br>x8<br>           | ST7<br>x6<br><br>Ø50, h=25 |
| UP11<br>x6<br><br>UPØ4x20 | D10<br>x2<br><br>USØ3,5x13 | G2<br>x1<br>        |  |   |   |

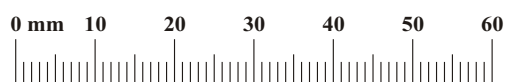

1

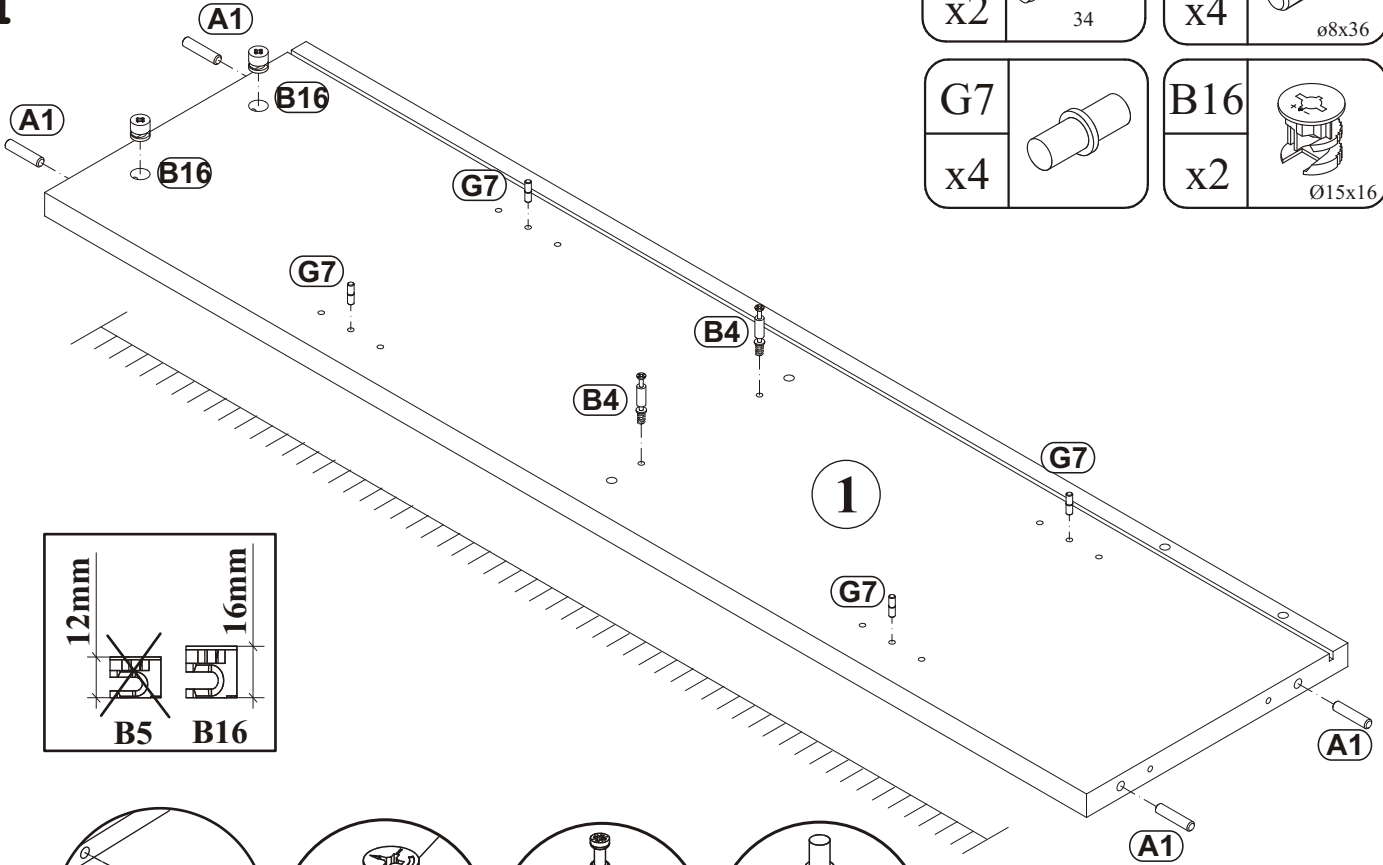

|    |    |    |       |
|----|----|----|-------|
| B4 |    | A1 |       |
| x2 | 34 | x4 | ø8x36 |

|    |  |     |        |
|----|--|-----|--------|
| G7 |  | B16 |        |
| x4 |  | x2  | Ø15x16 |

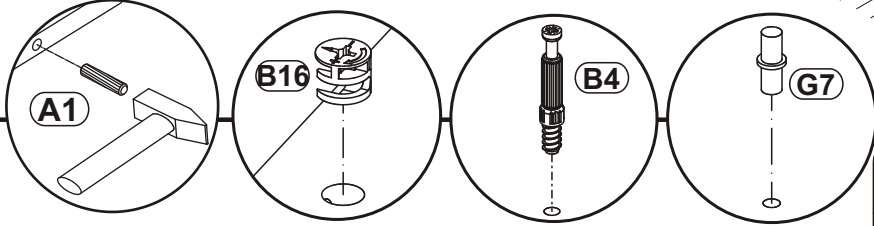
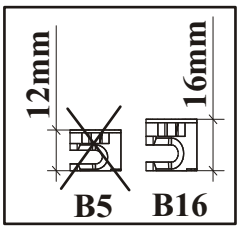

2

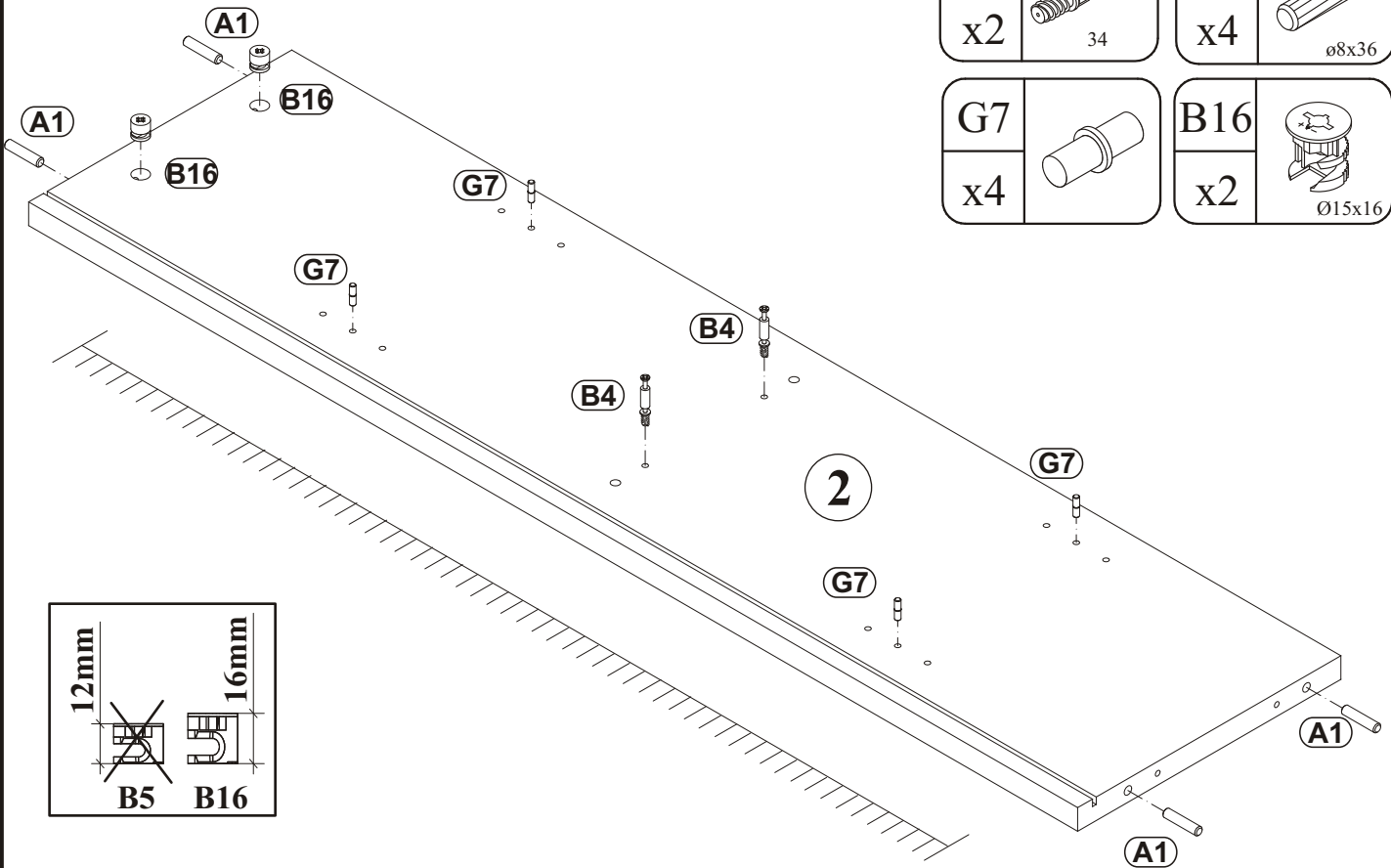

|    |    |    |       |
|----|----|----|-------|
| B4 |    | A1 |       |
| x2 | 34 | x4 | ø8x36 |

|    |  |     |        |
|----|--|-----|--------|
| G7 |  | B16 |        |
| x4 |  | x2  | Ø15x16 |

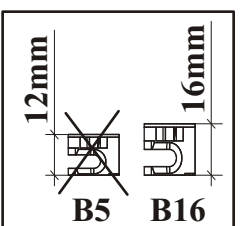

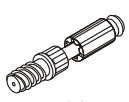

|    |   |
|----|---|
| B4 |  |
| x4 | 34  |

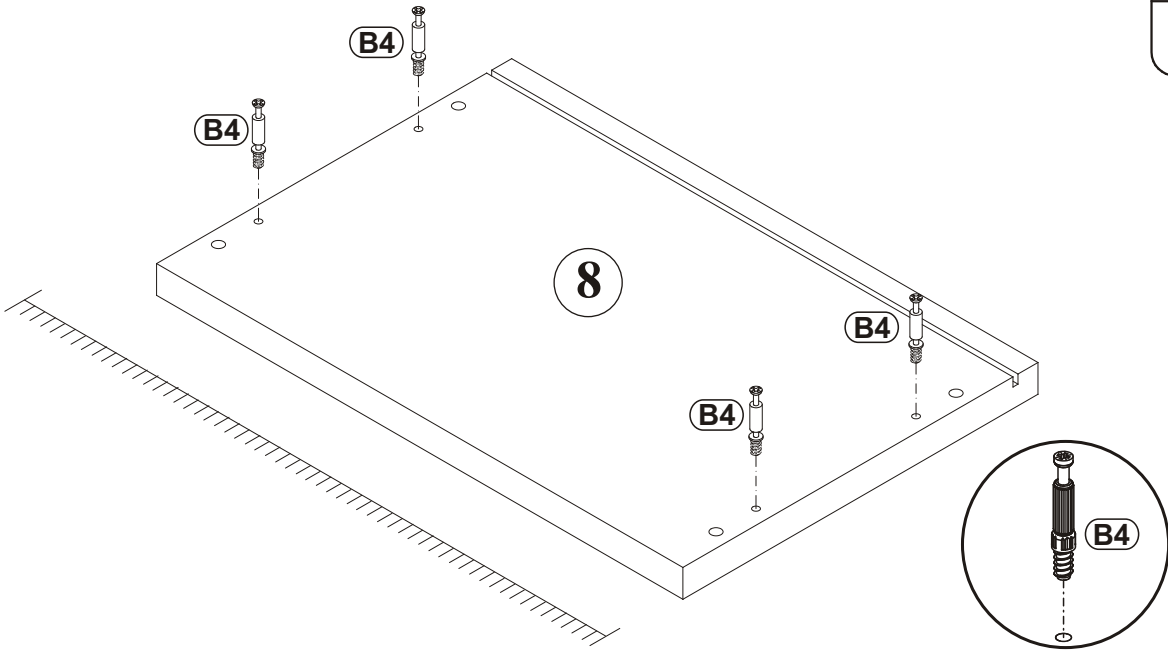
3

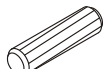

4

|    |   |
|----|---|
| A1 |  |
| x6 | ø8x36   |

|    |   |
|----|---|
| B5 |  |
| x4 | ø15x12  |

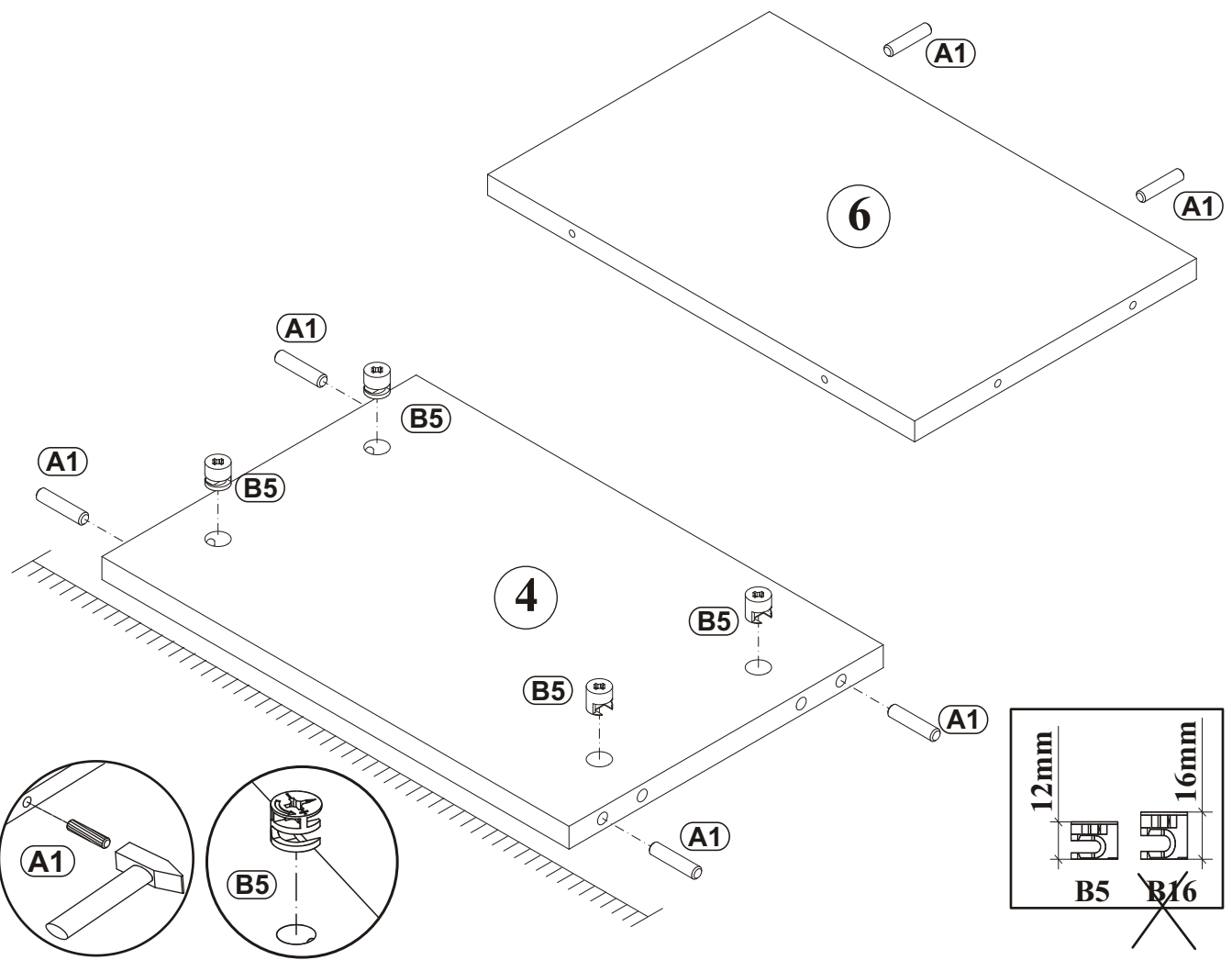



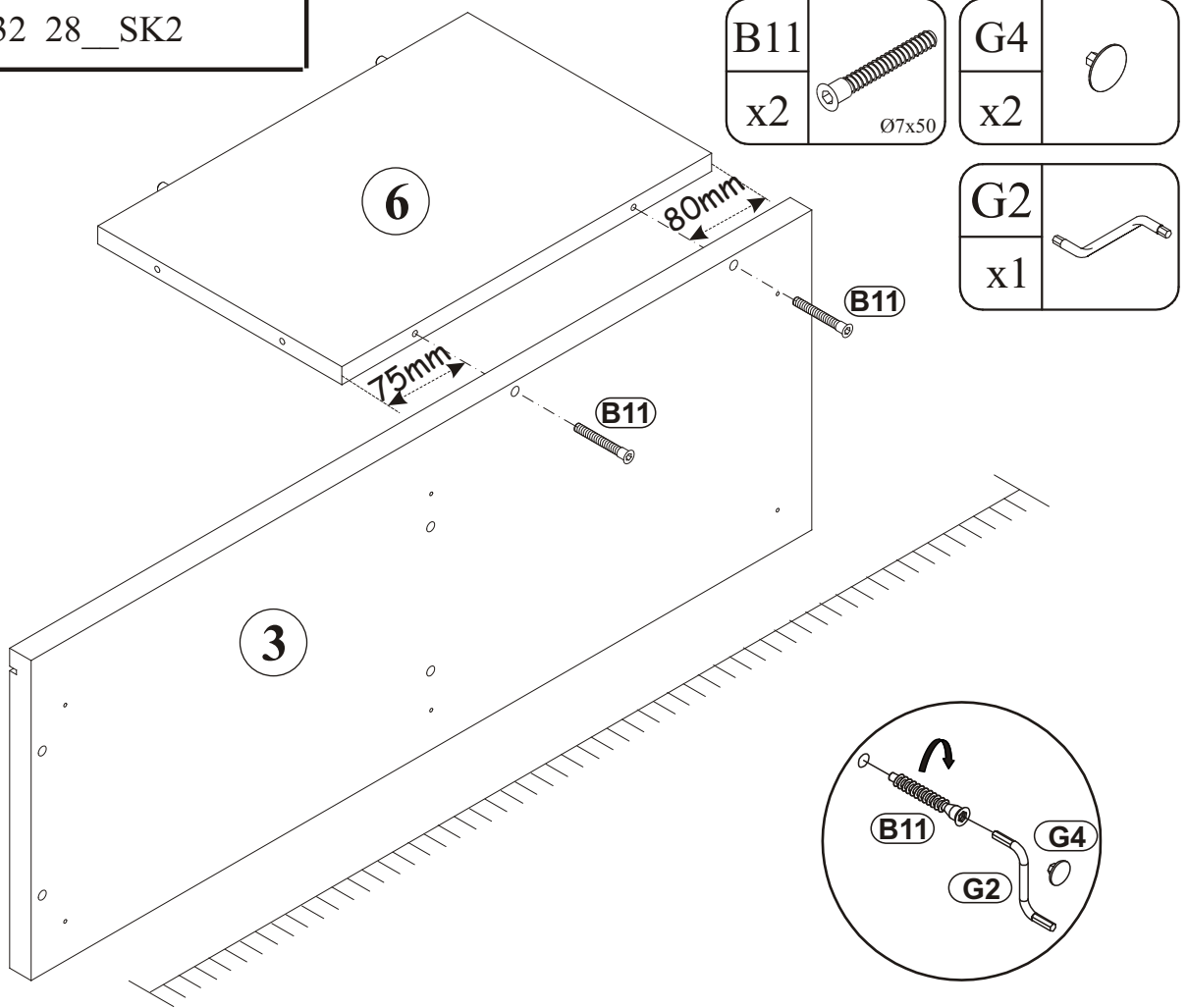

5



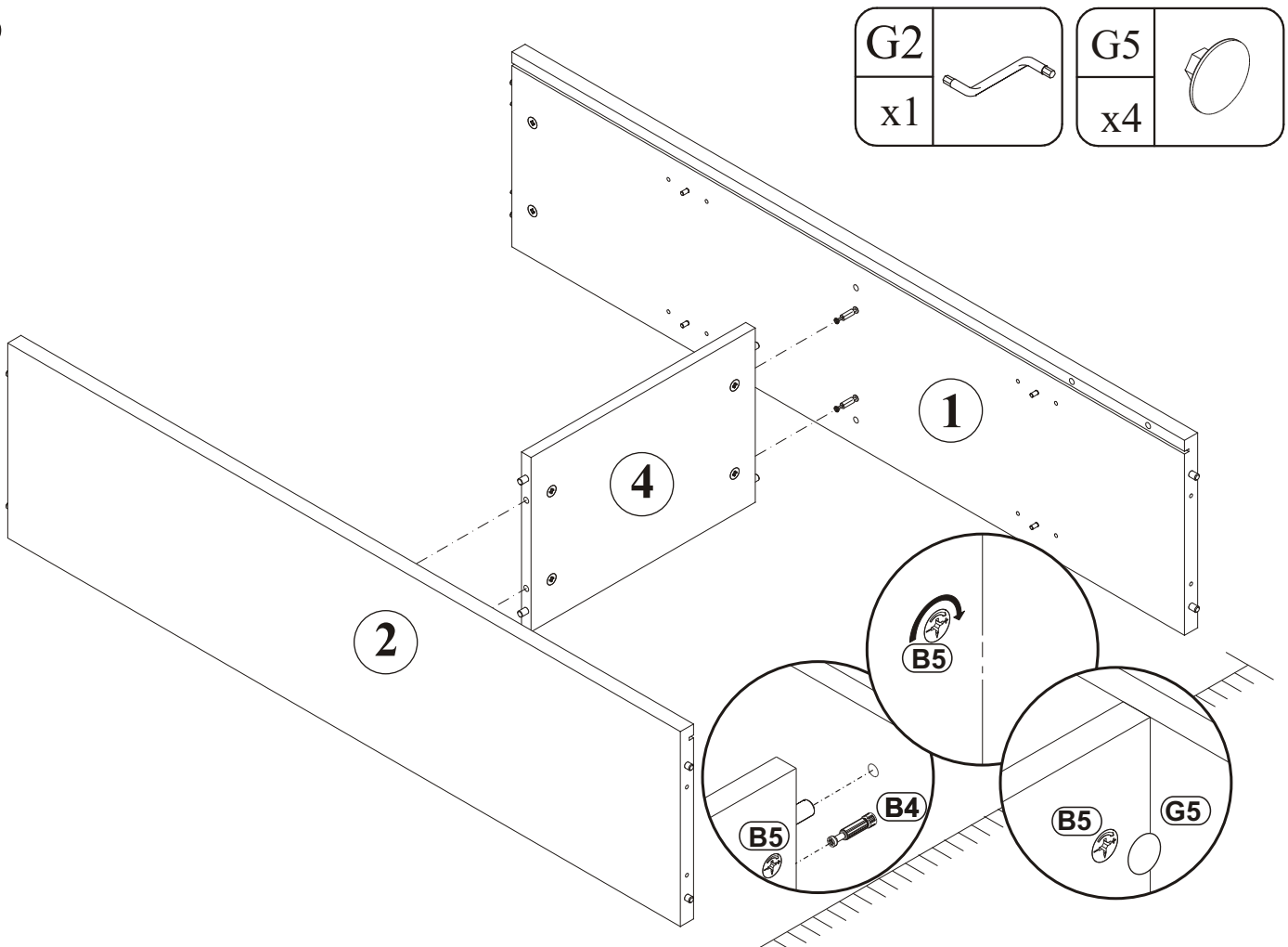

6



7

|     |   |
|-----|---|
| B11 |  |
| x4  | Ø7x50   |

|    |   |
|----|---|
| G4 |  |
| x4 |   |

|    |   |
|----|---|
| G2 |  |
| x1 |   |

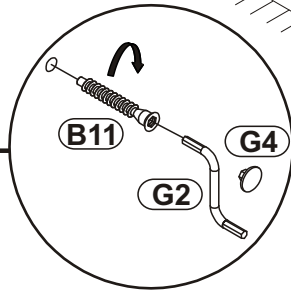
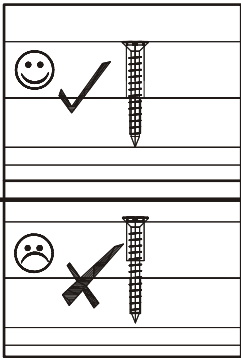
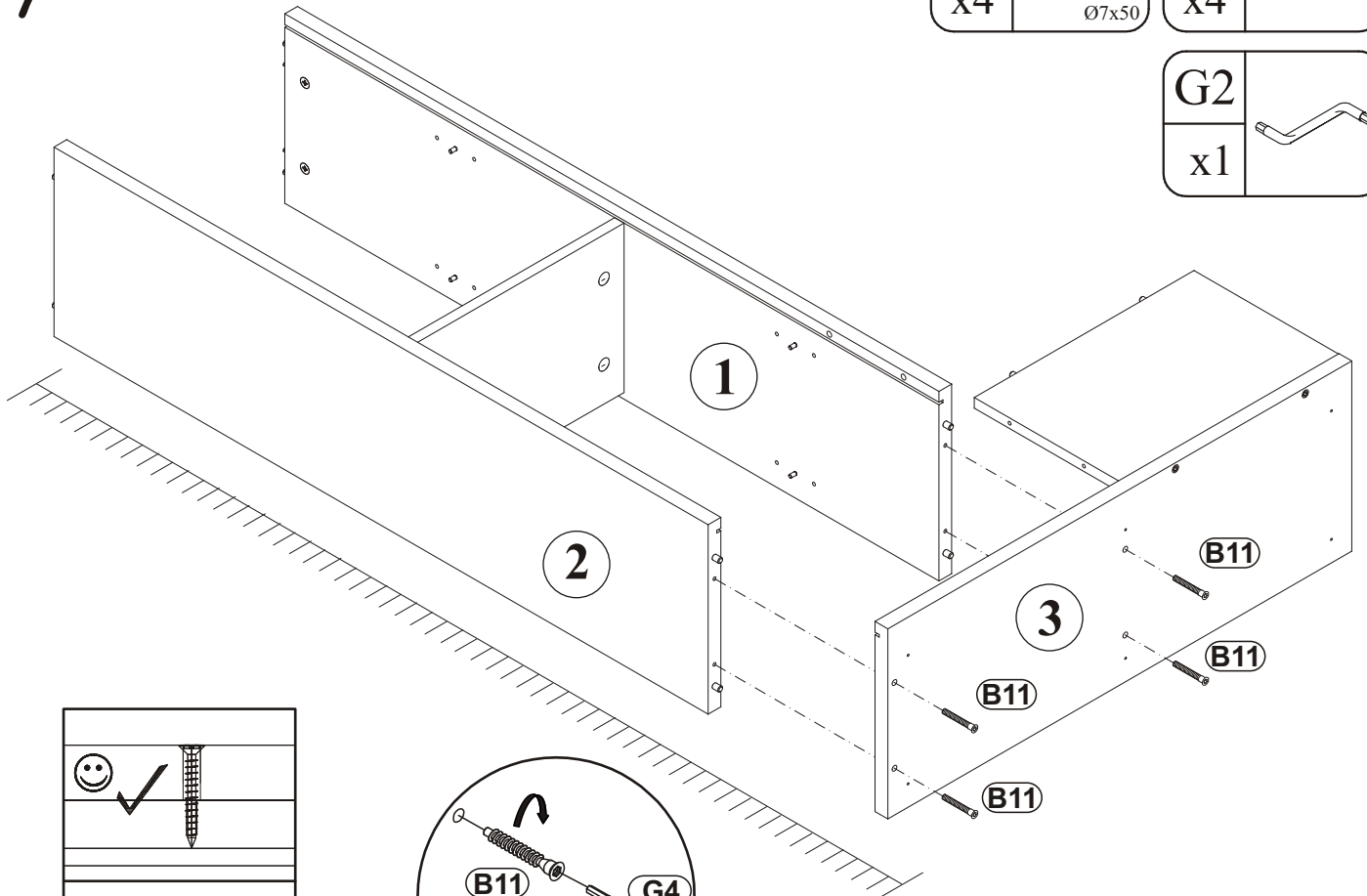

8

|     |   |
|-----|---|
| B11 |  |
| x2  | Ø7x50   |

|    |   |
|----|---|
| G4 |  |
| x2 |   |

|    |   |
|----|---|
| G2 |  |
| x1 |   |

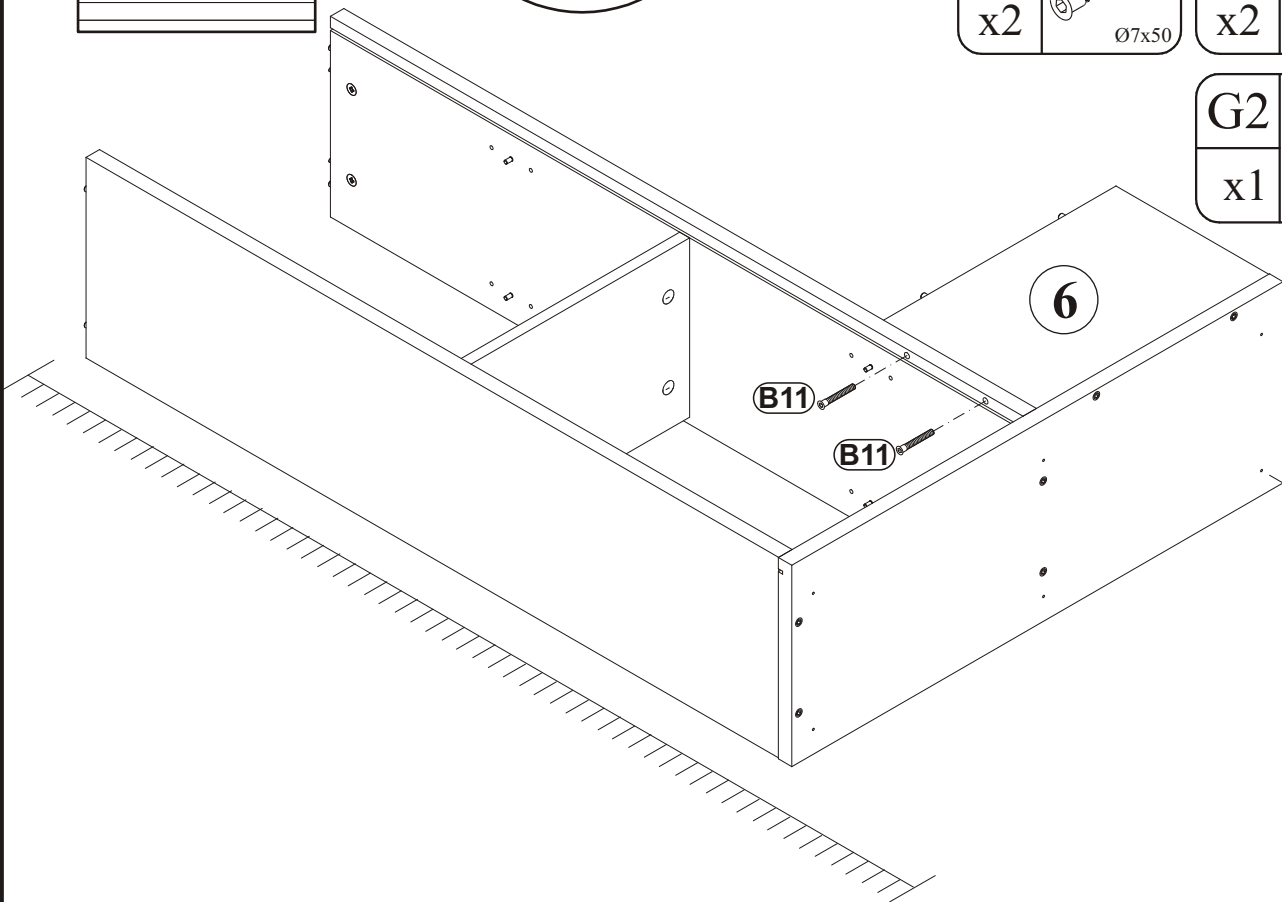

9



90°



180°

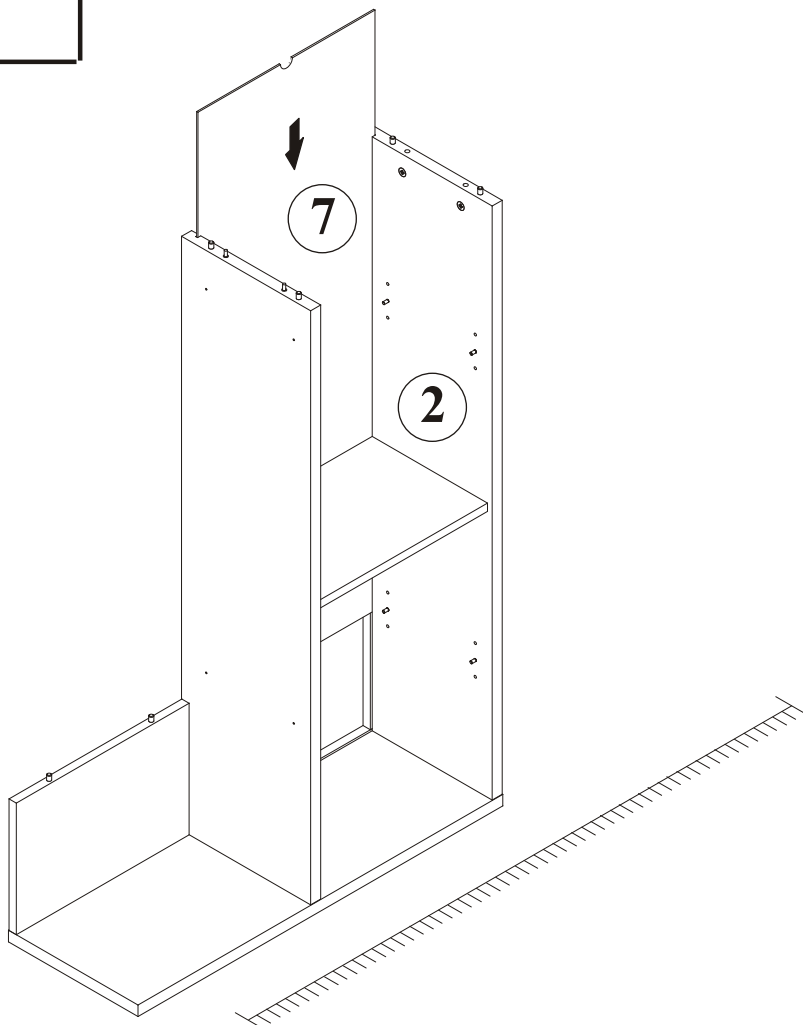

10

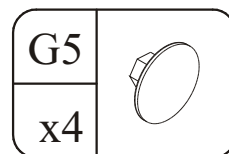
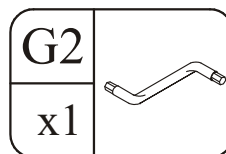
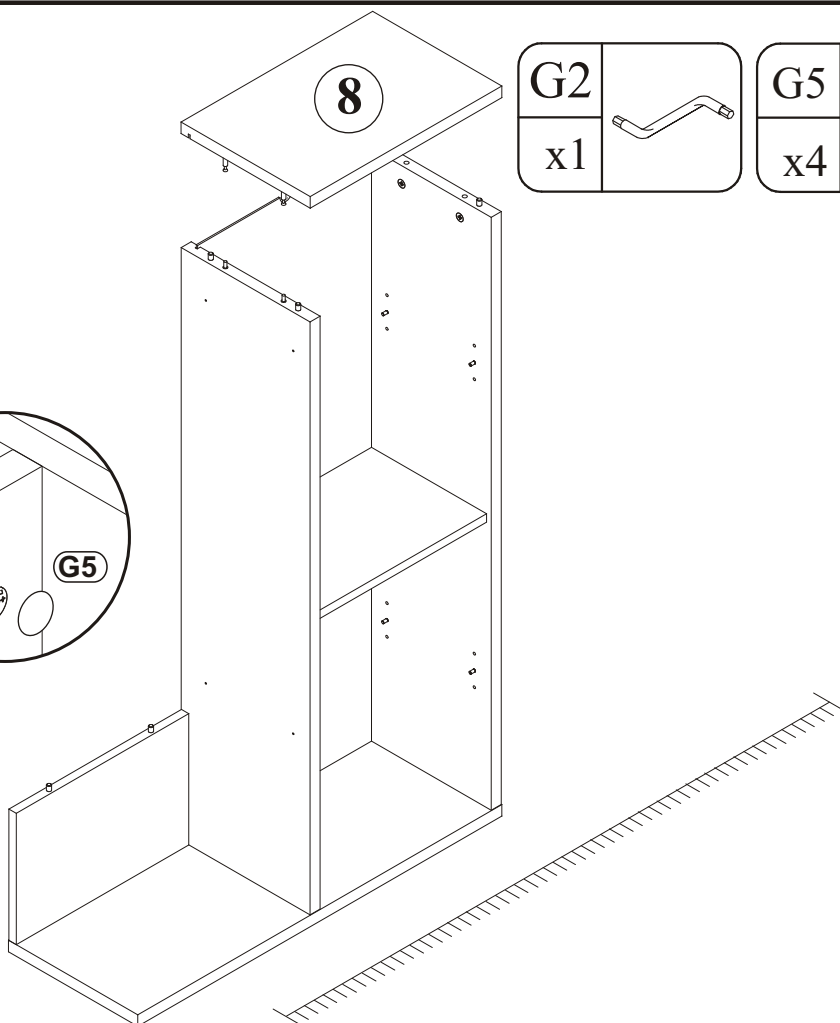
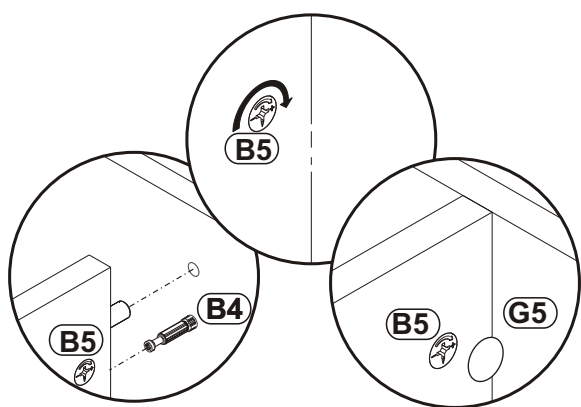

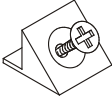
|    |   |
|----|---|
| S1 |  |
| x8 |   |

11

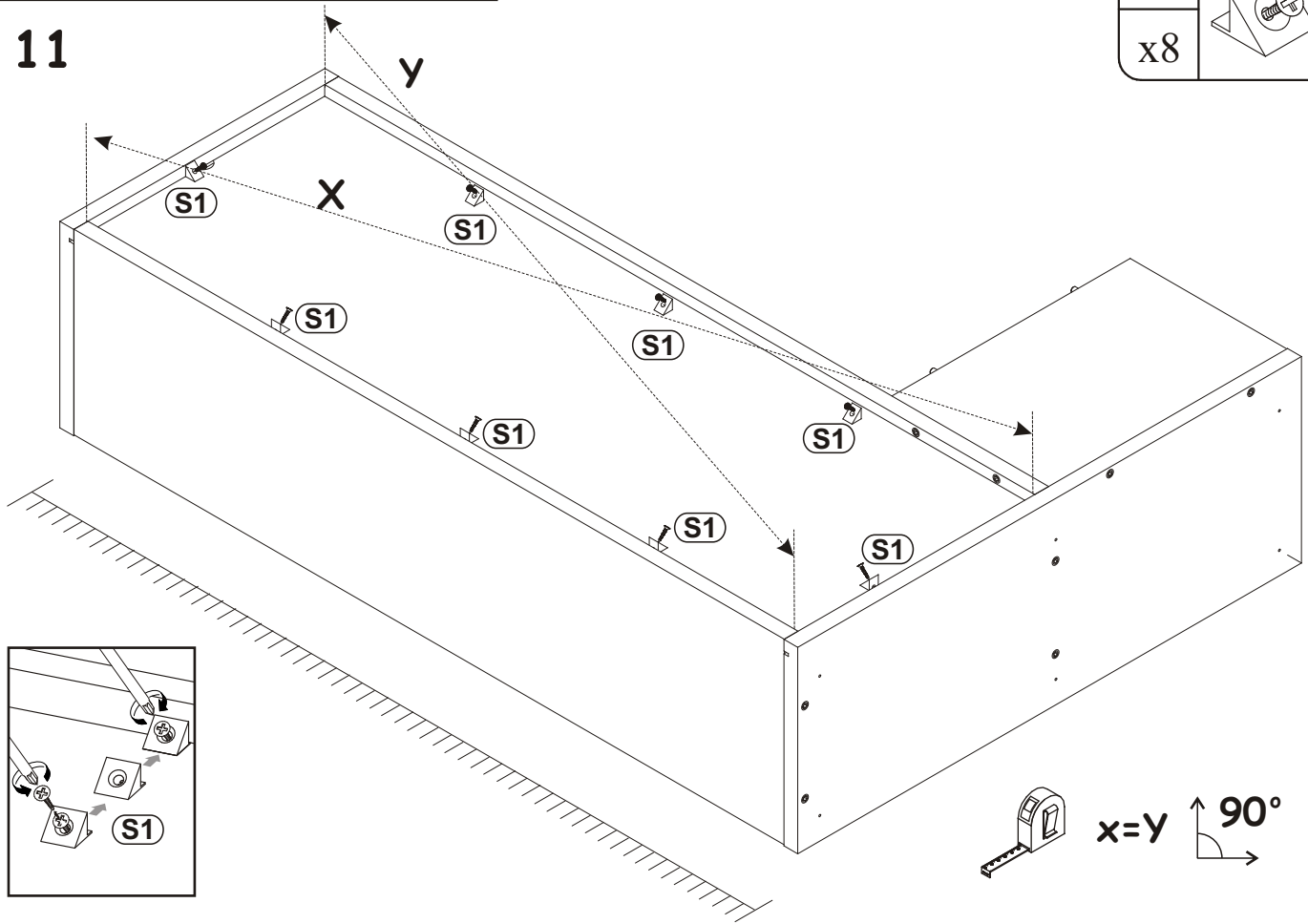

  $x=y$   $90^\circ$

12

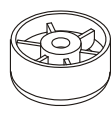
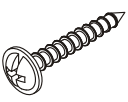
|     |   |      |   |
|-----|---|------|---|
| ST7 |  | UP11 |  |
| x6  | Ø50, h=25   | x6   | UPØ4X20   |

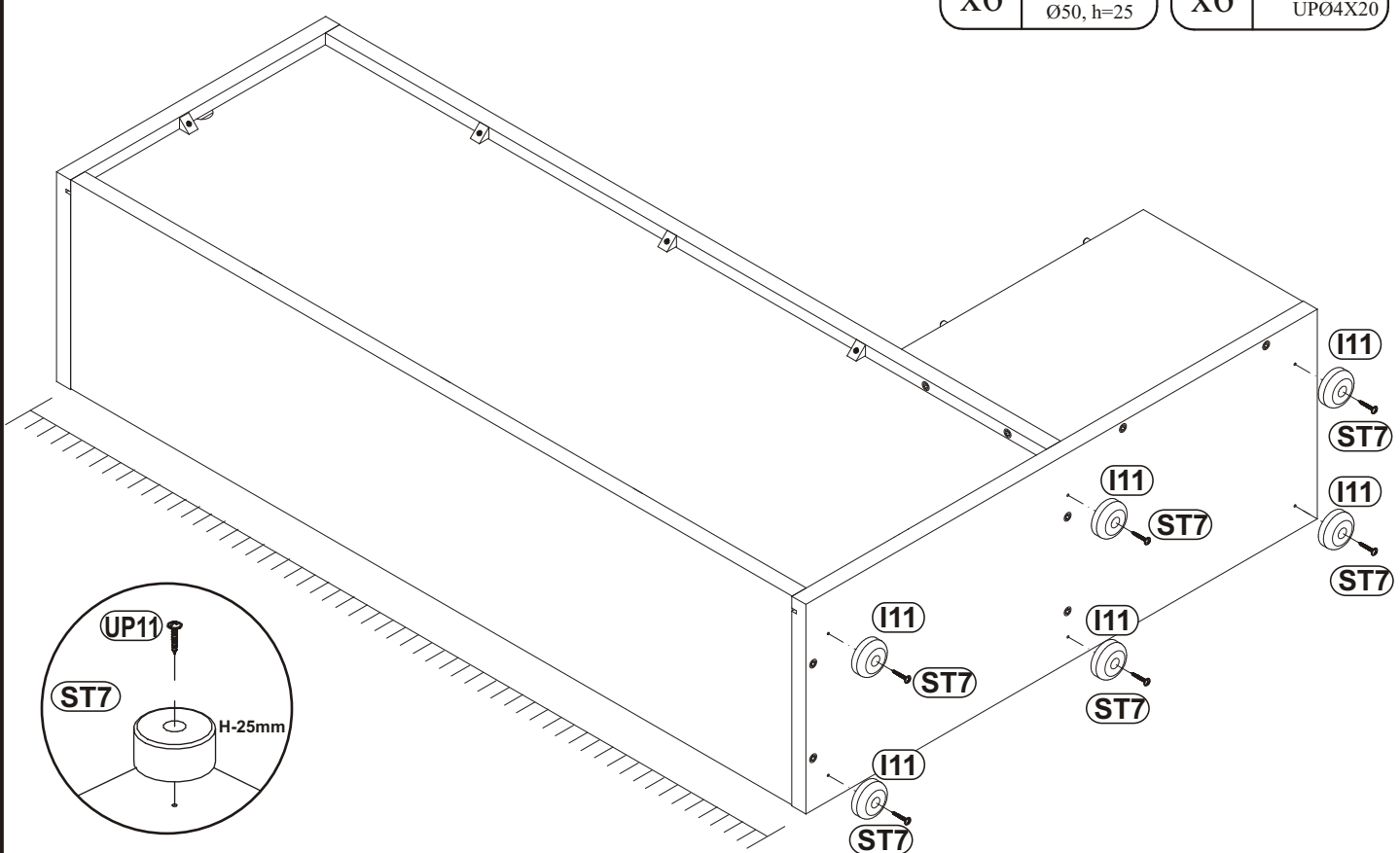

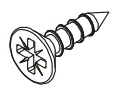
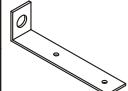
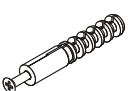
|     |  |    |   |     |   |
|-----|--|----|---|-----|---|
| D10 |  | L1 |  | KR1 |  |
| x2  | USØ3,5x13  | x1 |   | x1  | Ø8  |

13

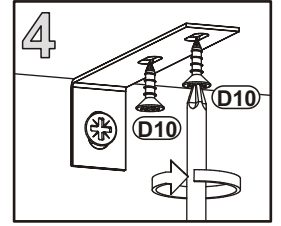
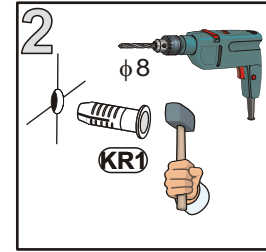
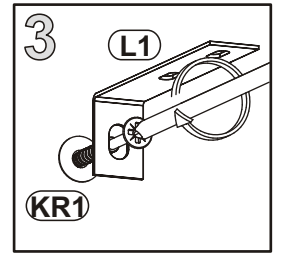
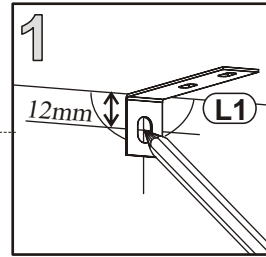
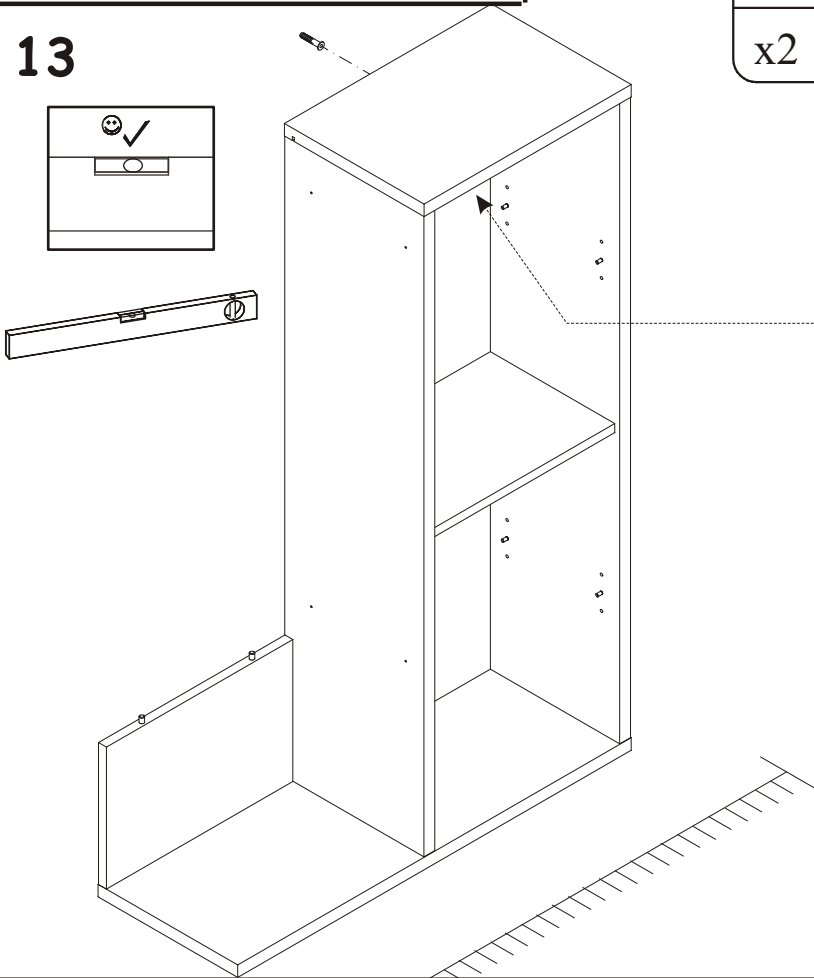

14

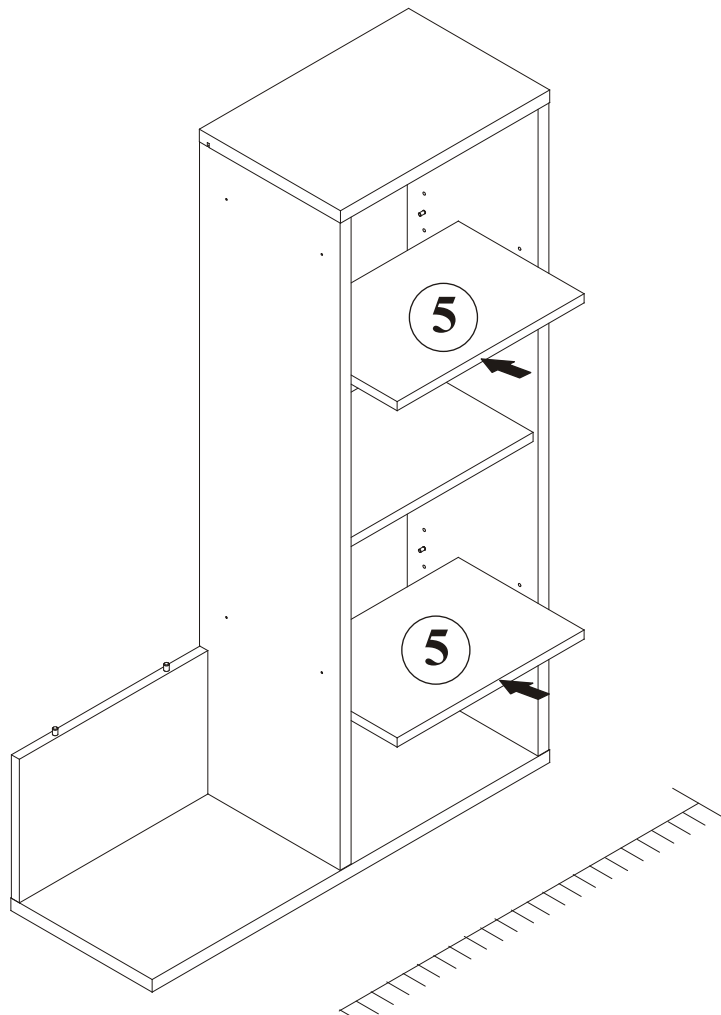

# SILK 2 TYP 60 28\_SK2

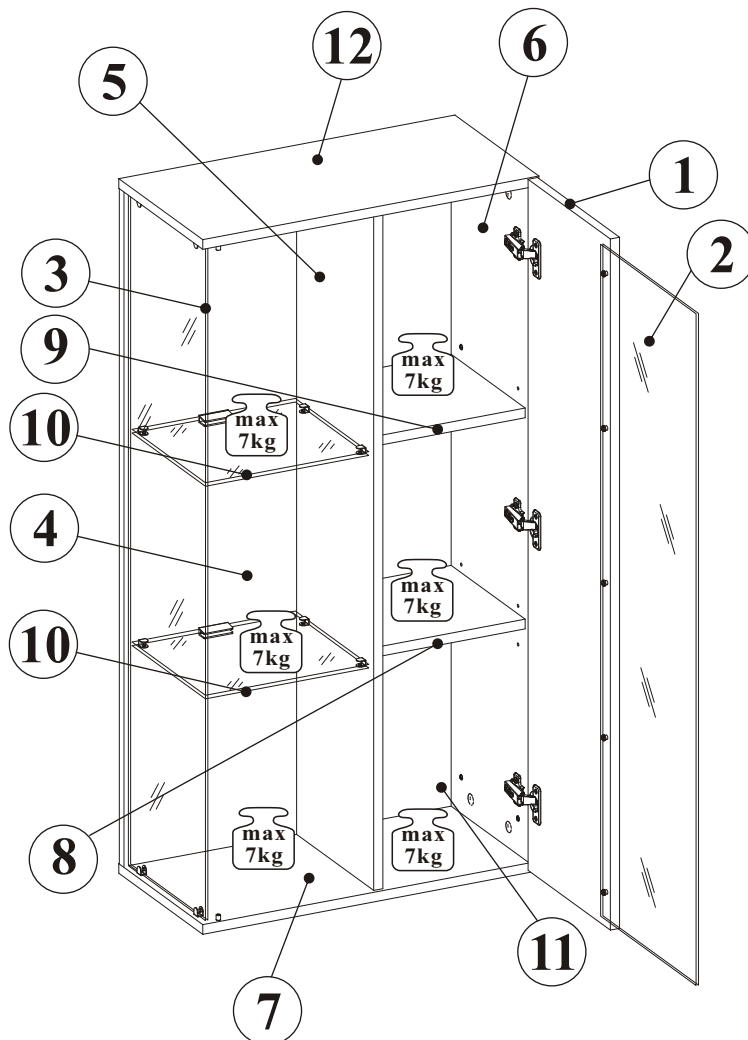
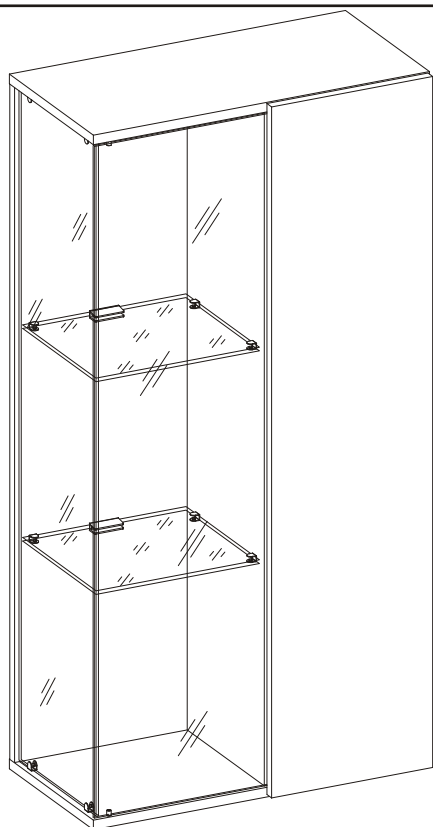
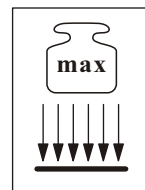
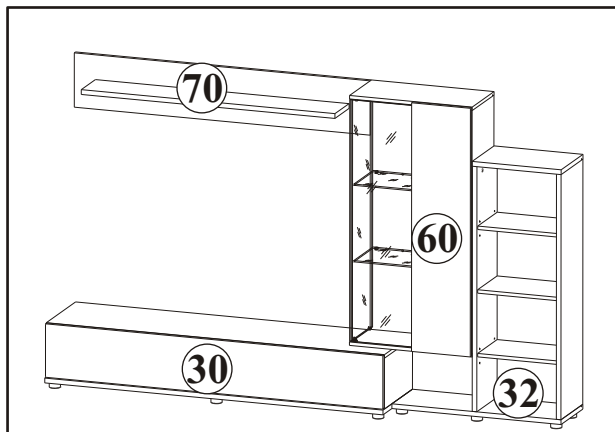

| NO | DIM  |      | COL.-NO | QTY |
|----|------|------|---------|-----|
| 1  | 278  | 1144 | 16 3/3  | 1   |
| 2  | 1112 | 323  | 4 3/3   | 1   |
| 3  | 1112 | 261  | 4 3/3   | 1   |
| 4  | 298  | 1118 | 16 3/3  | 1   |
| 5  | 277  | 1118 | 16 3/3  | 1   |
| 6  | 1118 | 284  | 16 3/3  | 1   |
| 7  | 580  | 284  | 16 3/3  | 1   |
| 8  | 249  | 250  | 16 3/3  | 1   |
| 9  | 249  | 250  | 16 3/3  | 1   |
| 10 | 282  | 248  | 6 3/3   | 2   |
| 11 | 261  | 1130 | 3 3/3   | 1   |
| 12 | 580  | 284  | 16 3/3  | 1   |

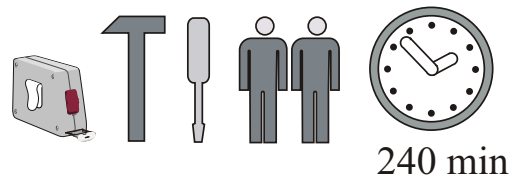



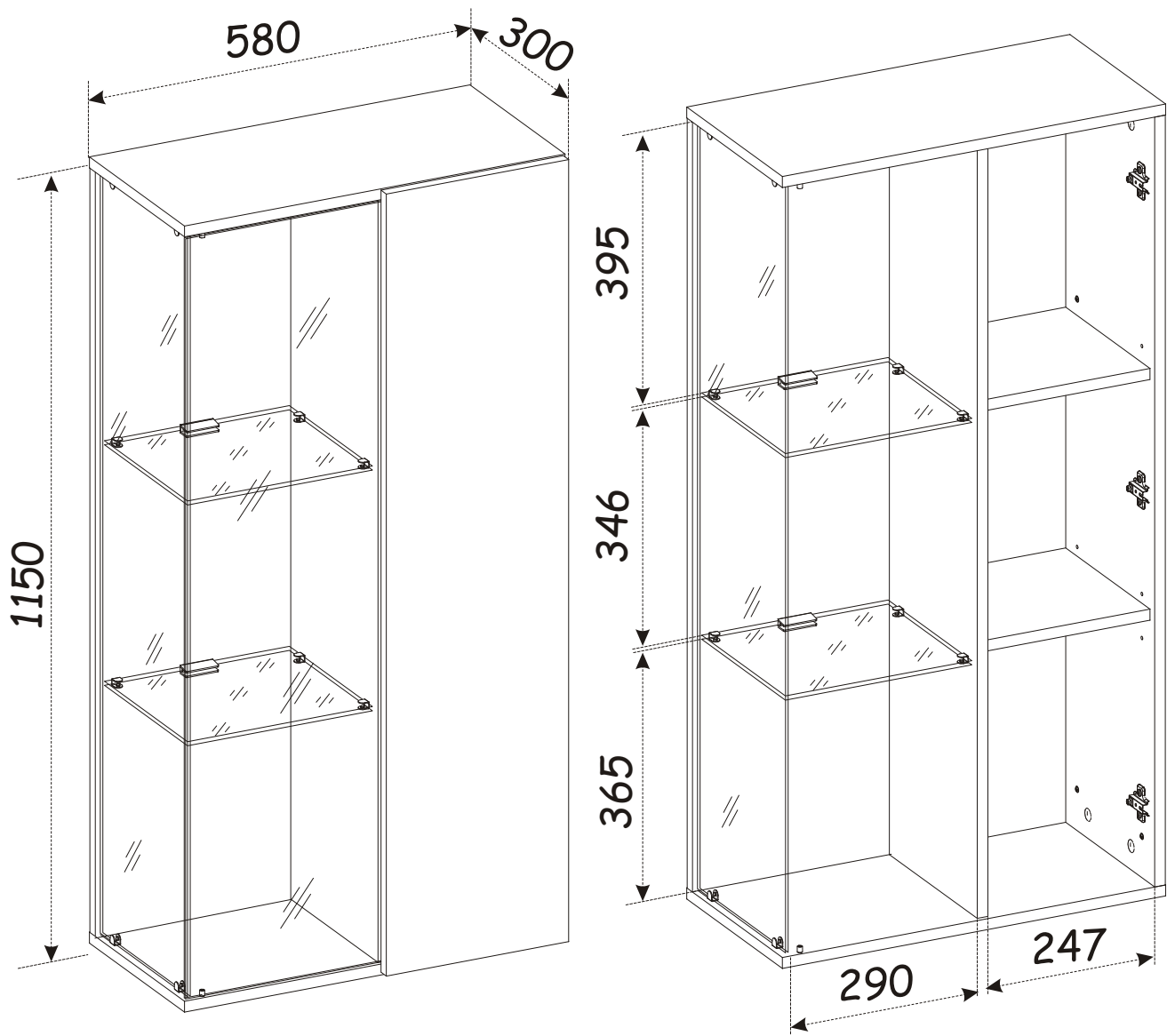

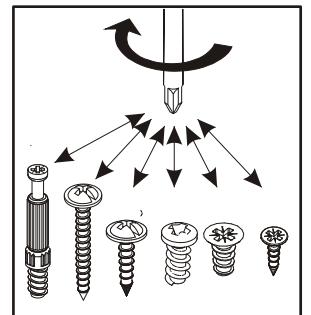
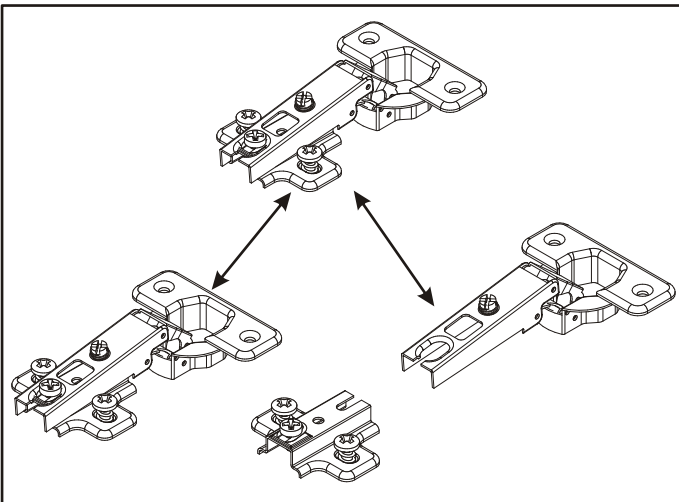
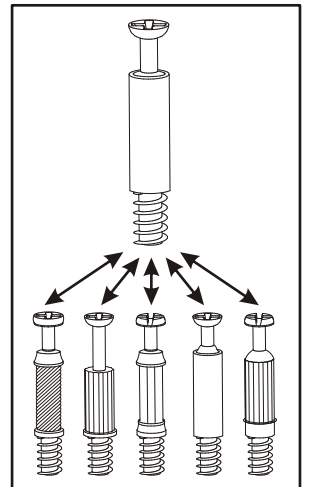
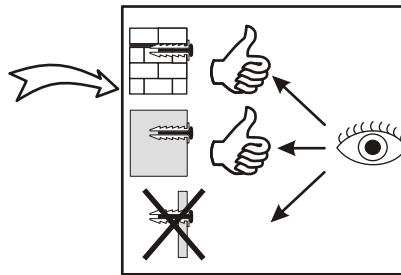
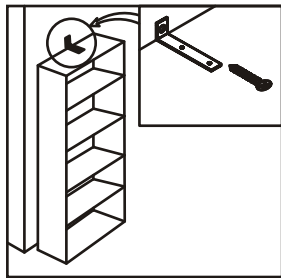
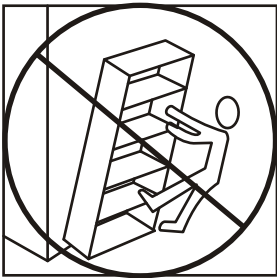
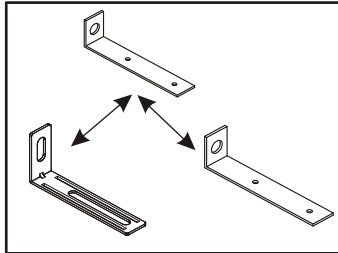
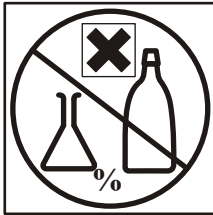
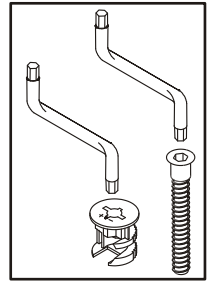
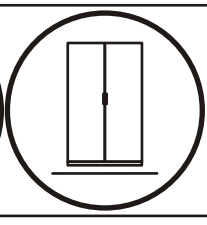
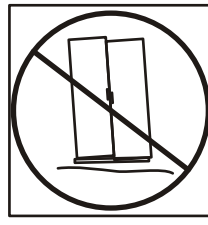
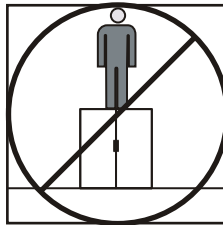
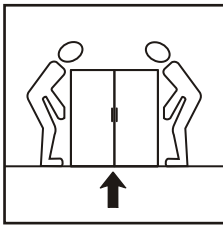
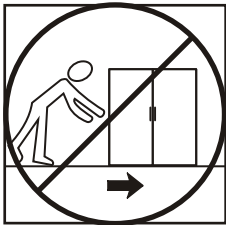
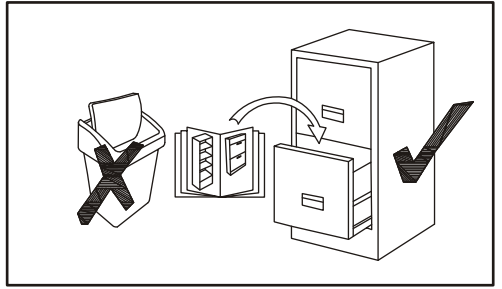
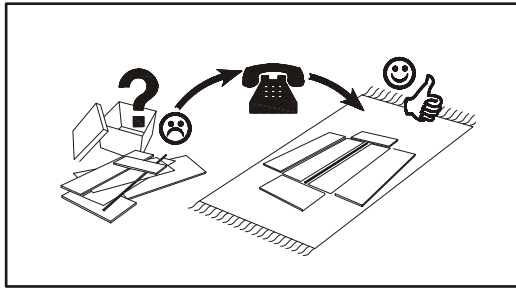
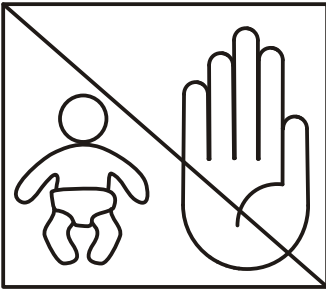
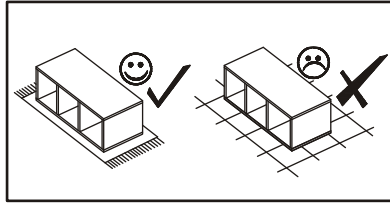
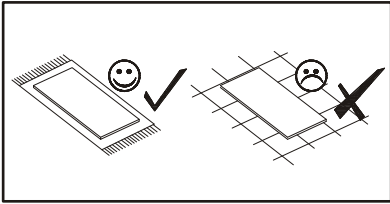



# SILK 2 TYP 60 28\_SK2

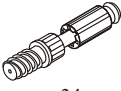

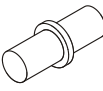
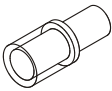
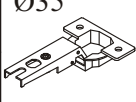
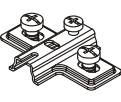
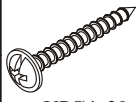
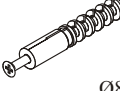
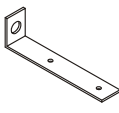
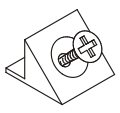

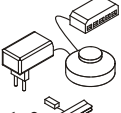

SILK 2 TYP 60 28\_\_SK2

|  |   |   |  |  |  |
|--|---|---|--|--|--|
| A1<br>x20<br><br>ø8x36      | B4<br>x20<br><br>34  | B5<br>x20<br><br>ø15x12  | G5<br>x20<br>              | G7<br>x4<br>              | G20<br>x2<br> |
| E21<br>x3<br><br>Ø35<br>H=0 | E2<br>x3<br><br>H=0  | UP6<br>x4<br><br>UPØ4x30 | KR1<br>x1<br><br>Ø8        | L1<br>x1<br>              | S1<br>x8<br>  |
| G30<br>x10<br>              | UL1<br>x2<br><br>1x2 | P2<br>x5<br>             | D10<br>x8<br><br>USØ3,5x13 | UP13<br>x5<br><br>UPØ3x16 | G2<br>x1<br>  |

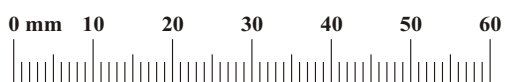

1

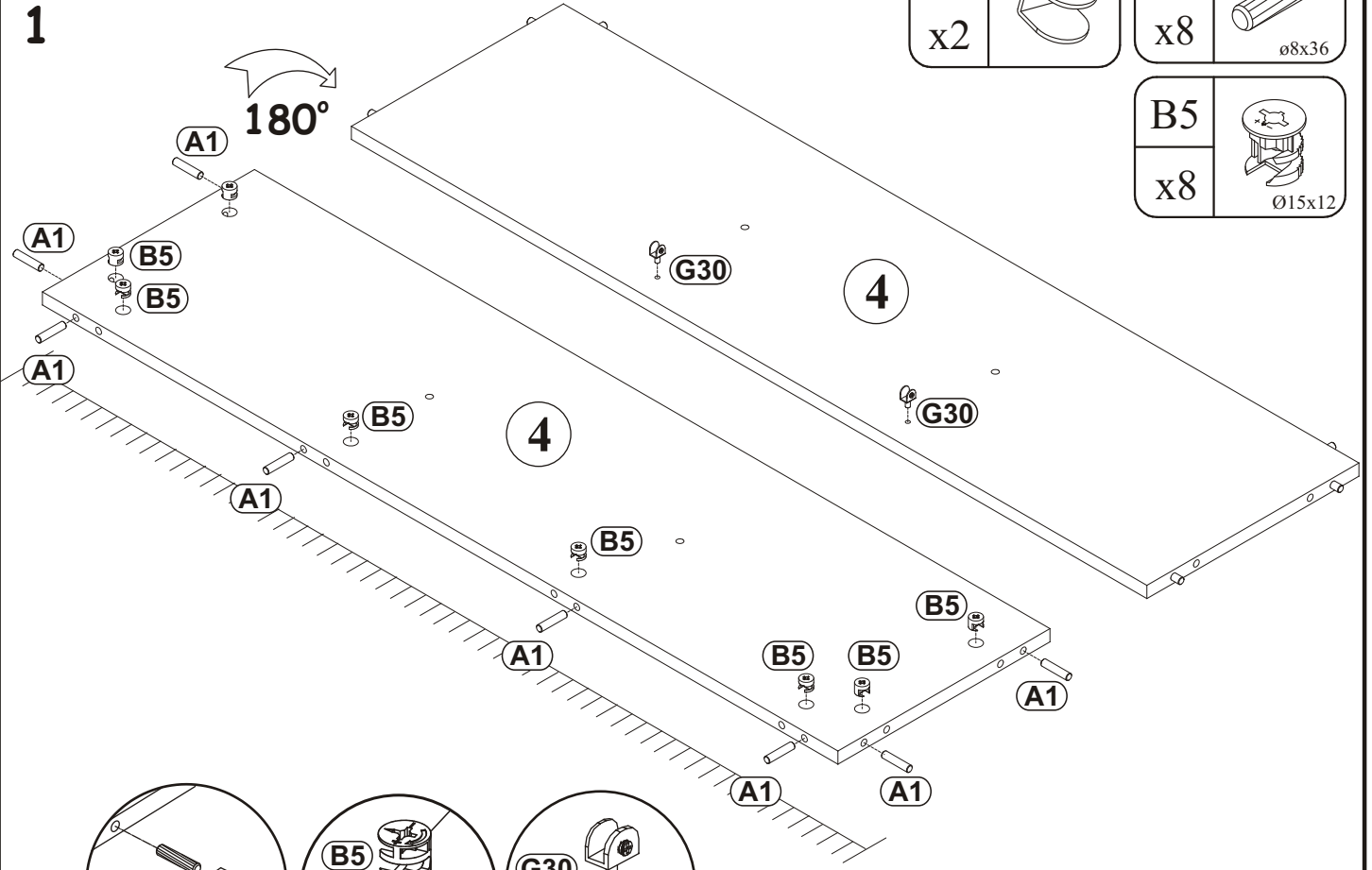

|     |  |
|-----|--|
| G30 |  |
| x2  |  |

|    |       |
|----|-------|
| A1 |       |
| x8 | ø8x36 |

|    |        |
|----|--------|
| B5 |        |
| x8 | Ø15x12 |

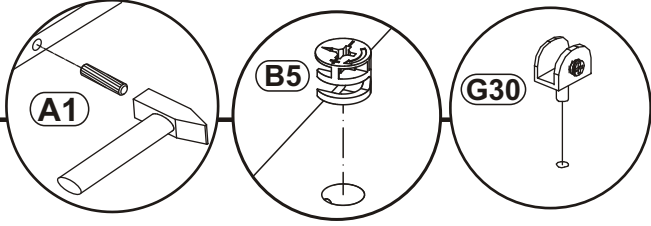

2

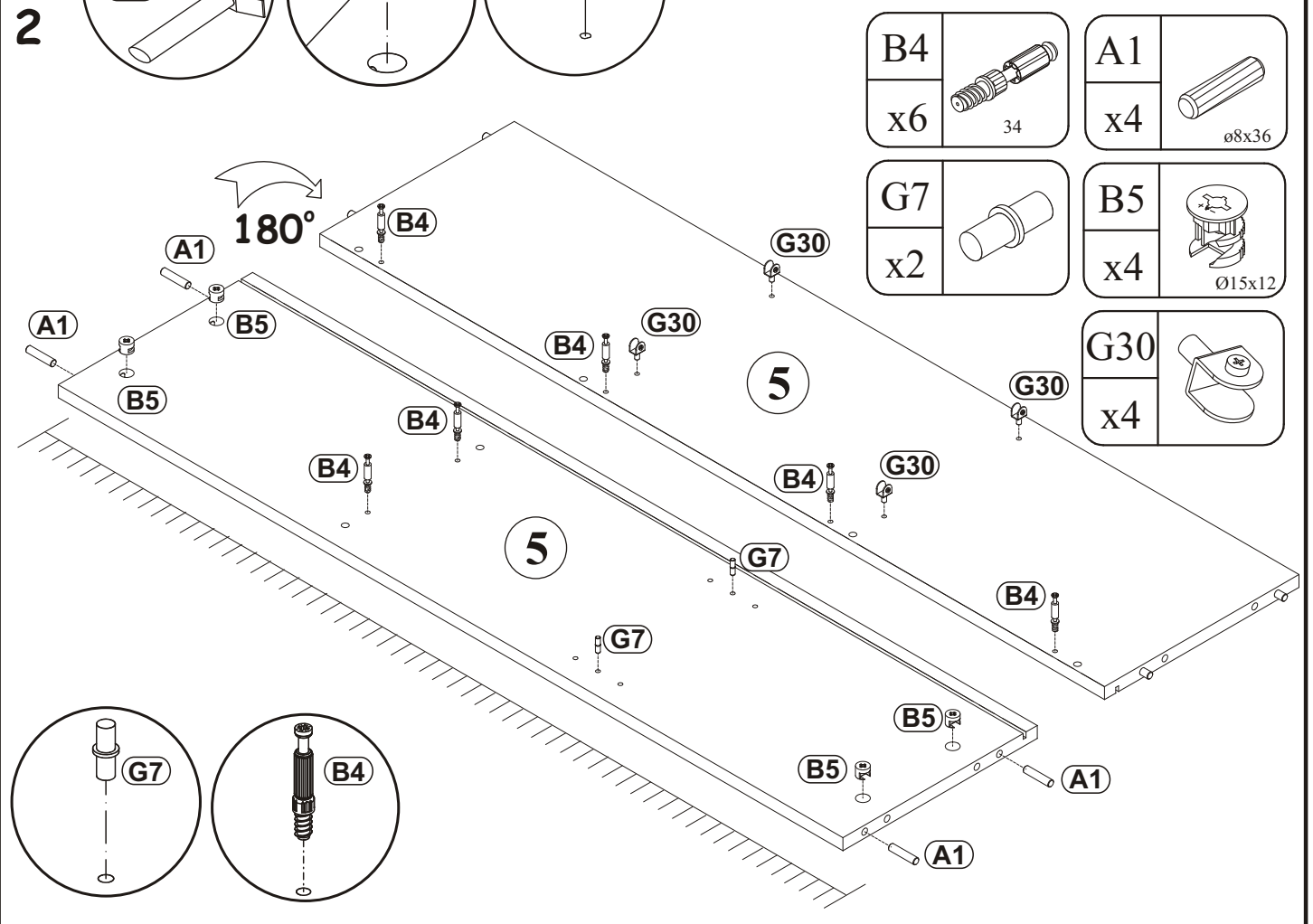

|    |    |
|----|----|
| B4 |    |
| x6 | 34 |

|    |       |
|----|-------|
| A1 |       |
| x4 | ø8x36 |

|    |  |
|----|--|
| G7 |  |
| x2 |  |

|    |        |
|----|--------|
| B5 |        |
| x4 | Ø15x12 |

|     |  |
|-----|--|
| G30 |  |
| x4  |  |

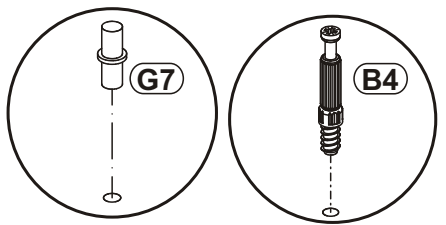

3

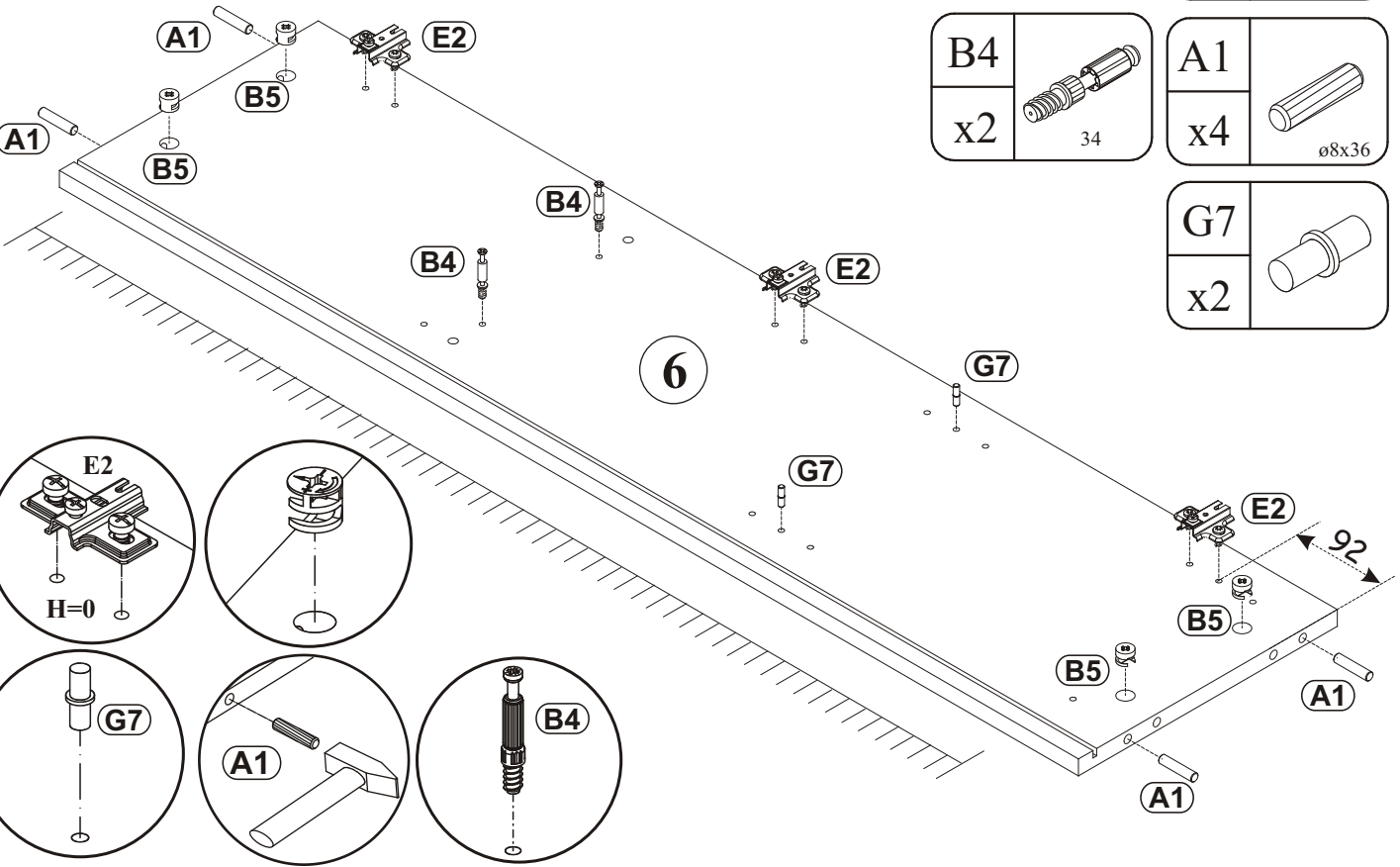

|    |     |
|----|-----|
| E2 |     |
| x3 | H=0 |

|    |        |
|----|--------|
| B5 |        |
| x4 | ø15x12 |

|    |    |
|----|----|
| B4 |    |
| x2 | 34 |

|    |       |
|----|-------|
| A1 |       |
| x4 | ø8x36 |

|    |  |
|----|--|
| G7 |  |
| x2 |  |

4

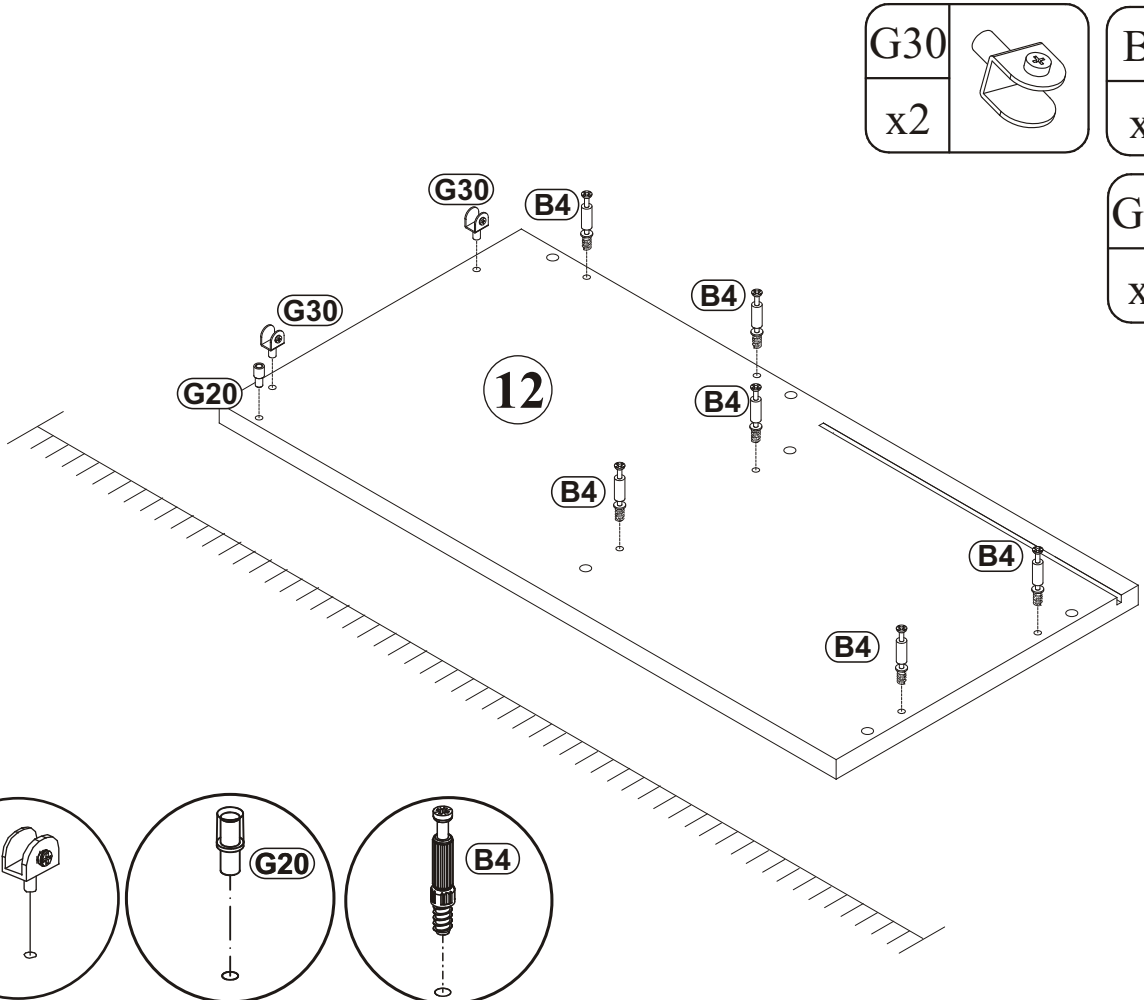

|     |  |
|-----|--|
| G30 |  |
| x2  |  |

|    |    |
|----|----|
| B4 |    |
| x6 | 34 |

|     |  |
|-----|--|
| G20 |  |
| x1  |  |

|     |  |
|-----|--|
| G30 |  |
|-----|--|

|     |  |
|-----|--|
| G20 |  |
|-----|--|

|    |  |
|----|--|
| B4 |  |
|----|--|

5

|     |   |
|-----|---|
| G30 |  |
| x2  |   |

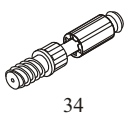
|    |   |
|----|---|
| B4 |  |
| x6 | 34  |

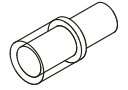
|     |   |
|-----|---|
| G20 |  |
| x1  |   |

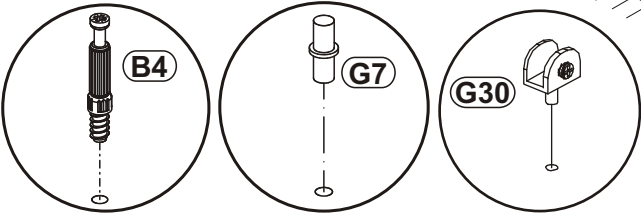
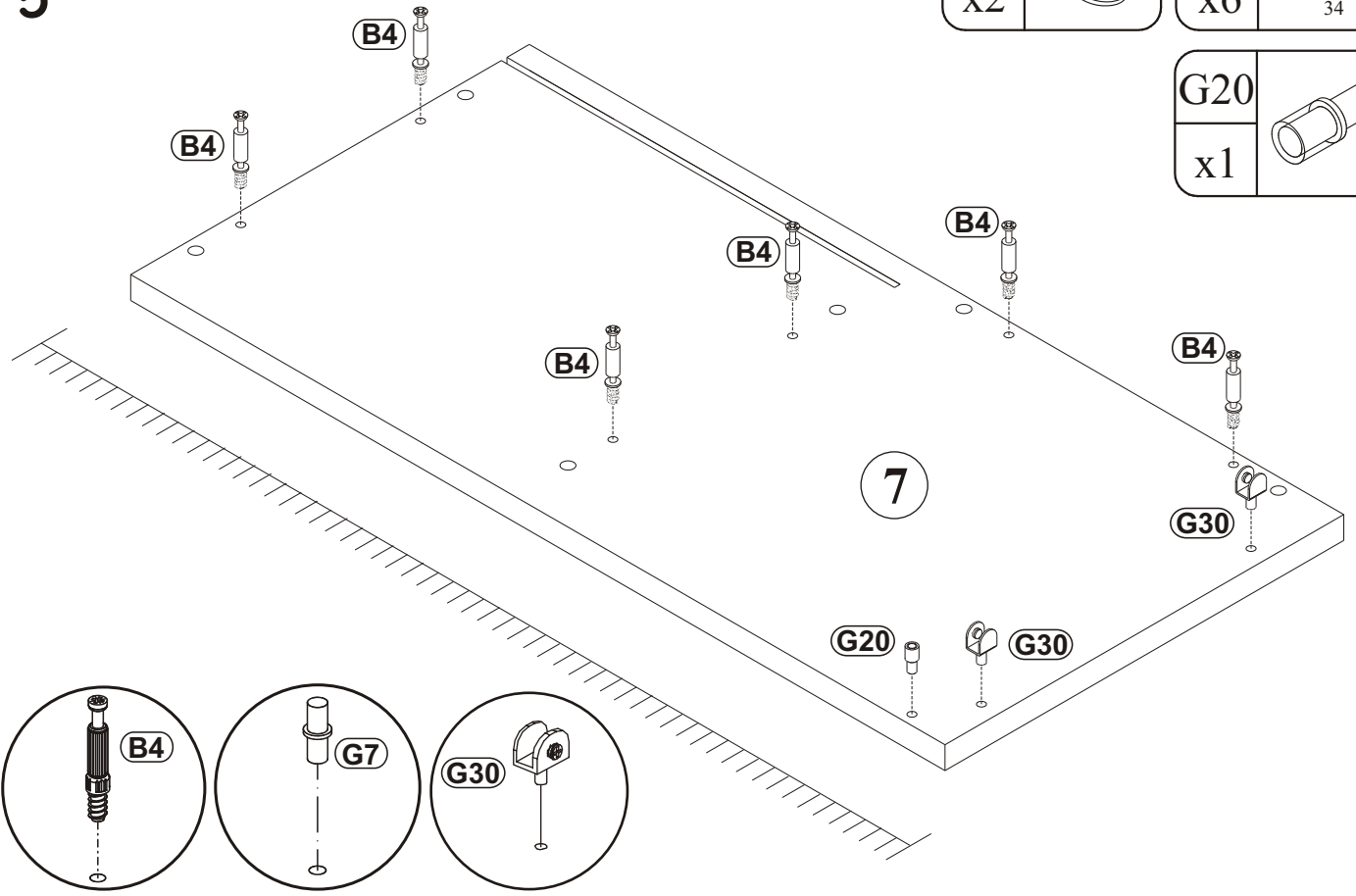



6

|    |   |
|----|---|
| A1 |  |
| x4 | ø8x36   |

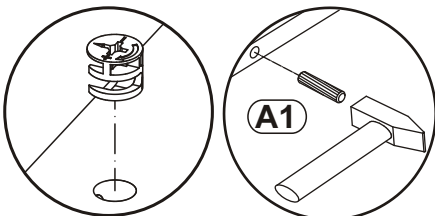
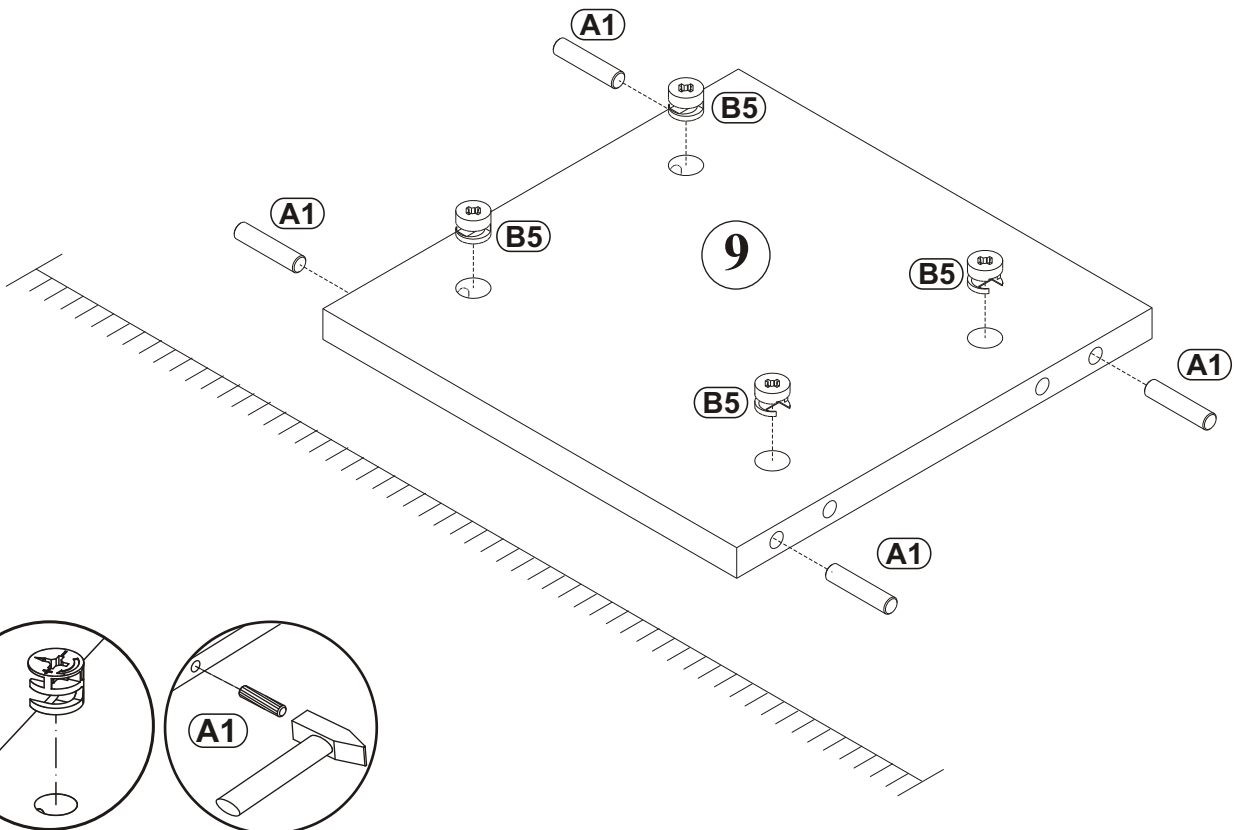
|    |   |
|----|---|
| B5 |  |
| x4 | ø15x12  |



|     |   |
|-----|---|
| UL1 |       |
| x2  | 1x2  |

7 x1

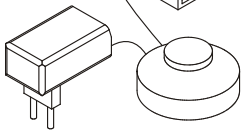

x2 UL1

UL1

10

x2

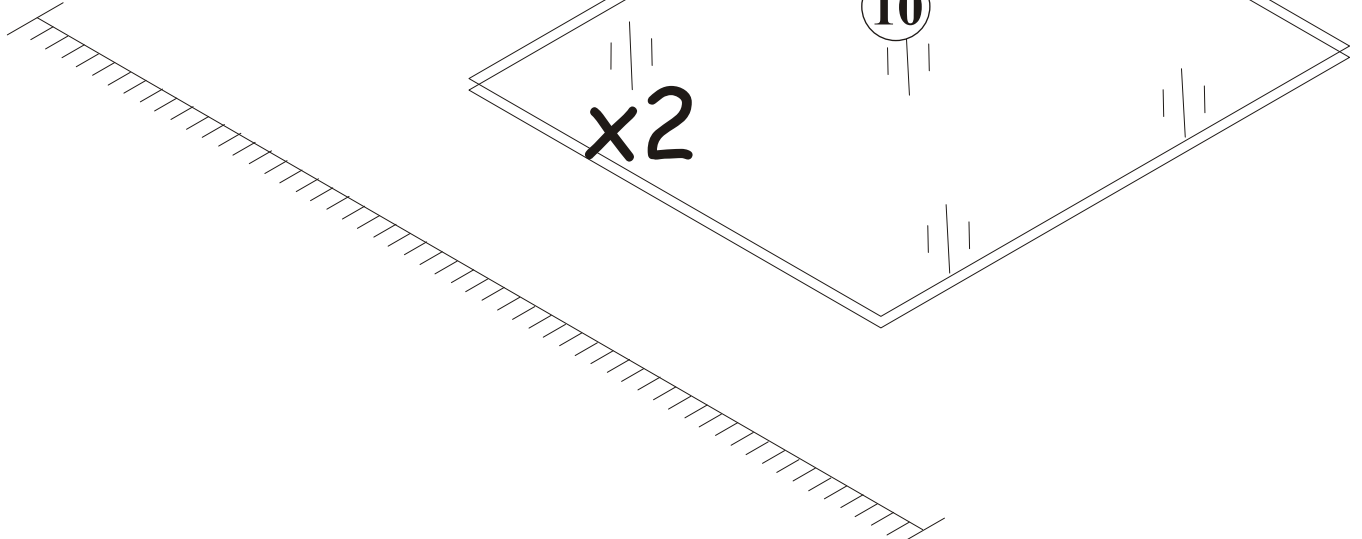

8

|      |  |
|------|--|
| UP13 |  |
| x5   | UPØ3x16  |

|     |   |
|-----|---|
| D10 |  |
| x6  | USØ3,5x13   |

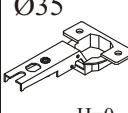
|     |   |
|-----|---|
| E21 | Ø35  |
| x3  | H=0   |

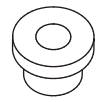
|    |   |
|----|---|
| P2 |  |
| x5 |   |

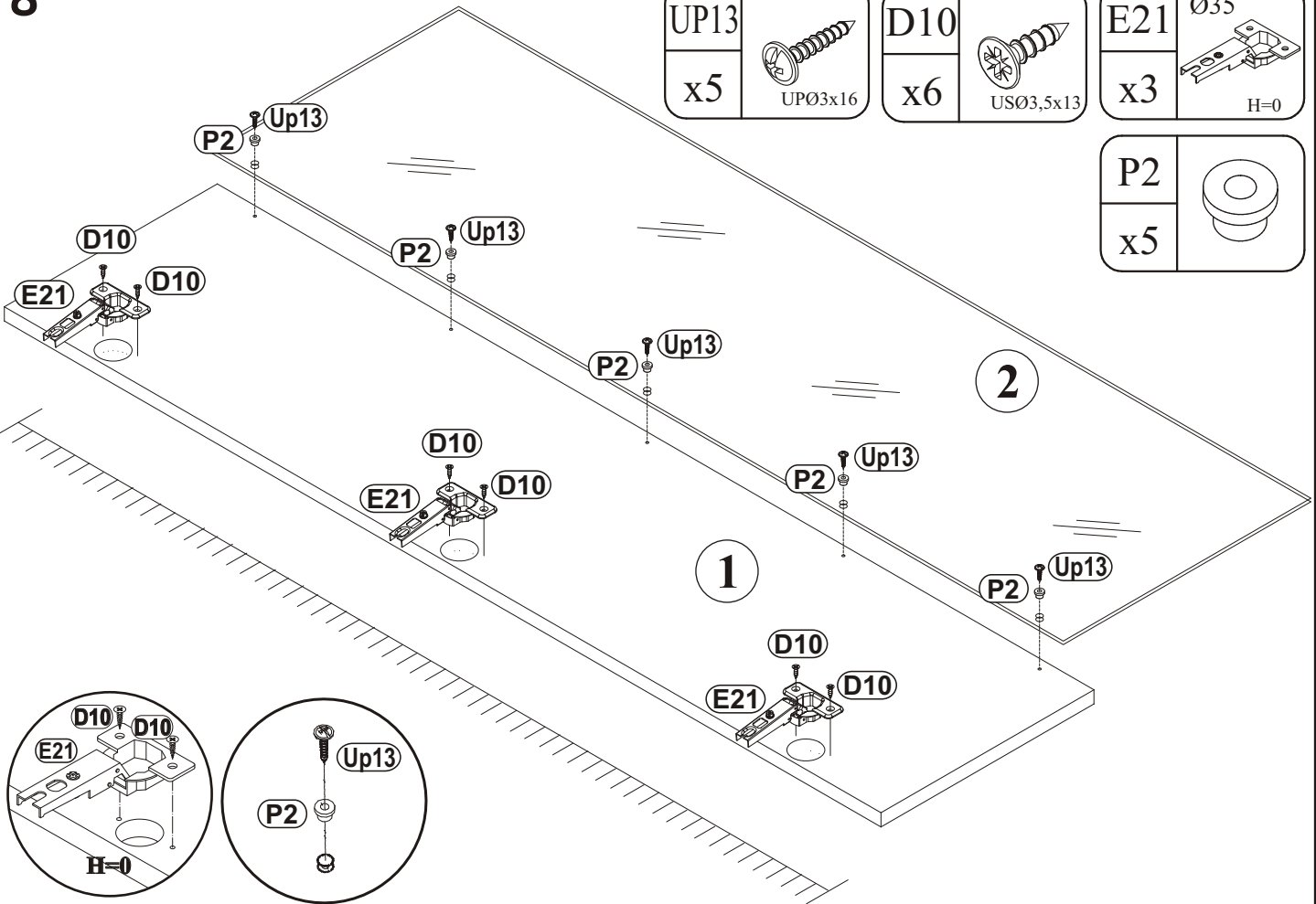

9

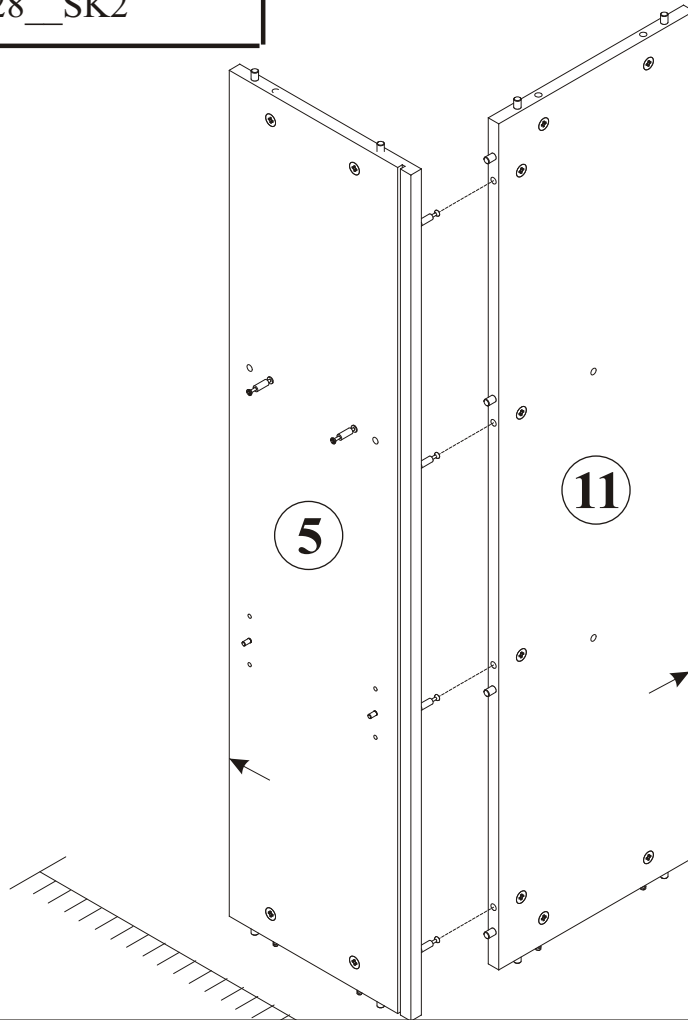

|    |  |    |  |
|----|--|----|--|
| G2 |  | G5 |  |
| x1 |  | x4 |  |

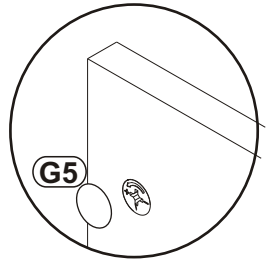
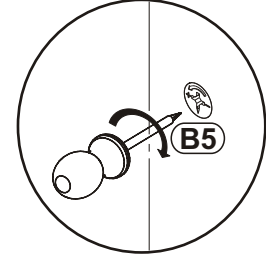
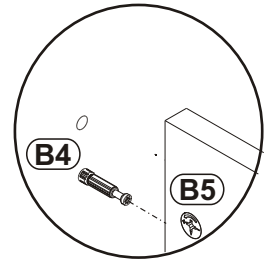

10

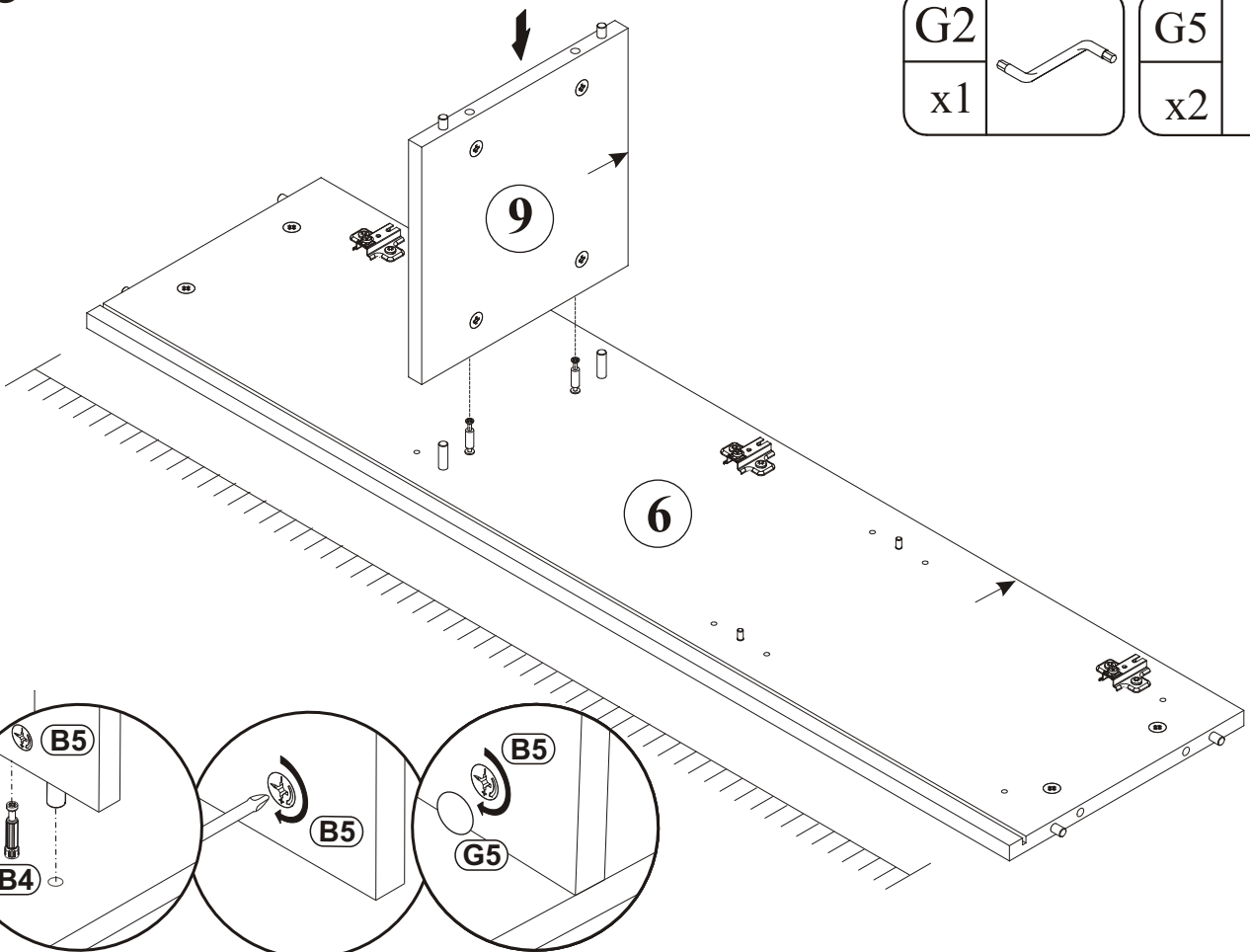

|    |  |    |  |
|----|--|----|--|
| G2 |  | G5 |  |
| x1 |  | x2 |  |

11

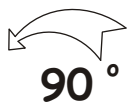
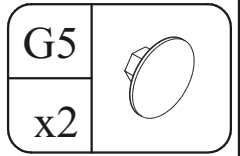
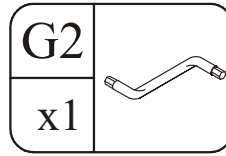
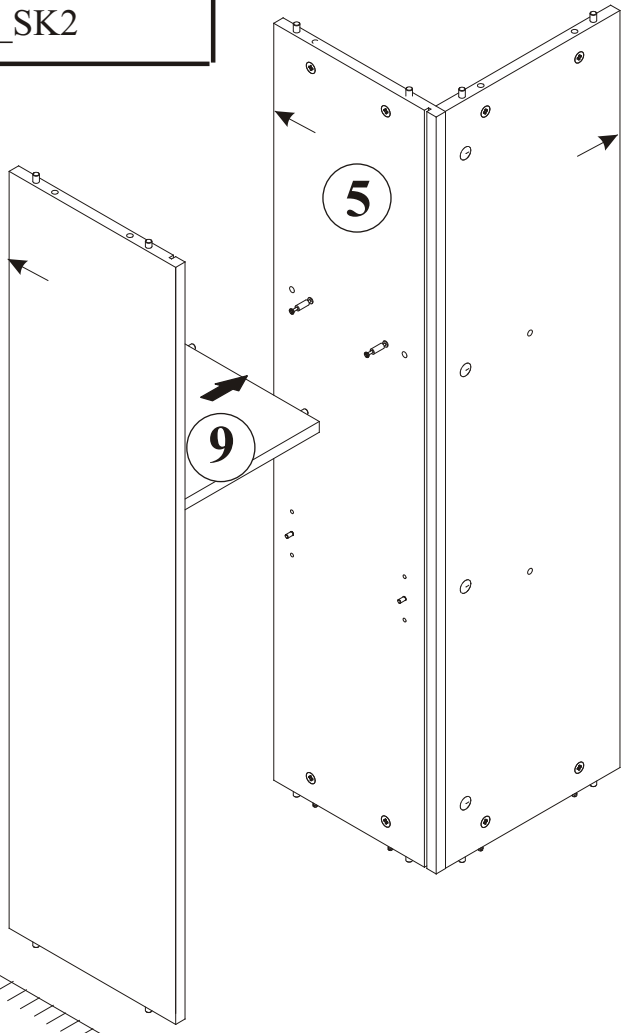
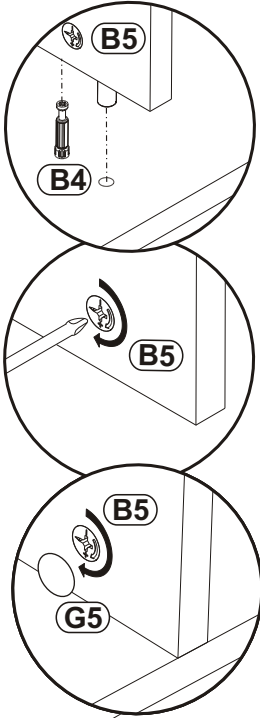

12

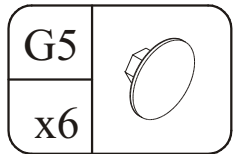
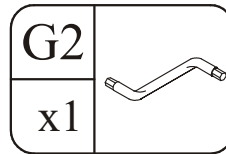
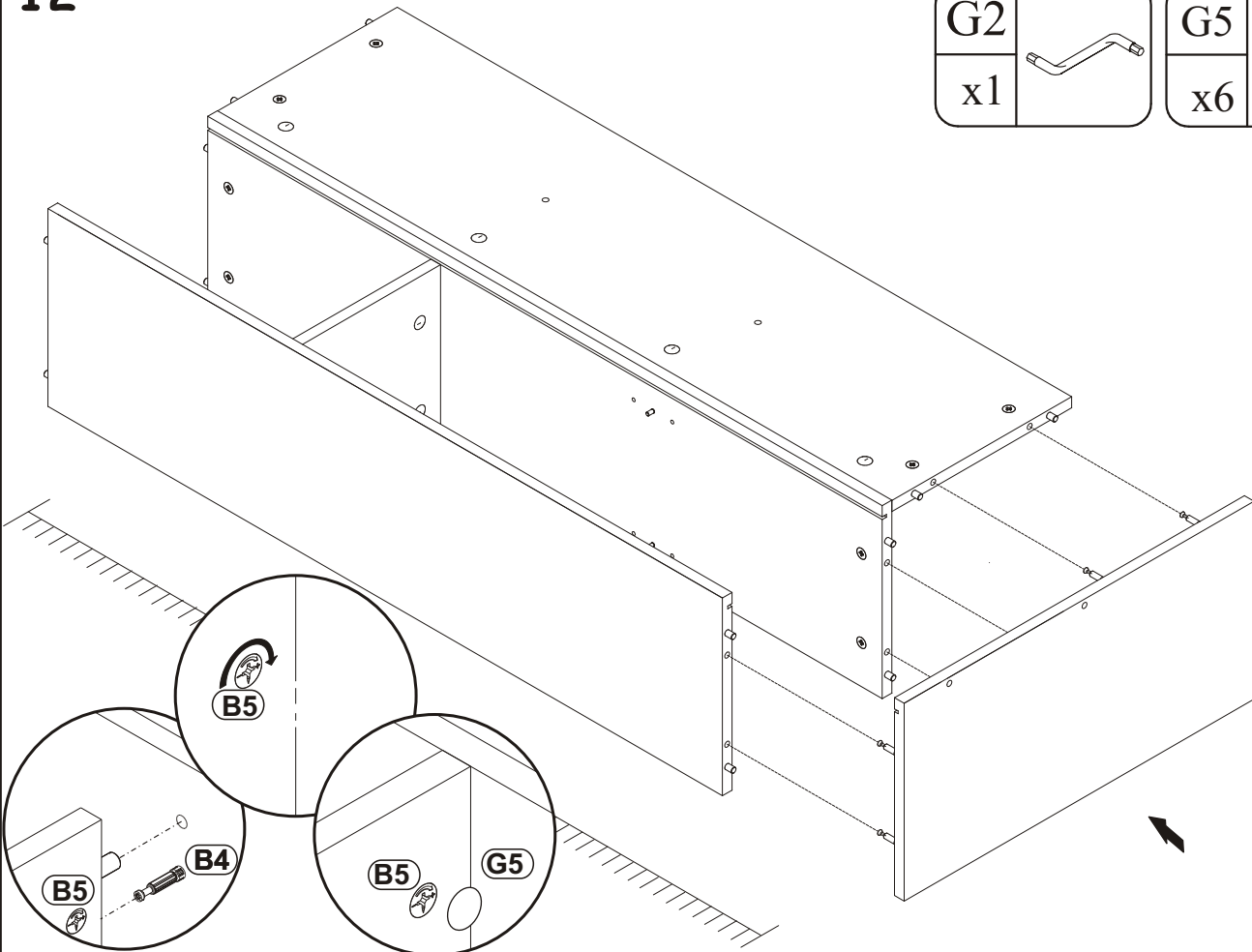

13

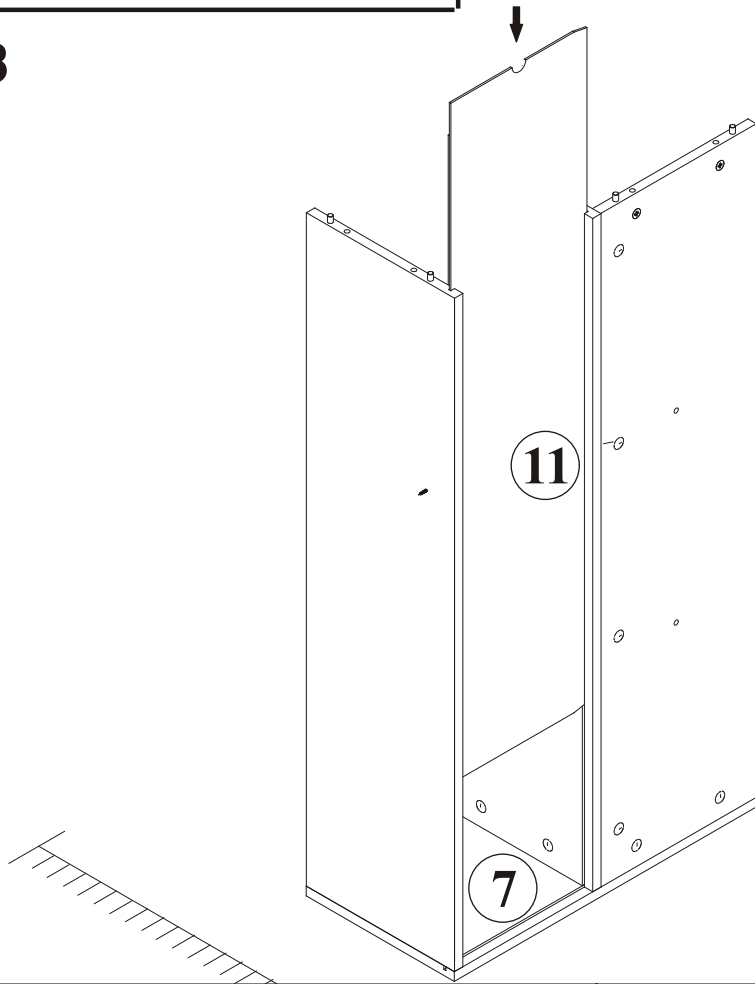

14

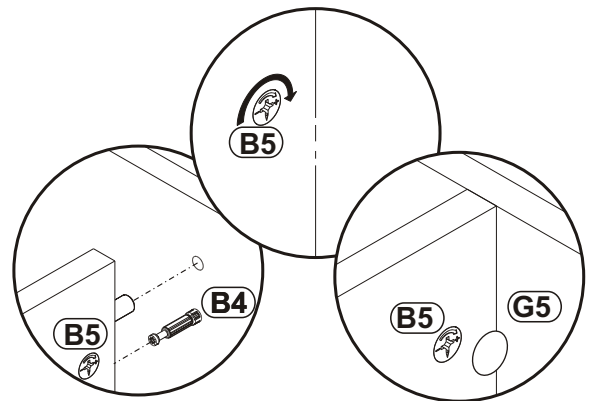
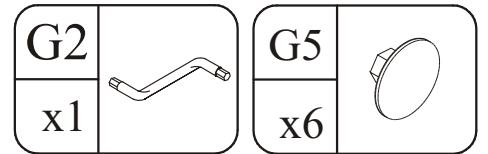
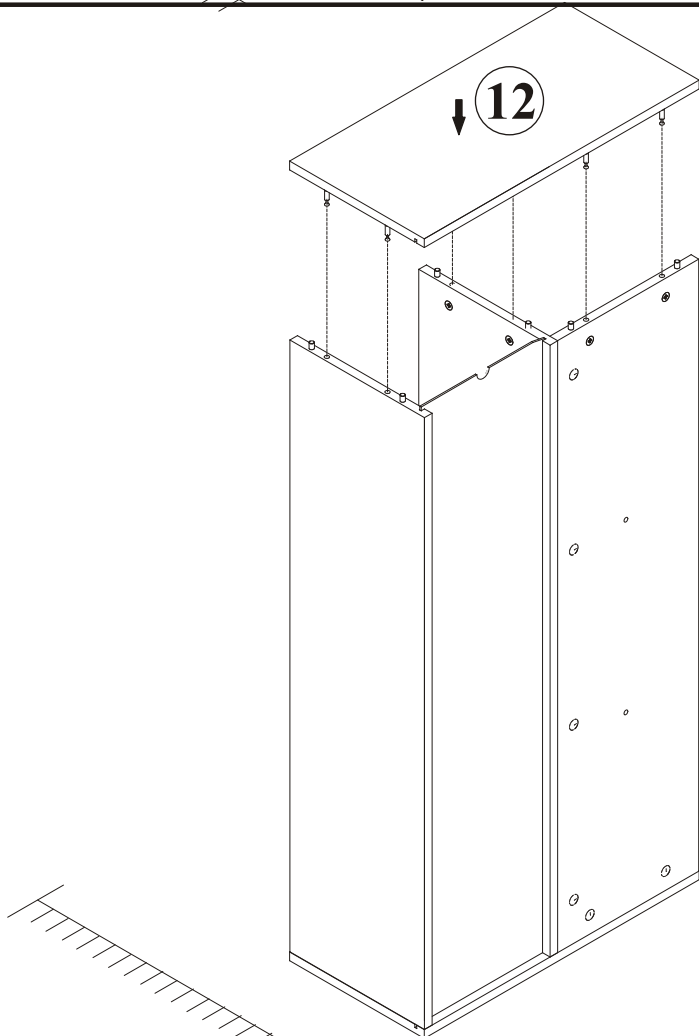



S1

x8

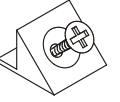

15

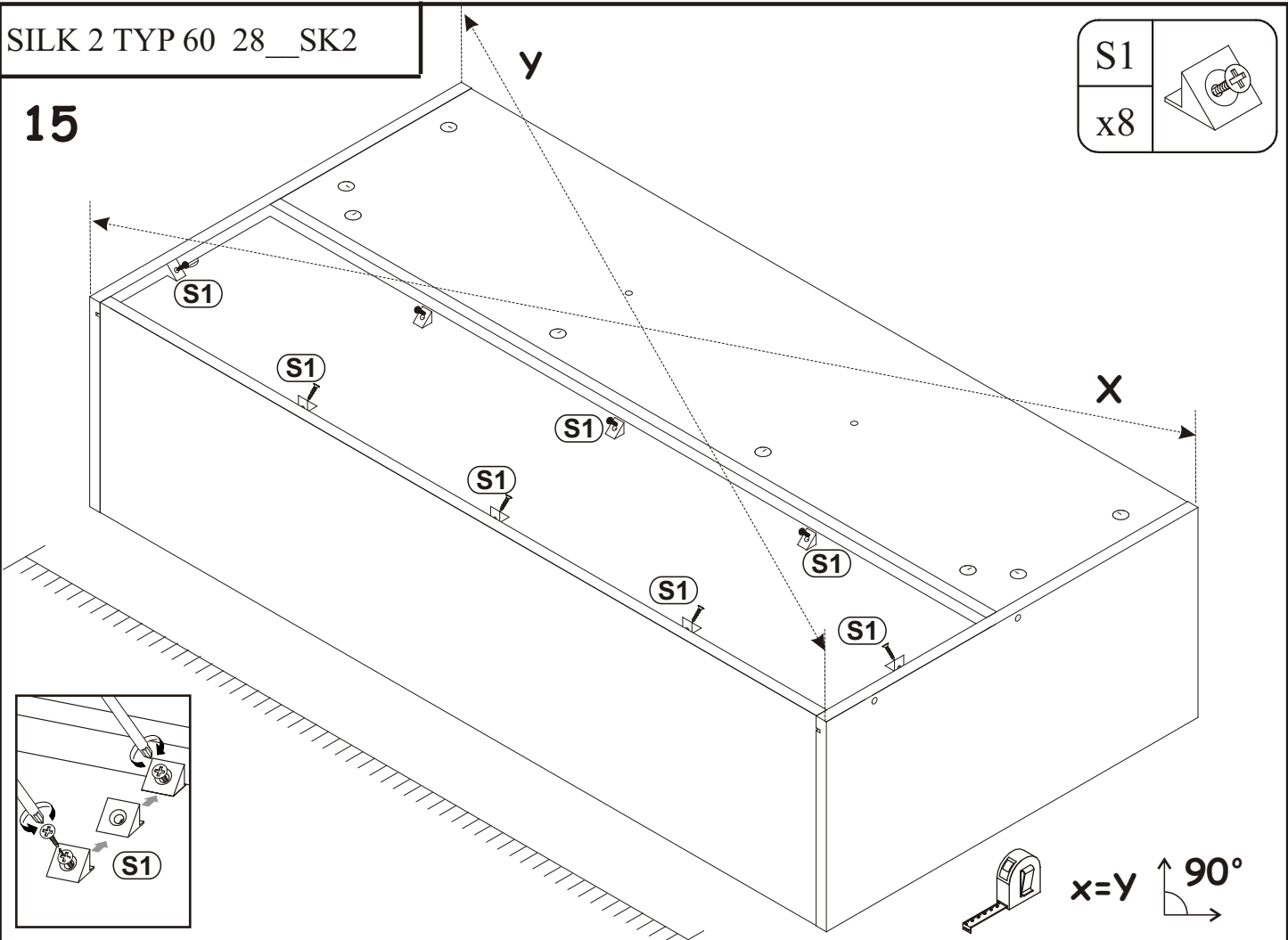

16

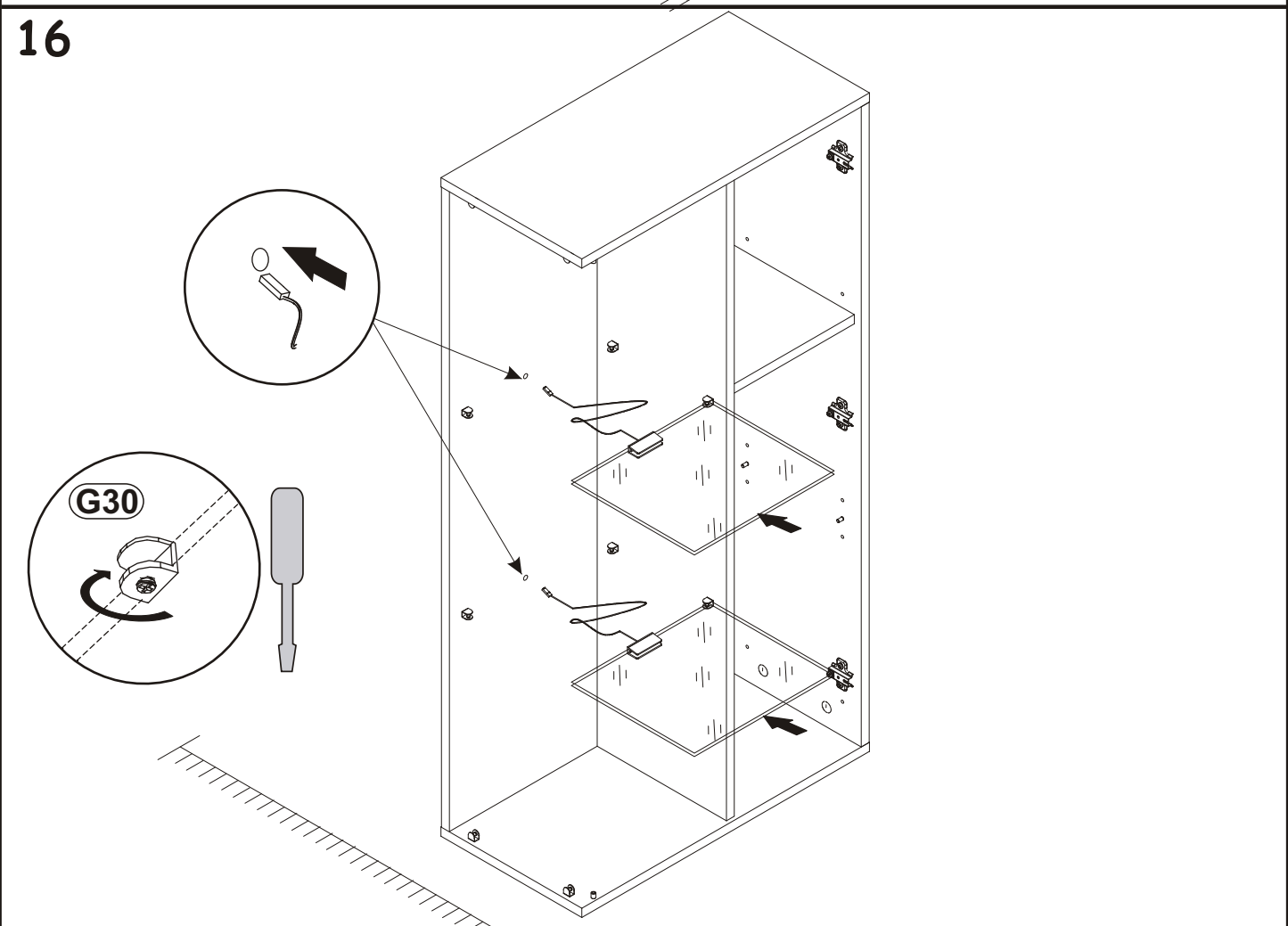

17

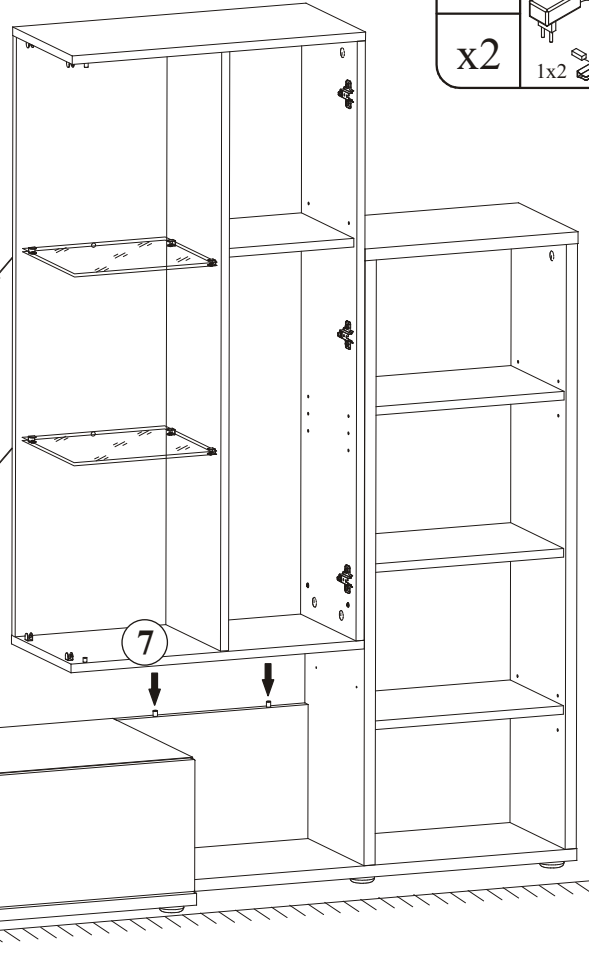
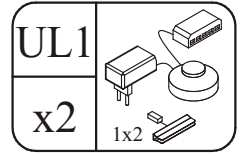
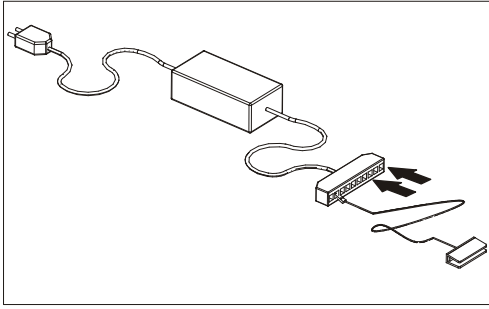

18

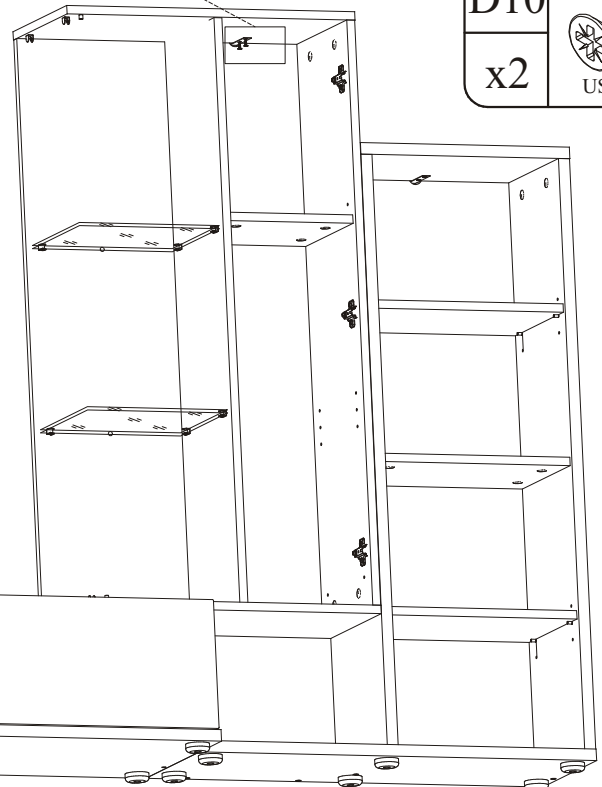
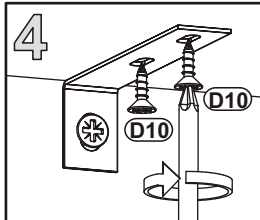
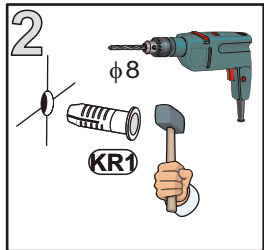
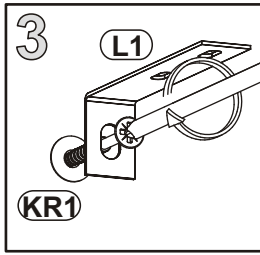
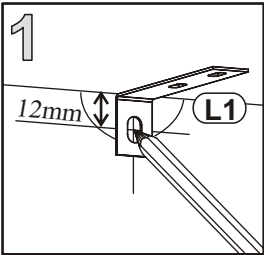
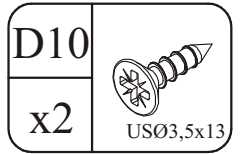
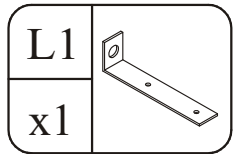
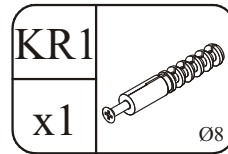
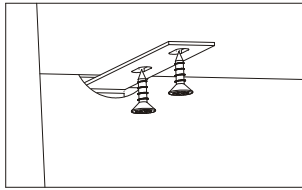
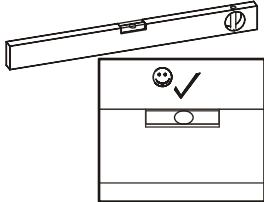

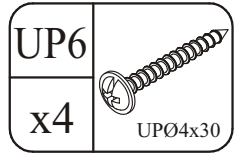

19

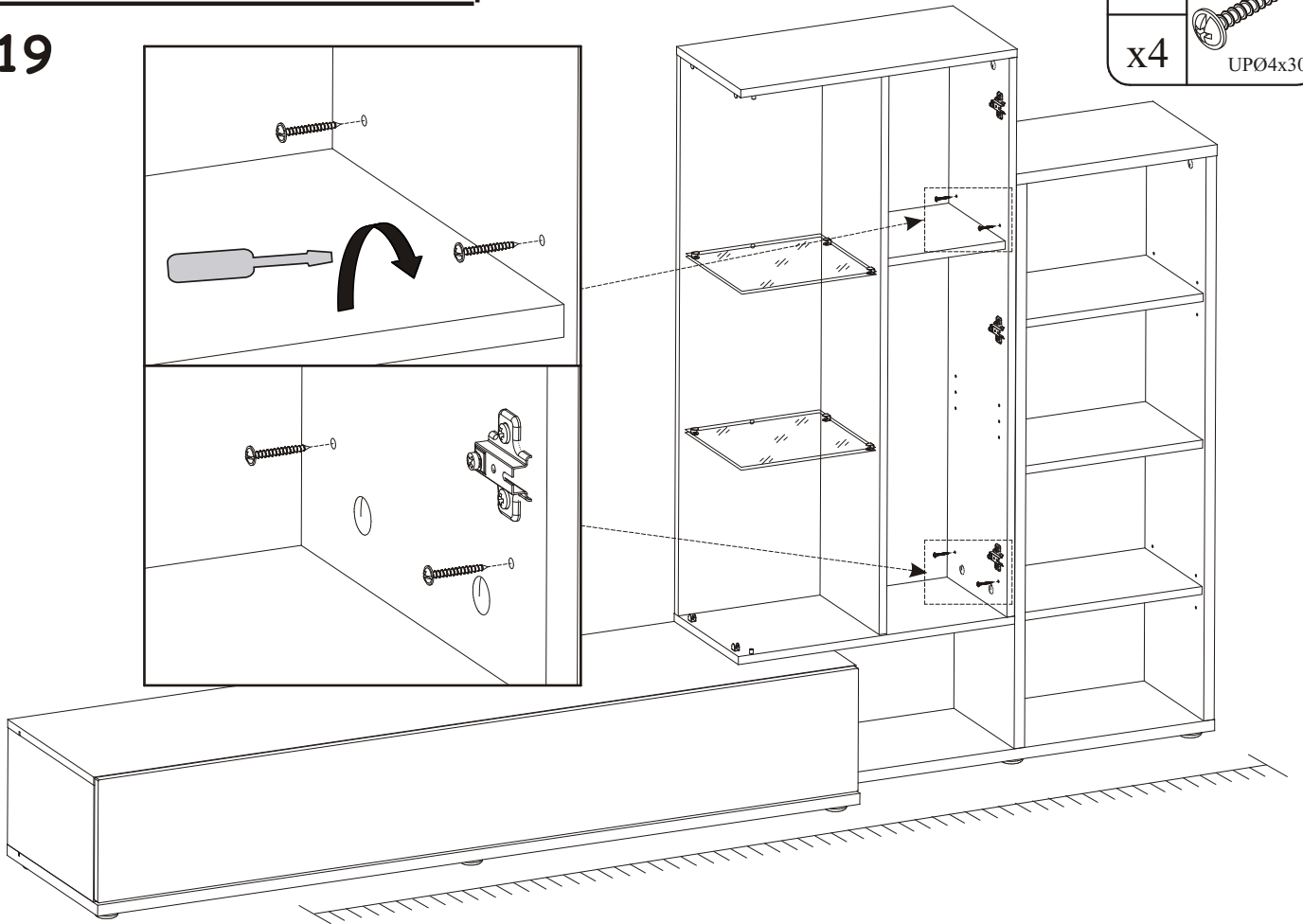

20

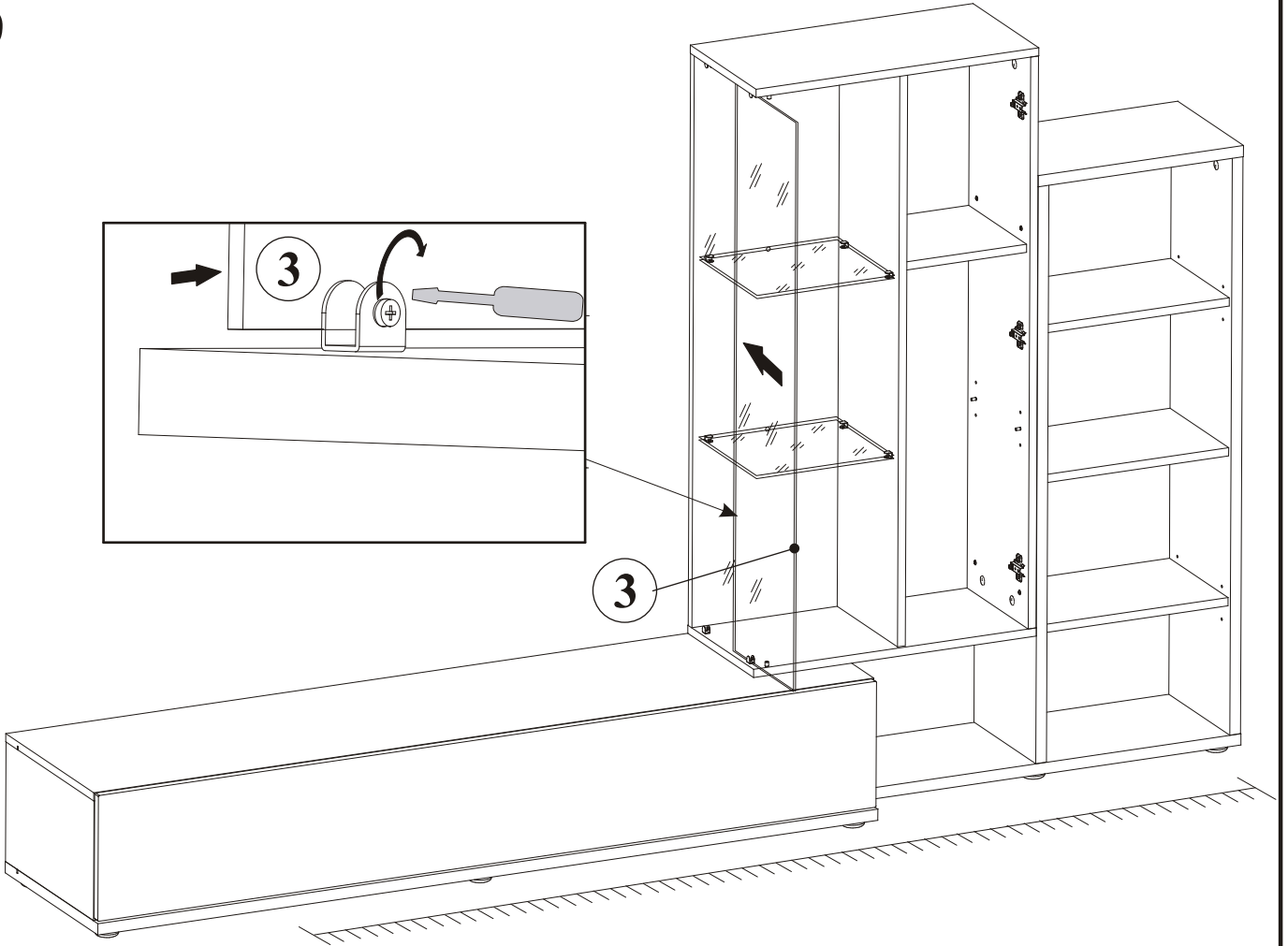

21

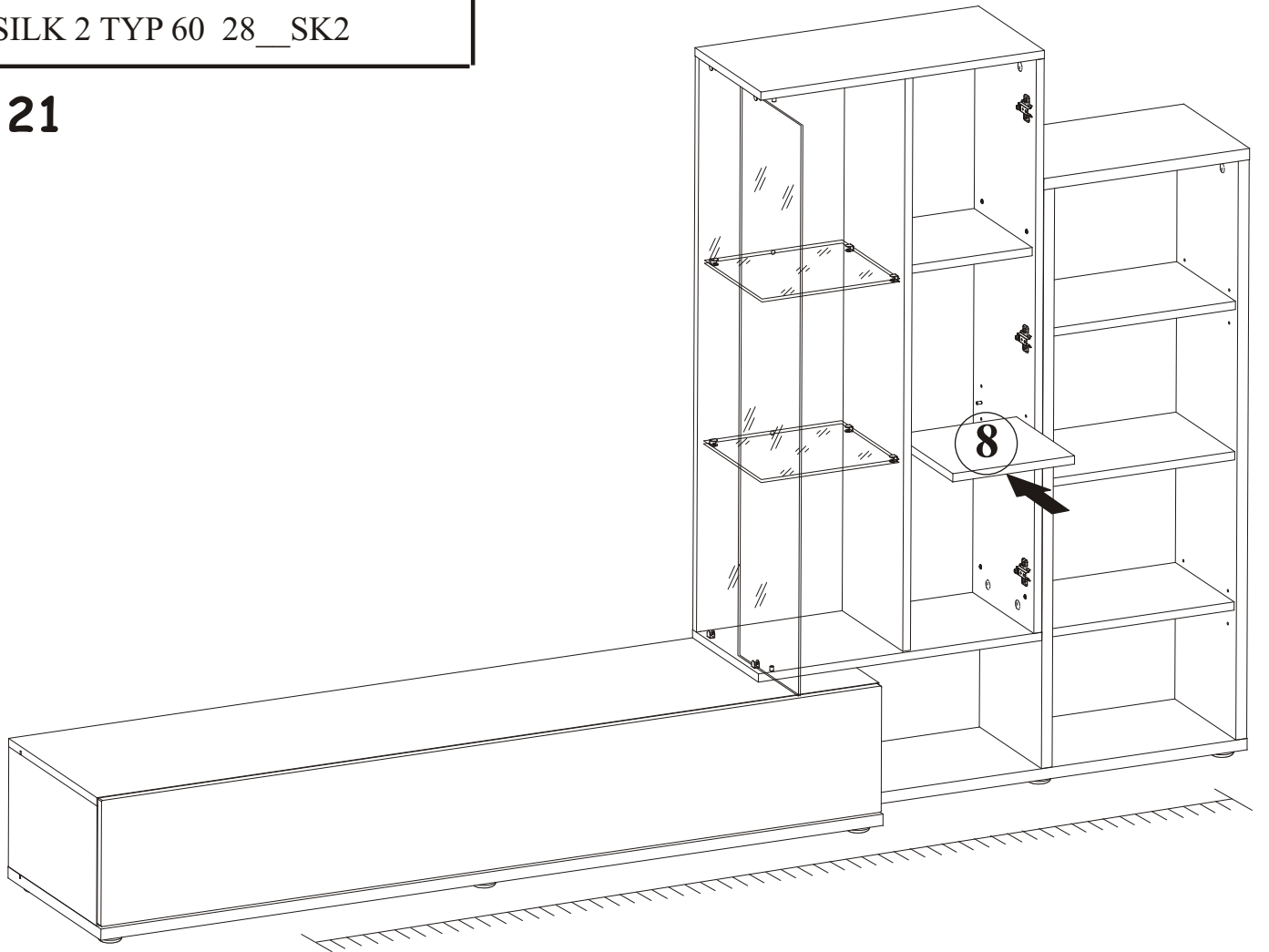

22

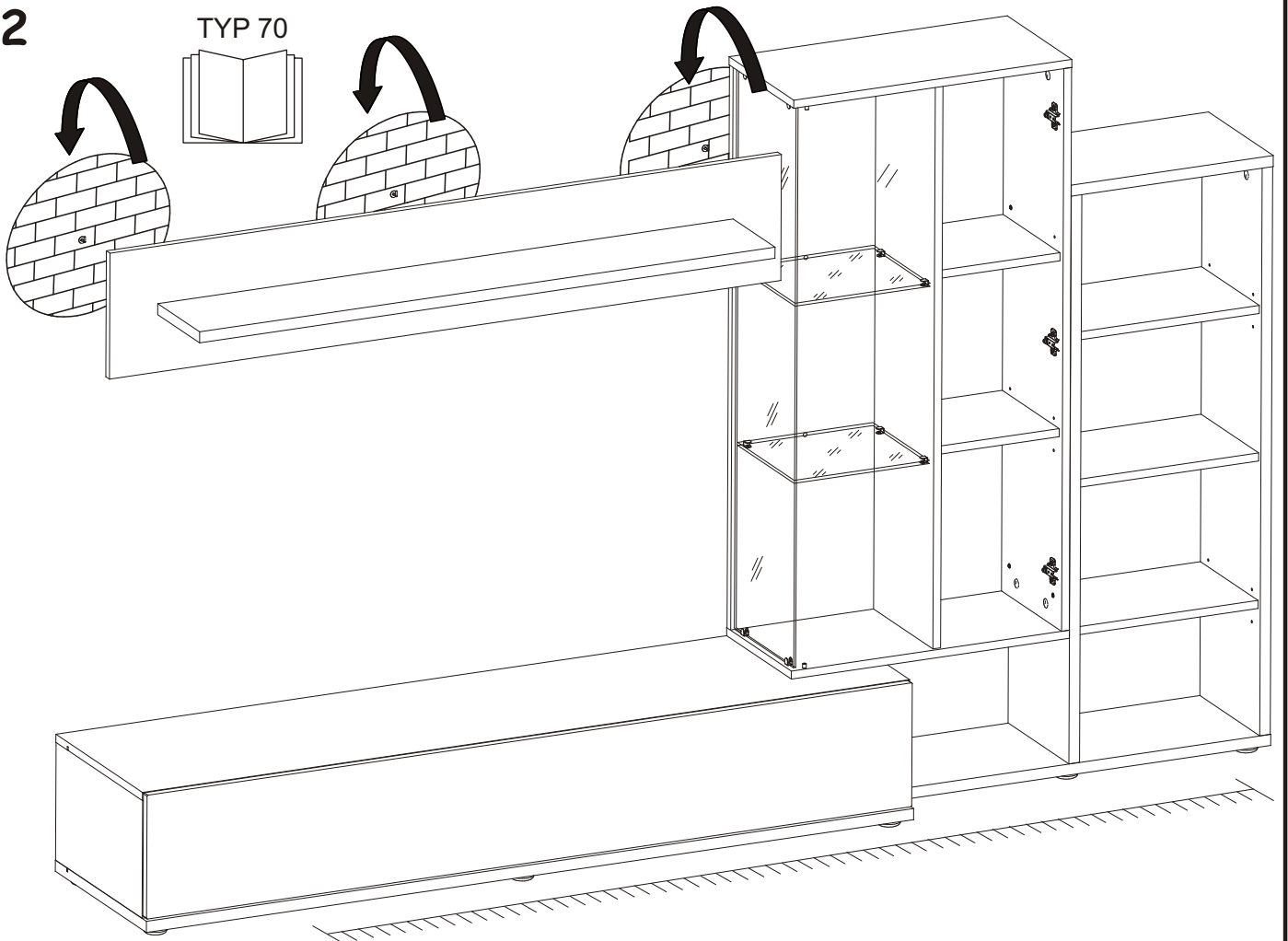

23

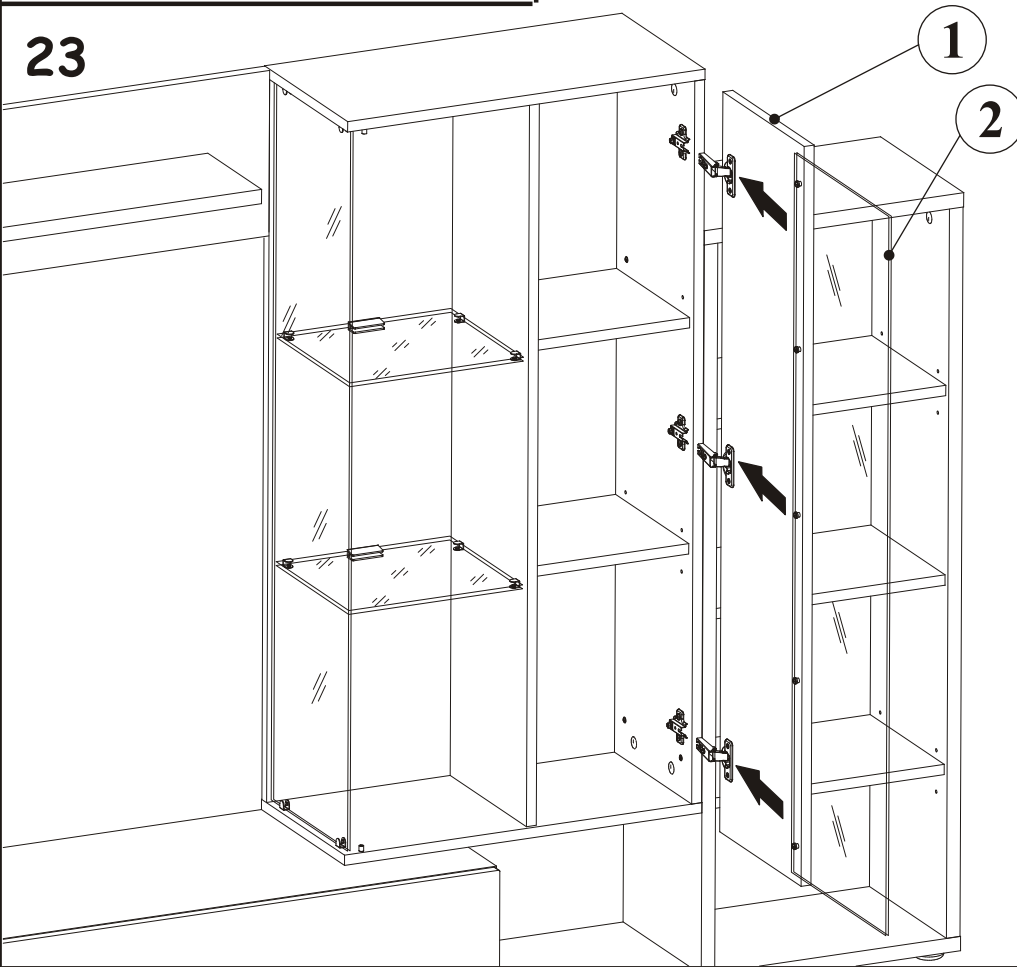

24

