

-08P2

Montageanweisung / Installation instructions / Instruction de montage / Istruzioni di montaggio
montagehandleiding / Instrukcja montażu / Montaj talimatlar / Osszeszerelési útmutató / Návod k montáži /
Návod na montáž / Instrucțiune de montaj / Инструкция по монтажу / Montaj talimatina / Monteringsanvisningar
Upute za montažu / Instrucciones de Montaje / Navodila za montažo

DAma/Miro/Prisma

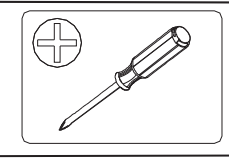
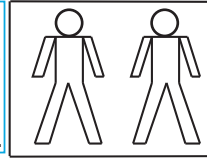

Total Kollis 3 Stuecke
Total colli 3 pieces
Numero total des colis:3
Colli totali 3
Totaal 3 colli's
Razem sztuk 3
Toplam parçalar 3
Celkem baličky 3
Teljes csomag 3
Celkom baličky 3
количество Всего 3
Total colete 3
Totalt antal kollin 3
Ukupno koleta 3
Bultos Totales 3
Skupno število paketov 3

D Bitte lesen Sie diese Montageanleitung gut durch, da wir für Fehler, die durch falsche Montage entstehen, keine Haftung übernehmen!

GB Please read these installation instructions through carefully as we cannot accept any liability for faults occurring as a result of incorrect installation!

CZ Přečtěte si prosím pozorně tento návod k montáži, aby jste předešli chybám vzniklých špatnou montáží, za které neručíme!

F Veuillez lire attentivement cette notice de montage, car nous déclinons toute responsabilité en cas d'erreurs découlant d'un montage erroné !

I Prego leggere attentamente le istruzioni per il montaggio, poiché decliniamo qualsiasi responsabilità per difetti derivanti da un montaggio errato

S Läs monteringsanvisningarna noggrant. Vi avsäger oss allt ansvar för defekter som uppstår p.g.a. felaktig montering.

HR Pažljivo pročitajte upute za montažu, jer otklanjamo svaku odgovornost za pogreške nastale uslijed pogrešne montaže.

SLO Prosimo, da pozorno preberete navodila za montažo, saj zavračamo vsakršno odgovornost za napake, ki bi nastale zaradi napačne montaže.

NL Lees u alstublieft deze montagehandleiding goed door, voor fouten door verkeerde montage zijn wij niet verantwoordelijk.

PL Proszę uważnie zapoznać się z instrukcją montażu, ponieważ nie ponosimy odpowiedzialności za niewłaściwy montaż.

HU Kérjük, olvassa el figyelmesen ezt az összeszerelési útmutatót, mert a helytelen összeszerelésből a dódó hibáért nem vállalunk felelősséget!

SK Prosíme, dobre prečítajte si tento návod na montáž, pretože nepreberáme žiadne ručenie za chyby, ktoré vzniknú na základe chybnej montáže!

RO Vă rugăm să citiți cu atenție aceste instrucțiuni de montaj deoarece nu preluăm garanția pentru defecte ce apar datorită unui montaj incorect!

RUS Пожалуйста, внимательно ознакомьтесь с данной инструкцией по монтажу, поскольку мы не несем ответственности за ошибки, причиной которых является неправильный монтаж.

TU İlkonce kullanma klavuzunu iyi okkuyun, yalnızca montaj yapasanız bunun sorumlusu biz degiliz.

E Se ruego leer con atención las instrucciones de montaje debido a que declinamos cualquier responsabilidad por defectos derivados de un montaje erróneo

LC S.p.A
Via del Piano s.n
61030 Isola del Piano (PU)
Italia

SERVICEKARTE

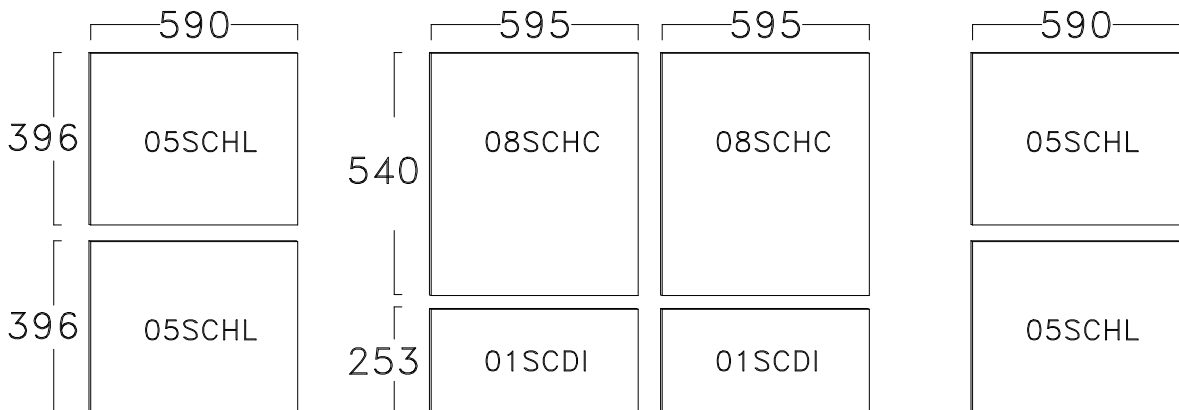
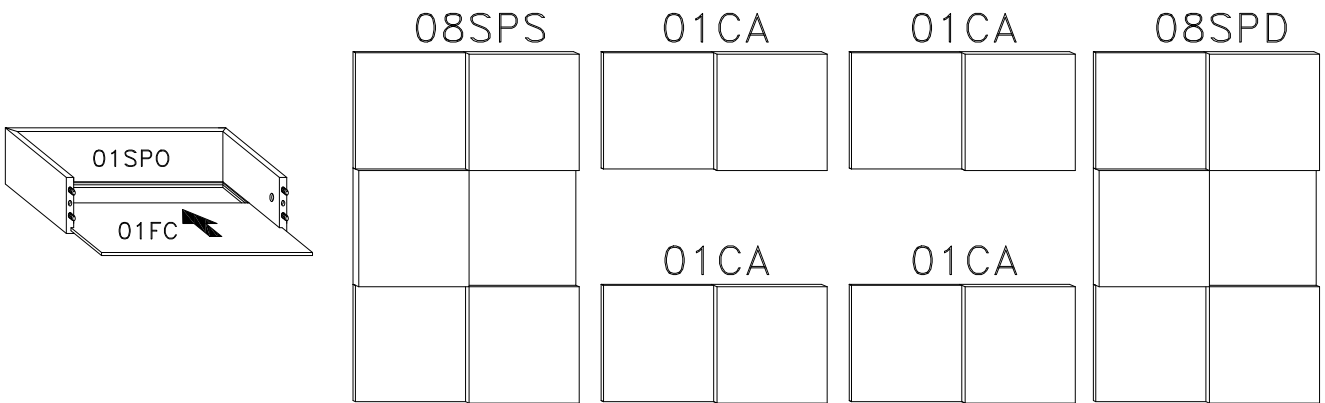
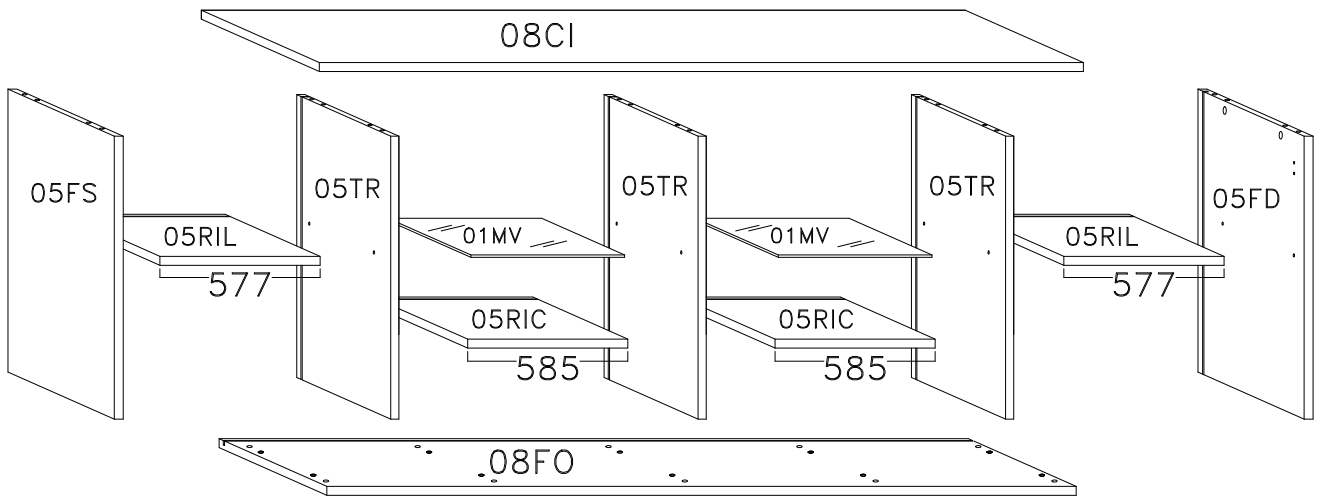
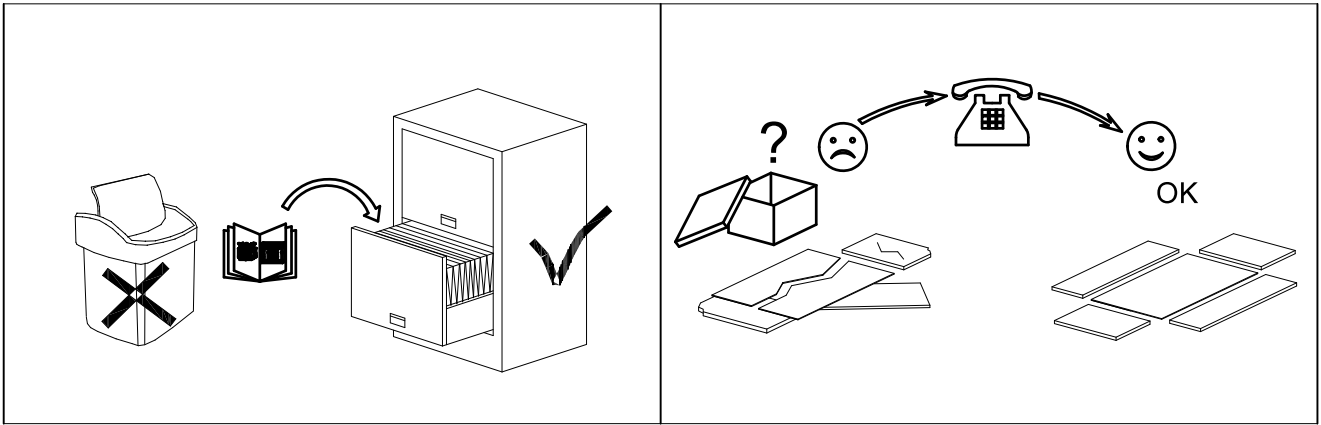

ONDERDELEN LYST-SERVICEKARTE-FORMULAIRE DEMANDES SAV-SPAREPARTS LIST-SCHEDA DI SERVIZIO

BESLAG-BESCHLAEGE - QUINCALLERIE - HARDWARE - FERRAMENTA

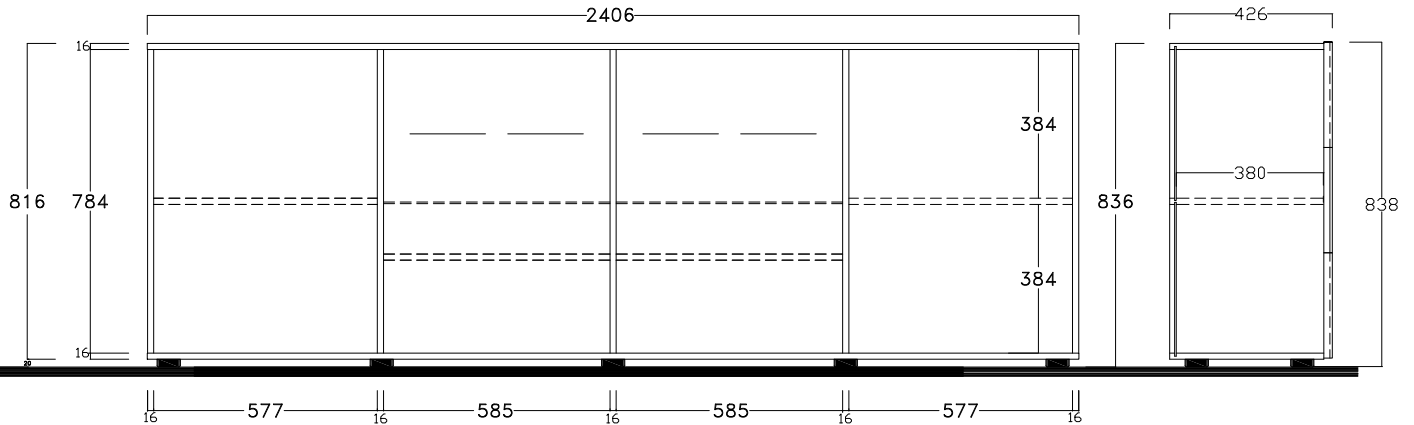



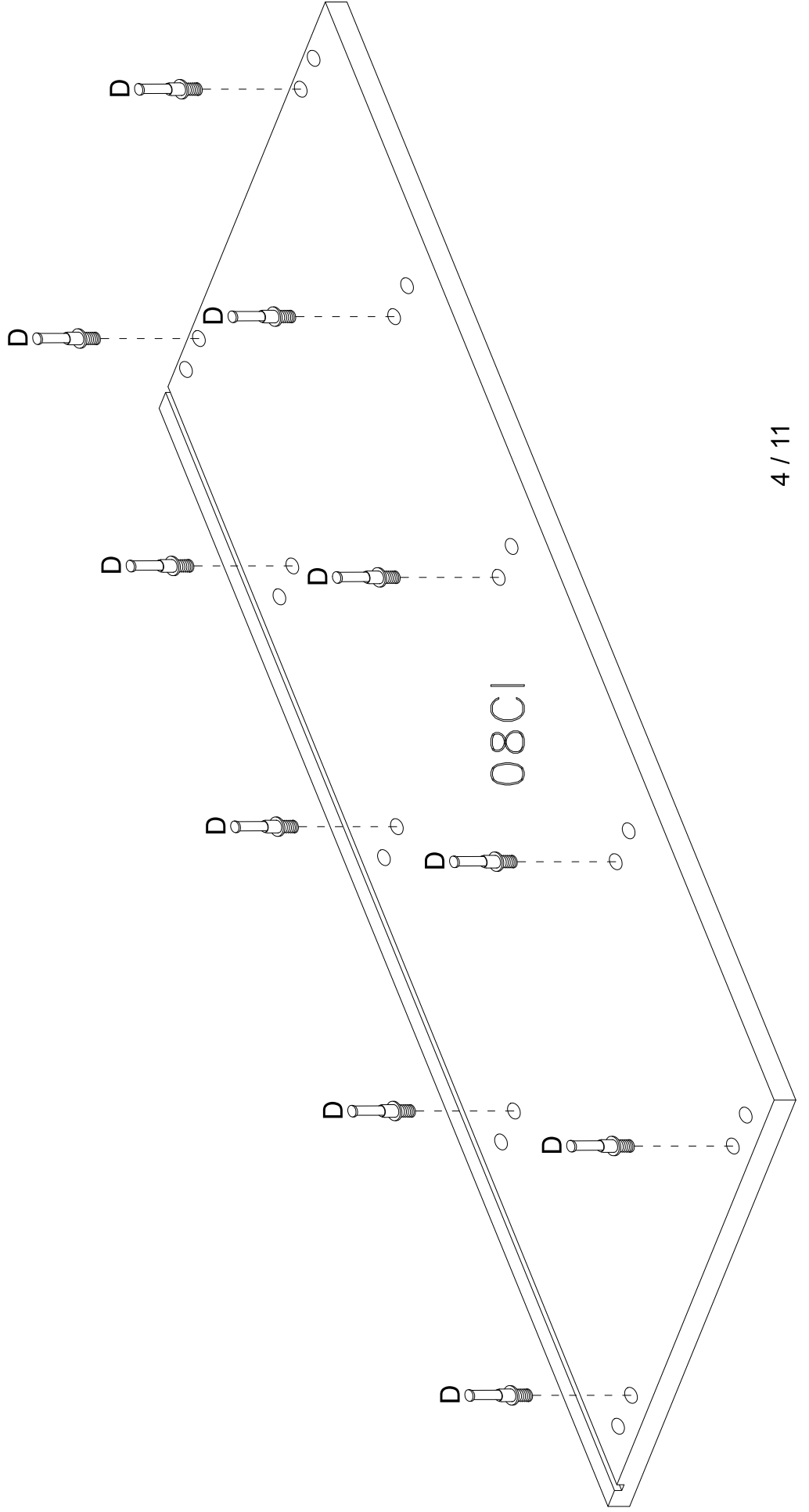
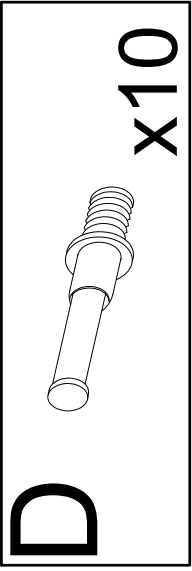

209008-08CF		L4530		4.5x30 mm.	x7
F		x56			
B		L3516		3.5x16 mm.	x16
	8x30 mm.	x20			
C		P			x12
	∅16 mm.	x10			
D		R1			x8
		x10			
E		R			x16
	7x60 mm.	x10			
		T20			x10
		∅20 mm.			
C1	209008-08SCFS	M9		6x9 mm.	x16
		x16			
	∅12 mm.				
D1		x16			
209008-08CC		H2T			x4
		C0			x4
		L15		4x15 mm.	x8
209493-07GUI		CL			x4
		CR			x4
		DR			x4
		DL			x4
205124-06PIE		F21		∅ 60 mm h 20 mm	x7

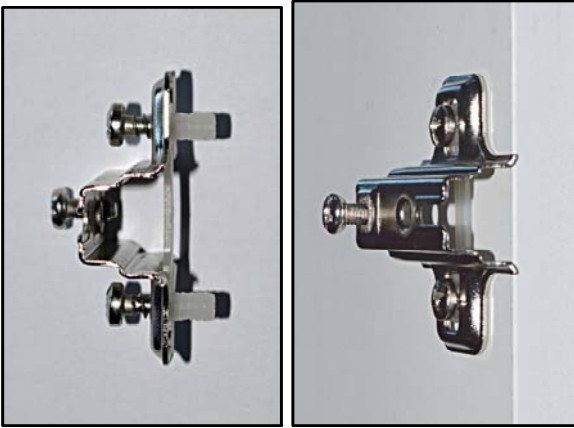

1

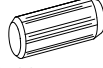
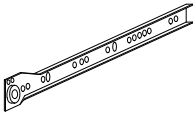
H2T

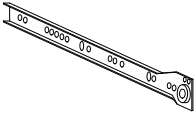

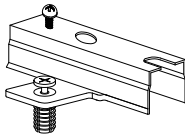
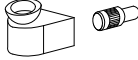
B	 8x30 mm.	x20	CL	 0 00 00 00 00 00 00	x4
M9	 6x9 mm.	x16	CR	 00 0000 00 00 00 00	x4
R		x16	H2T		x4
R1		x8			

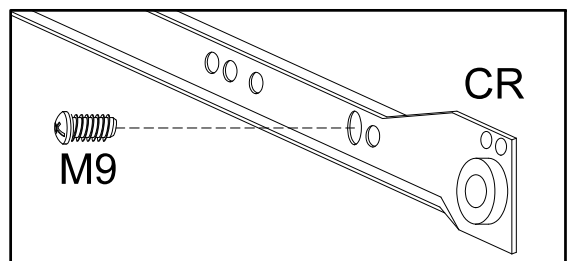
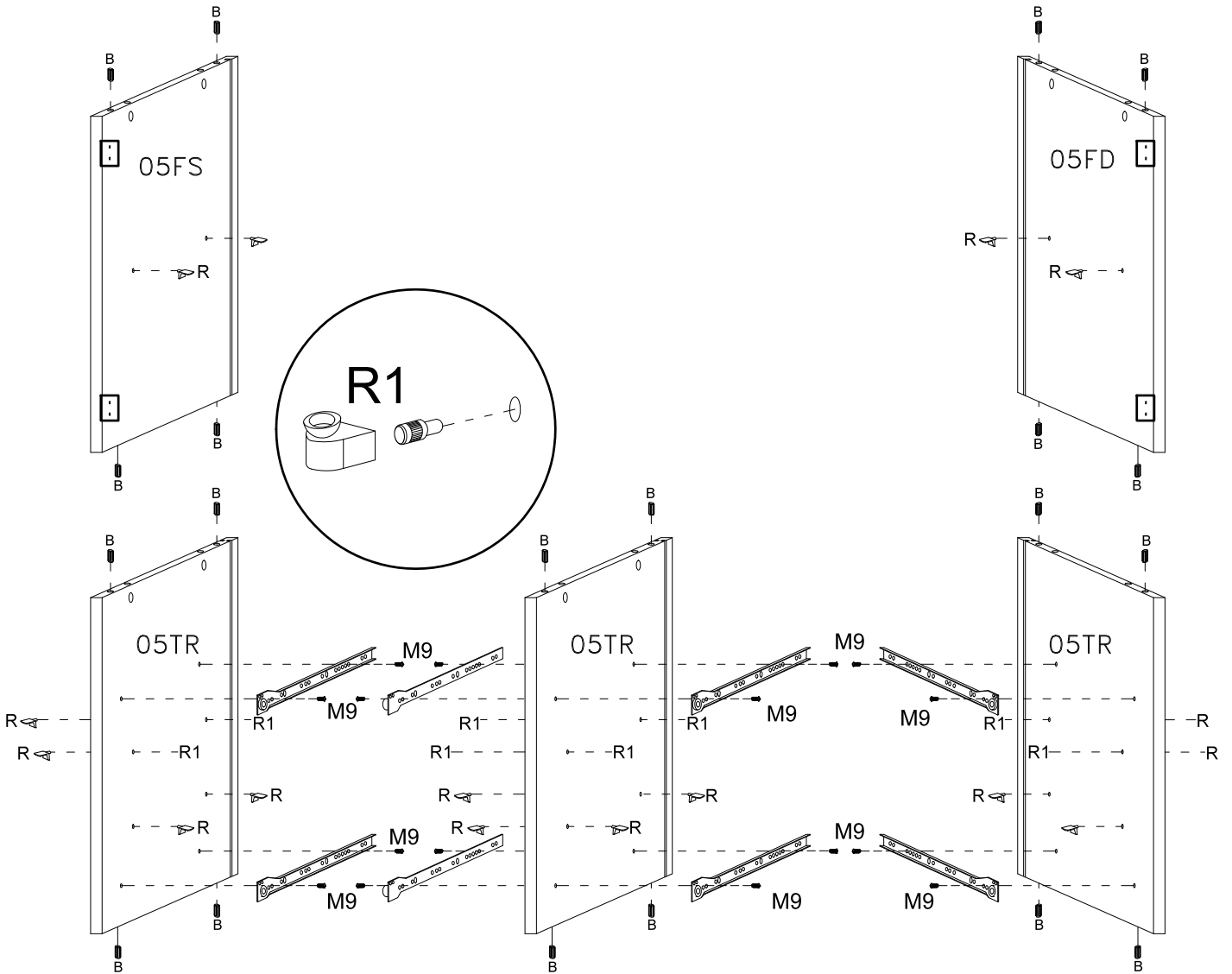

2

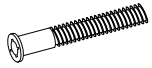
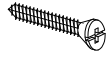
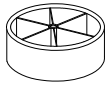
<p>E</p>  <p>7x60 mm. x10</p>	<p>L4530</p>  <p>4.5x30 mm. x7</p>	<p>F21</p>  <p>Ø 60 mm h 20 mm x7</p>
---	---	---

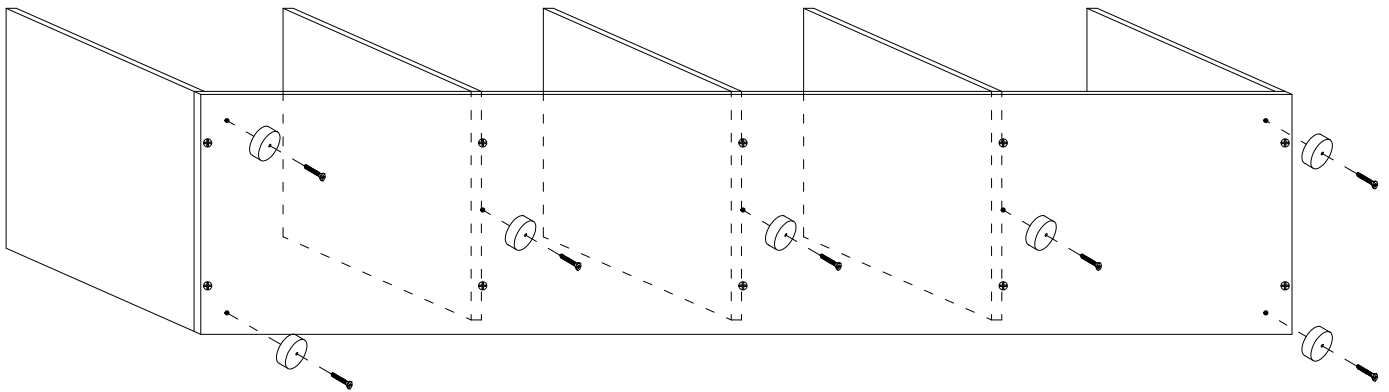
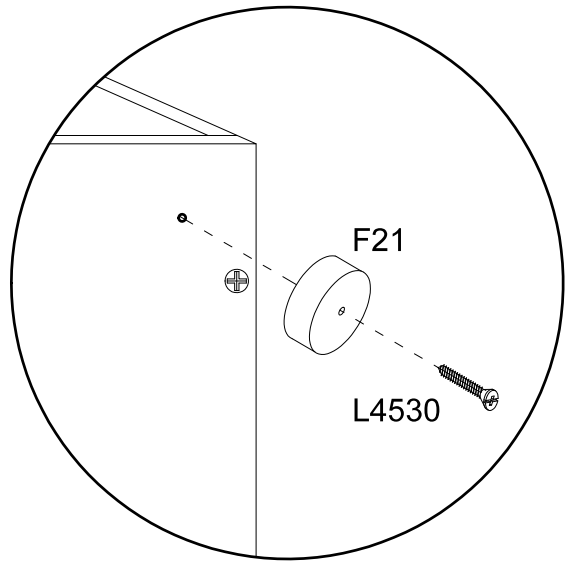
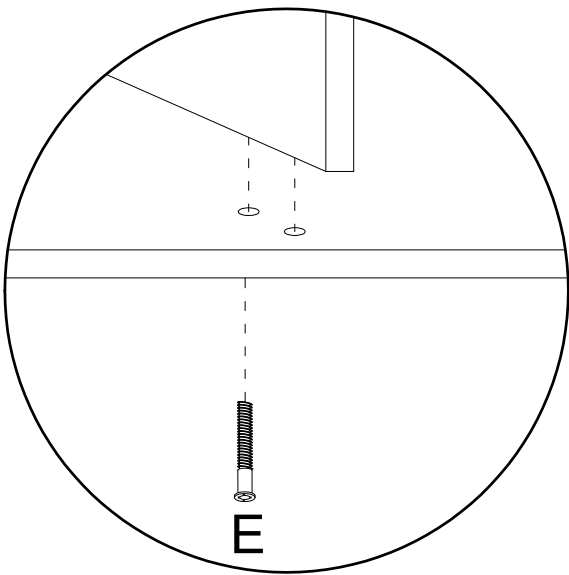
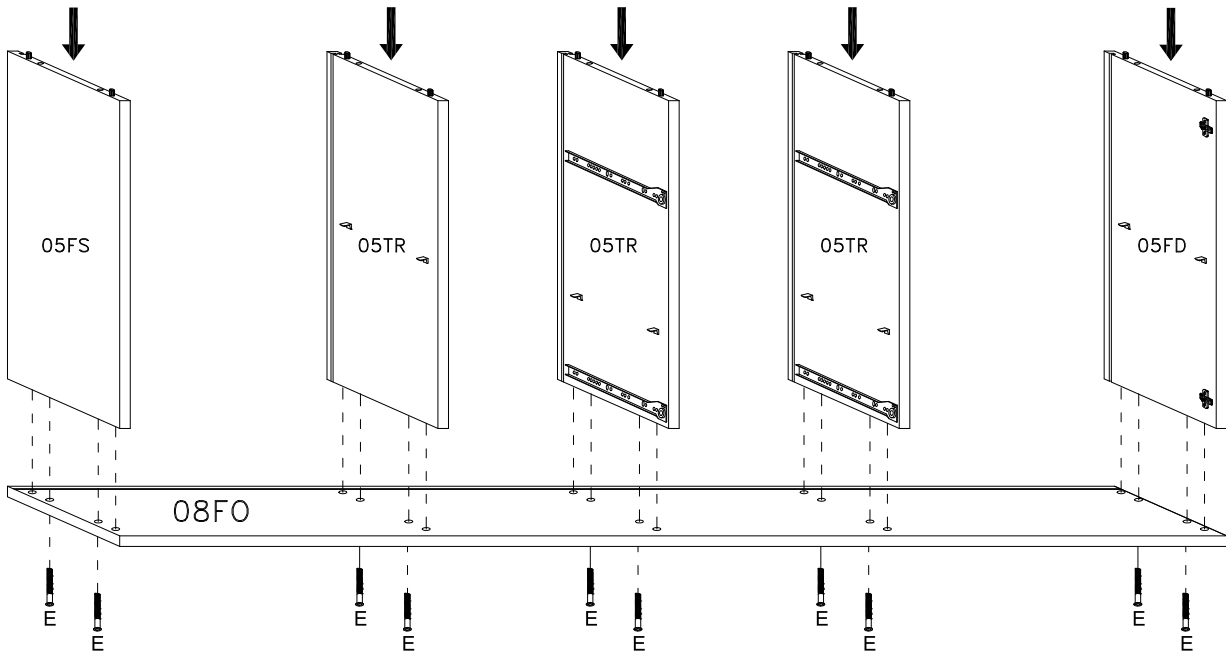

3

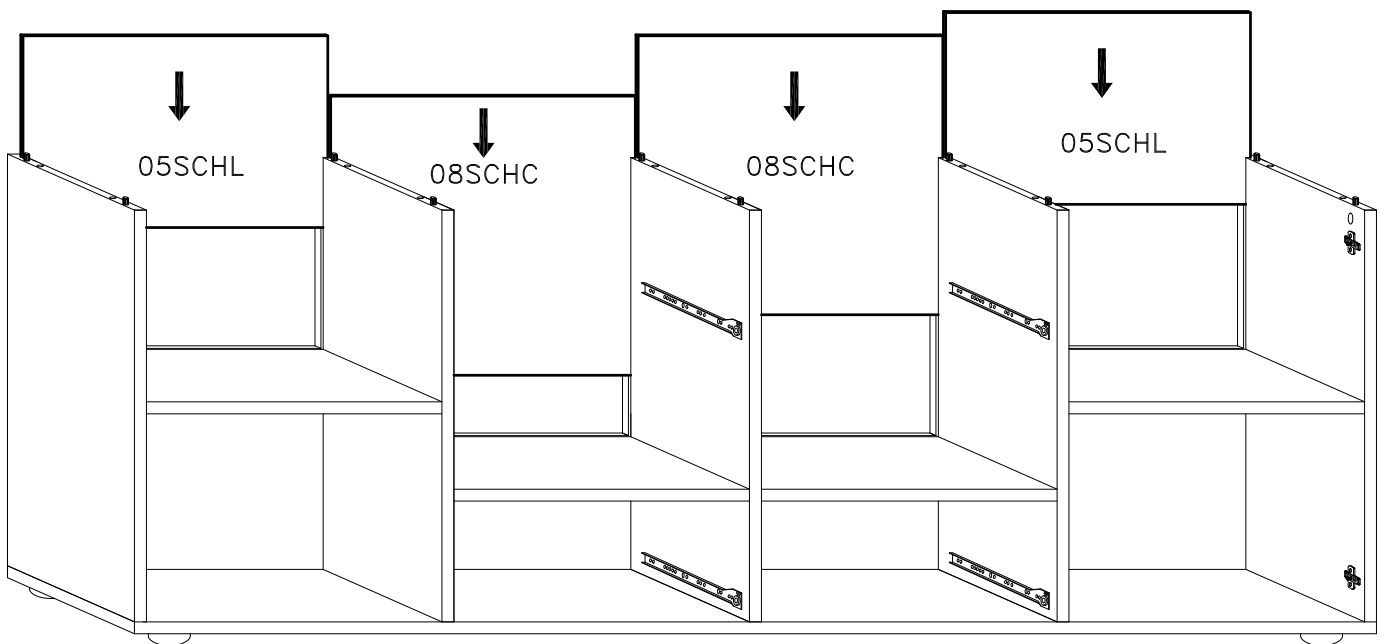
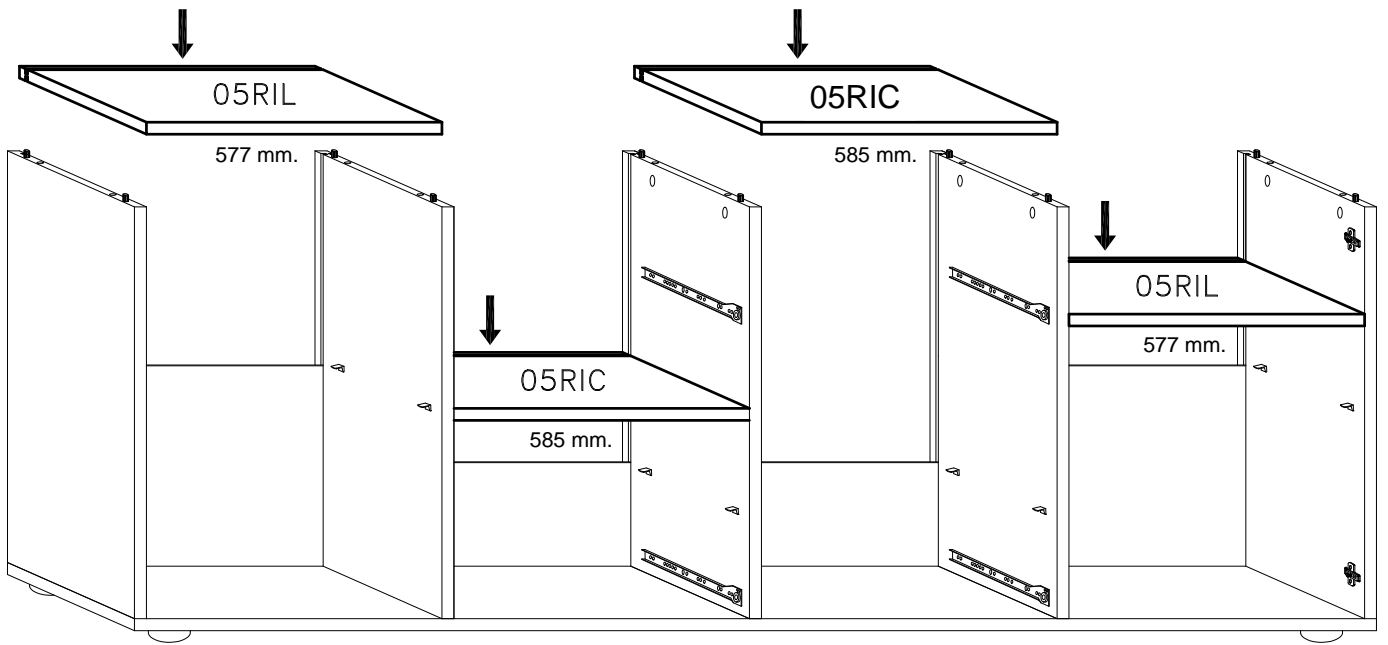
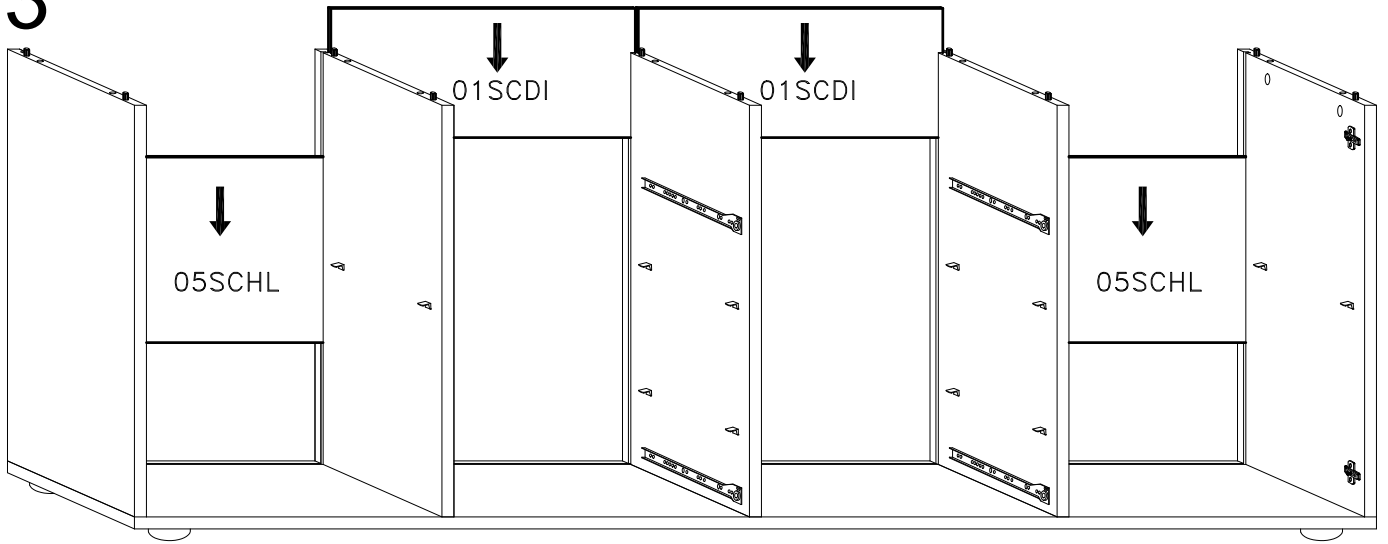

4

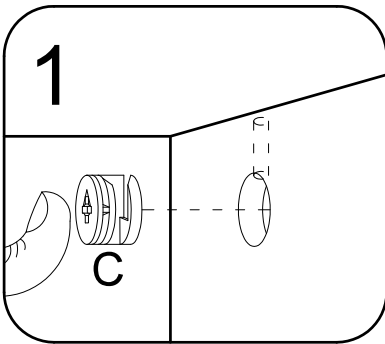
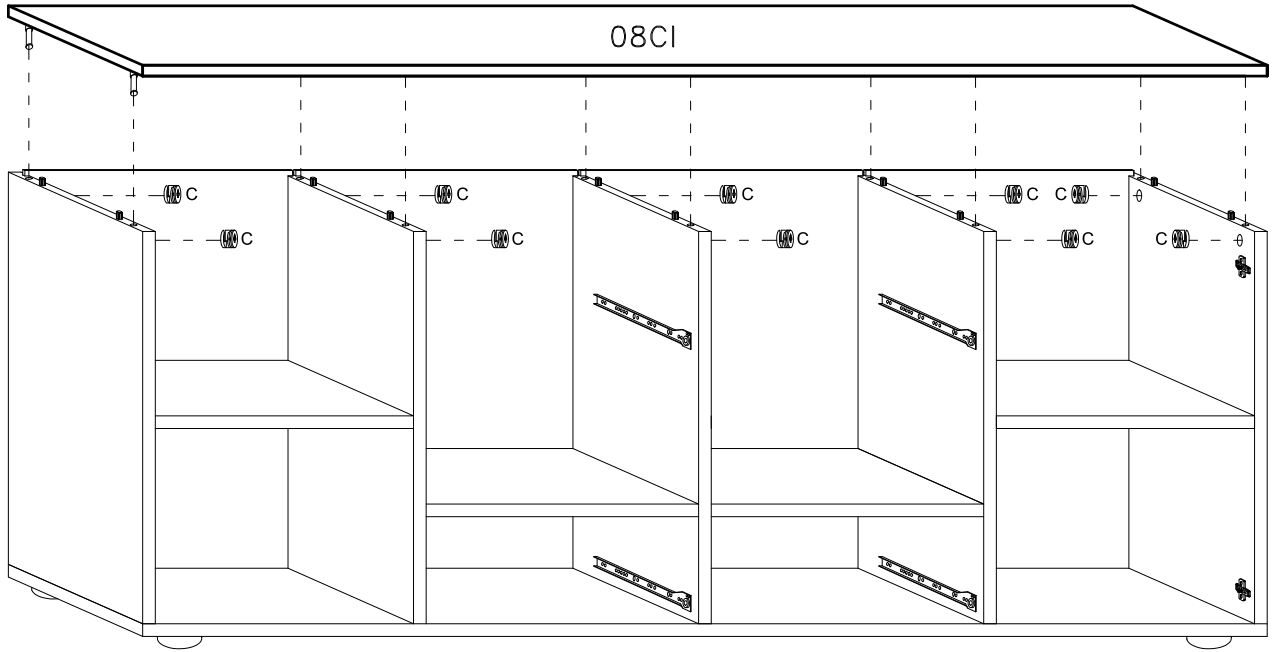
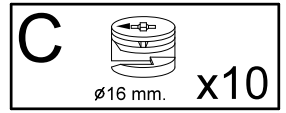

2

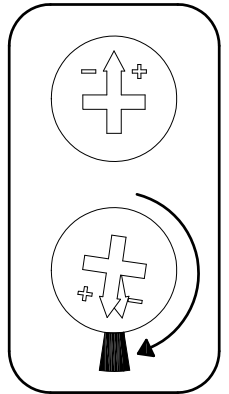
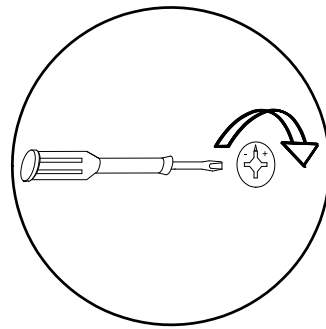

5

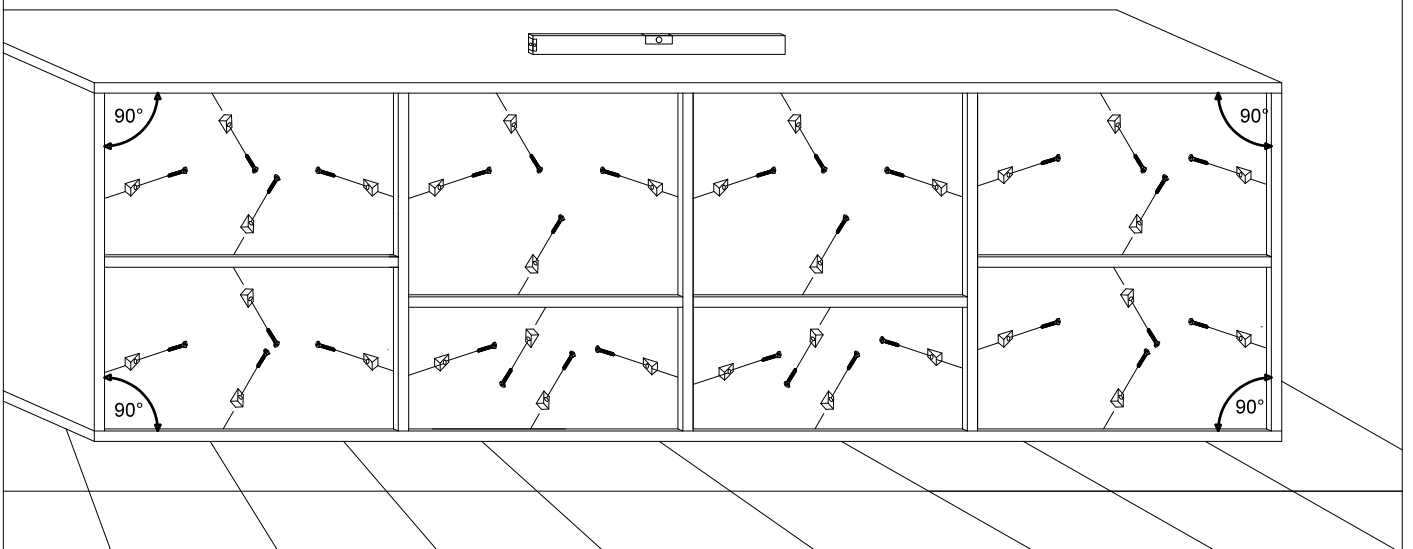
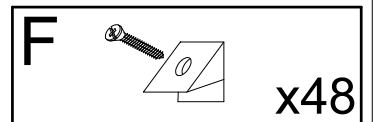
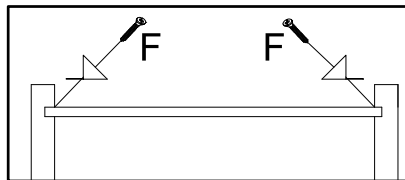
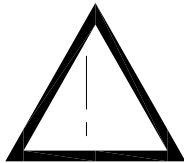

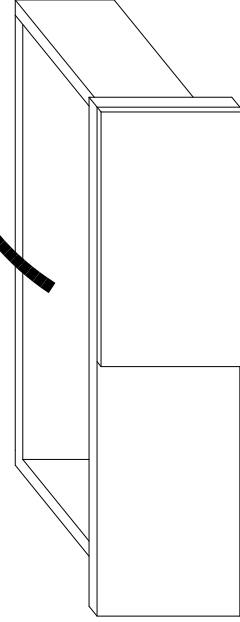
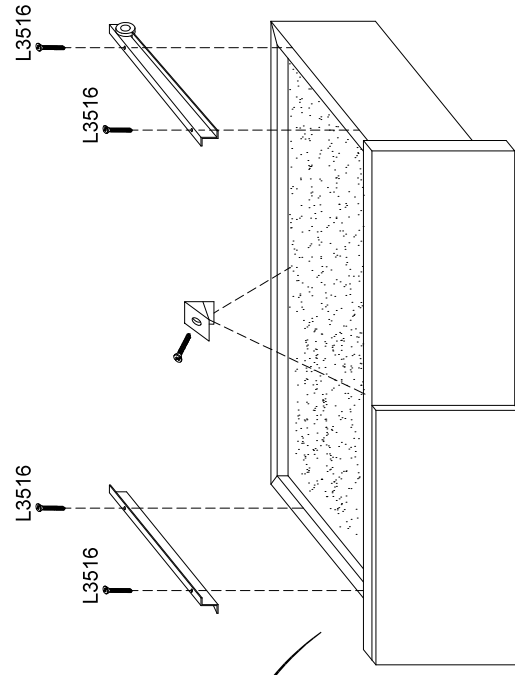
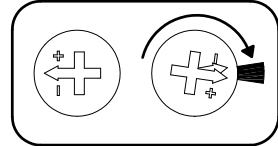
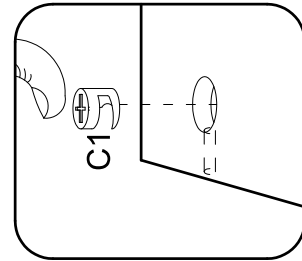
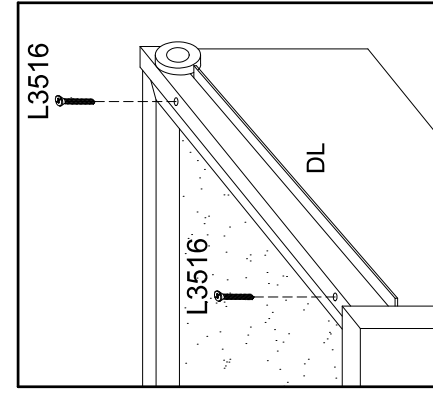
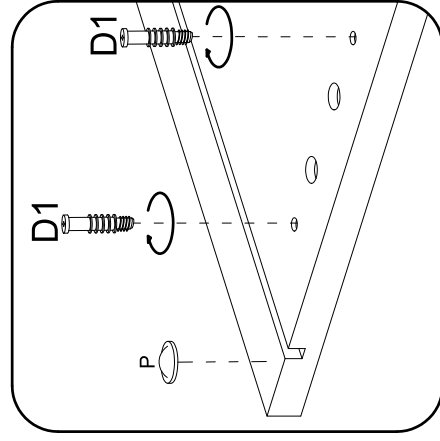
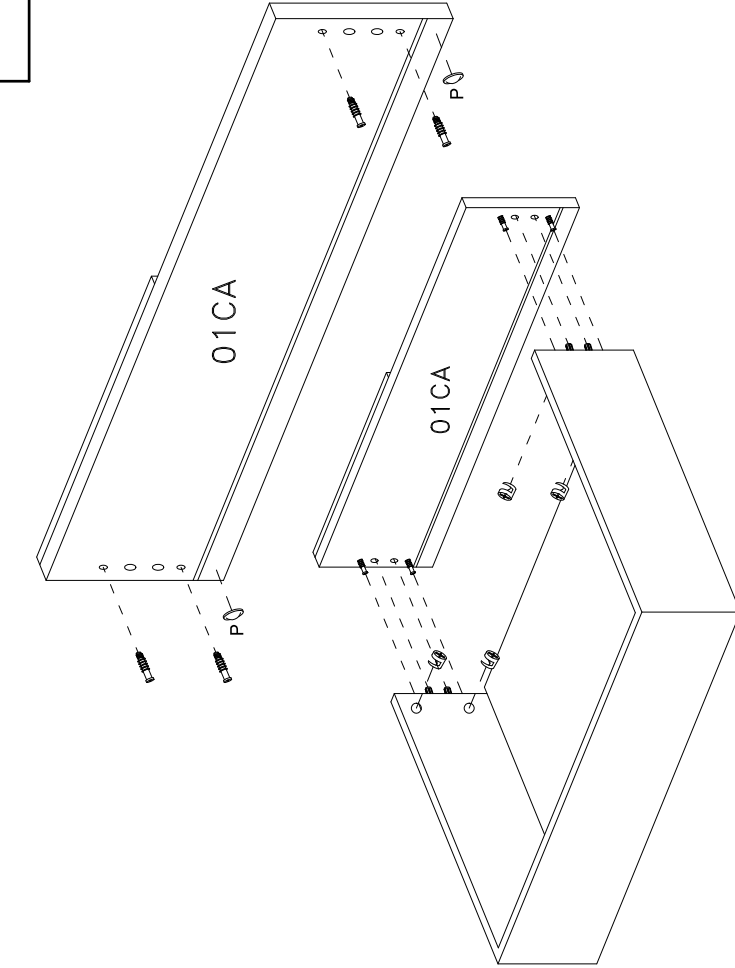
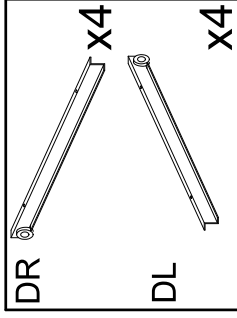
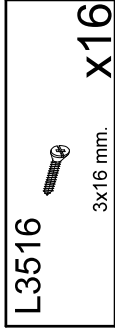
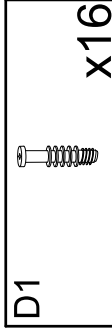
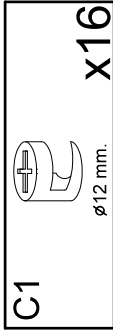
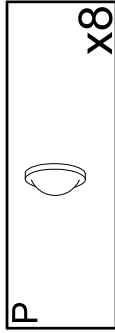
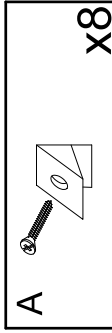
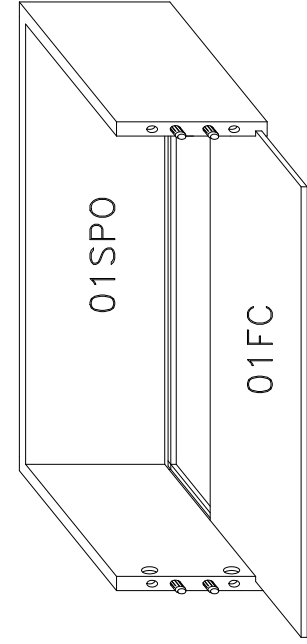

7

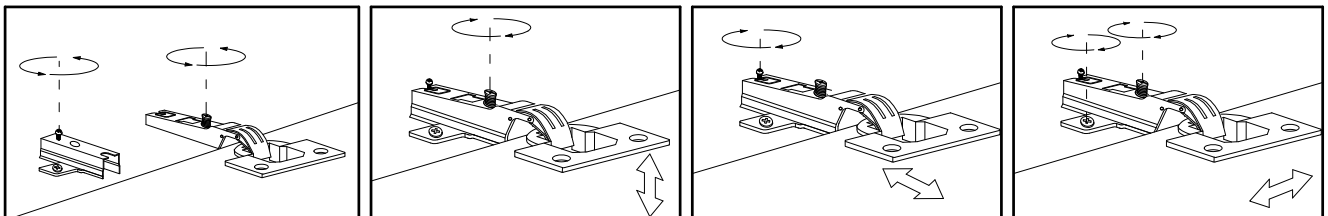
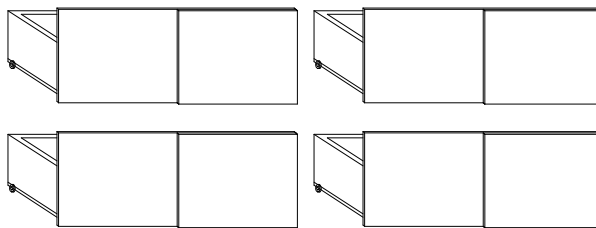
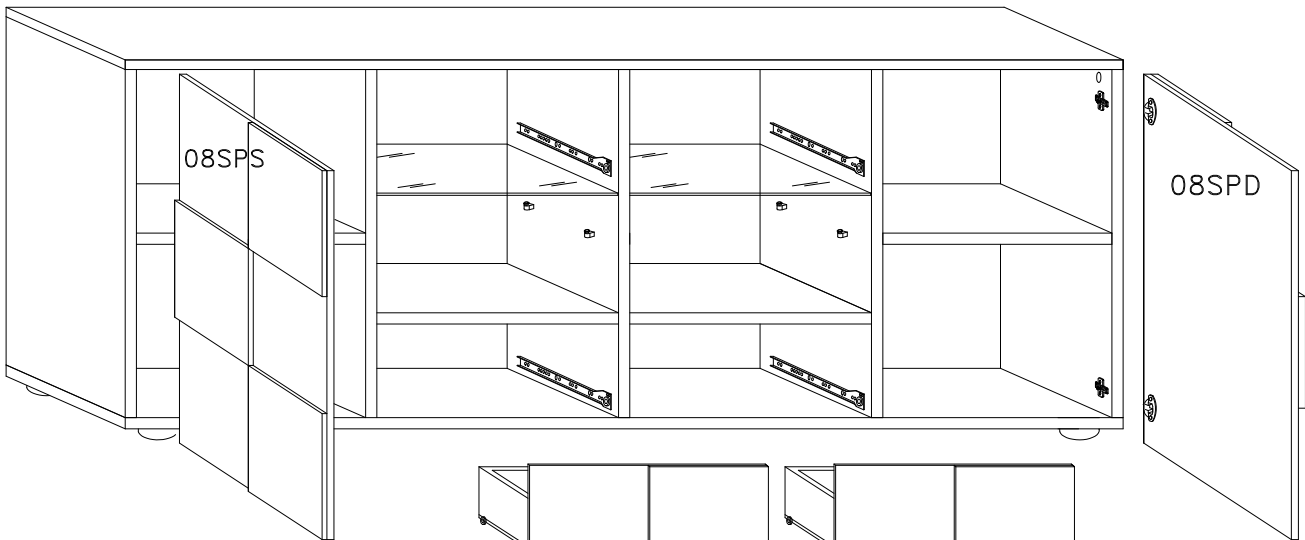
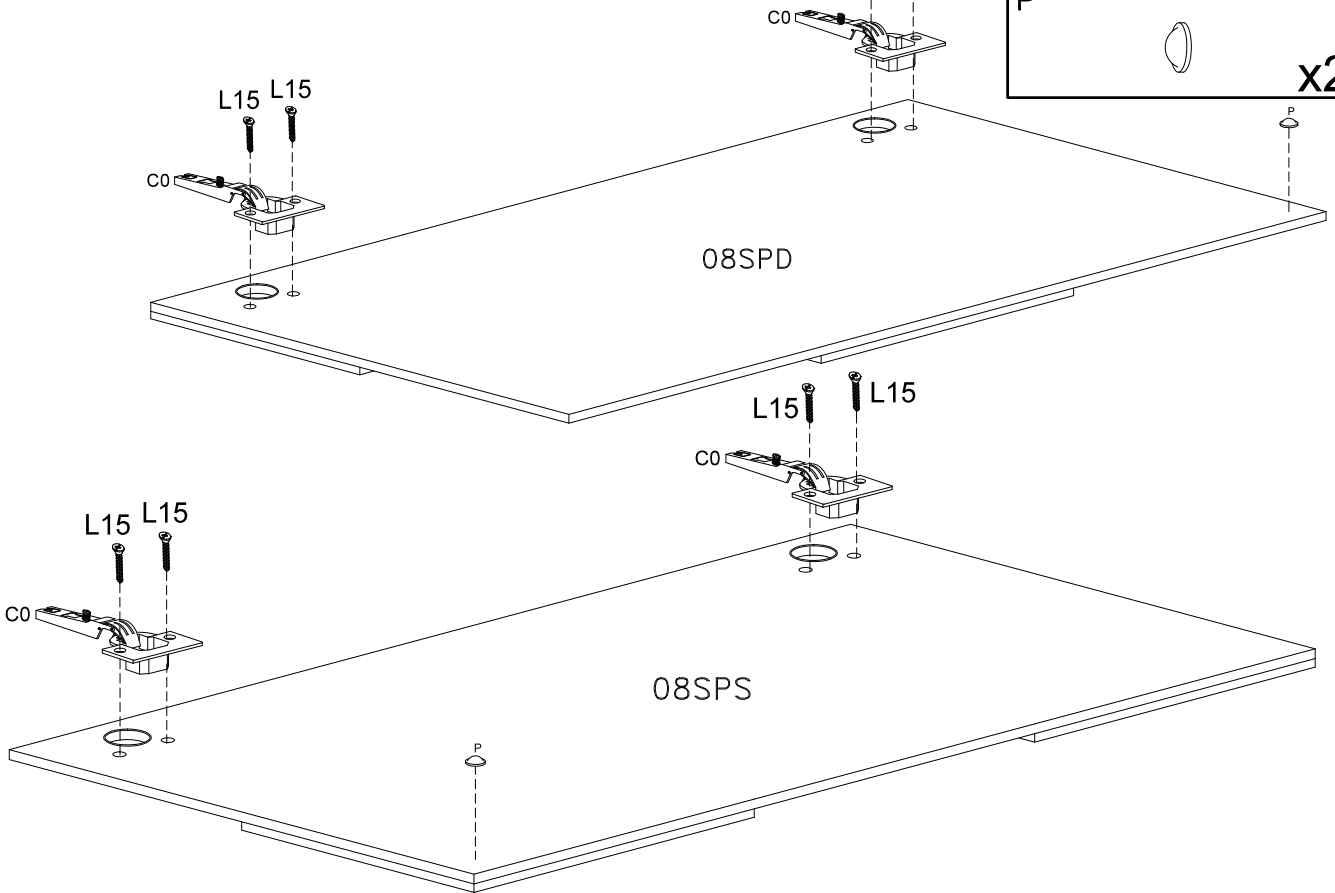
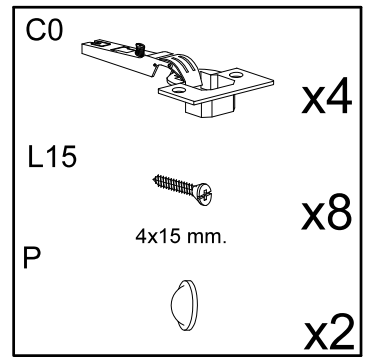
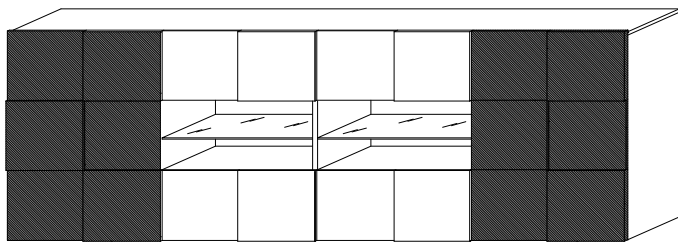

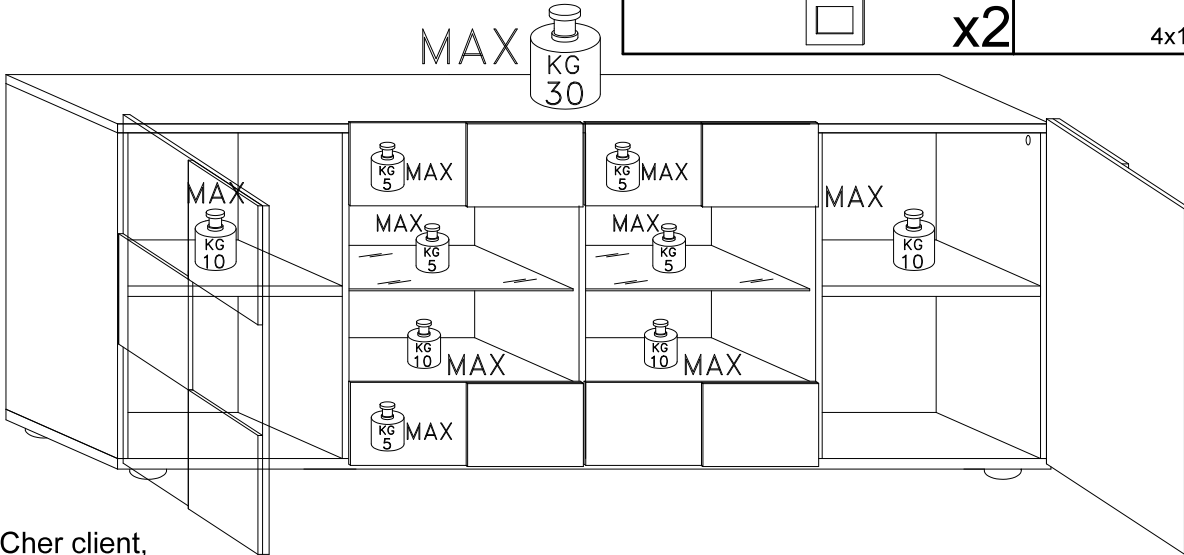
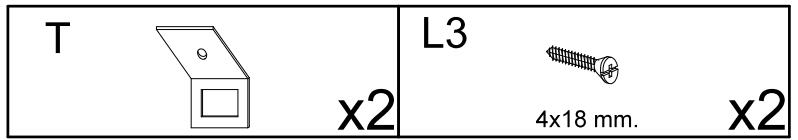

Cher client,
 l'installation des meubles suspendus doit être effectuée par un personnel compétent.
 Les fischers ne sont pas inclus dans la quincaillerie.
 Choisir les types des fischers pour le fixage apte au mur.
 S'assurer de l'adéquation du mur pour support sûr du meuble

Dear Customer

The assembling of the hanging elements must be done by a competent staff.
 The fishers are not included in the hardware package.
 Choose the fisher more suitable to the type of the wall.

Ensure the suitability of the wall for a secure support of the hanging element.

Sehr geehrter Kunde, die Montage der Haengeelemente muss von Fachpersonal ausgefuehrt werden! Bitte verwenden Sie eigene, der Beschaffenheit der Wand entsprechende Duebel. Zu Ihrer eigenen Sicherheit legen wir dem Beschlagbeutel keine Fischerduebel bei.

Gentile Cliente

Il montaggio dei pensili deve essere effettuato da personale competente.

I tasselli di fissaggio non sono compresi nella ferramenta.

Scegliere il tipo di tassello per il fissaggio più adatto alla tipologia di muro.

Assicurarsi l'idoneità della parete per un sostegno sicuro del pensile.

