

# -07P2

Montageanweisung / Installation instructions / Instruction de montage / Istruzioni di montaggio  
montagehandleiding / Instrukcja montażu / Montaj talimatlar / Osszeszerelési útmutató / Nàvod k montáži /  
Nàvod na montáž / Instrucțiune de montaj / Инструкция по монтажу / Montaj talimatina / Monteringsanvisningar  
Upute za montažu / Instrucciones de Montaje / Navodila za montažo

# BASIC

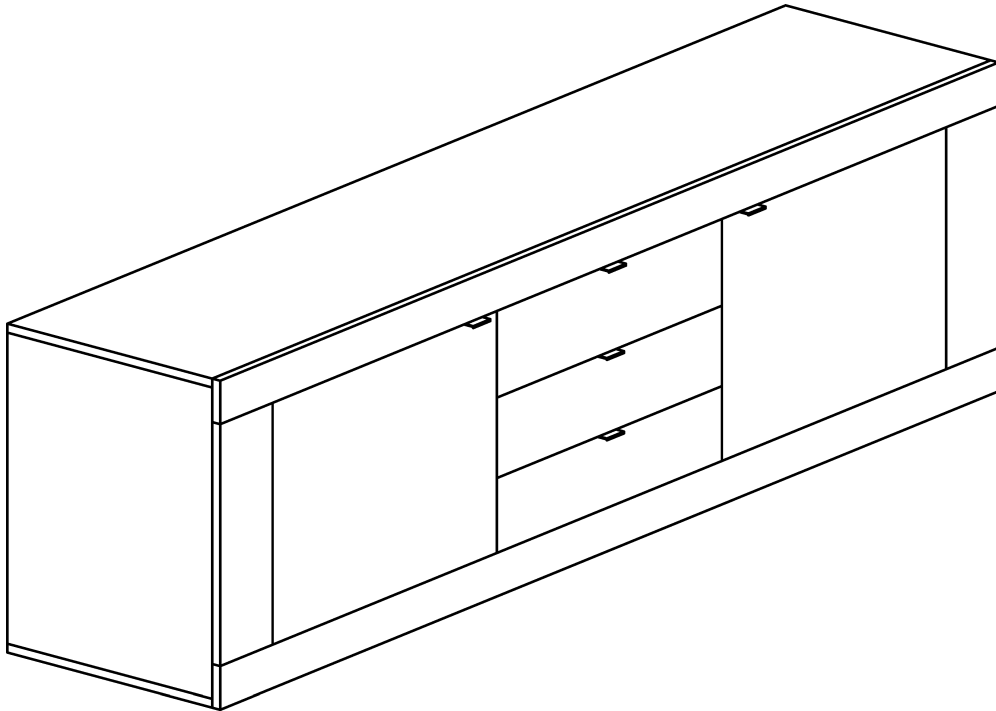
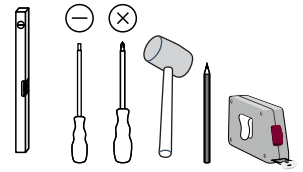
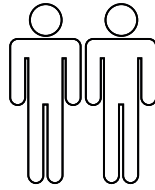
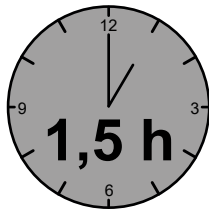

LC S.p.A  
Via del Piano s.n  
61030 Isola del Piano  
(PU) Italia  
<http://www.lcmobili.com>



**LE TRI**  
**+ FACILE**



**D** – bitte lesen sie diese montageanleitung gut durch,  
Da wir für fehler, die durch falsche montage entstehen,  
Keine haftung übernehmen!

**Gb** – please read these installation instructions  
Through carefully as we cannot accept any liability  
For faults occurring as a result of incorrect installation!

**Cz** – přečtěte si prosim pozorně tento návod k montáži,  
Aby jste předešli chybám vzniklých špatnou montáží,  
Za které neručíme!

**F** – veuillez lire attentivement cette notice de montage,  
Car nous déclinons toute responsabilité en cas d'erreurs  
Découlant d'un montage erroné !

**I** – prego leggere attentamente le istruzioni per il montaggio,  
Poiché decliniamo qualsiasi responsabilità  
Per difetti derivanti da montaggio errato.

**S** - läs monteringsanvisningarna noggrant.  
Vi avsäger oss allt ansvar för defekter som  
Uppstår p.g.a. Felaktig montering.

**Hr** – pažljivo pročitajte upute za montažu,  
Jer otklanjamo svaku odgovornost za pogreške  
Nastale uslijed pogrešne montaže.

**Slo** – prosimo, da pozorno preberete navodila za montažo,  
Saj zavračamo vsakršno odgovornost za napake,  
Ki bi nastale zaradi napačne montaže.

**NI** – leest u alstublieft deze montagehandleiding goed door,  
Voor fouten door verkeerde montage zijn wij niet verantwoordelijk.

**Pl** – prosze uwaznie zapoznac sie z instrukcja montazu,  
Poniewaz nie ponosimy odpowiedzialnosci za niewlasciwy montaz.

**HU** – Kérjük, olvassa el figyelmesen  
ezt az összeszerelési útmutatót,  
mert a helytelen összeszerelésből  
a dódó hibákért nem vállalunk felelősséget!

**SK** – Prosime, dobre prečítajte si tento návod na montáž,  
pretože nepreberáme žiadne ručenie za chyby,  
ktoré vzniknú na základe chybnej montáže!

**RO** – Vă rugăm să cititi cu atenție aceste instrucțiuni  
de montaj deoarece nu preluăm garanția pentru defecte  
ce apar datorită unui montaj incorect!

**RUS** – Пожалуйста, внимательно ознакомьтесь ù  
с данной инструкцией по монтажу, поскольку мы не  
несем ответственности за ошибки, причиной которых  
является неправильный монтаж.

**TU** – İlkonce kullanma klavuzunu iyi okuyun,  
yalnis montaj yapasaniz bunun sorumlusu biz degiliz.

**ES** – Se ruega leer con atención las instrucciones  
de montaje debido a que declinamos cualquier  
responsabilidad  
por defectos derivados de un montaje erróneo.

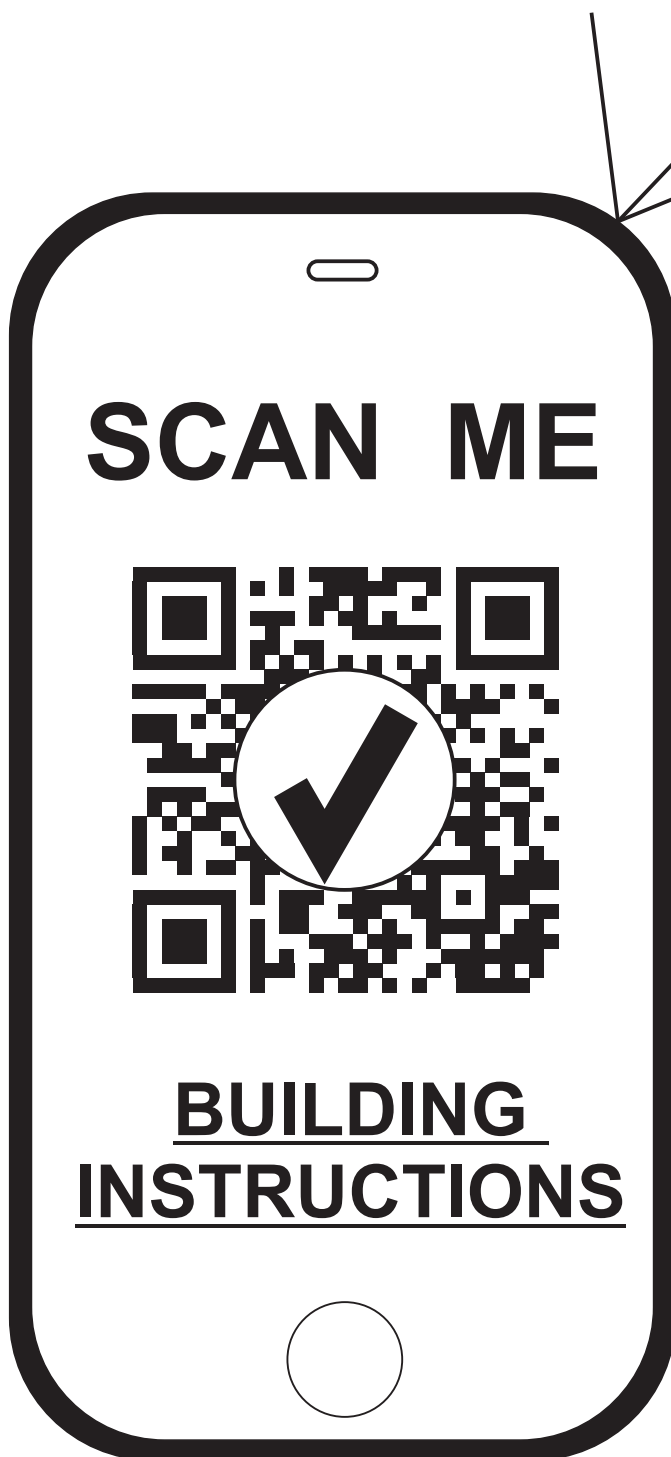



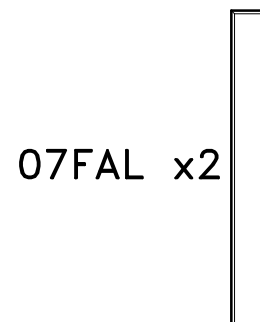
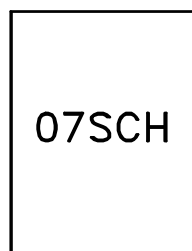
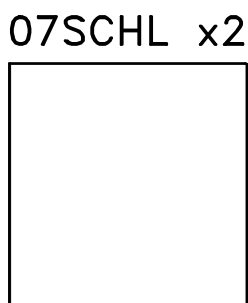
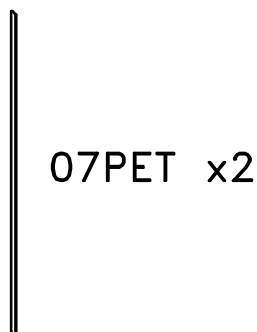
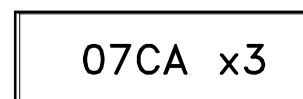
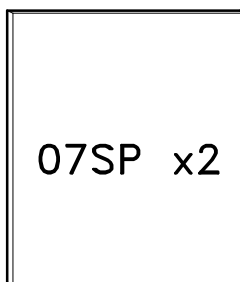
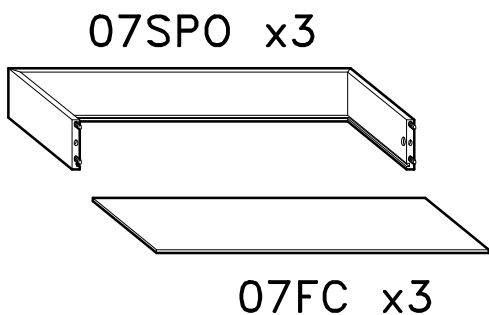
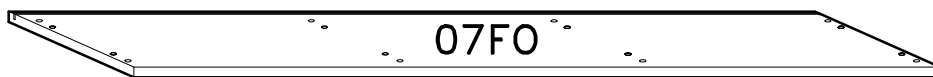
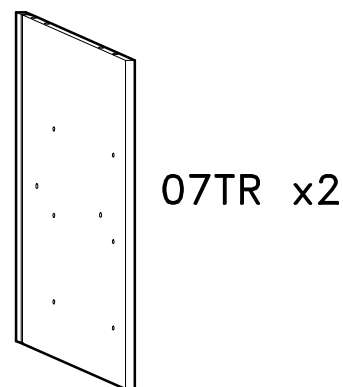
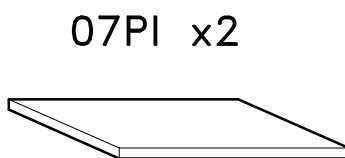
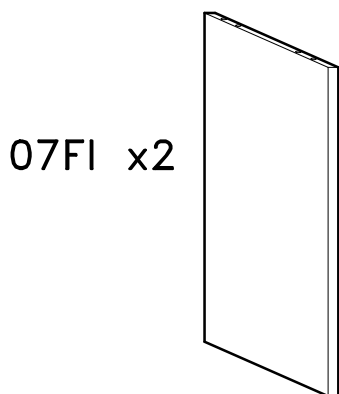
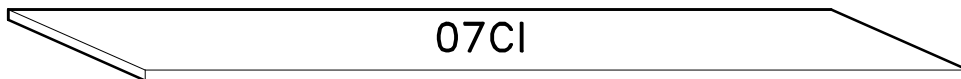
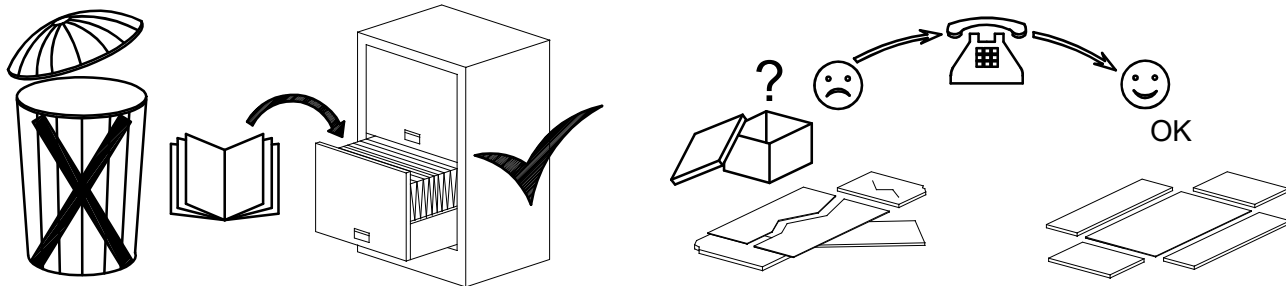





# SERVICEKARTE

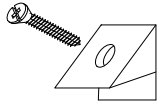

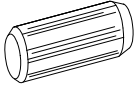

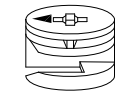
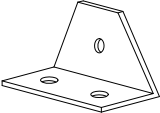
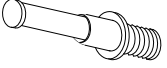
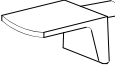
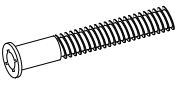
07FASI x2



**ONDERDELEN LYST-SERVICEKARTE-FORMULAIRE DEMANDES SAV-SPAREPARTS LIST-SCHEDA DI SERVIZIO**  
**BESLAG-BESCHLAEGE - QUINCALLERIE - HARDWARE - FERRAMENTA**

201502-07CF

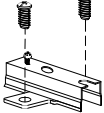
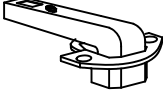

<b>A</b>		<b>x30</b>	<b>M11</b>		<b>x12</b>
				6x11 mm.	
<b>B</b>		<b>x24</b>	<b>P</b>		<b>x8</b>
	8x30 mm.				
<b>C</b>		<b>x12</b>	<b>P7</b>		<b>x12</b>
	Ø15 mm.				
<b>D</b>		<b>x12</b>	<b>R</b>		<b>x8</b>
<b>E</b>		<b>x4</b>	<b>L</b>		<b>x6</b>
	7x60 mm.			4x30 mm.	
<b>M2</b>		<b>x12</b>	<b>L3</b>		<b>x36</b>
	3.5x16 mm.			4x18 mm.	

<b>M2</b>		<b>x10</b>
	3.5x16 mm.	
<b>S11</b>		<b>x5</b>

<b>L2</b>		<b>x8</b>
	4x15 mm.	
<b>N1</b>		<b>x4</b>
<b>O1</b>		<b>x4</b>

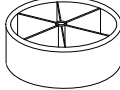
<b>C1</b>		<b>x6</b>
	Ø12 mm.	
<b>D1</b>		<b>x6</b>

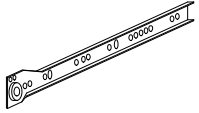
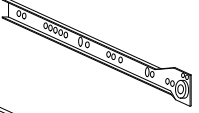
<b>F21</b>		<b>x6</b>
	Ø 60 mm h 20 mm	

<b>CL</b>		<b>x3</b>
<b>CR</b>		<b>x3</b>
<b>DR</b>		<b>x3</b>
<b>DL</b>		<b>x3</b>

**OPTIONAL**

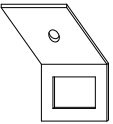
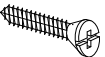
<b>T</b>		<b>x1</b>
<b>L3</b>		<b>x1</b>
	4x18 mm.	



2

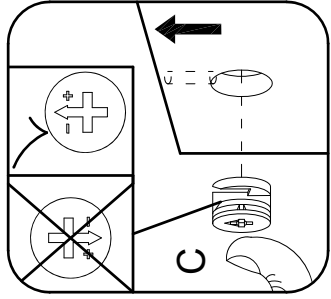
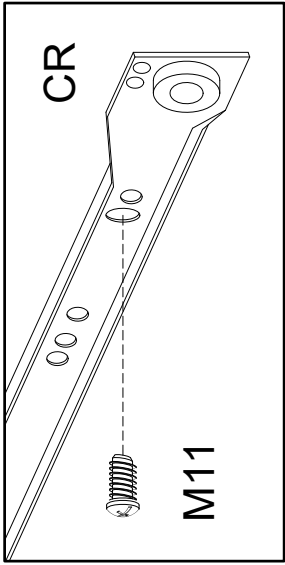
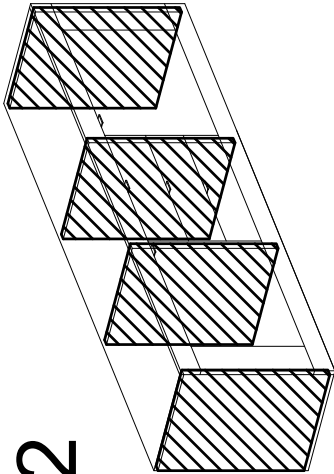

x16



x12

CL



x3

CR



x3

M11



6x11 mm. x12

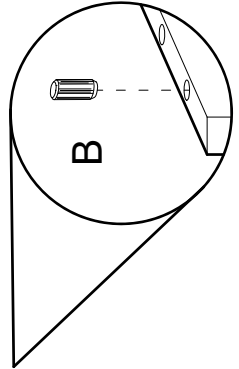
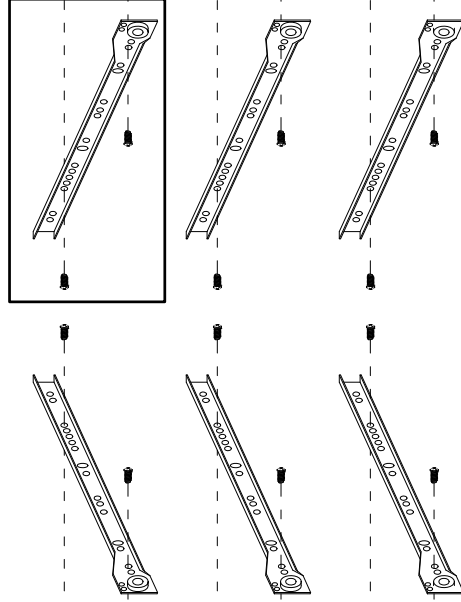
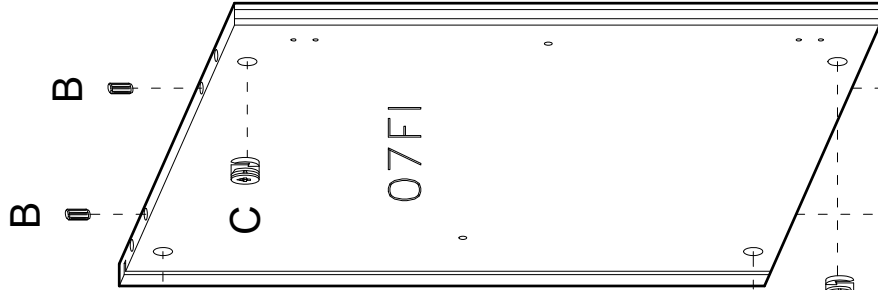
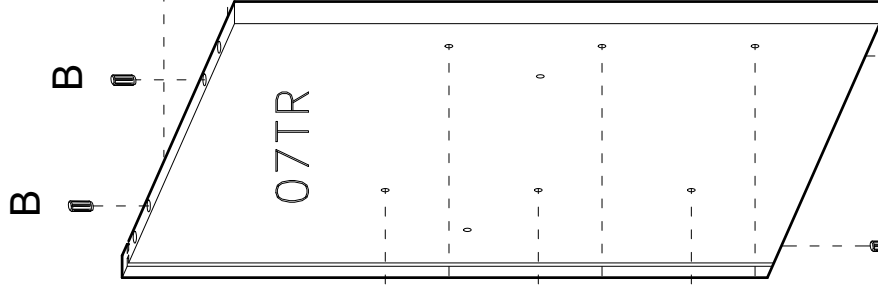
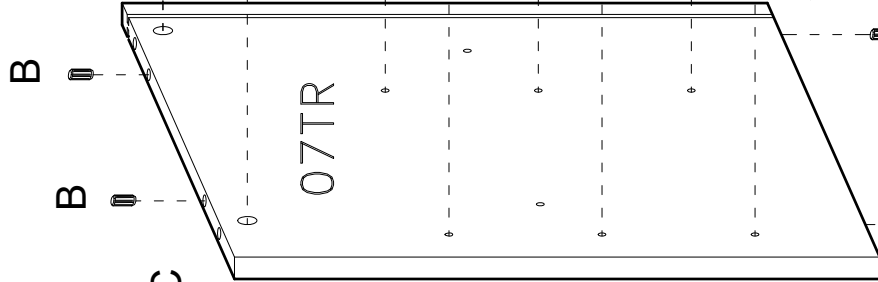
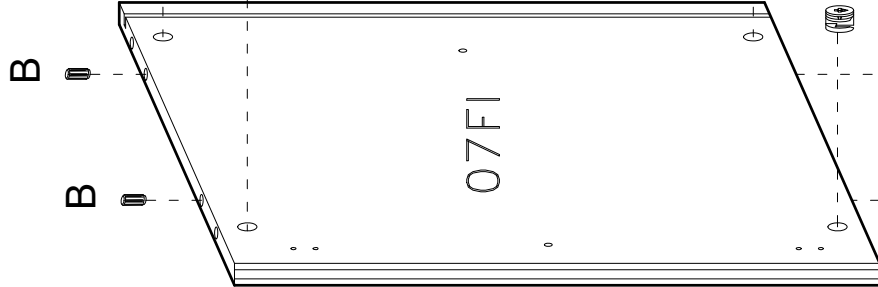

3

E



x4

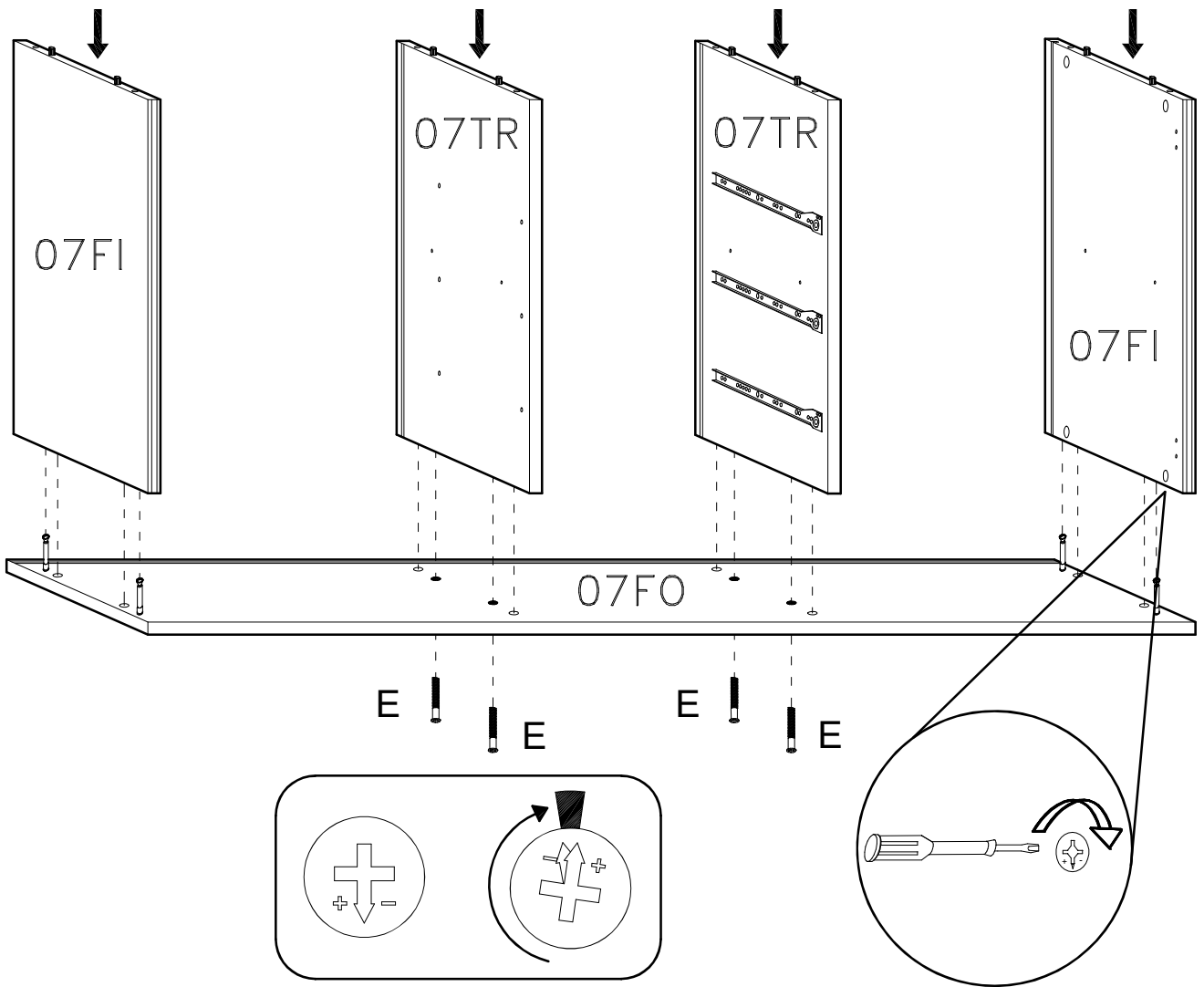

4

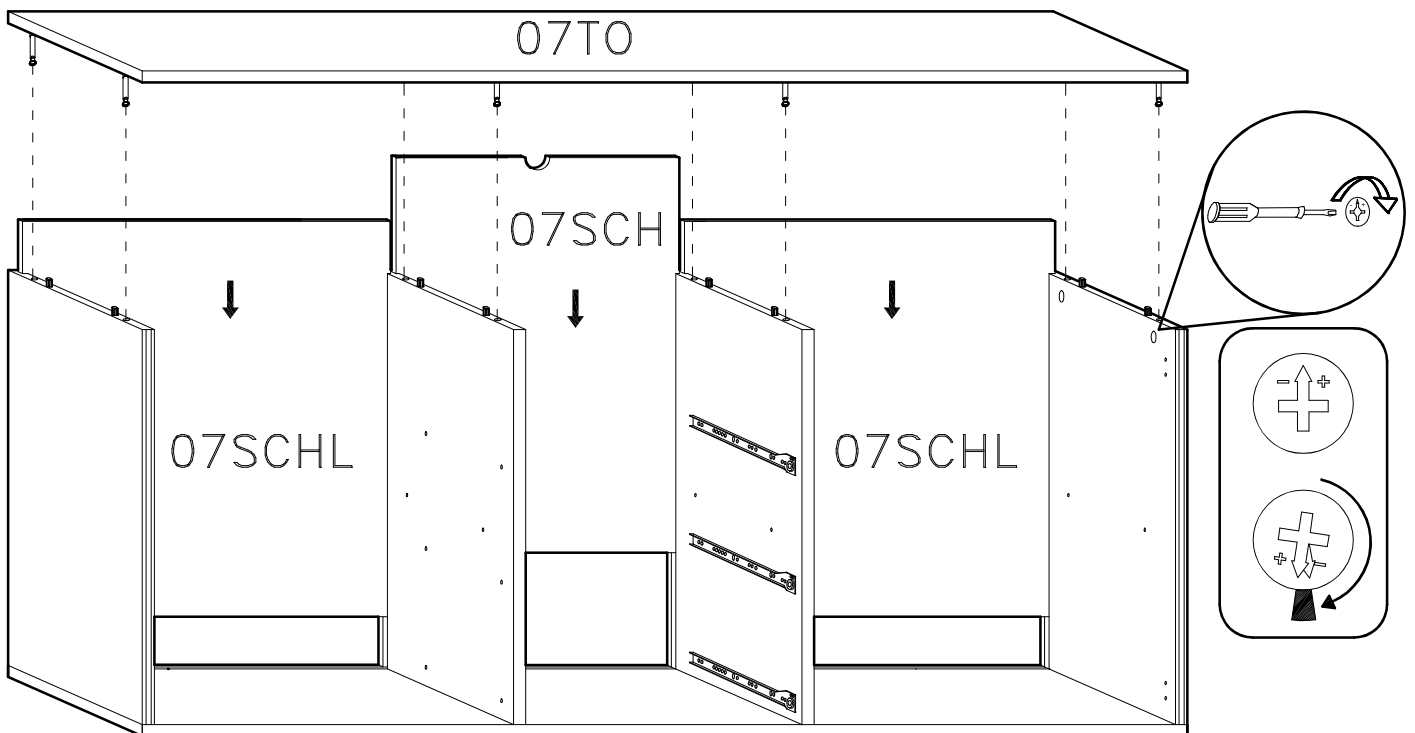

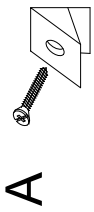
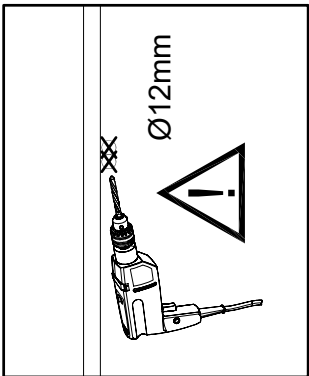
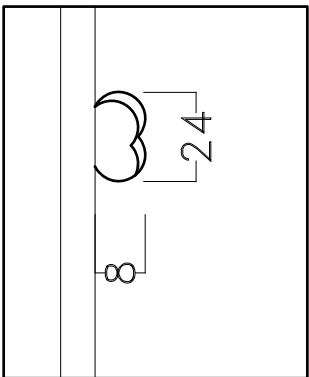



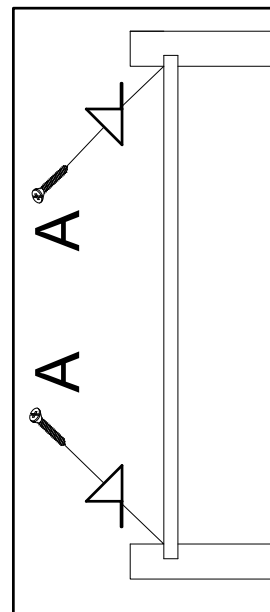
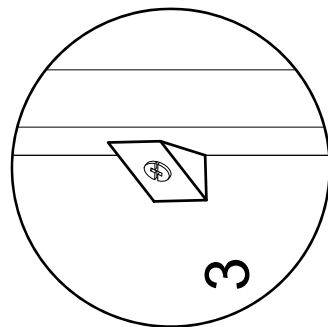
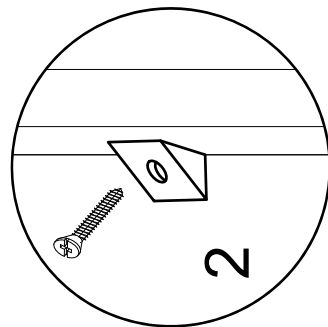
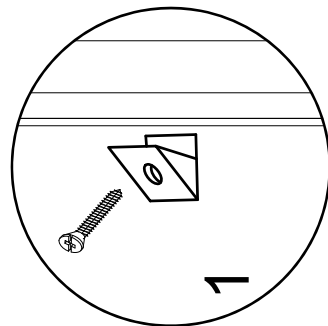
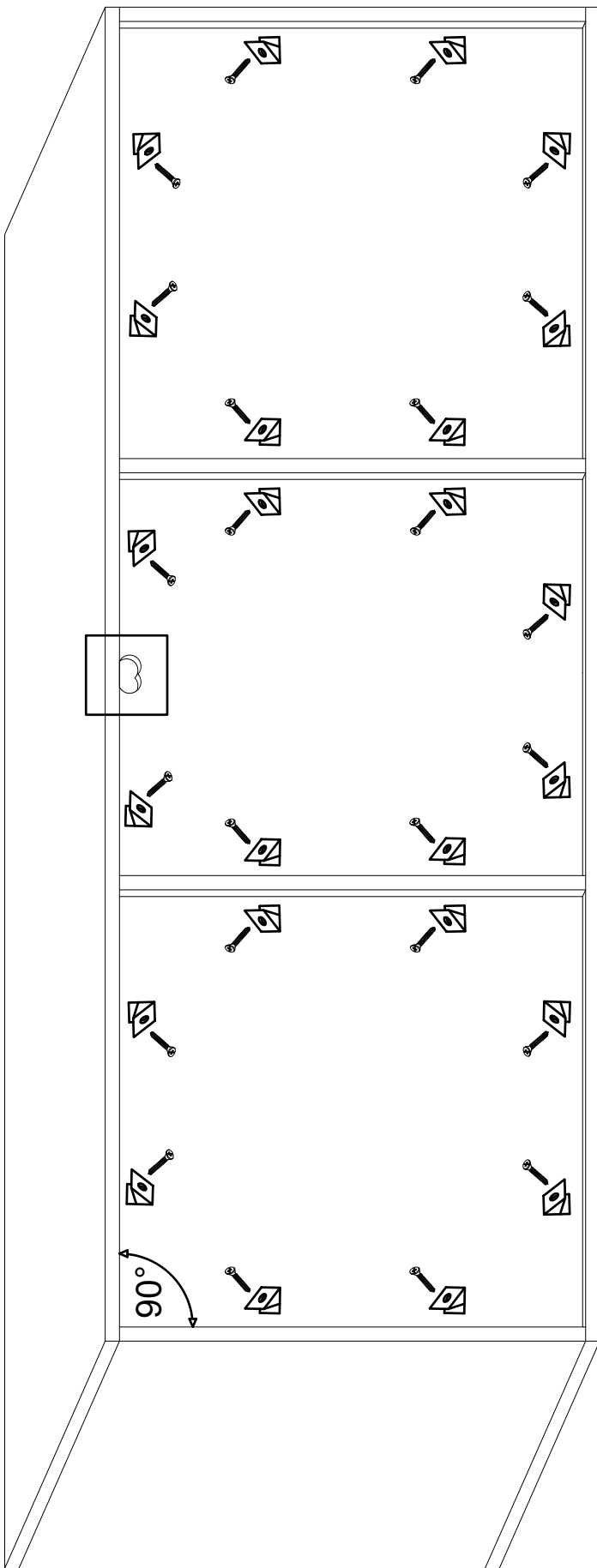

x24

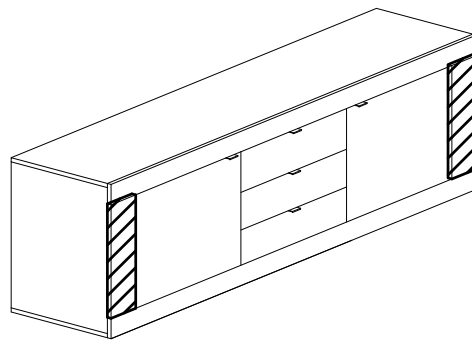
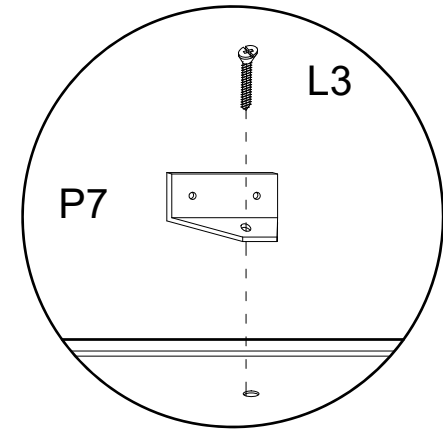

6



- B  8x30 mm. x8
- L3  4x18 mm. x4
- N1  x4
- P7  x4

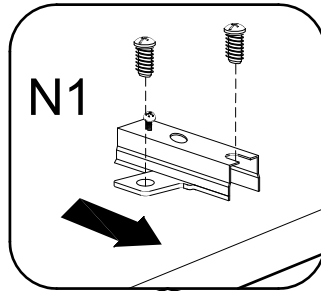

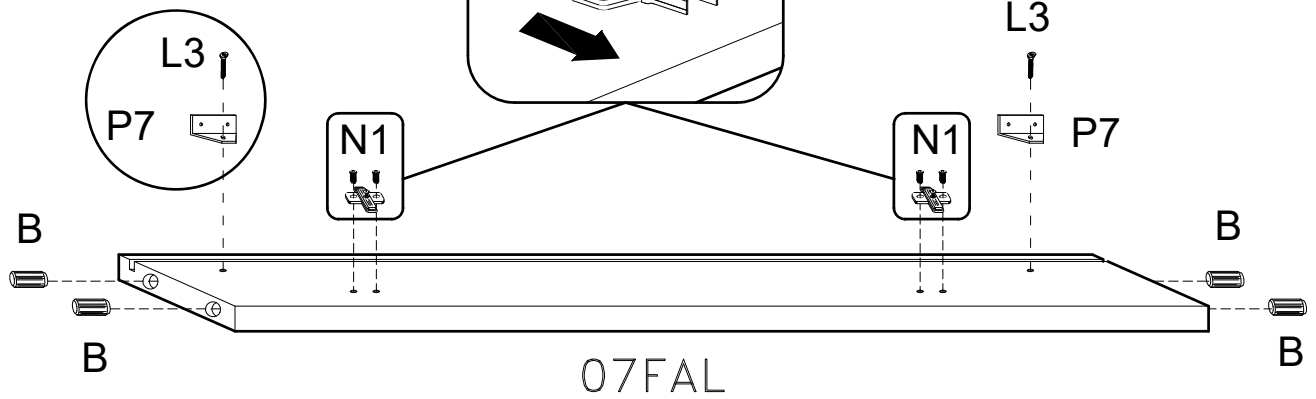

x2

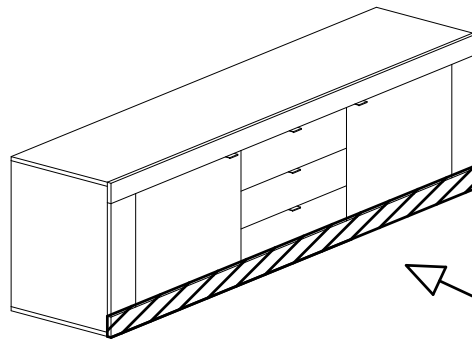
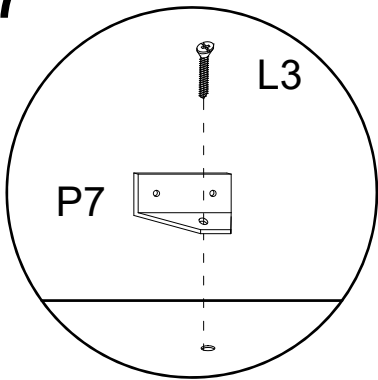

7



- L3  4x18 mm. x4
- P7  x4

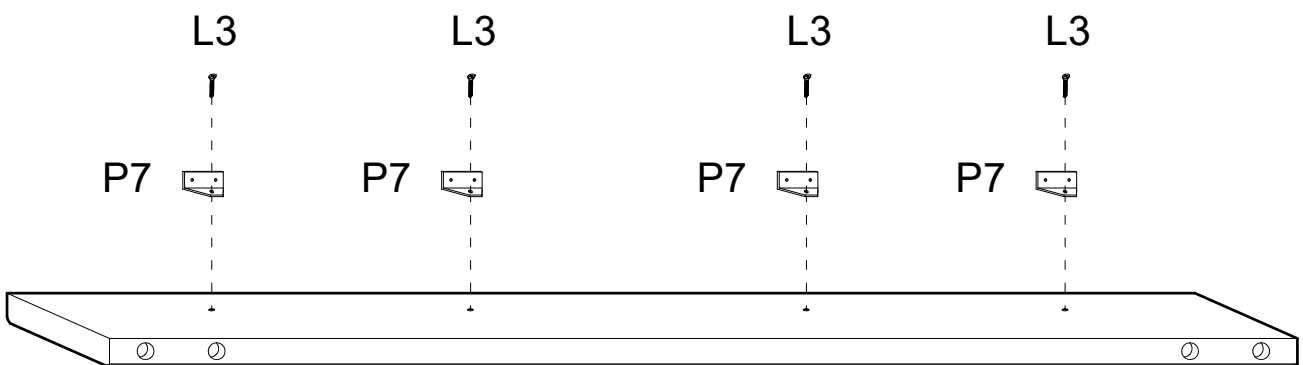

07FASI

8

R



x8

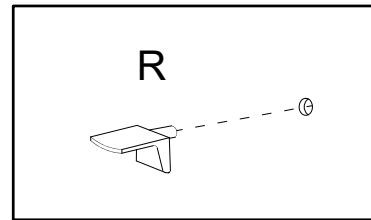
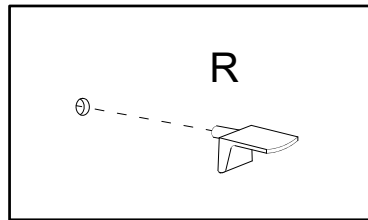
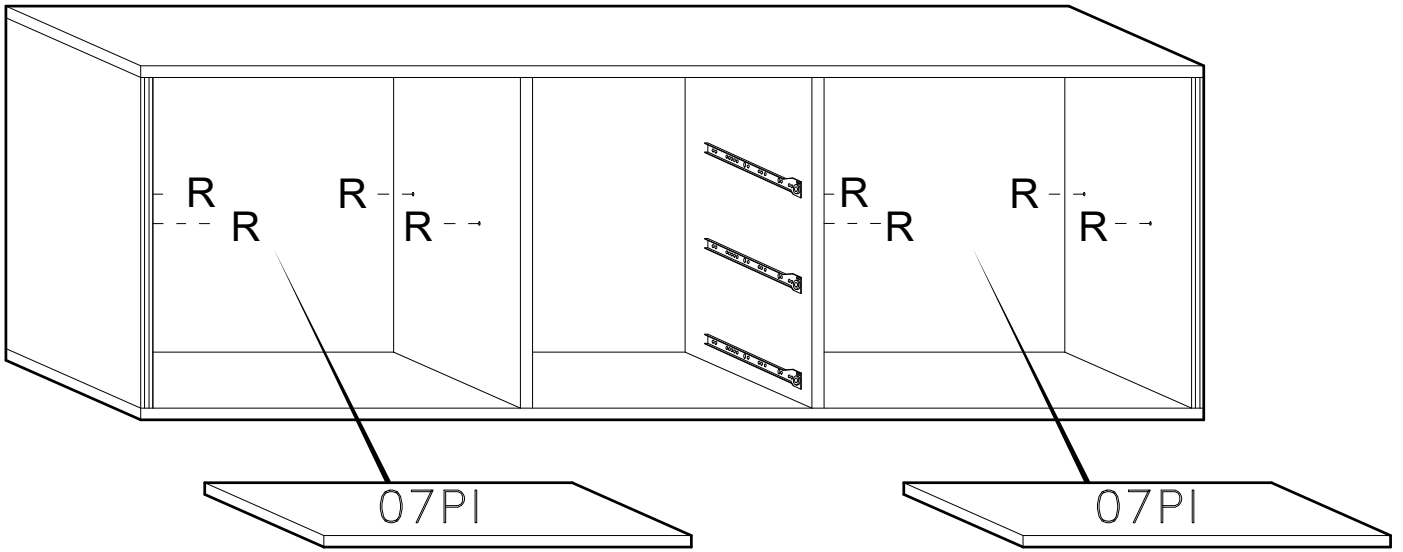

9

L3



4x18 mm.

x8

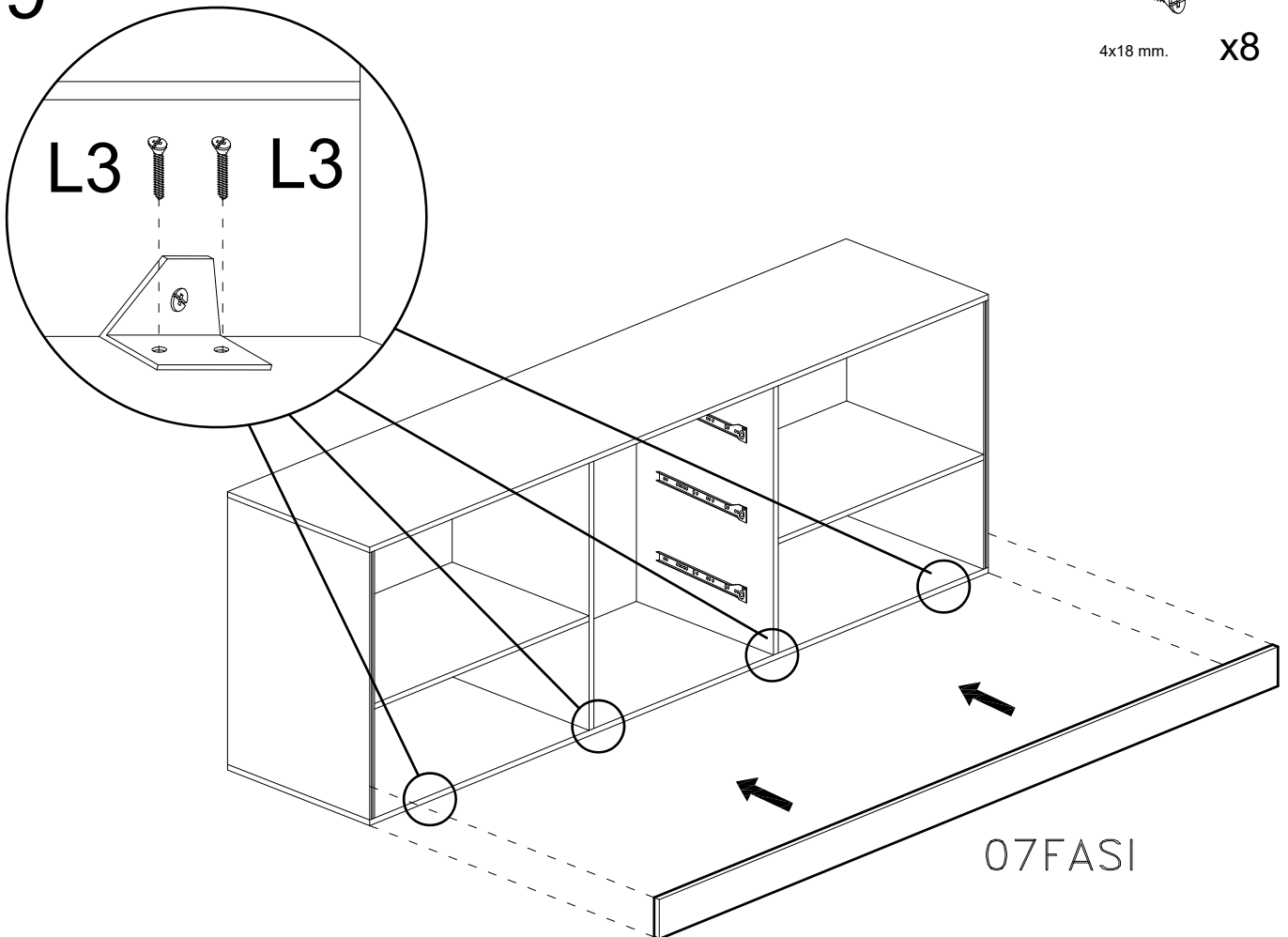

10

L3



X8

4x18 mm.

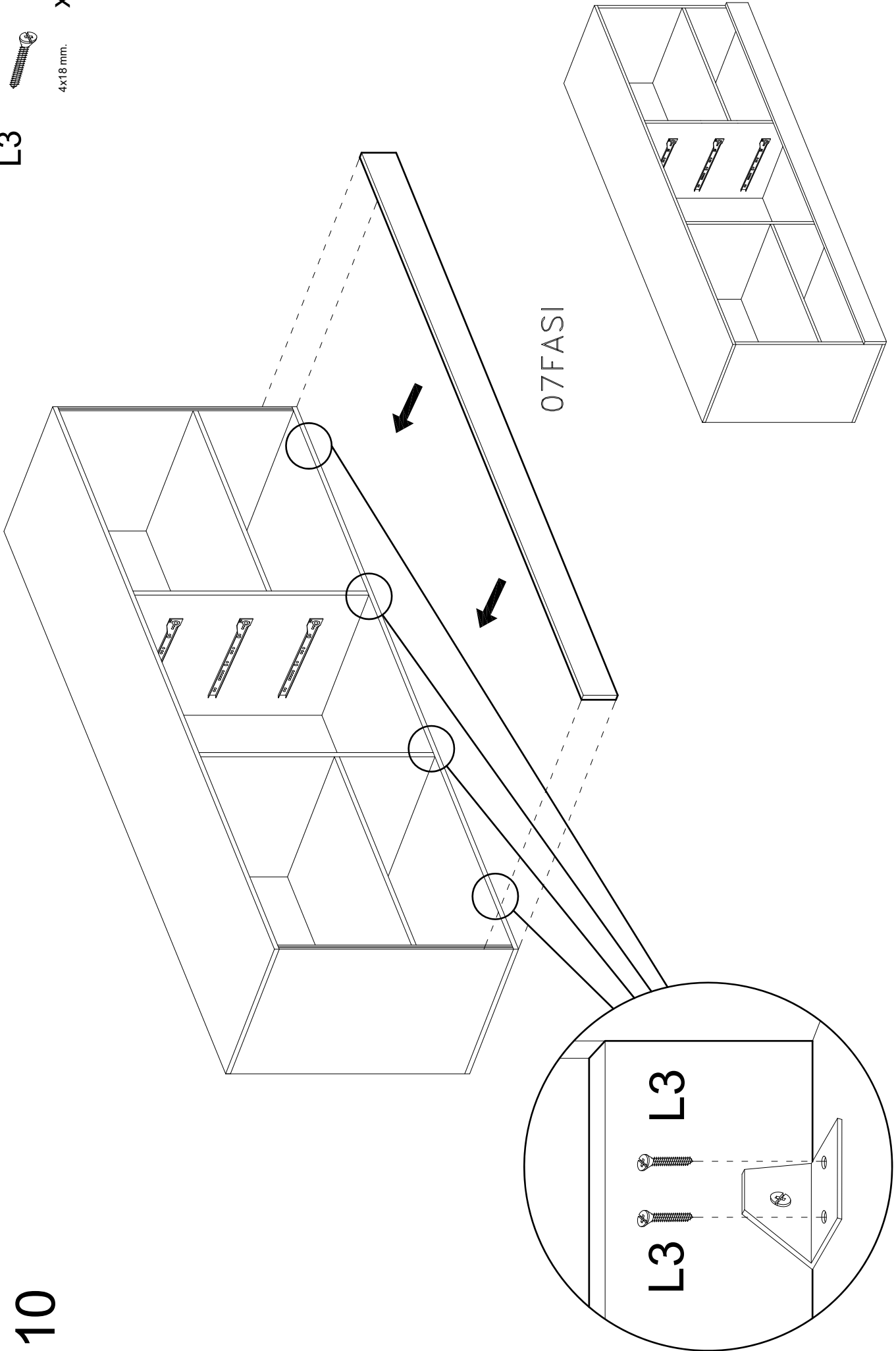

L3



4x18 mm.

x8

10

07PET

07FAL

07FAL

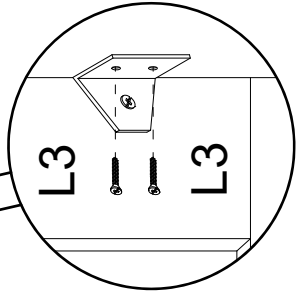

L3

L3

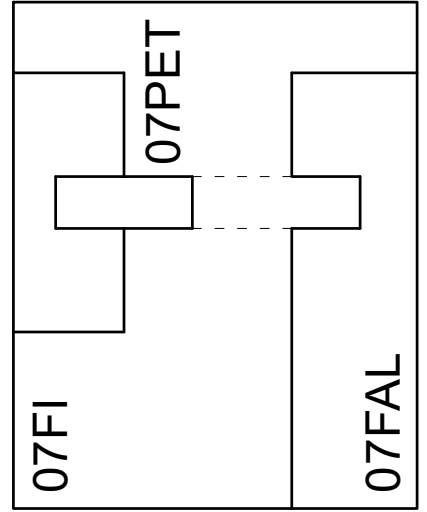

07FI

07PET

07FAL

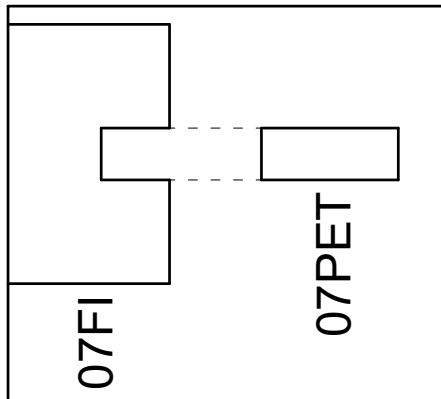

07FI

07PET

11

- L3
- P7
- 4x18 mm.
- x12
- x4

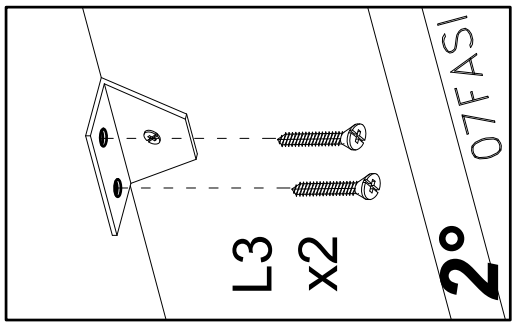
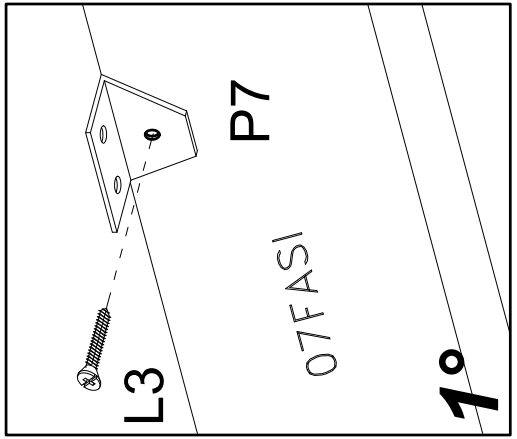
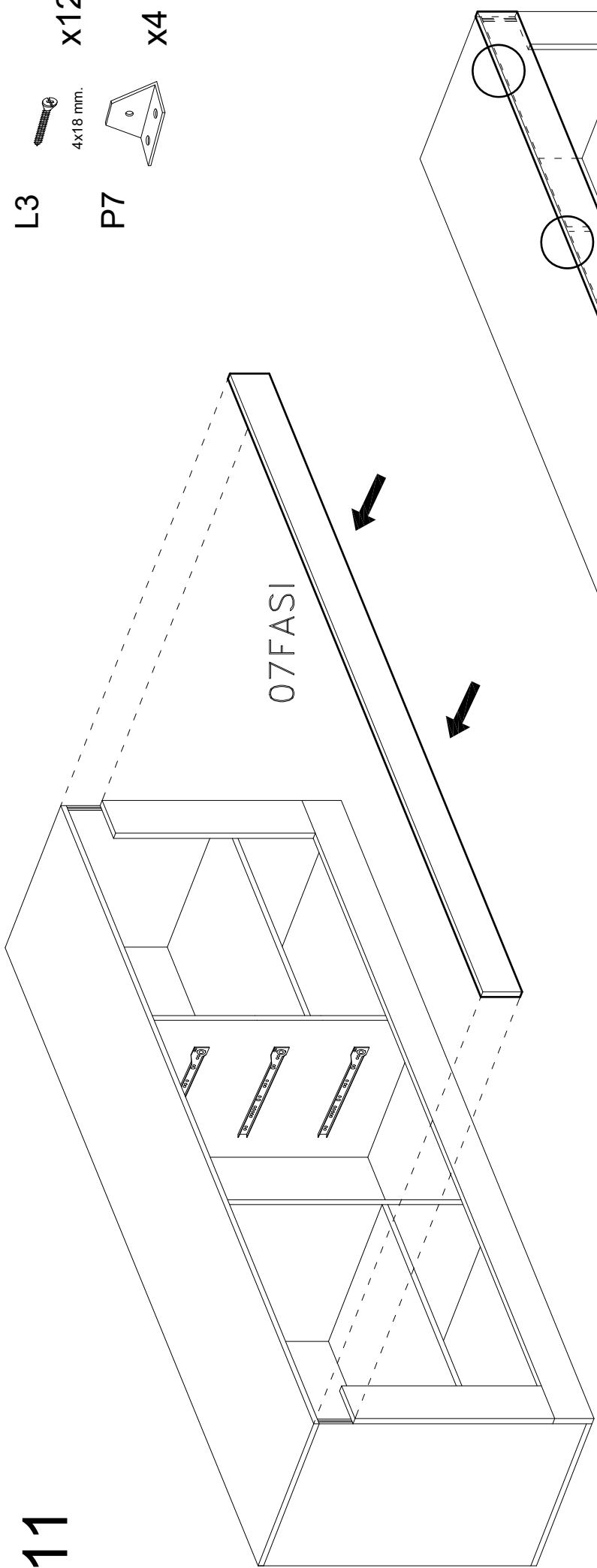



Mobili per l'Europa



**Attenzione!!! Aprire le cerniere prima del montaggio**  
**Attention!!! Open hinges before assembly**  
**Achtung!!! Scharniere vor der Montage öffnen**  
**Attention!!! Ouvrir les charnières avant l'assemblage**  
**Atención!!! Abrir las bisagras antes del montaje**

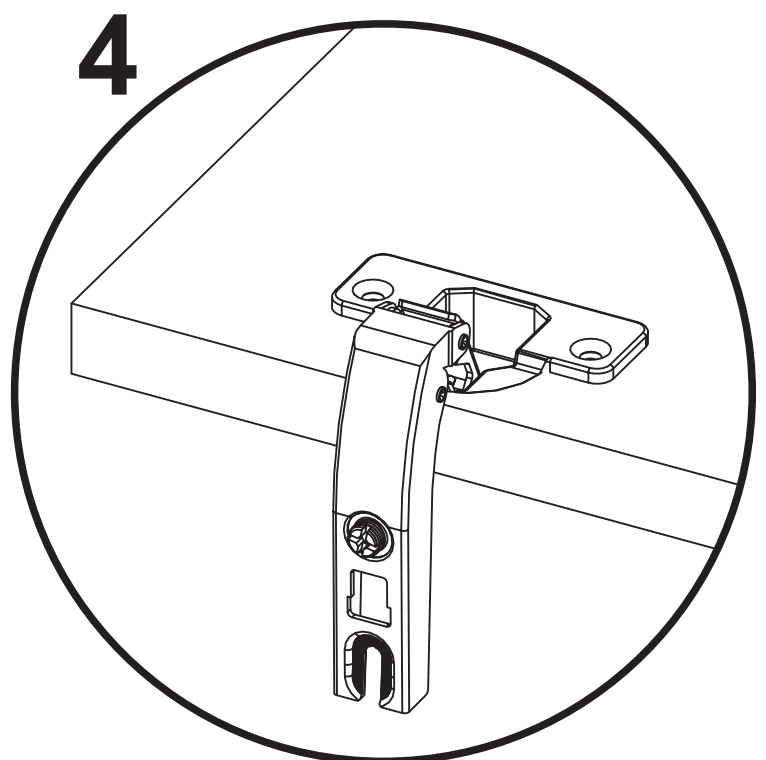
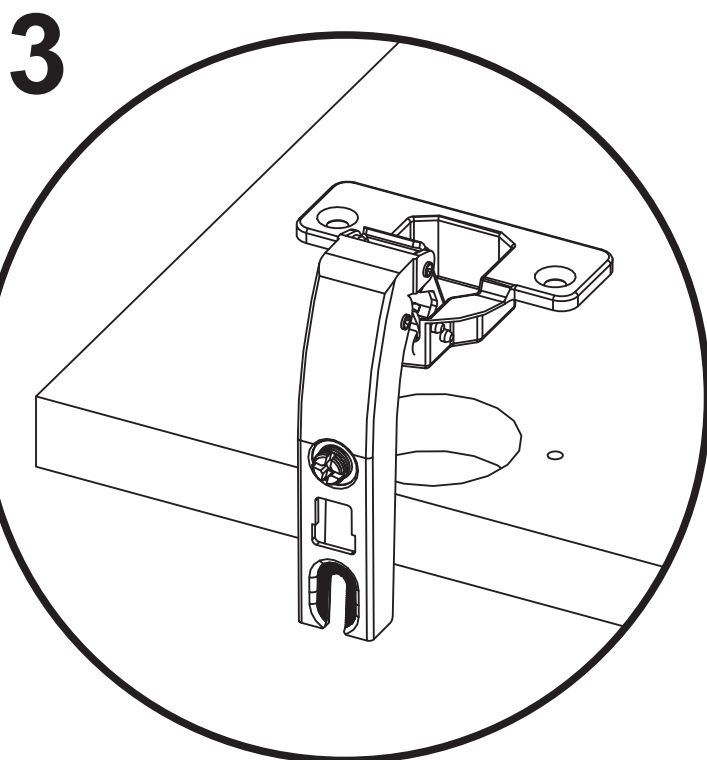
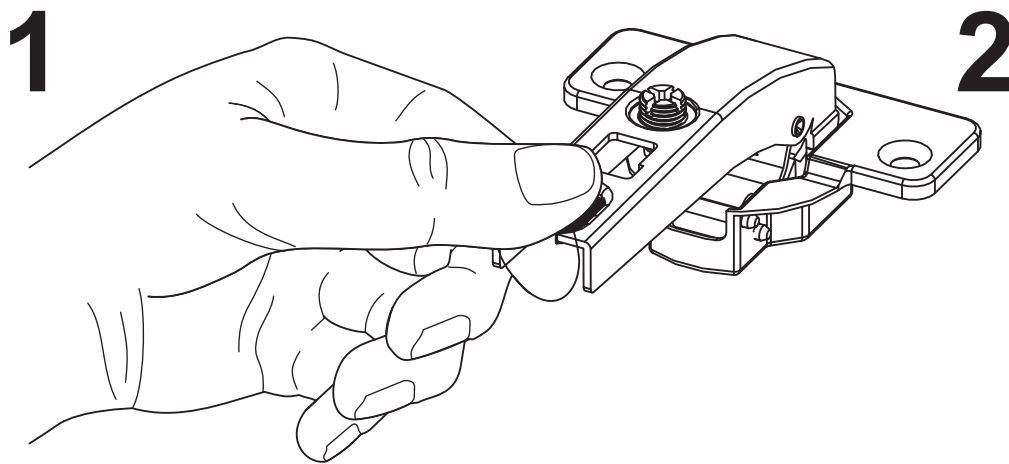

# 12

L2  4x15 mm. x8

M2  3.5x16 mm. x4

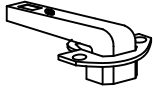
O1  x4

S11  x2

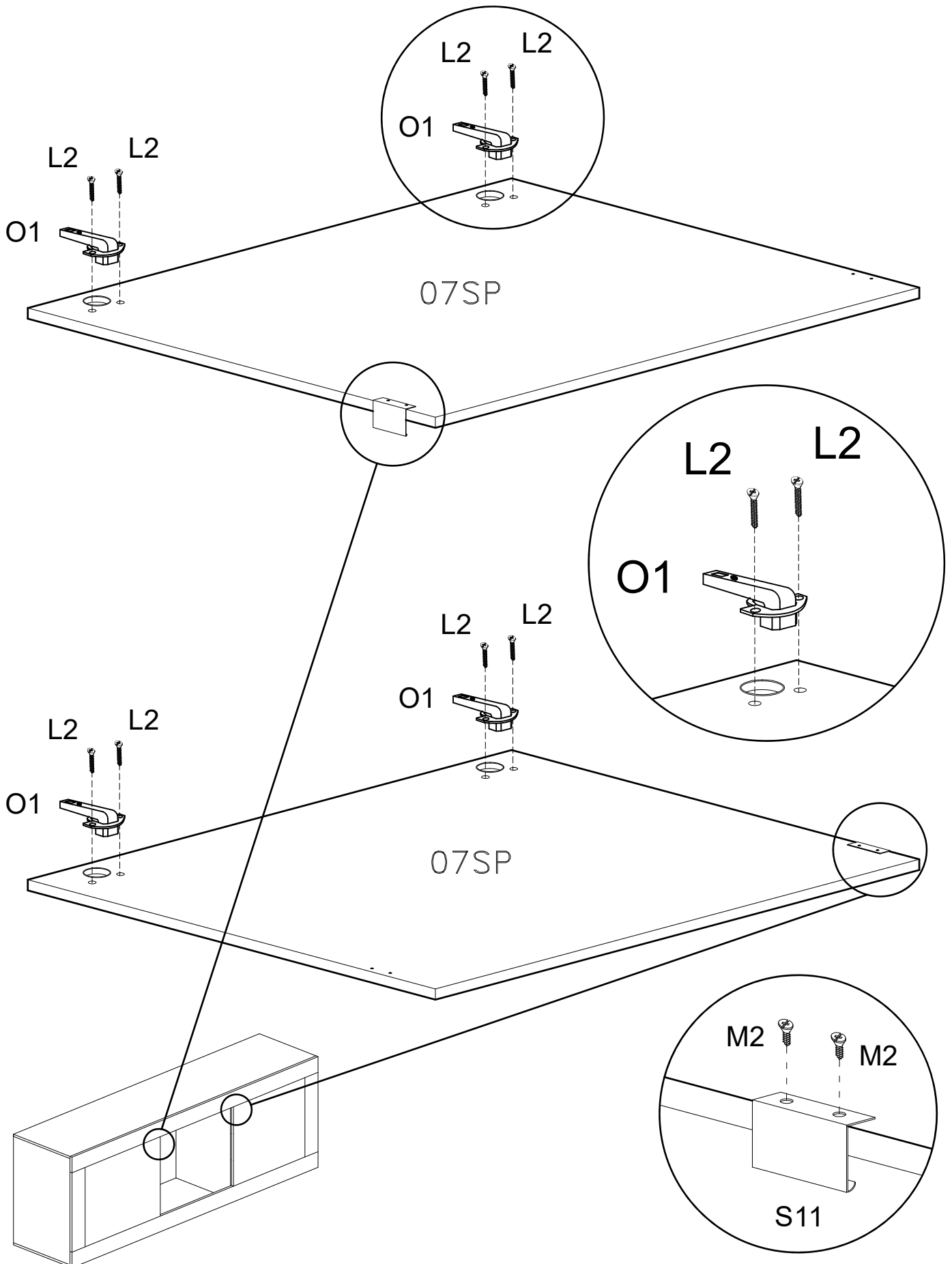

13

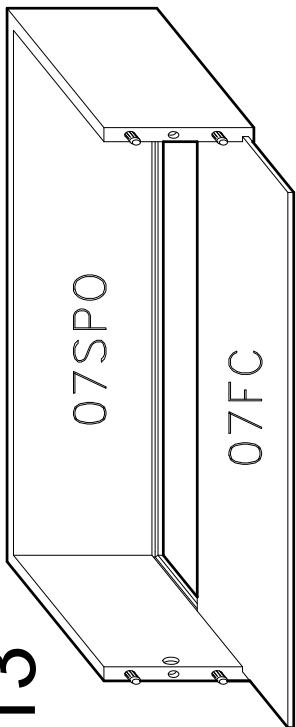

1

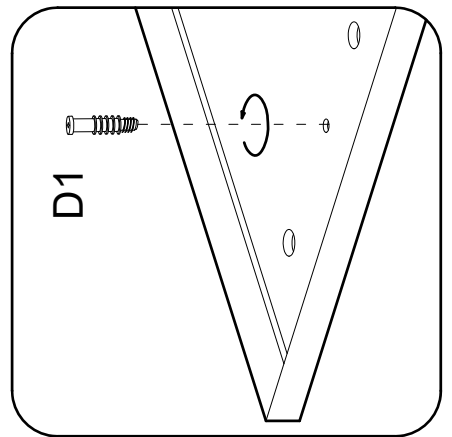
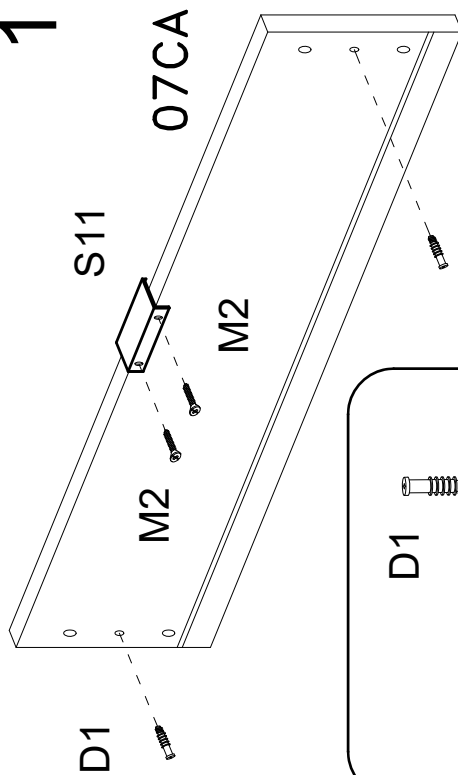

S11



x3

F



x6

M2



x18

3.5x16 mm.

DR

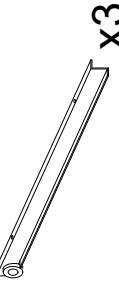

x3

C1



ø12 mm.

D1



x6

DL

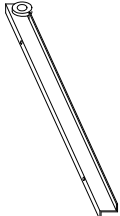

x3

X3

2

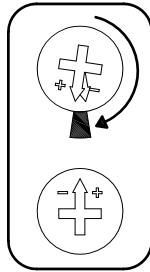
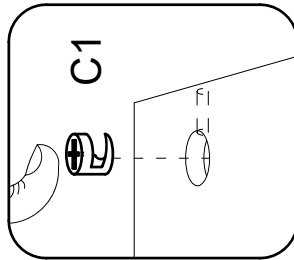
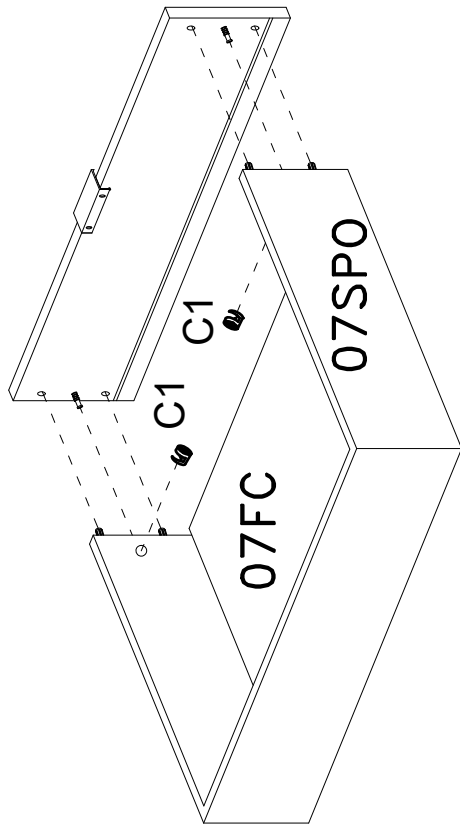

3

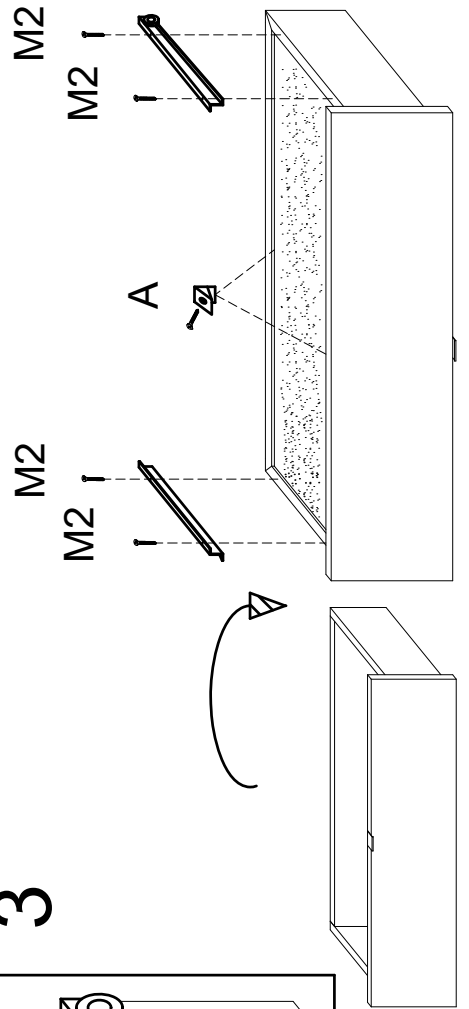
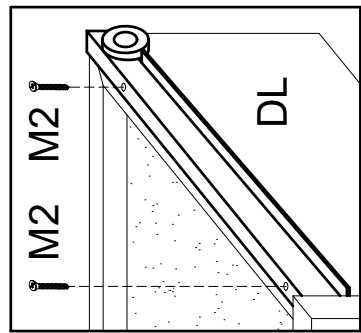

# 14

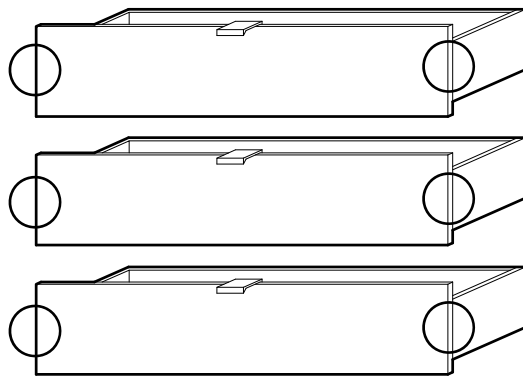
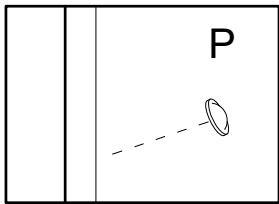
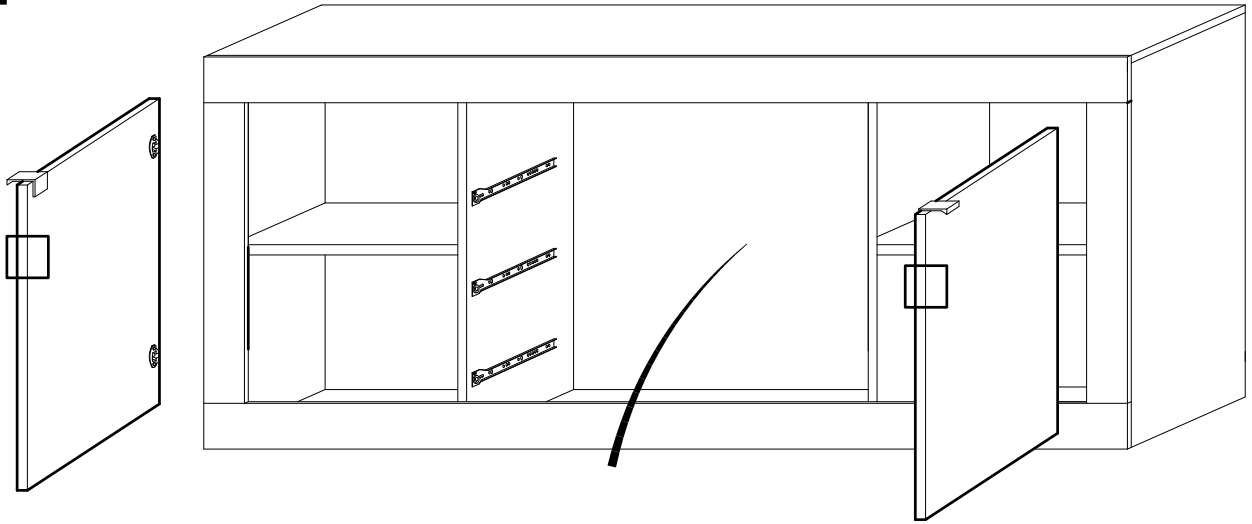

P  x8

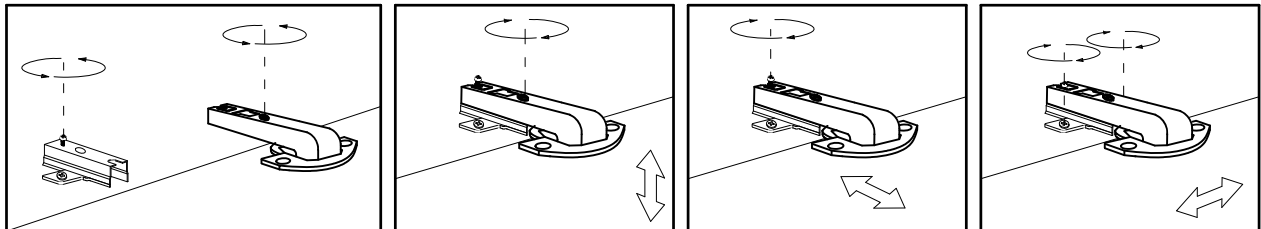
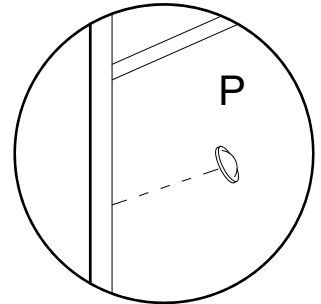

MAX

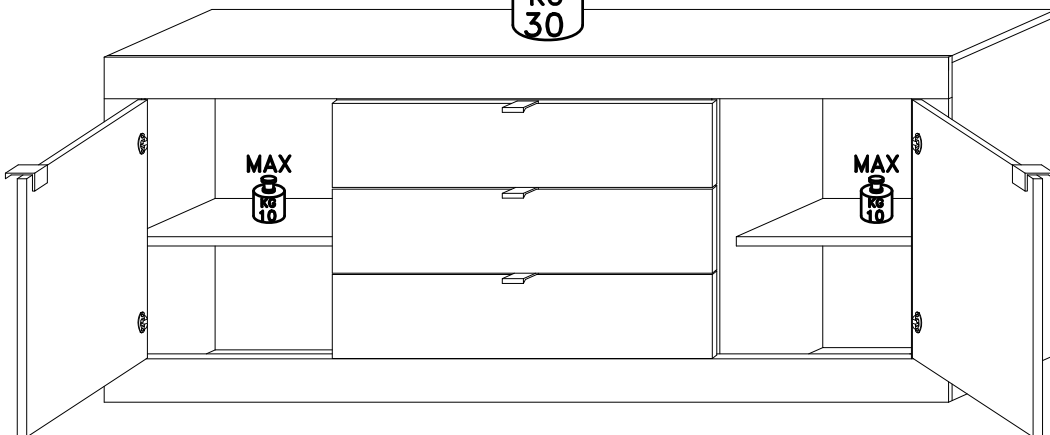
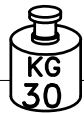

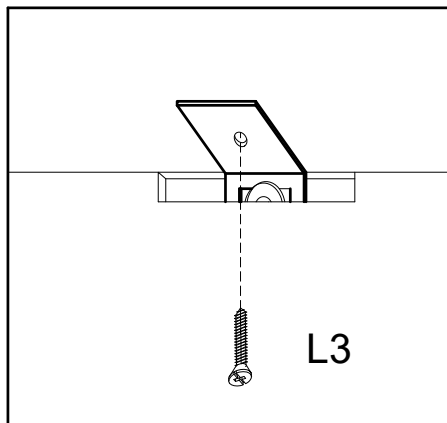
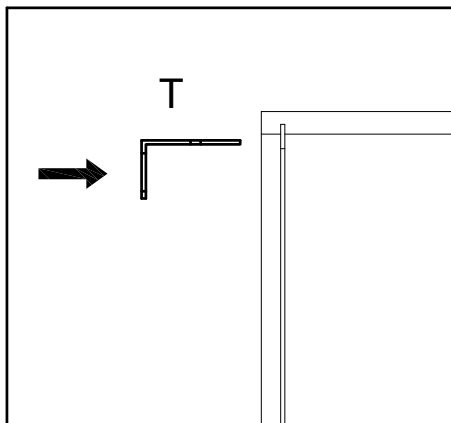

## OPTIONAL

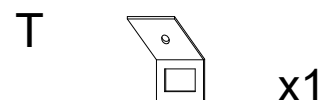

Gentile Cliente

Il montaggio dei pensili deve essere effettuato da personale competente.

I tasselli di fissaggio non sono compresi nella ferramenta.

Scegliere il tipo di tassello per il fissaggio più adatto alla tipologia di muro.

Assicurarsi l'idoneità della parete per un sostegno sicuro del pensile.

Dear Customer,

The assembling of the hanging elements must be done by a competent staff.

The wall plugs are not included in the hardware package.

Choose the wall plugs more suitable to the type of the wall.

Ensure the suitability of the wall for a secure support of the hanging element.

Sehr geehrter Kunde, die Montage der Hängeelemente muss von Fachpersonal ausgeführt werden!

Bitte verwenden Sie eigene Dübel, die der Beschaffenheit der Wand entsprechen.

Zu Ihrer eigenen Sicherheit legen wir dem Beschlagbeutel keine Dübel bei.

Cher client, les éléments muraux ne peuvent être installés que par du personnel qualifié !  
Veuillez utiliser vos propres ancrages adaptés à la nature du mur.

Pour votre sécurité, nous n'incluons pas de chevilles dans le matériel.

Estimado cliente, el montaje de los muebles colgados en la pared debe ser realizado por personal competente.

Los tacos de fijación no están incluidos en la bolsa de herrajes.

Elija el tipo de anclaje de fijación que mejor se adapte al tipo de pared.

Asegúrese de que la pared sea adecuada para un soporte seguro del mueble colgado en la pared.

