

-07P2

Montageanweisung / Installation instructions / Instruction de montage / Istruzioni di montaggio
montagehandleiding / Instrukcja montażu / Montaj talimatlar / Osszeszerelési útmutató / Návod k montáži /
Návod na montáž / Instrucțiune de montaj / Инструкция по монтажу / Montaj talimatina / Monteringsanvisningar
Upute za montažu / Instrucciones de Montaje / Navodila za montažo

DAMA-MIRO PRISMA

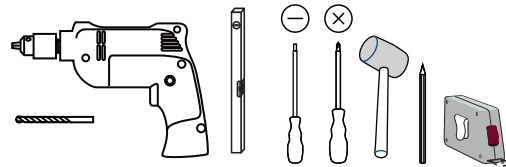
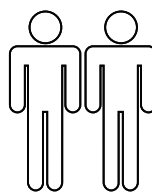
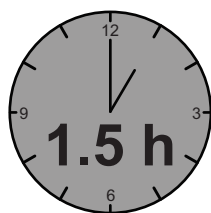

LC S.p.A
Via del Piano s.n
61030 Isola del Piano
(PU) Italia
<http://www.lcmobili.com>

Pt – leia atentamente as instruções de montagem,
uma vez
que não assumimos qualquer responsabilidade
por defeitos
resultantes de uma montagem incorrecta.

Pl – prosze uwaznie zapoznac sie z instrukcja montazu,
Poniewaz nie ponosimy odpowiedzialnosc za niewlasciwy montaz.

HU – Kérjük, olvassa el figyelmesen
ezt az összeszerelési útmutatót,
mert a helytelen összeszerelésből
a dódó hibákért nem vállalunk felelősséget!

SK – Prosime, dobre prečítajte si tento návod na montáž,
pretože nepreberáme žiadne ručenie za chyby,
ktoré vzniknú na základe chybnej montáže!

RO – Vă rugăm să cititi cu atenție aceste instrucțiuni
de montaj deoarece nu preluăm garanția pentru defecte
ce apar datorită unui montaj incorect!

RUS – Пожалуйста, внимательно ознакомьтесь ù
с данной инструкцией по монтажу, поскольку мы не
несем ответственности за ошибки, причиной которых
является неправильный монтаж.

TU – İlkonce kullanma klavuzunu iyi okuyun,
yalnis montaj yapasaniz bunun sorumlusu biz degiliz.

ES – Se ruega leer con atención las instrucciones
de montaje debido a que declinamos cualquier
responsabilidad
por defectos derivados de un montaje erróneo.

RS – Pažljivo pročítajte priložena uputstva za montažu
jer ne možemo prihvatiti reklamacije kao osnovane za
greške nastale kao rezultat nepravilne montaže

D – bitte lesen sie diese montageanleitung gut durch,
Da wir für fehler, die durch falsche montage entstehen,
Keine haftung übernehmen!

Gb – please read these installation instructions
Through carefully as we cannot accept any liability
For faults occurring as a result of incorrect installation!

Cz – přečtete si prosim pozorně tento návod k montáži,
Aby jste předešli chybám vzniklých špatnou montáží,
Za které neručíme!

F – veuillez lire attentivement cette notice de montage,
Car nous déclinons toute responsabilité en cas d'erreurs
Découlant d'un montage erroné !

I – prego leggere attentamente le istruzioni per il montaggio,
Poiché decliniamo qualsiasi responsabilità
Per difetti derivanti da montaggio errato.

S - läs monteringsanvisningarna noggrant.
Vi avsäger oss allt ansvar för defekter som
Uppstår p.g.a. Felaktig montering.

Hr – pažljivo pročítajte upute za montažu,
Jer otklanjamo svaku odgovornost za pogreške
Nastale uslijed pogrešne montaže.

Slo – prosimo, da pozorno preberete navodila za montažo,
Saj zavračamo vsakršno odgovornost za napake,
Ki bi nastale zaradi napačne montaže.

Nl – leest u alstublieft deze montagehandleiding goed door,
Voor fouten door verkeerde montage zijn wij niet verantwoordelijk.



PARTI DI RICAMBIO - SPARE PARTS

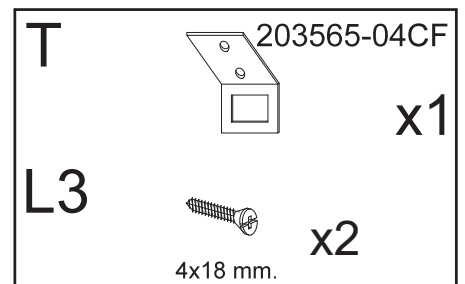
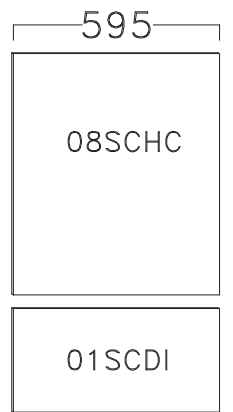
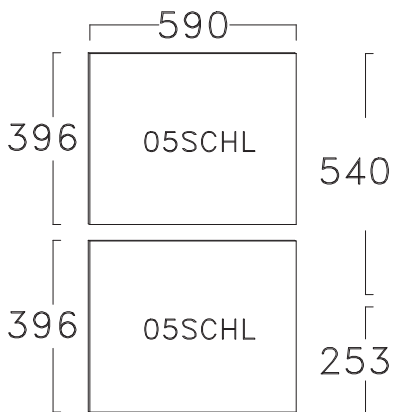
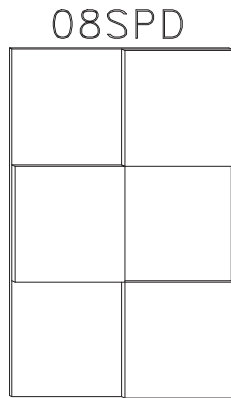
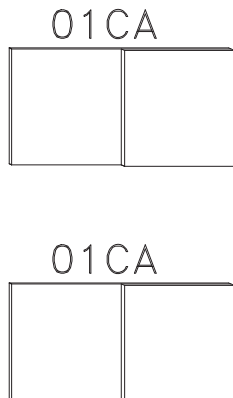
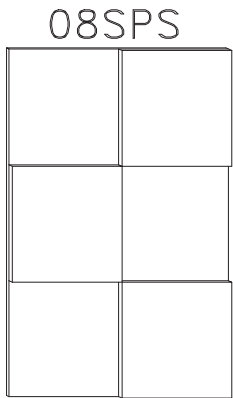
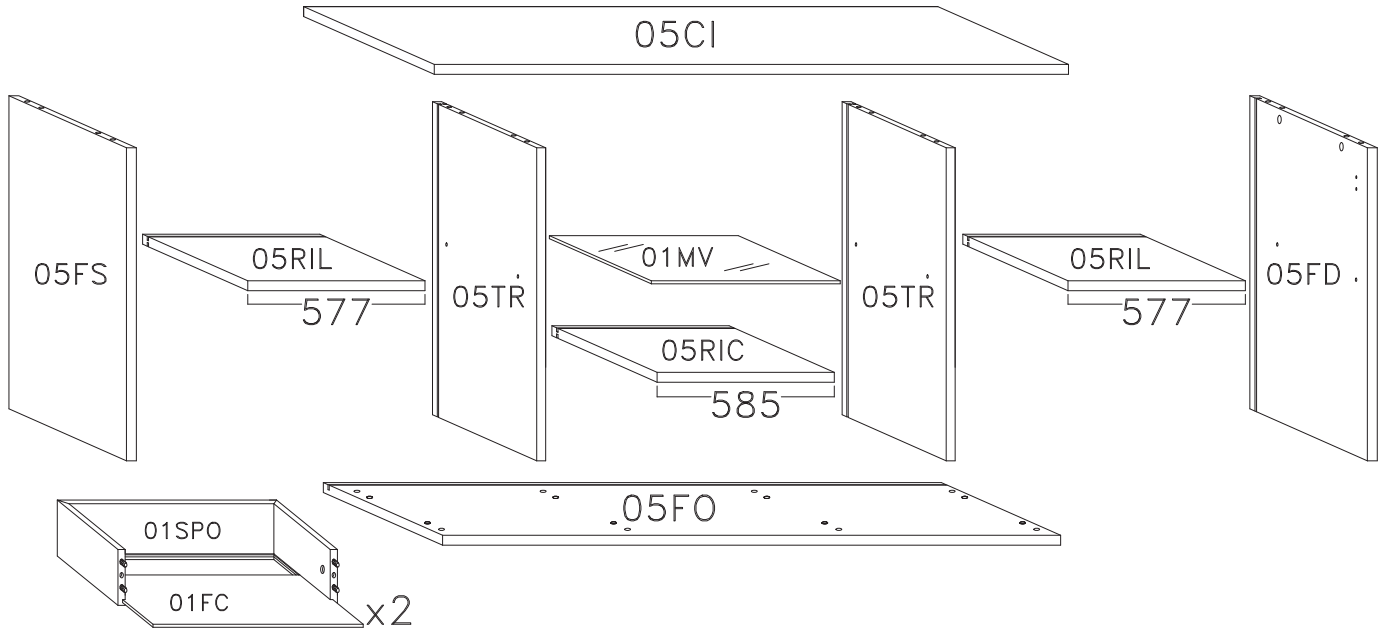
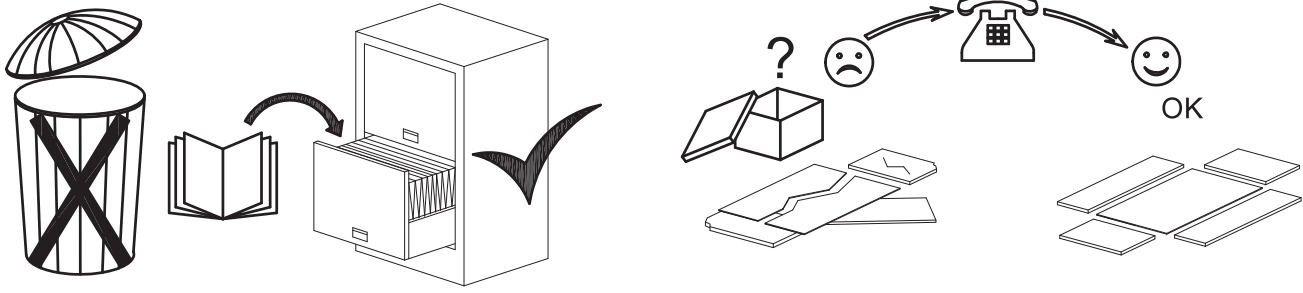

ONDERDELEN LYST-SERVICEKARTE-FORMULAIRE DEMANDES SAV-SPAREPARTS LIST-SCHEDA DI SERVIZIO

BESLAG-BESCHLAEGE - QUINCALLERIE - HARDWARE - FERRAMENTA

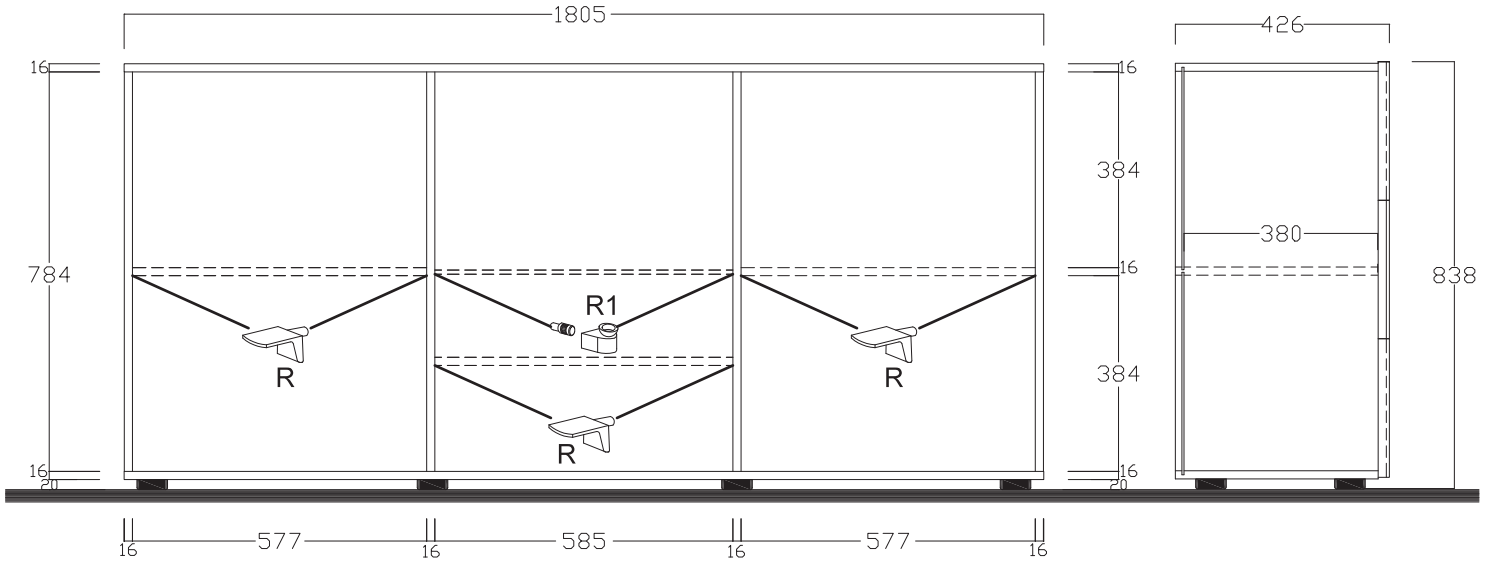

209008-07CF

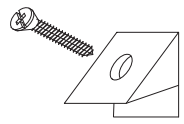
F  **x40**

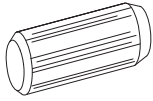
B  **x16**
8x30 mm.

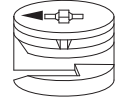
C  **x8**
Ø15 mm.

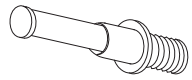
D  **x8**

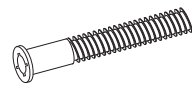
E  **x8**
7x60 mm.

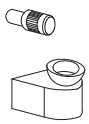
R1  **x4**

M11  **x8**
6x11 mm.

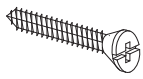
L4530  **x6**
4.5x30 mm.

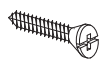
L3516  **x8**
3x16 mm.

P  **x6**

R  **x12**

T20  **x8**
Ø20 mm.

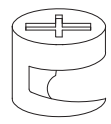
C1  **x8**
531010-01SCFS
Ø12 mm.

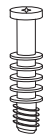
D1  **x8**

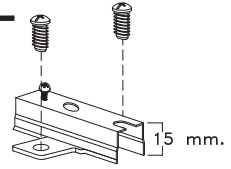
H2E  **x4**
209008-08CC
15 mm.

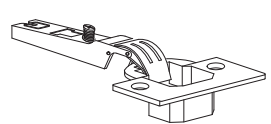
C0  **x4**

L15  **x8**
4x15 mm.

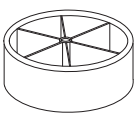
F21  **x6**
205124-06PIE
Ø 60 mm
h 20 mm

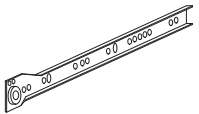
CL  **x2**
209493-07GUI

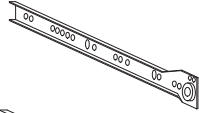
CR  **x2**

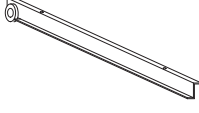
DR  **x2**

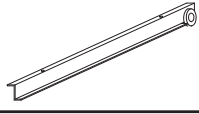
DL  **x2**

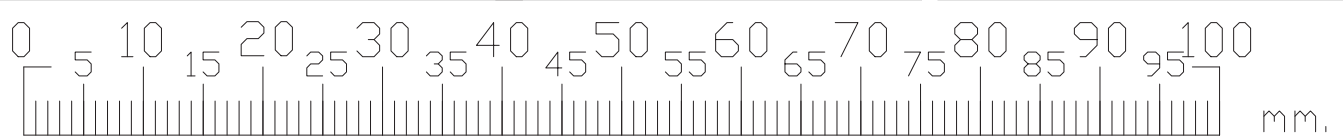

1

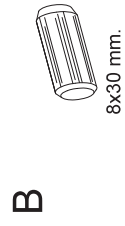
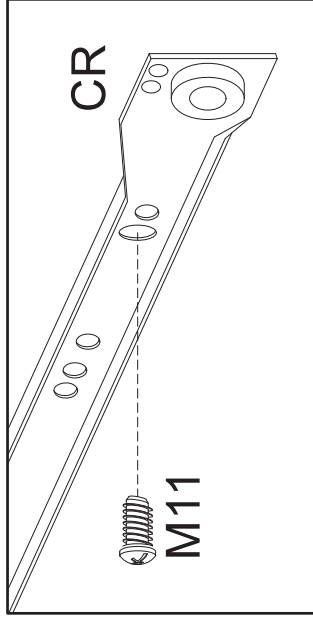
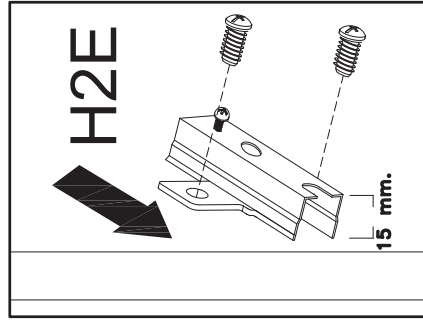

x12

x8

R

R1



x12

x4



CL

CR

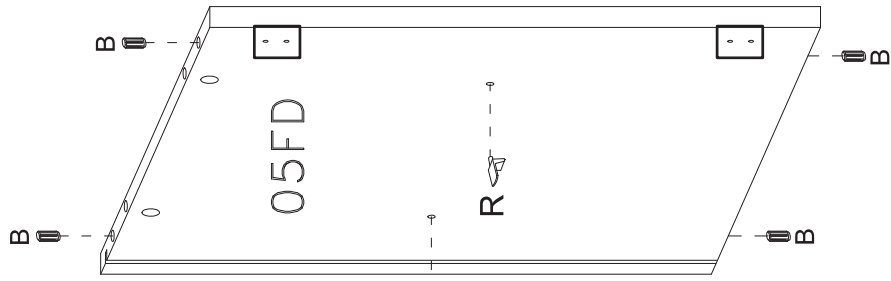
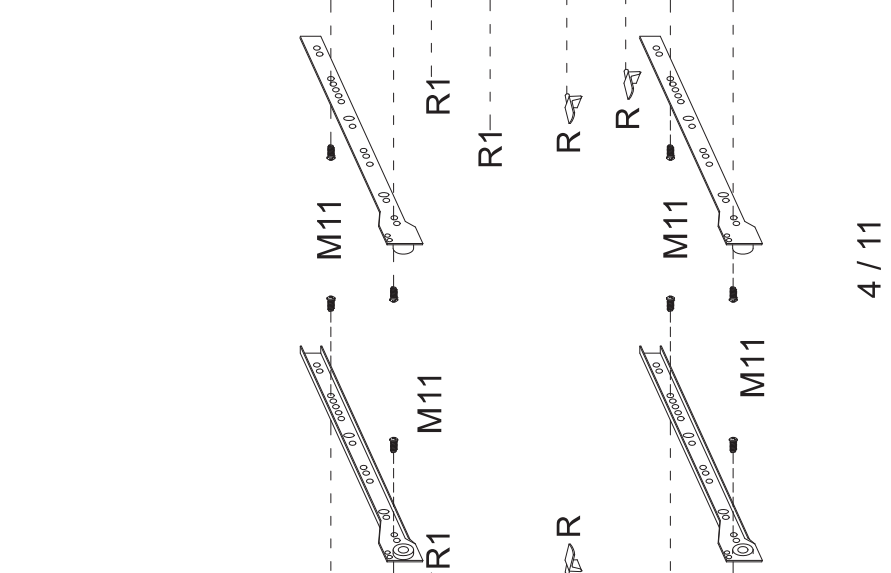
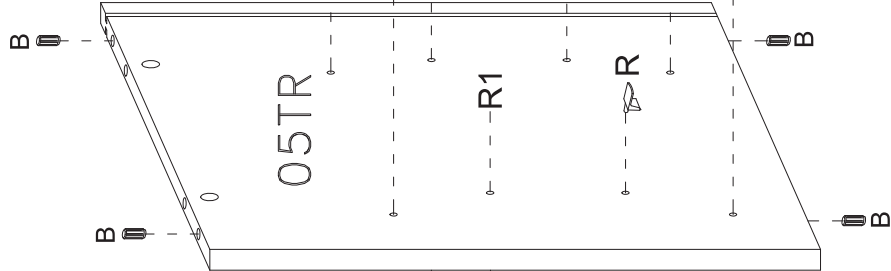
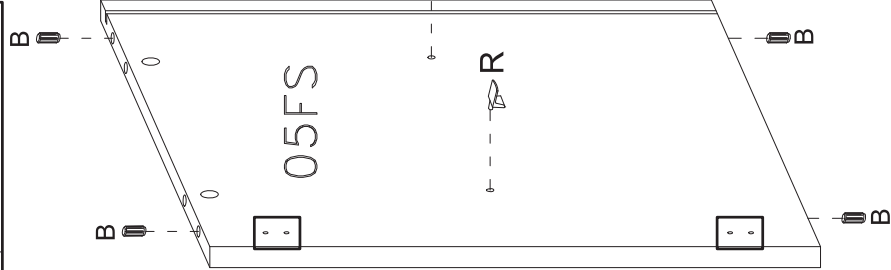
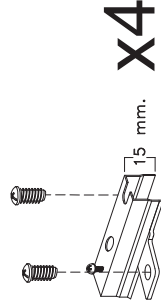
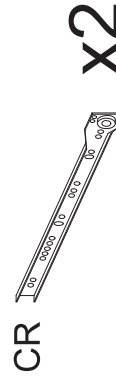
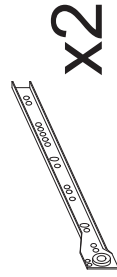
H2E



2

- E  7x60 mm. x8
- L4530  4.5x30 mm. x6
- F21  Ø 60 mm h 20 mm x6

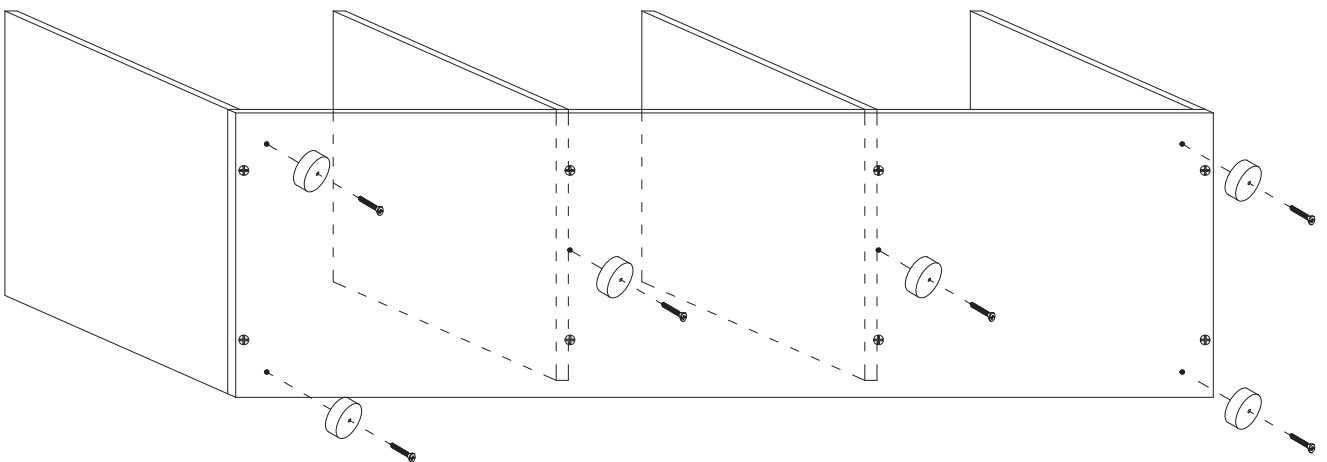
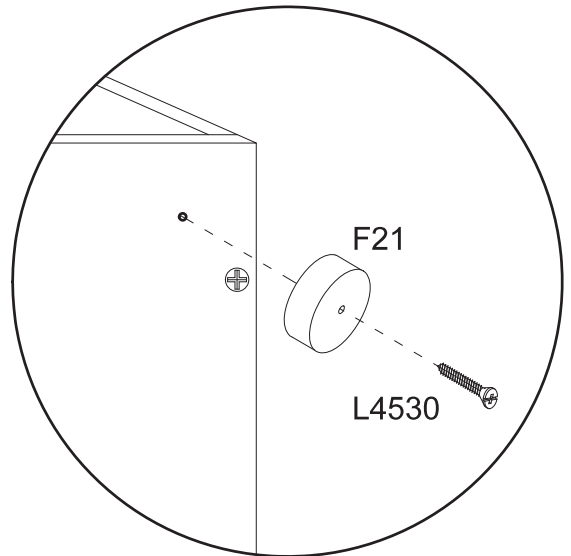
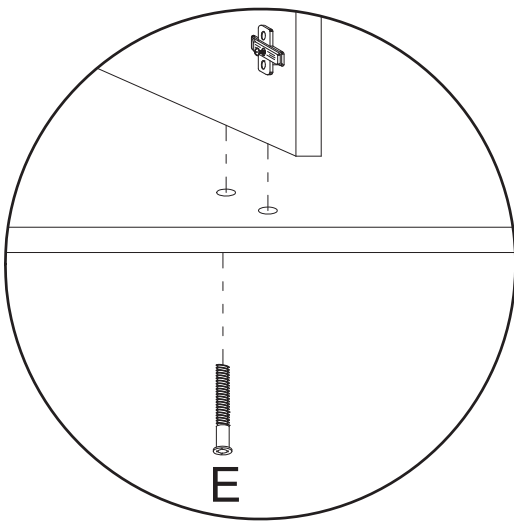
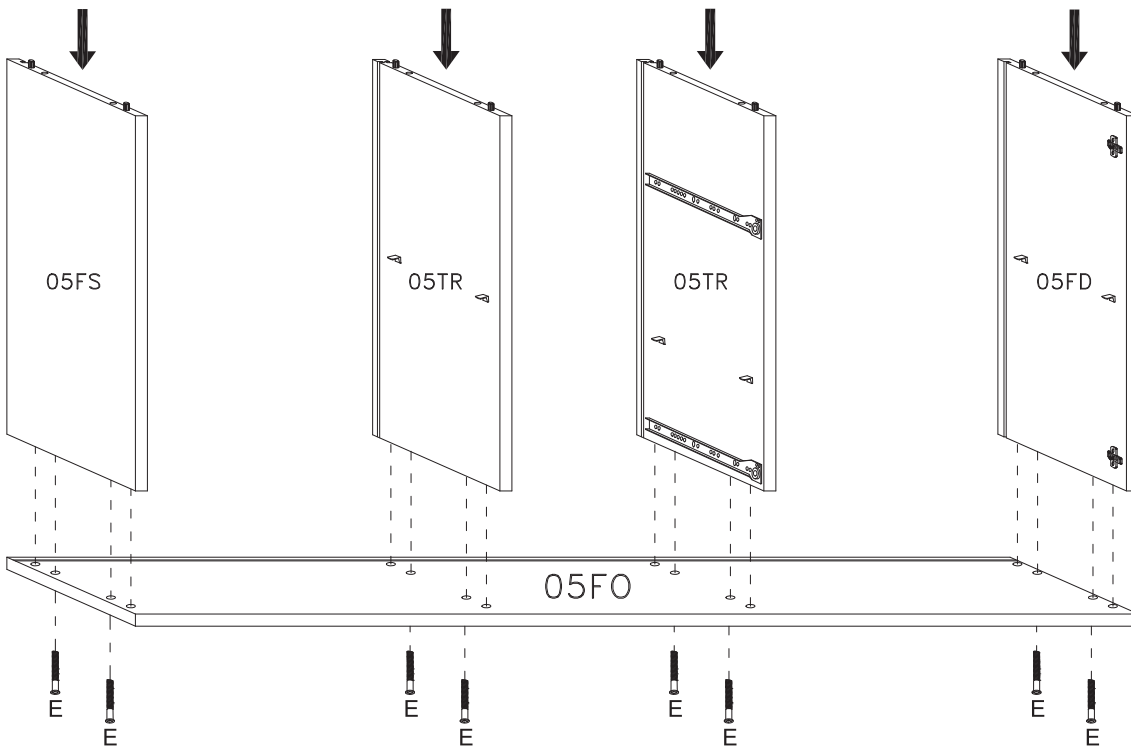

3

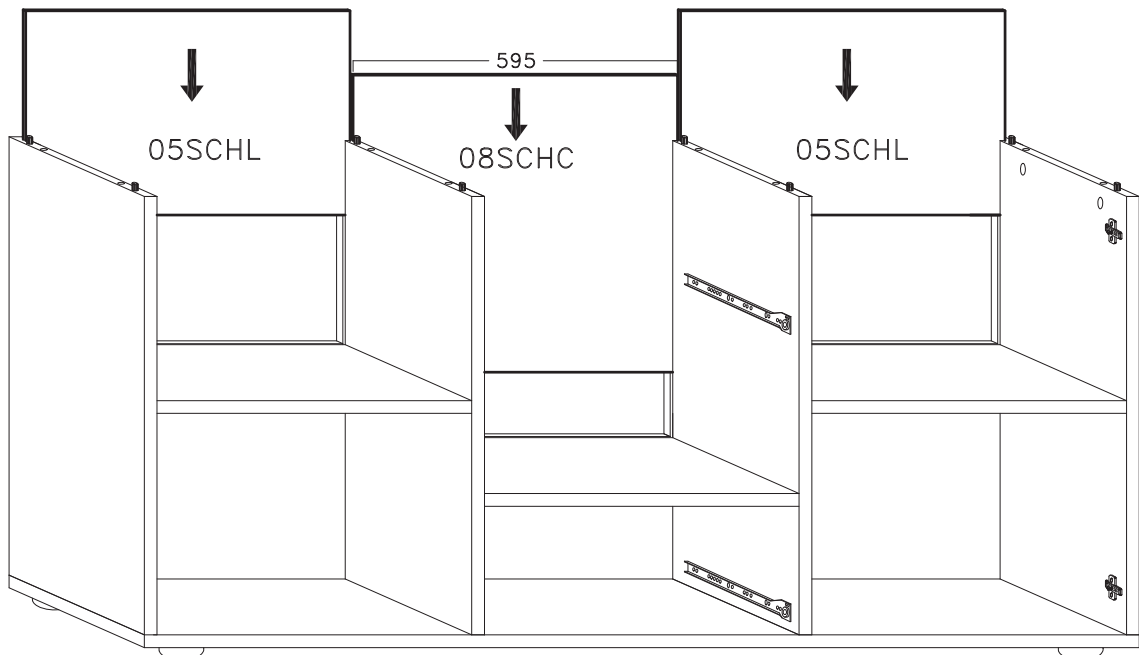
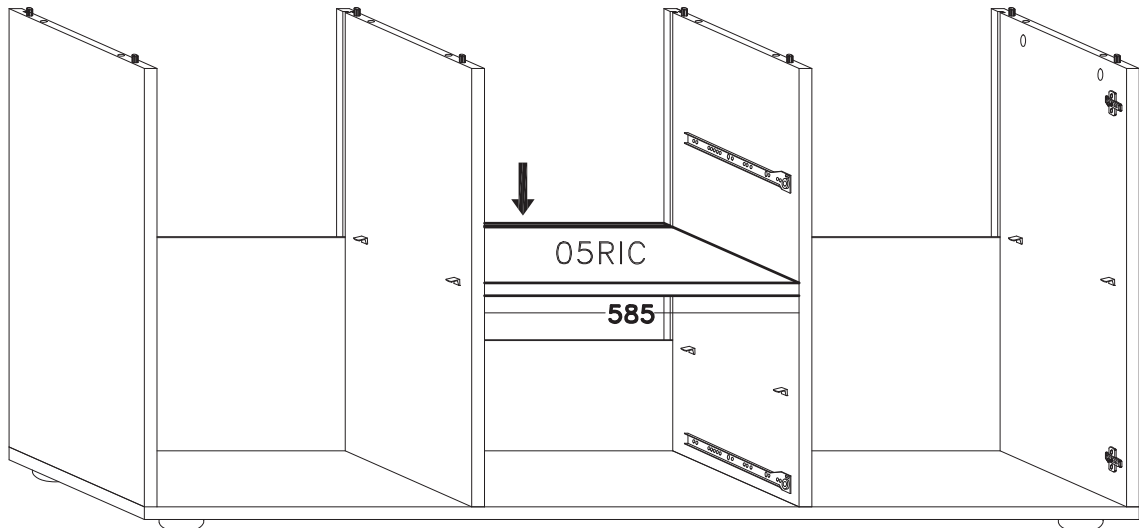
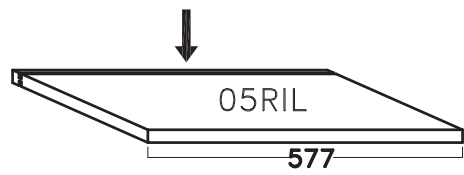
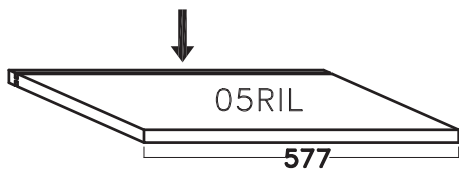
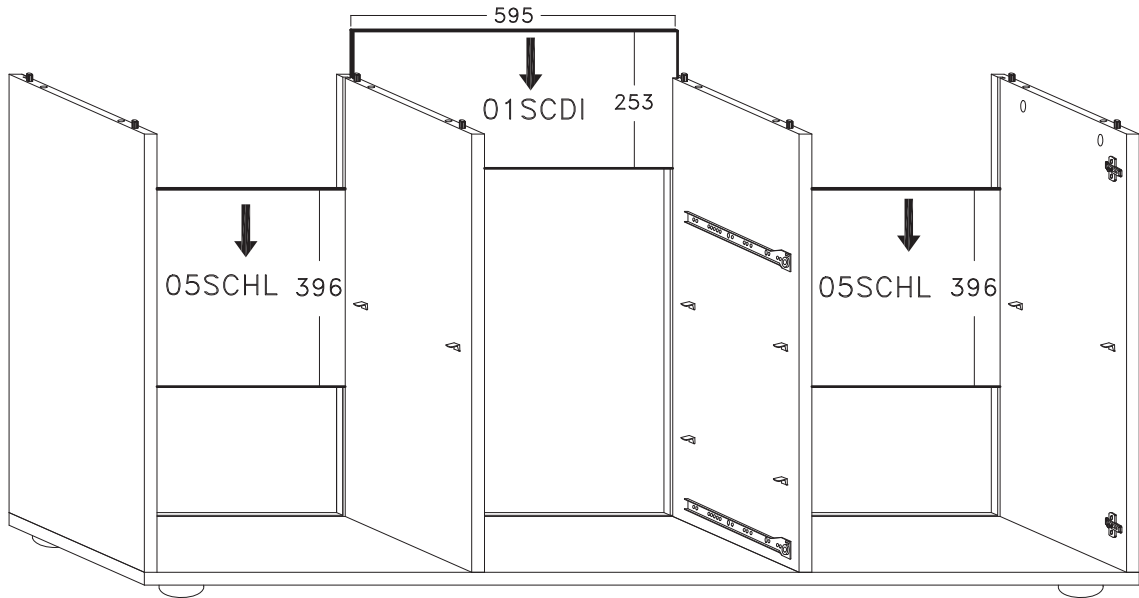

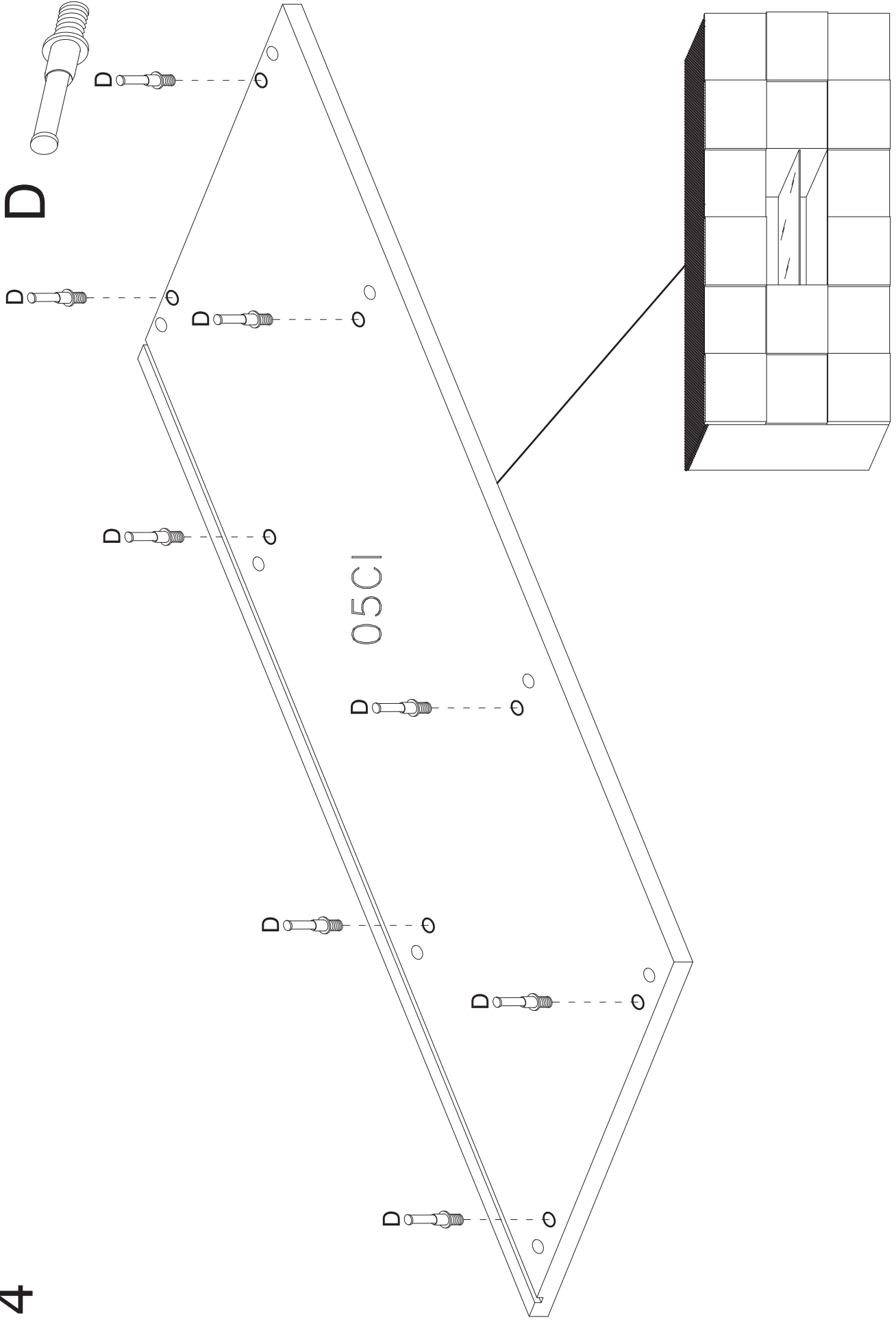

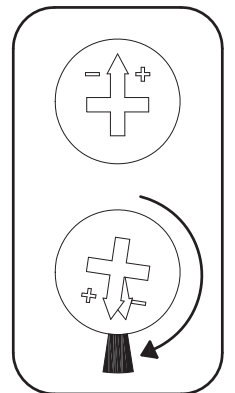
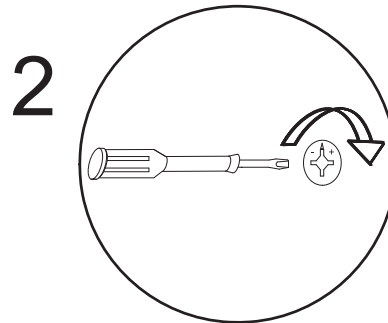
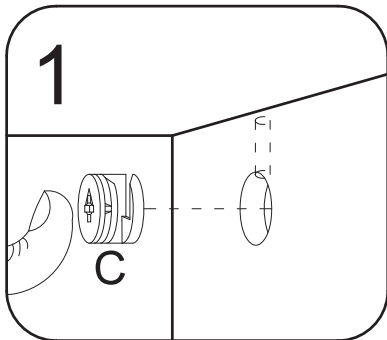
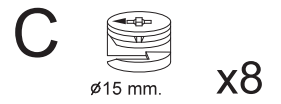
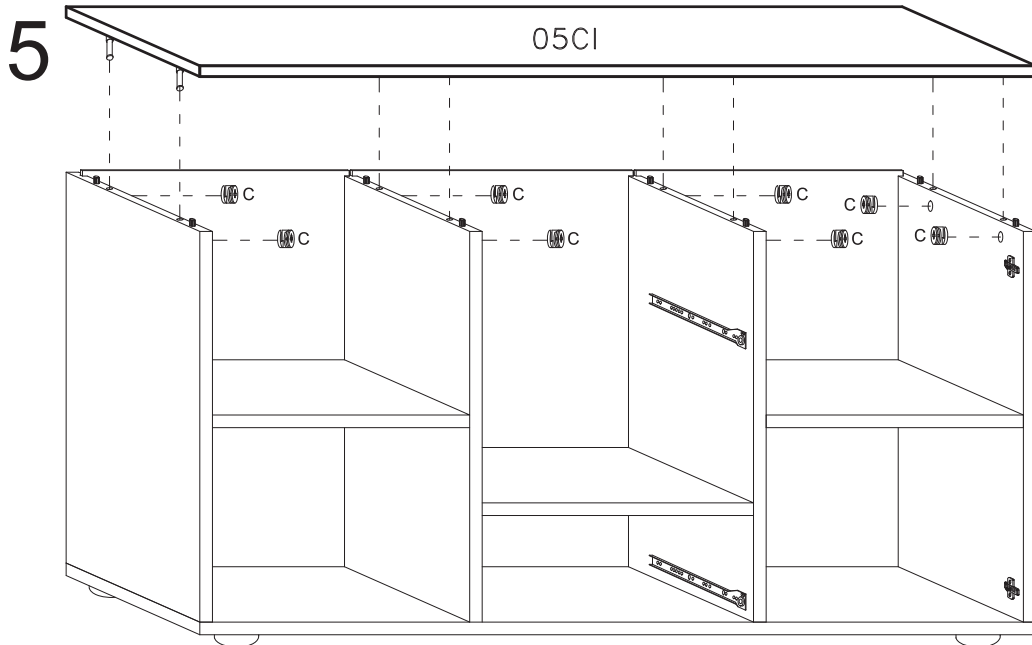



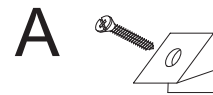
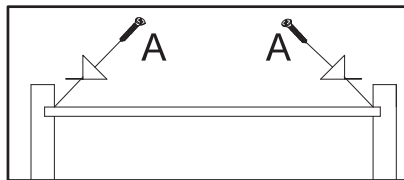

6

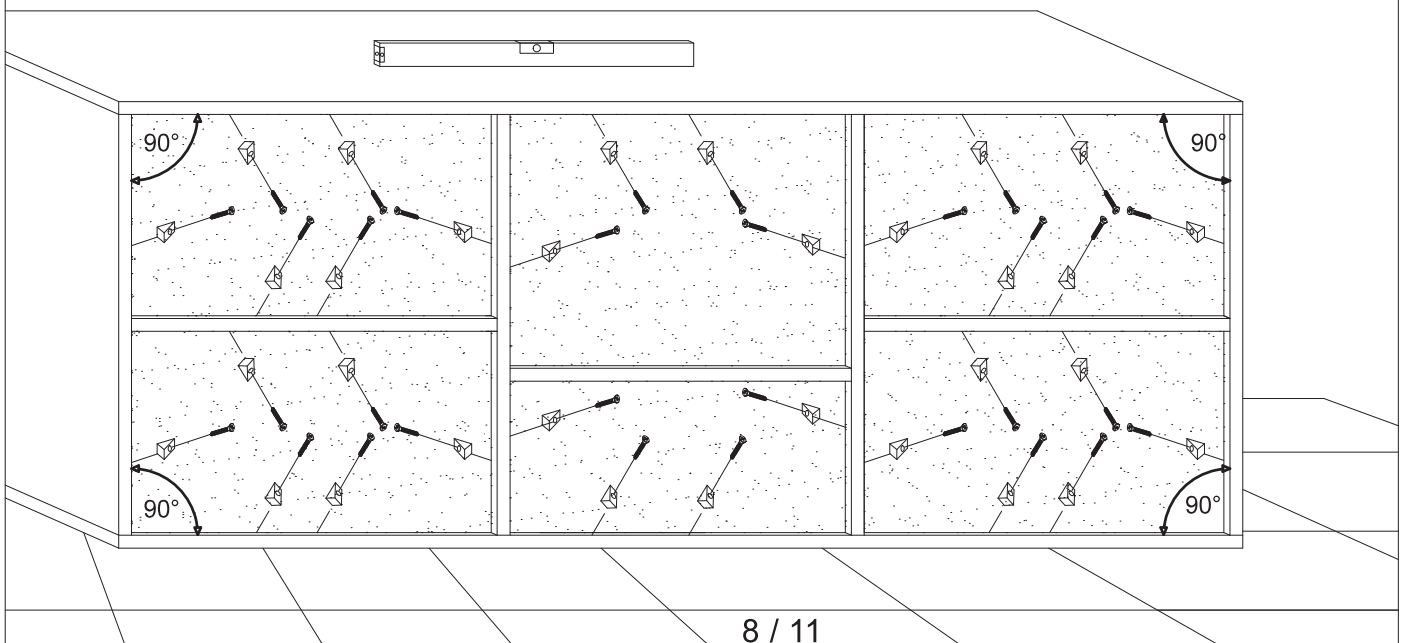

x32

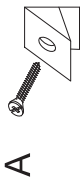
RETRO-BACK



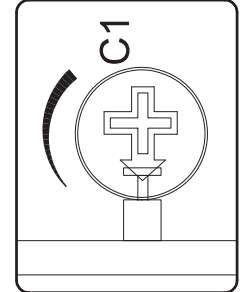
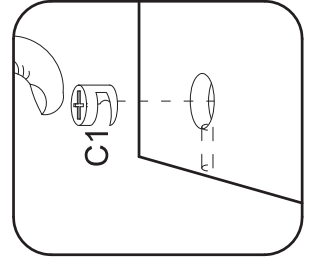
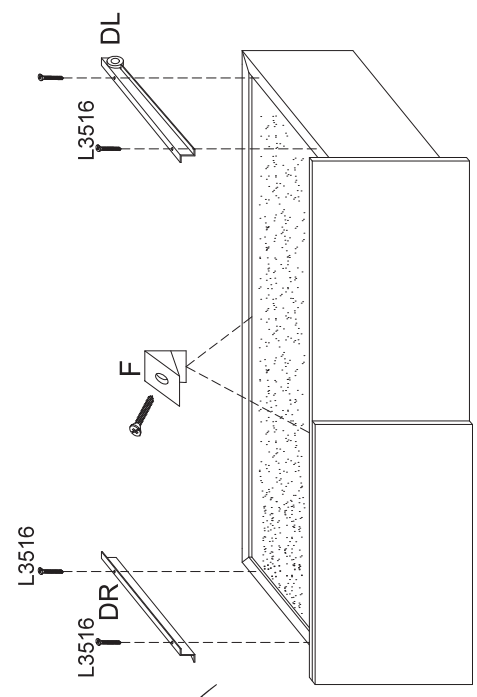
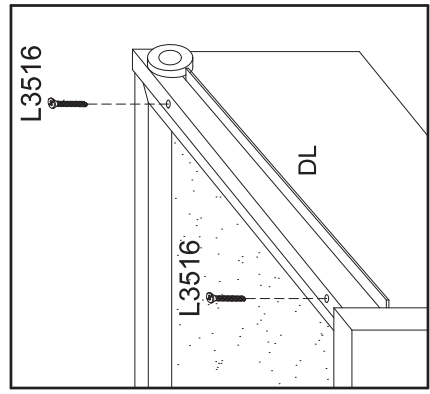
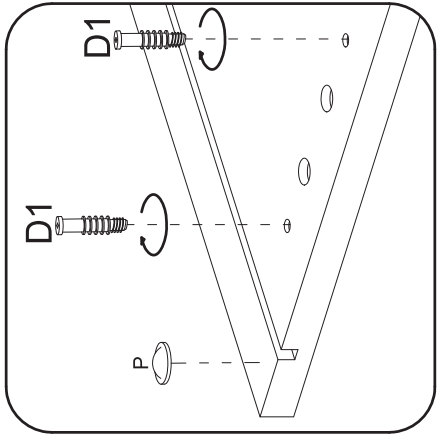
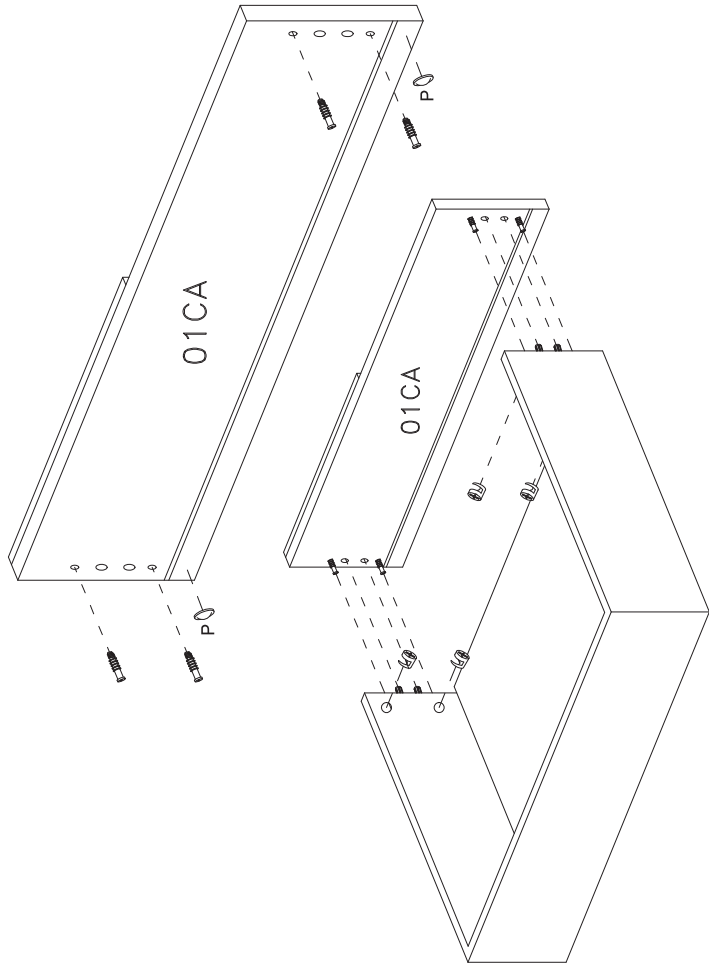
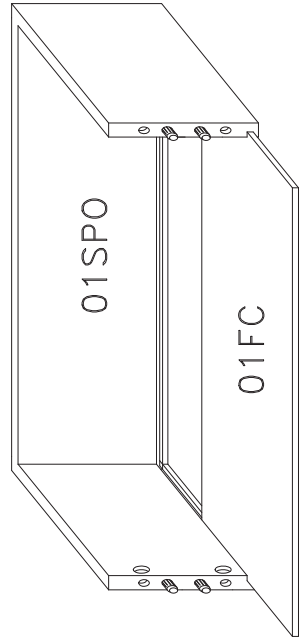

- A  D1
- P  L3516
- C1  3x16 mm.
- DR  X2
- DL  X2
- X4
- X4
- X8

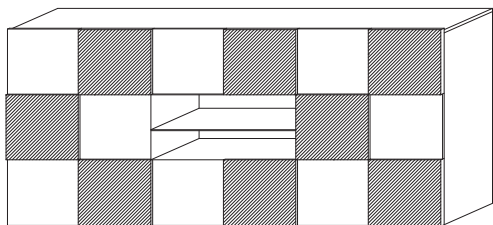

8

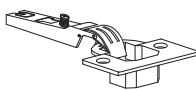

- C0  x4
- L15  x8
- P  4x15 mm. x2

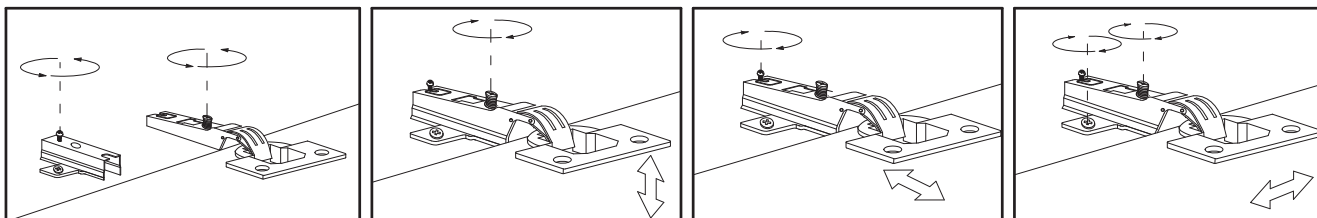
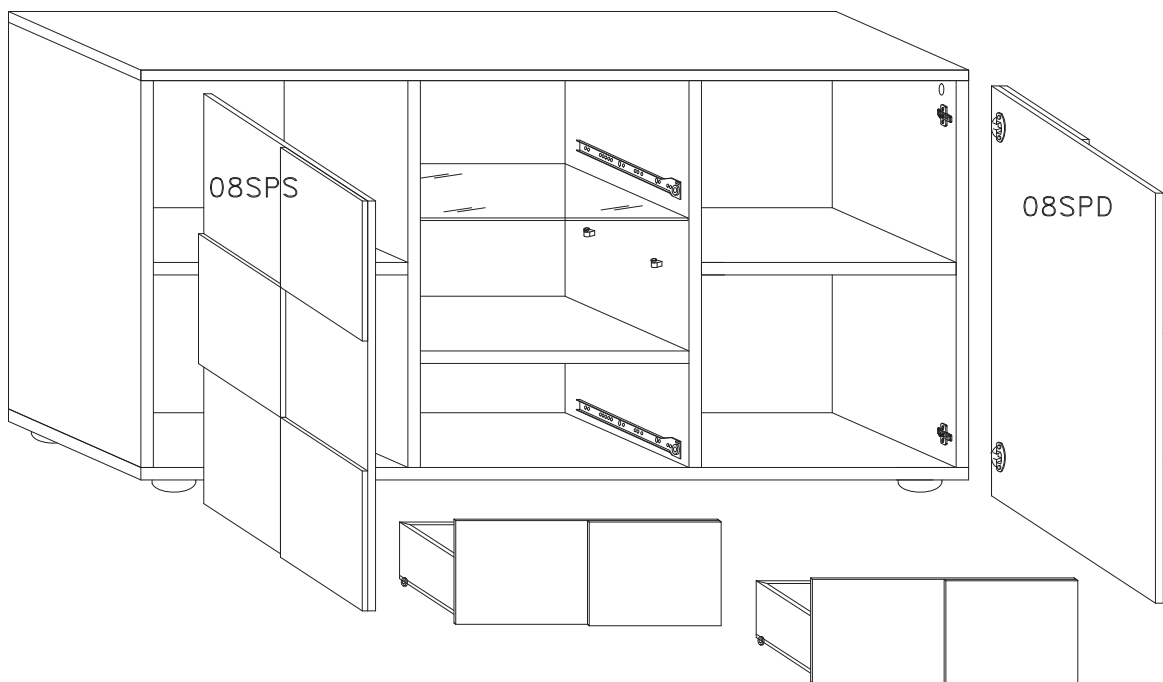
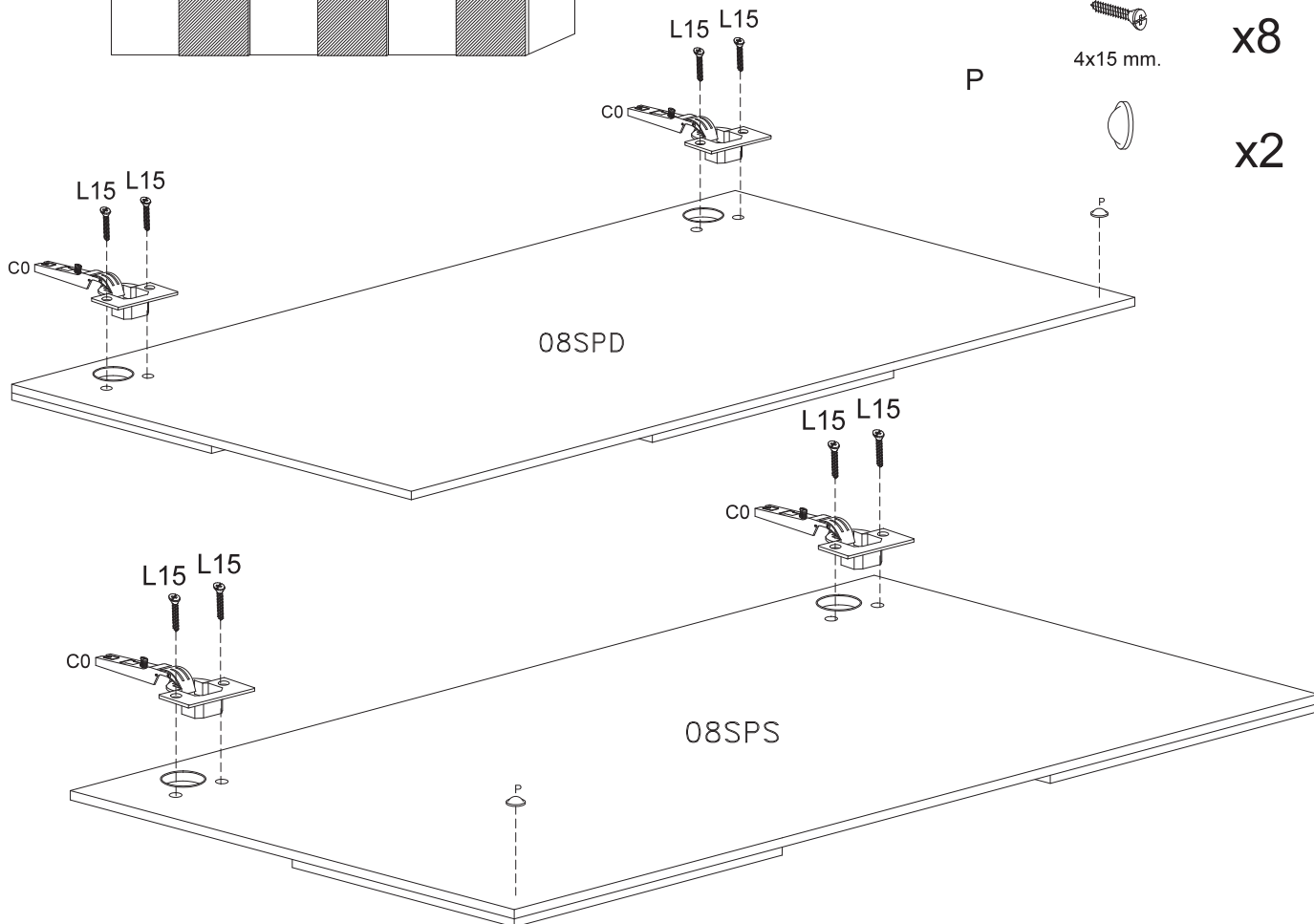

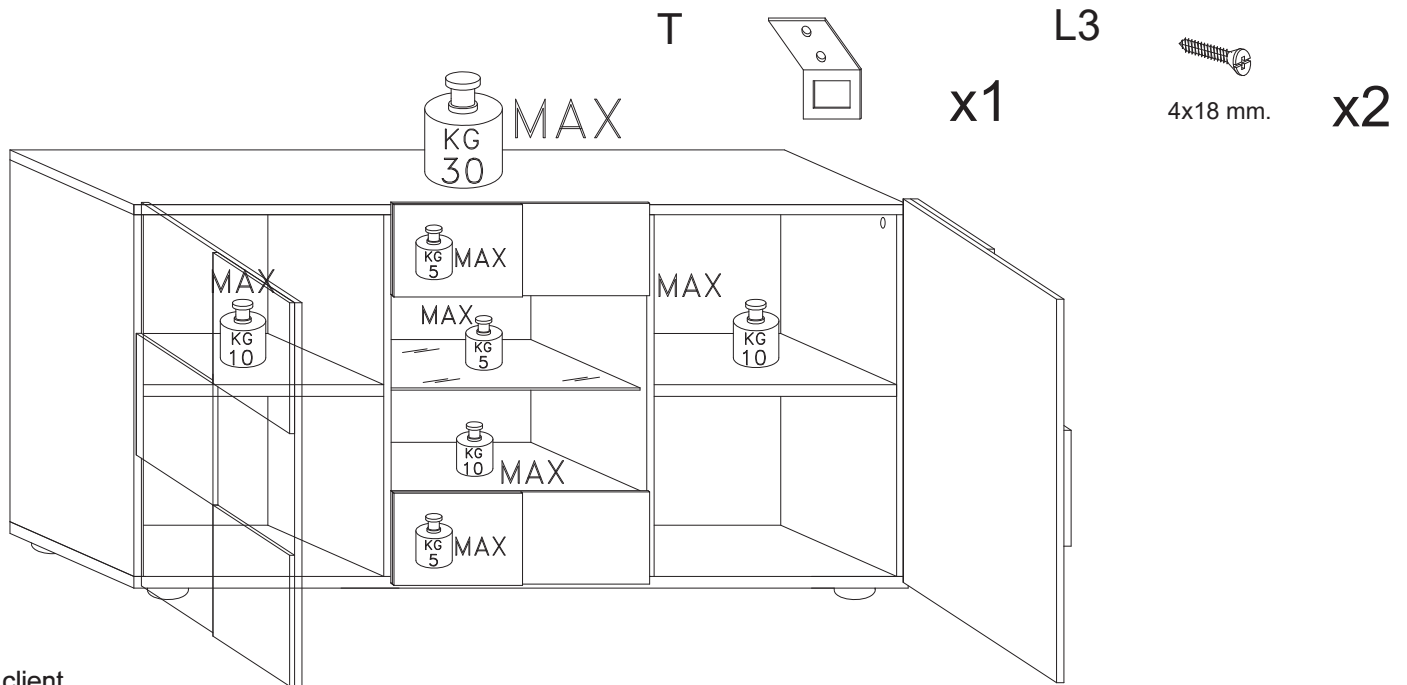

Cher client,
l'installation des meubles suspendus doit être effectuée par un personnel compétent. Les fischers ne sont pas inclus dans la quincaillerie.

Choisir les types des fischers pour le fixage apte au mur.
S'assurer de l'adéquation du mur pour support sûr du meuble

Dear Customer

The assembling of the hanging elements must be done by a competent staff.

The fishers are not included in the hardware package.

Choose the fisher more suitable to the type of the wall.

Ensure the suitability of the wall for a secure support of the hanging element.

Sehr geehrter Kunde, die Montage der Haengeelemente muss von Fachpersonal ausgefuehrt werden! Bitte verwenden Sie eigene, der Beschaffenheit der Wand entsprechende Duebel. Zu Ihrer eigenen Sicherheit legen wir dem Beschlagbeutel keine Fischerduebel bei.

Gentile Cliente

Il montaggio dei pensili deve essere effettuato da personale competente.

I tasselli di fissaggio non sono compresi nella ferramenta.

Scegliere il tipo di tassello per il fissaggio più adatto alla tipologia di muro.

Assicurarsi l'idoneità della parete per un sostegno sicuro del pensile.

Poštovani kupče:

Montažu visećih elemenata mora obaviti stručno osoblje. Zavrtnji i ankeri za zid nisu uključeni u paket okova. Izaberite šrafove koji odgovaraju vrsti zida. ūbezbedite da zid predstavlja siguran oslonac visećeg elementa

