

20__10-08P2

Montageanweisung / Installation instructions / Instruction de montage / Istruzioni di montaggio
montagehandleiding / Instrukcja montażu / Montaj talimatlar / Összeszerelési útmutató / Nàvod k montáži /
Nàvod na montaz / Instrucțiune de montaj / Инструкция по монтажу / Montaj talimatina / Monteringsanvisningar
Upute za montažu / Instrucciones de Montaje / Navodila za montažo

FANTASY

INFINITY 2.0

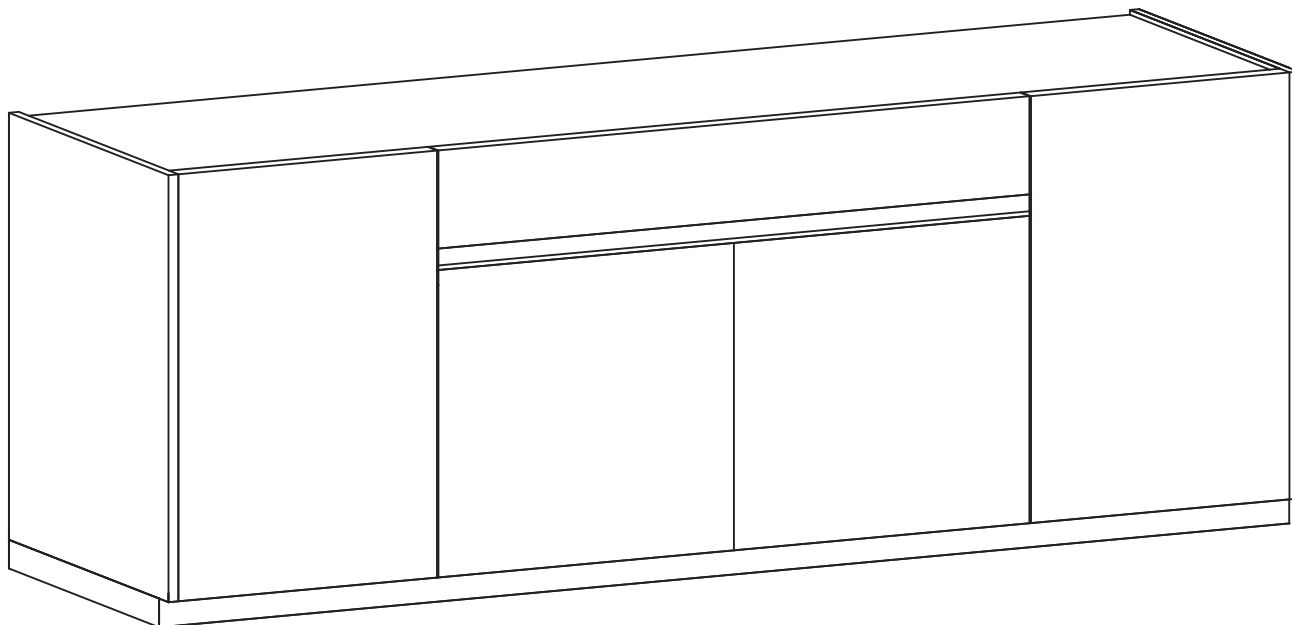
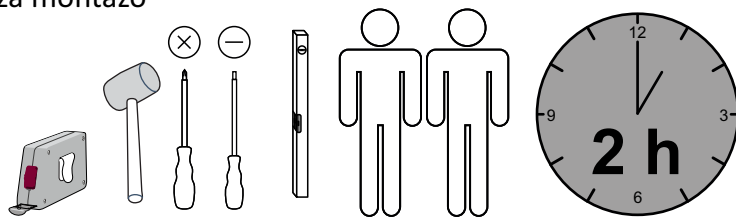

LC S.p.A
Via del Piano s.n
61030 Isola del Piano (PU)
Italia
<http://www.lcmobili.com/>

D – bitte lesen sie diese montageanleitung gut durch,
Da wir für fehler, die durch falsche montage entstehen,
Keine haftung übernehmen!

Gb – please read these installation instructions
Through carefully as we cannot accept any liability
For faults occurring as a result of incorrect installation!

Cz – přečtěte si prosím pozorně tento návod k montáži,
Aby jste předešli chybám vzniklých špatnou montáží,
Za které neručíme!

F – veuillez lire attentivement cette notice de montage,
Car nous déclinons toute responsabilité en cas d'erreurs
Découlant d'un montage erroné !

I – prego leggere attentamente le istruzioni per il montaggio,
Poiché decliniamo qualsiasi responsabilità
Per difetti derivanti da montaggio errato.

S - läs monteringsanvisningarna noggrant.
Vi avsåger oss allt ansvar för defekter som
Uppstår p.g.a. Felaktig montering.

Hr – pažljivo pročitajte upute za montažu,
Jer otklanjamo svaku odgovornost za pogreške
Nastale uslijed pogrešne montaže.

Slo – prosimo, da pozorno preberete navodila za montažo,
Saj zavračamo vsakršno odgovornost za napake,
Ki bi nastale zaradi napačne montaže.

NI – leest u alstublieft deze montagehandleiding goed door,
Voor fouten door verkeerde montage zijn wij niet verantwoordelijk.

Pl – prosze uwaznie zapoznac sie z instrukcja montazu,
Poniewaz nie ponosimy odpowiedzialnosci za niewlasciwy montaz.

HU – Kérjük, olvassa el figyelmesen
ezt az összeszerelési útmutatót,
mert a helytelen összeszerelésből
a dódó hibákért nem vállalunk felelősséget!

SK – Prosíme, dobre prečítajte si tento návod na montáž,
pretože nepreberáme žiadne ručenie za chyby,
ktoré vzniknú na základe chybnej montáže!









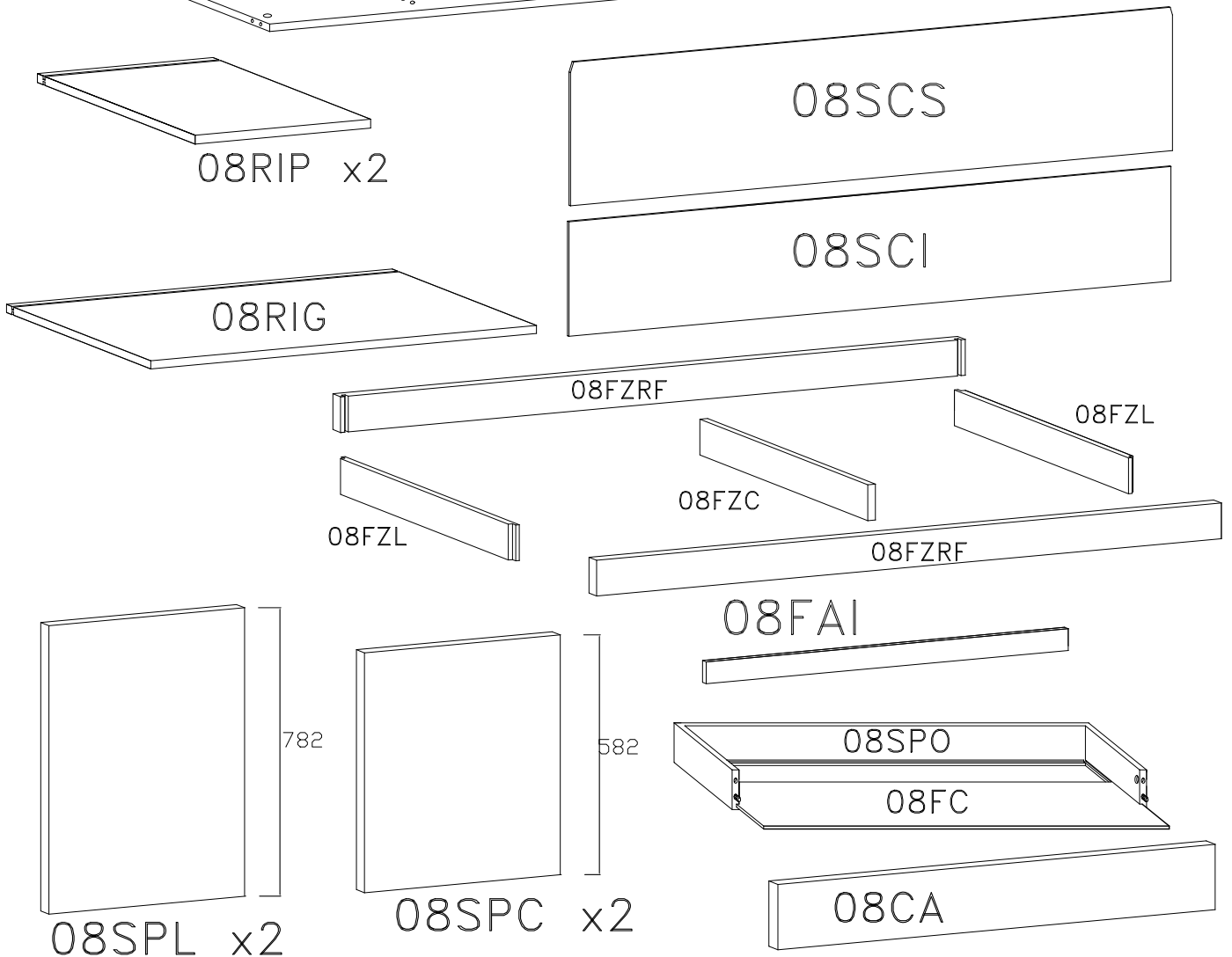
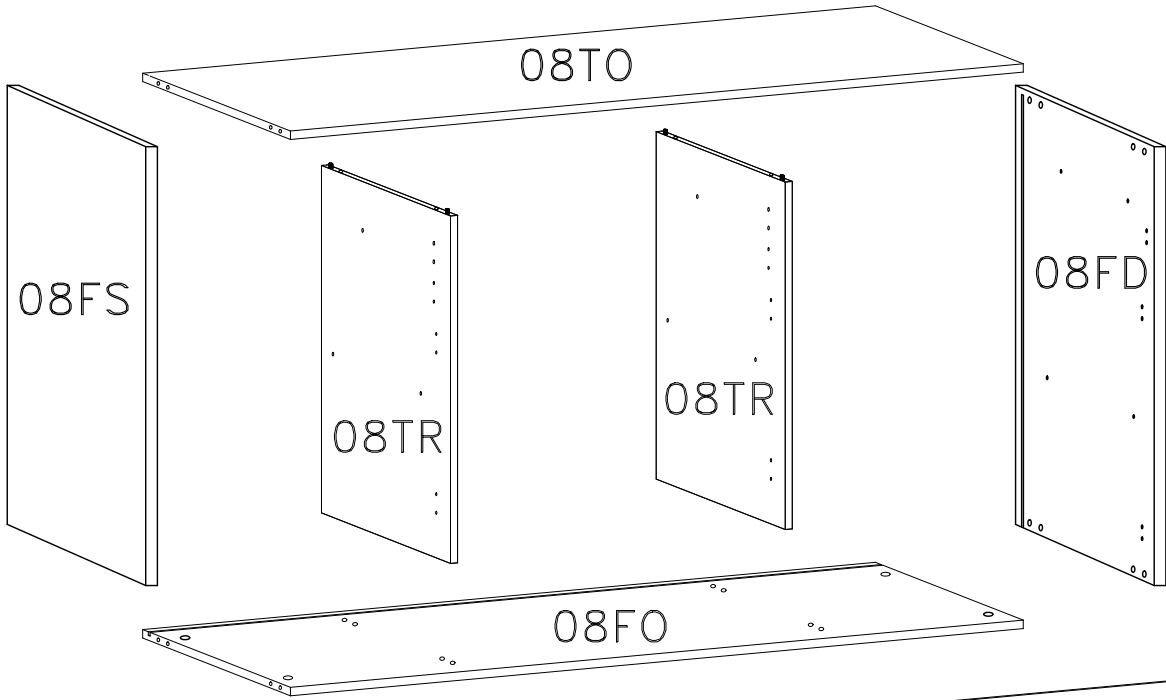
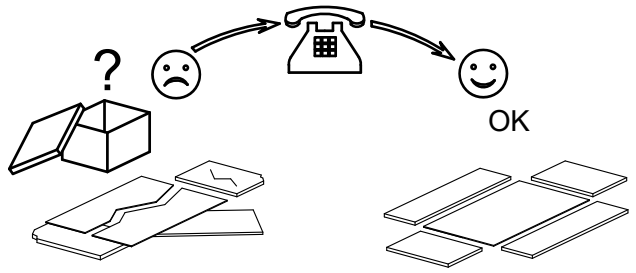
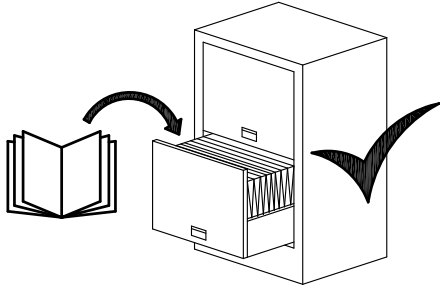
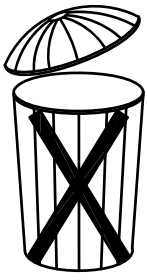

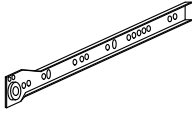
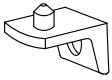
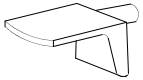
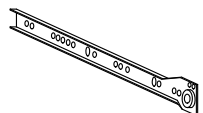
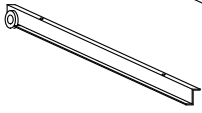

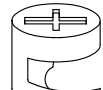
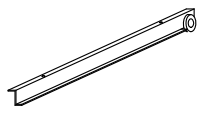
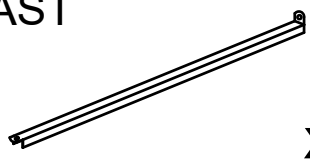
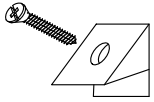
RO – Vă rugăm să cititi cu atenție aceste instrucțiuni
de montaj deoarece nu preluăm garanția pentru defecte
ce apar datorită unui montaj incorect!

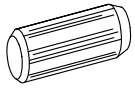
RUS – Пожалуйста, внимательно ознакомьтесь ù
с данной инструкцией по монтажу, поскольку мы не
несем ответственности за ошибки, причиной которых
является неправильный монтаж.

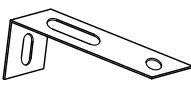
TU – İlkonce kullanma klavuzunu iyi okuyun,
yalnis montaj yapasaniz bunun sorumlusu biz degiliz.

ES – Se ruega leer con atención las instrucciones
de montaje deibido a que declinamos cualquier
responsabilidad
por defectos derivados de un montaje erróneo.

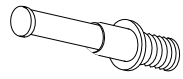
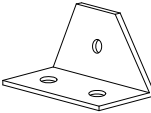

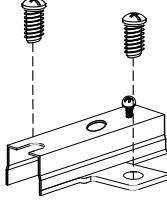
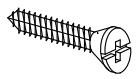
<p>M9</p>  <p>6x9 mm. x4</p>	<p>CL 209493-07GUI</p>  <p>x1</p>
<p>R2</p>  <p>x4</p> <p>R</p>  <p>x8</p>	<p>CR</p>  <p>x1</p> <p>DR</p>  <p>x1</p>
<p>E11</p>  <p>6x11 mm. x4</p> <p>C1</p>  <p>ø12 mm. x2</p>	<p>DL</p>  <p>x1</p> <p>N3AST</p>  <p>x1</p>
<p>F</p>  <p>x20</p> <p>D1</p>  <p>x2</p>	
<p>B</p>  <p>8x30 mm. x18</p> <p>L3516</p>  <p>3.5x16 mm. x6</p>	<p>PST</p>  <p>x1</p>
<p>C</p>  <p>ø15 x 12 mm x16</p> <p>F3</p>  <p>x8</p>	<p>P</p>  <p>x10</p>
<p>D</p>  <p>x16</p> <p>P7</p>  <p>x18</p>	<p>L418</p>  <p>4x18 mm. x56</p>
<p>C15</p>  <p>x8</p> <p>H4E</p>  <p>x8</p>	<p>L415</p>  <p>4x15 mm. x16</p>

1

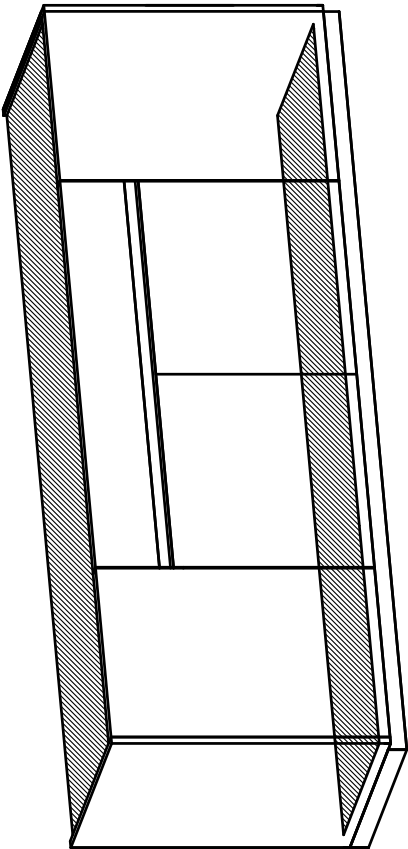

B

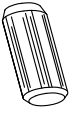

8x30 mm.

x8

D



x8

x2

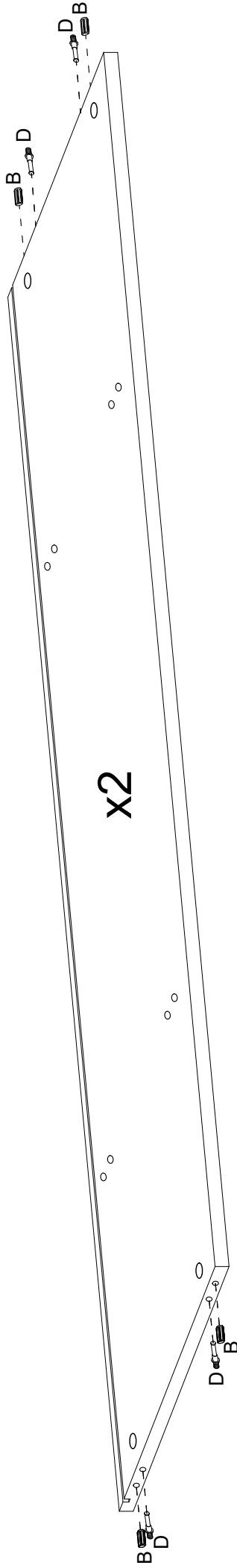

2

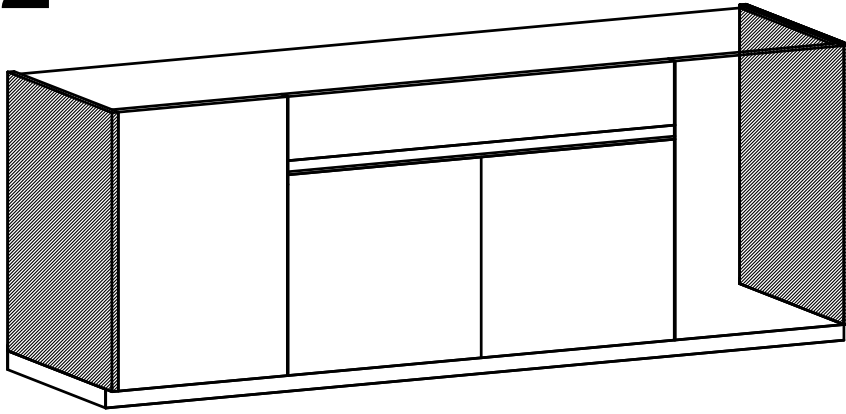

H4E

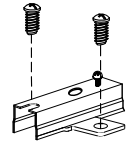

x4

R

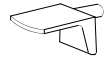



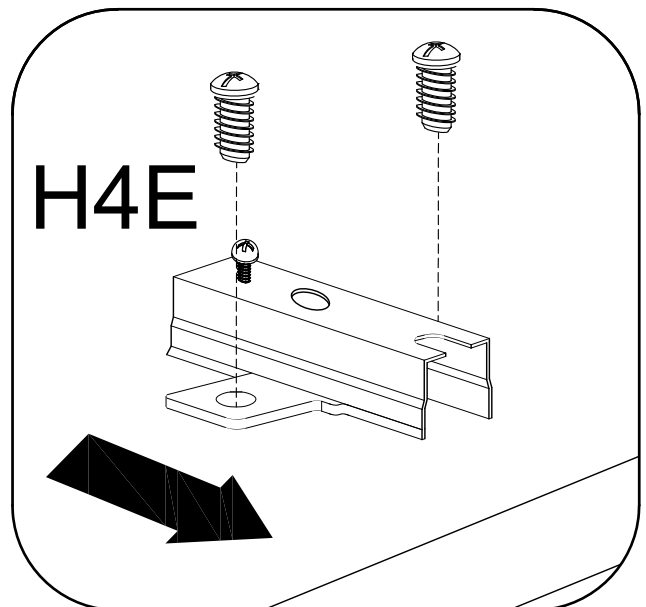
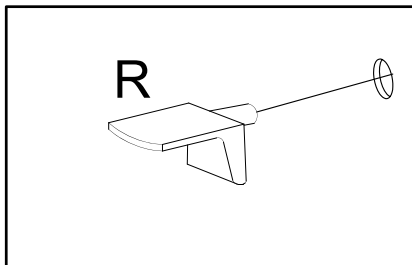
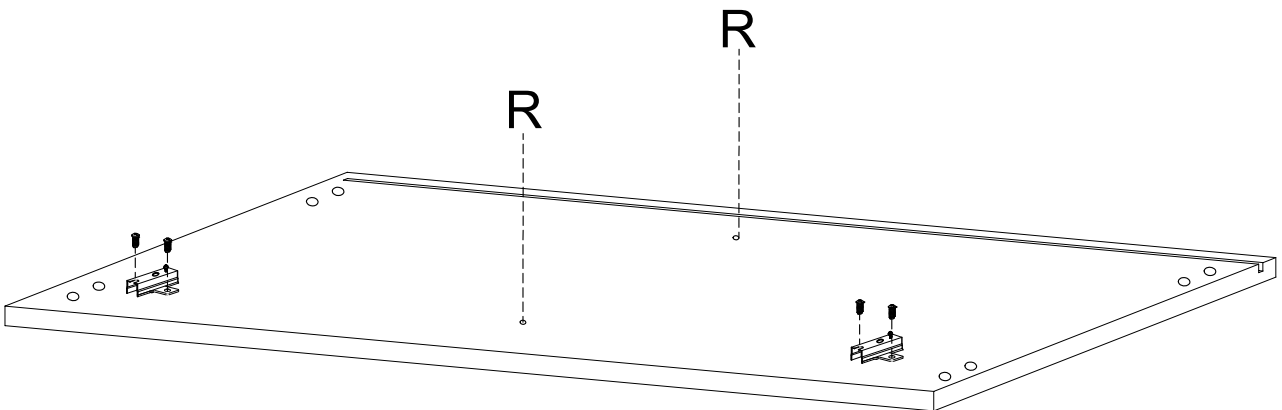
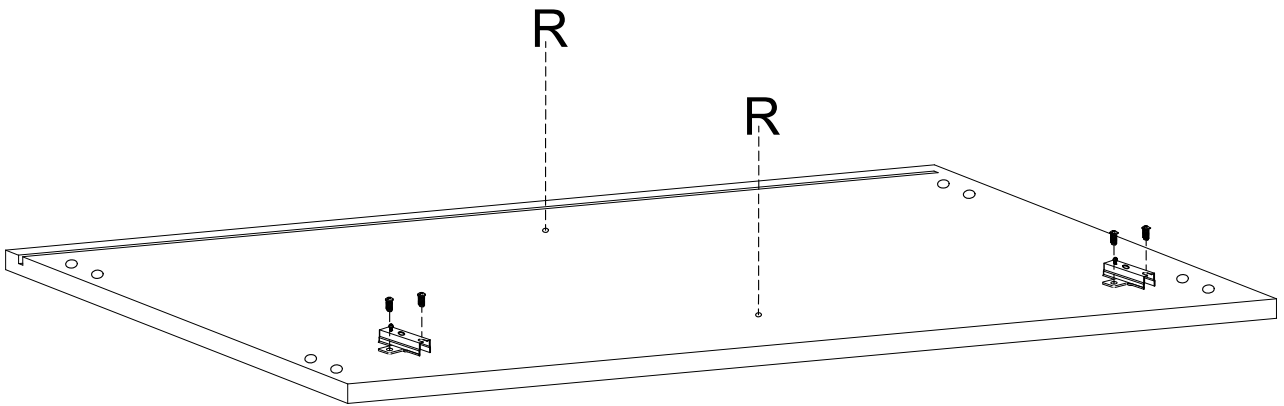

x4

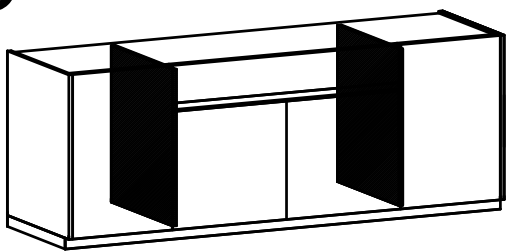

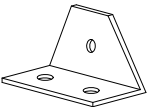
3

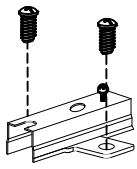
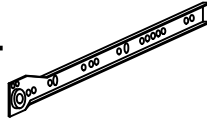
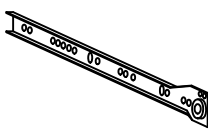

- B**  8x30 mm. x8
- P7**  x2
- L418**  4x18 mm. x4
- H4E**  x4
- CL**  x1
- CR**  x1
- E11**  6x11 mm. x4

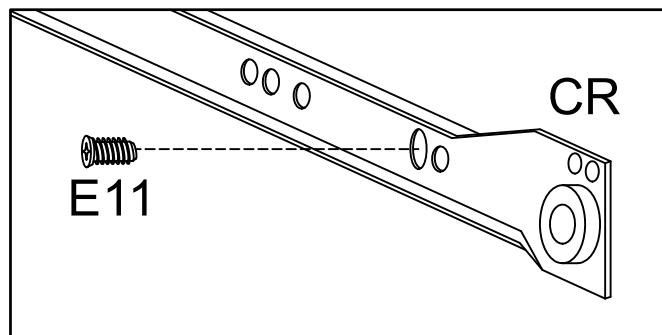
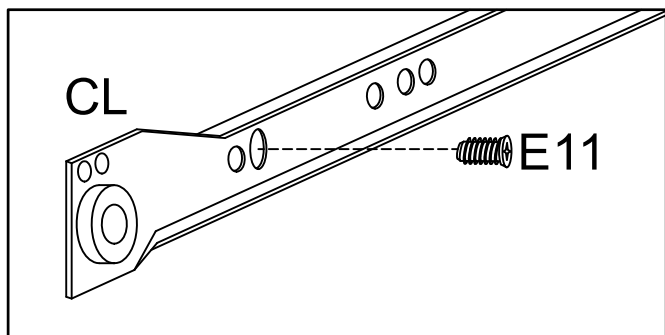
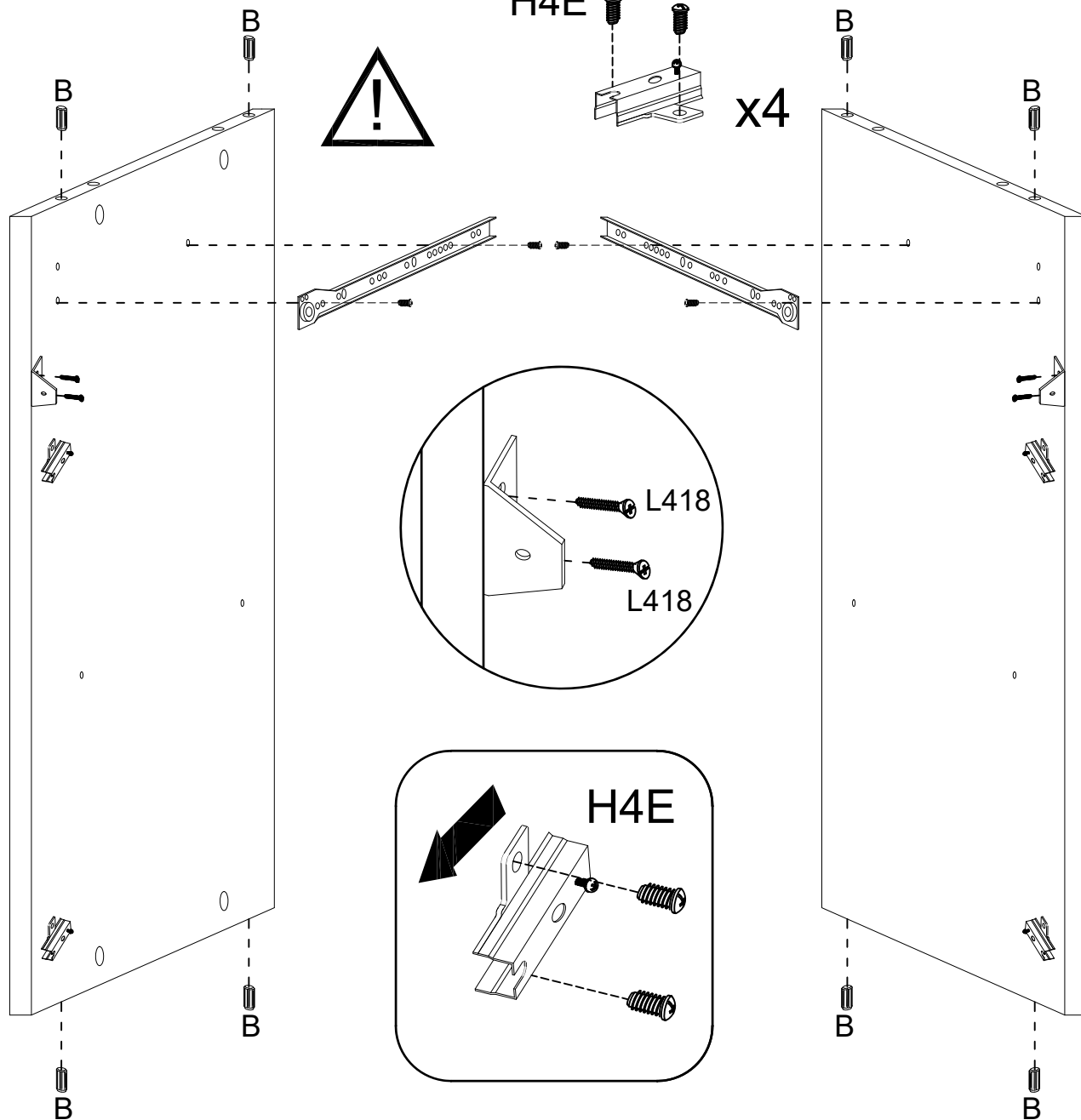

4

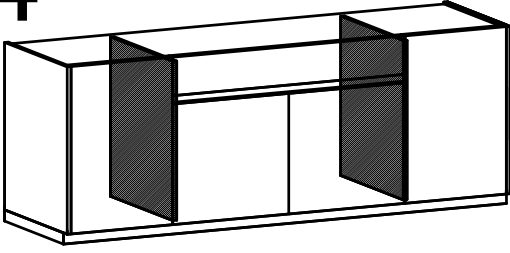

M9



6x9 mm.

x4

R2

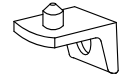

x4

D

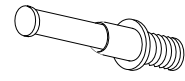

x8

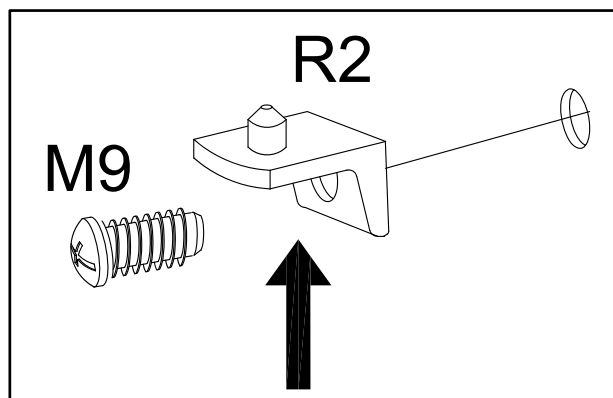
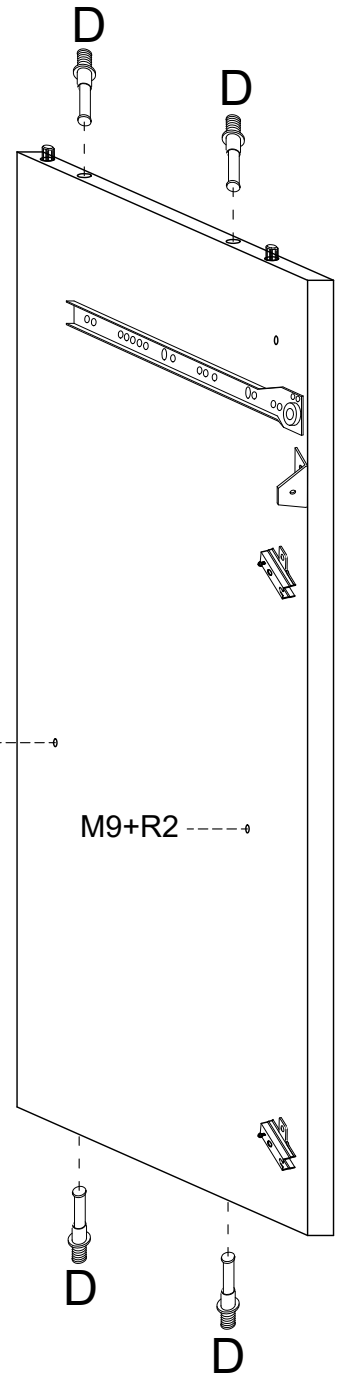
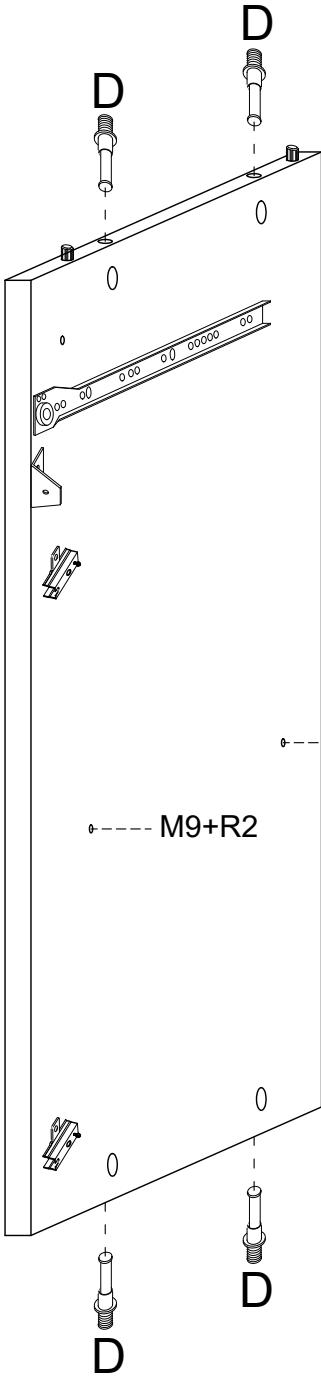

5

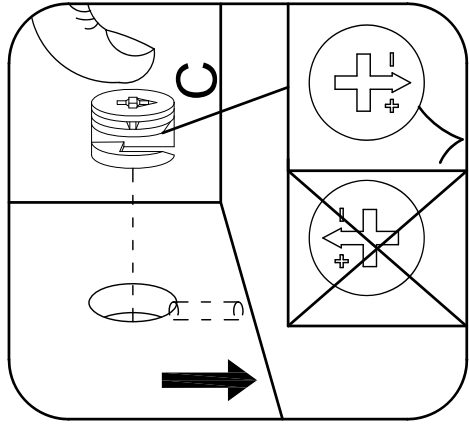
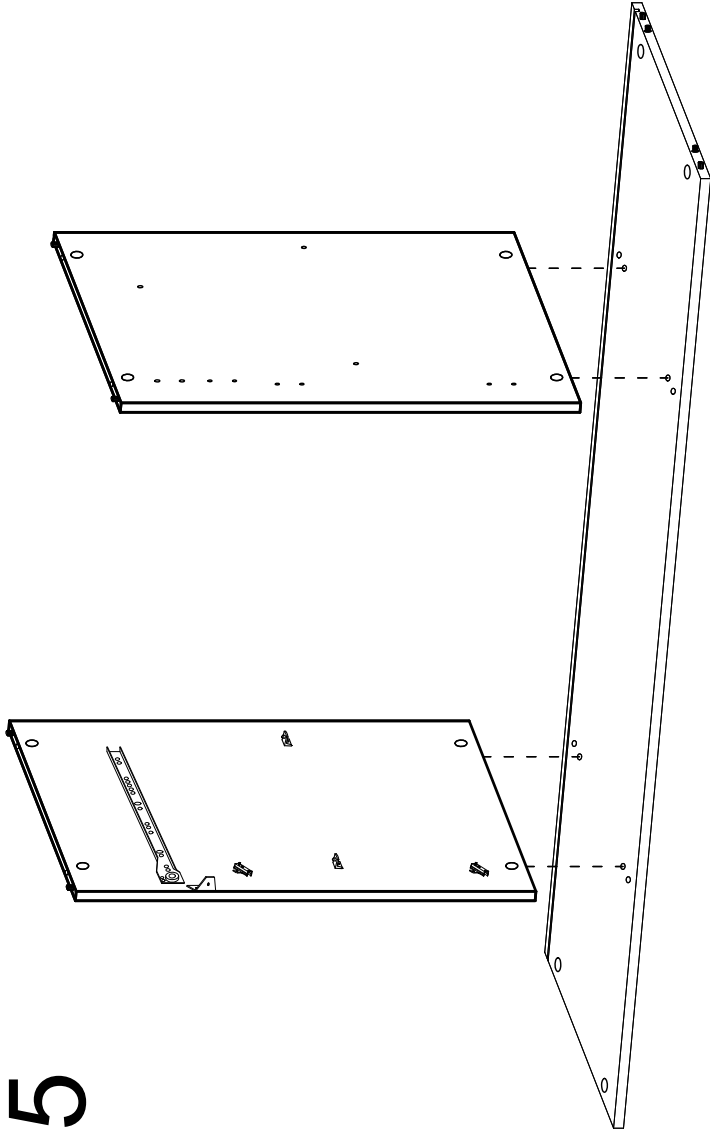

C

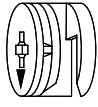

Ø15 x 12 mm

X4

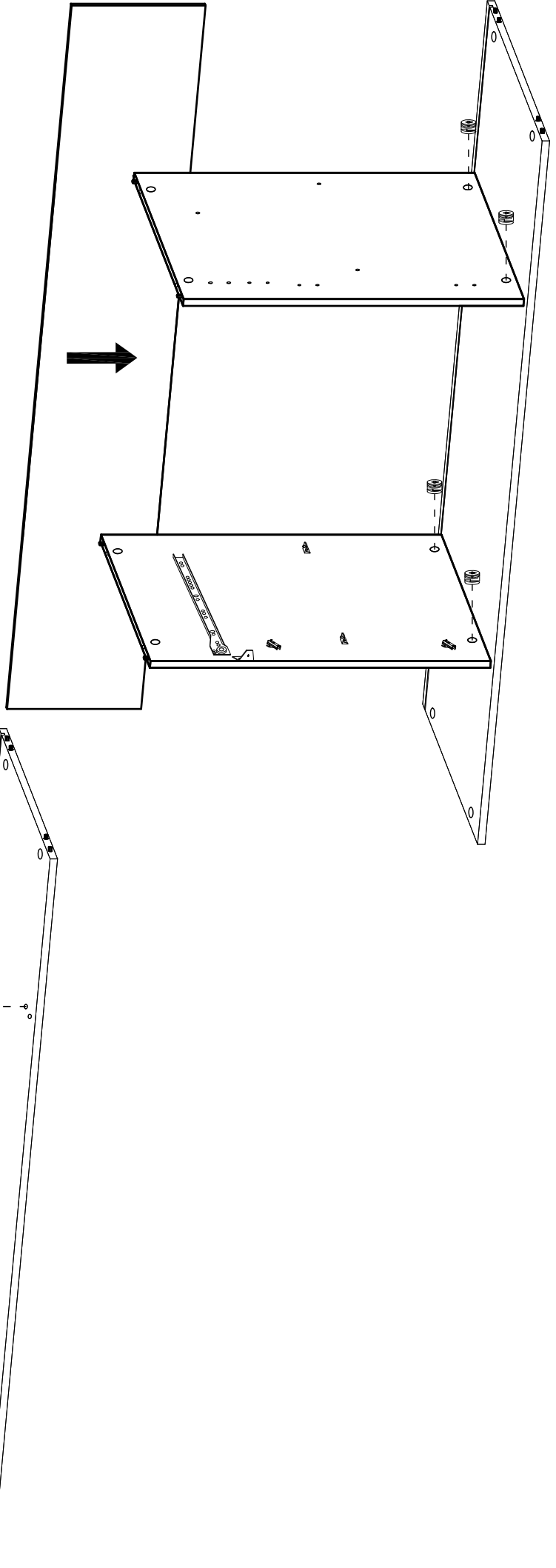

6



4x18 mm.



L418 X2

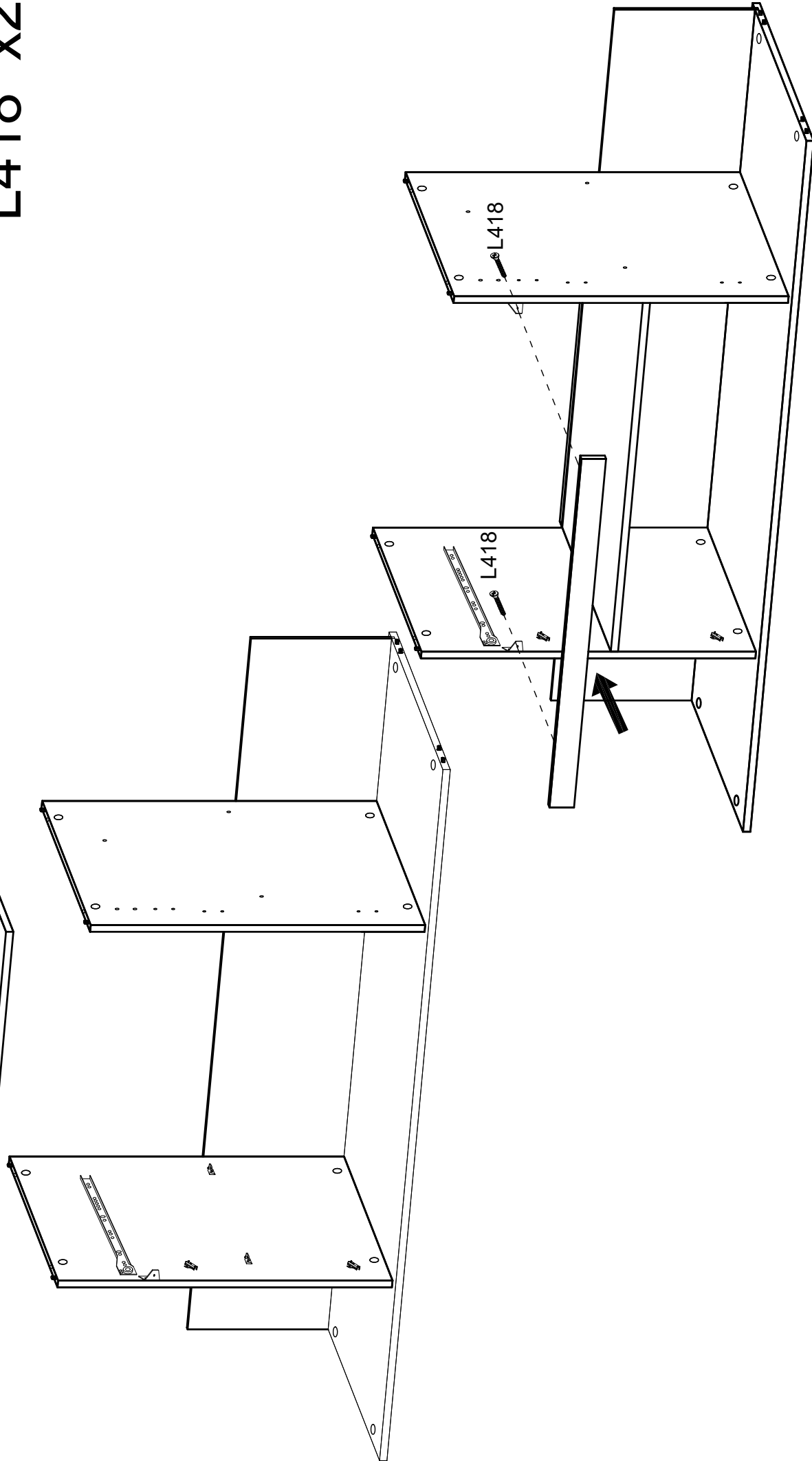

7

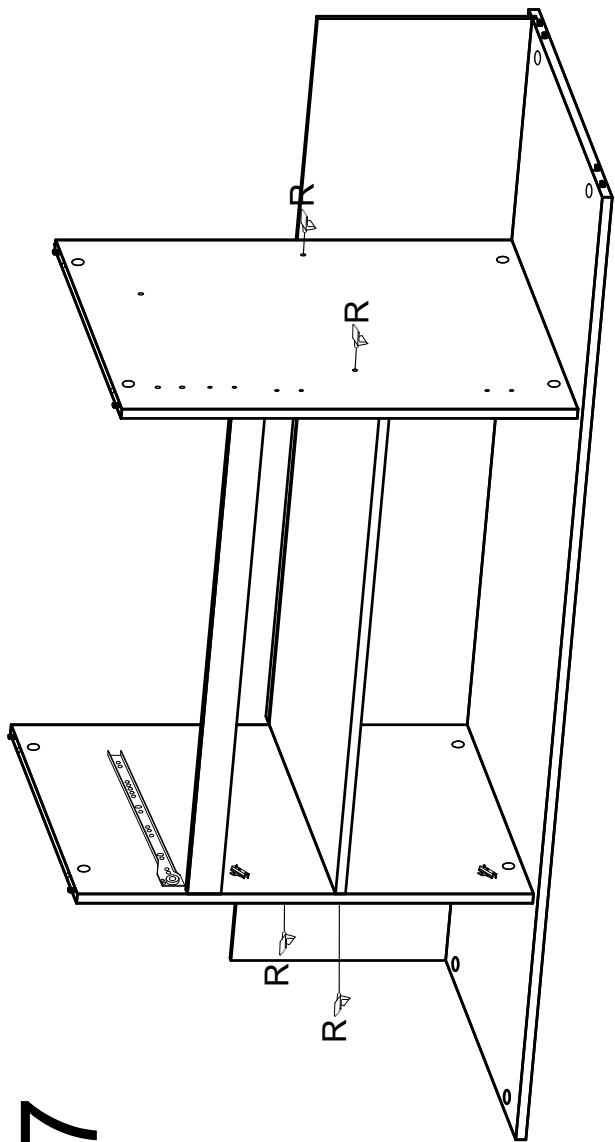

R

x4

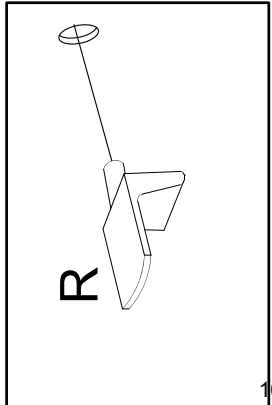
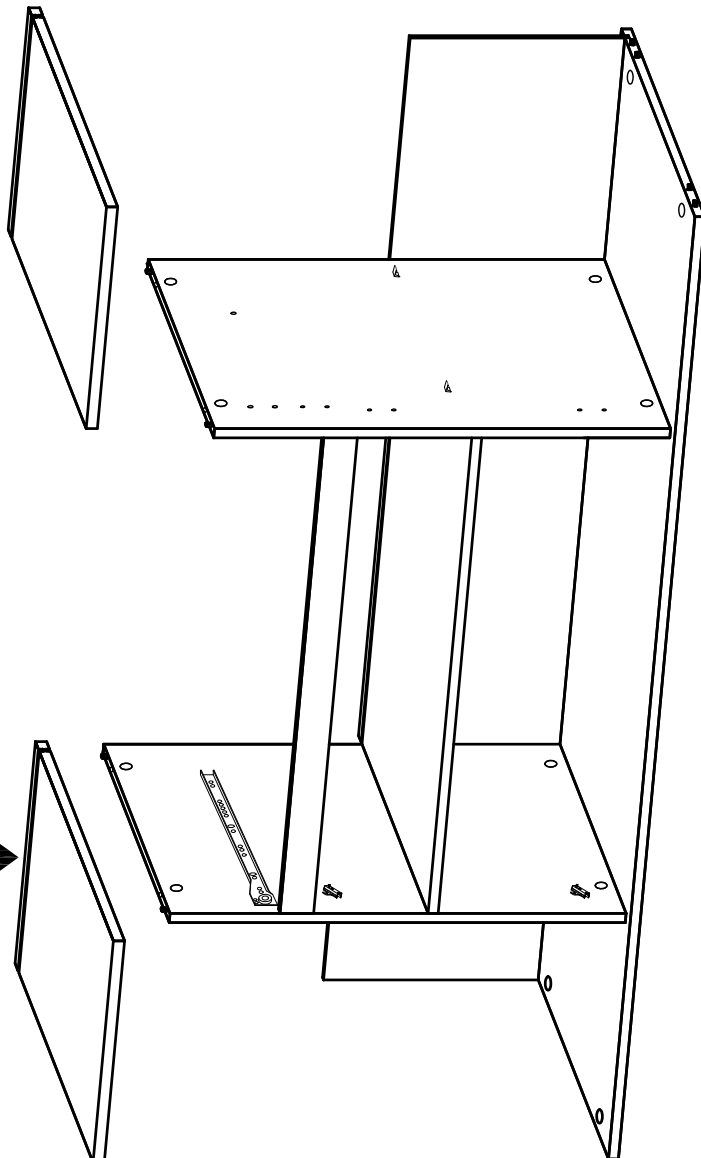
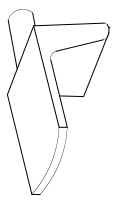

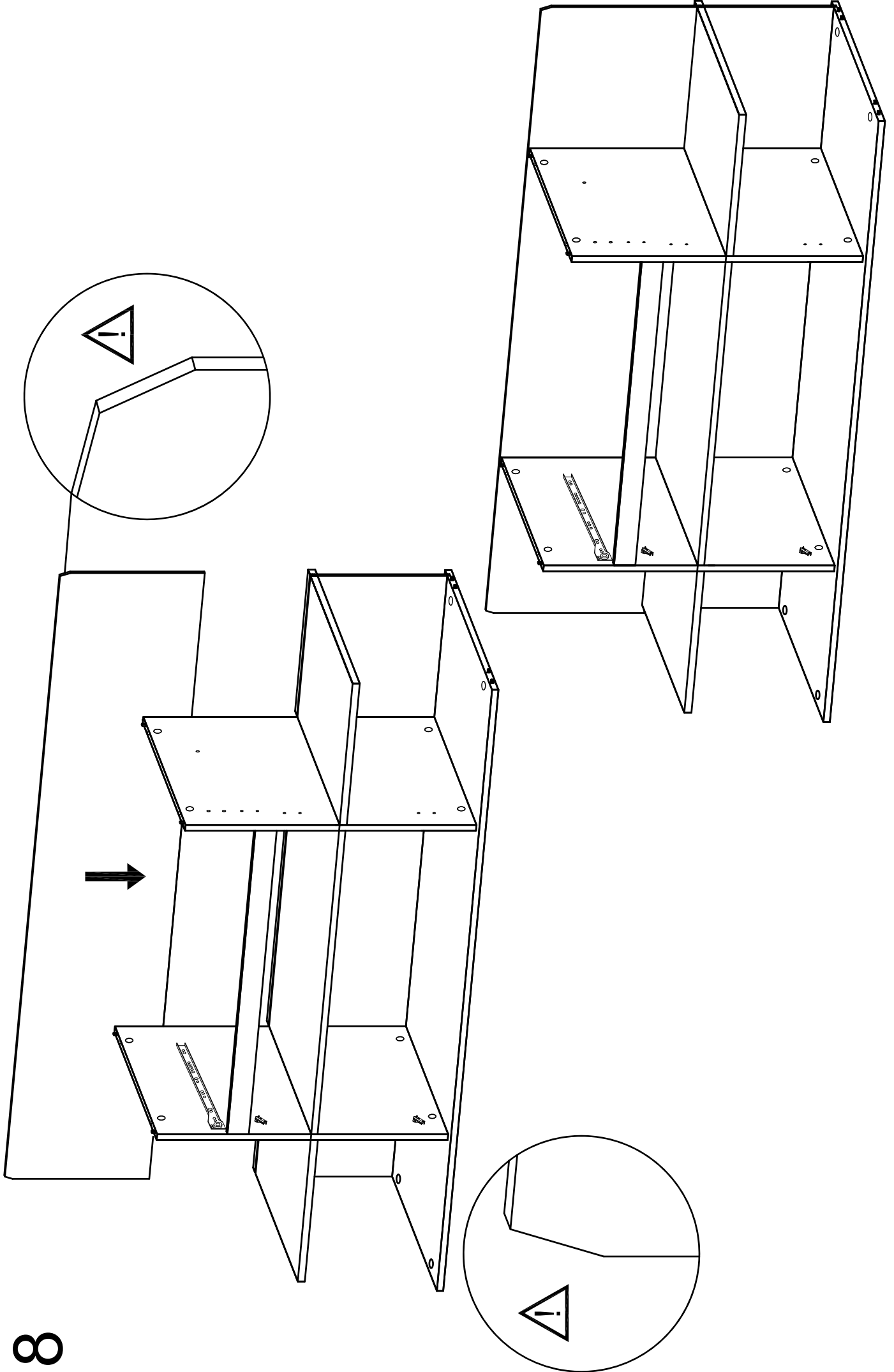

9

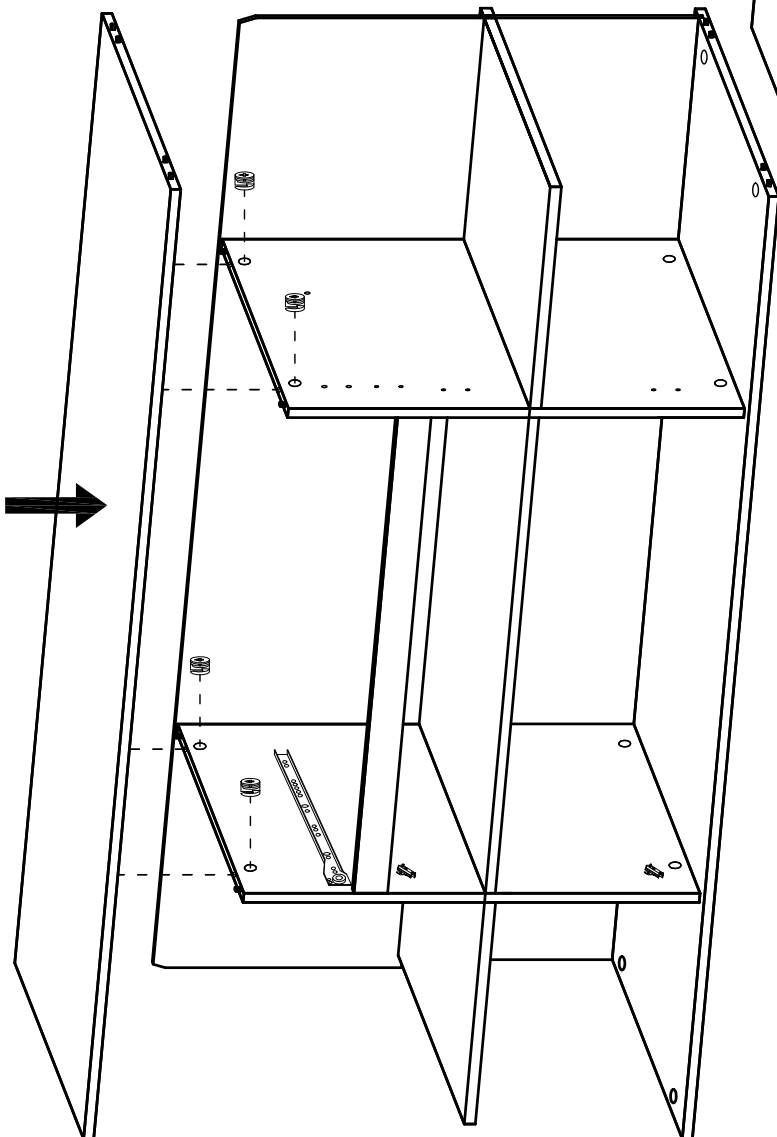

C

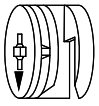

X4

∅15 x 12 mm

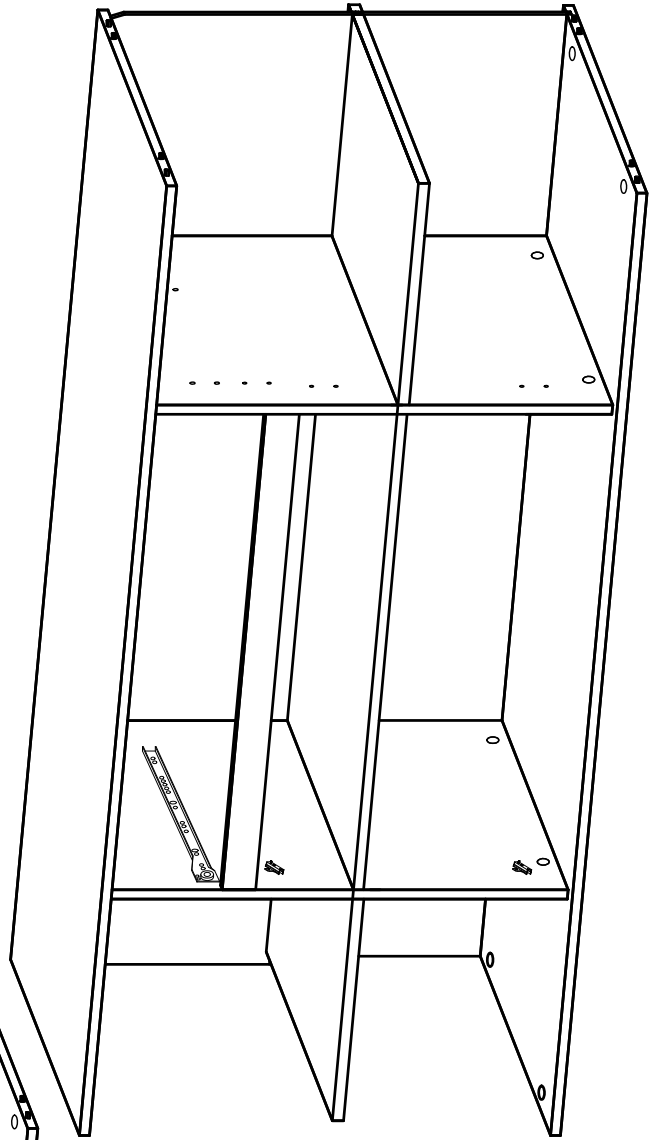
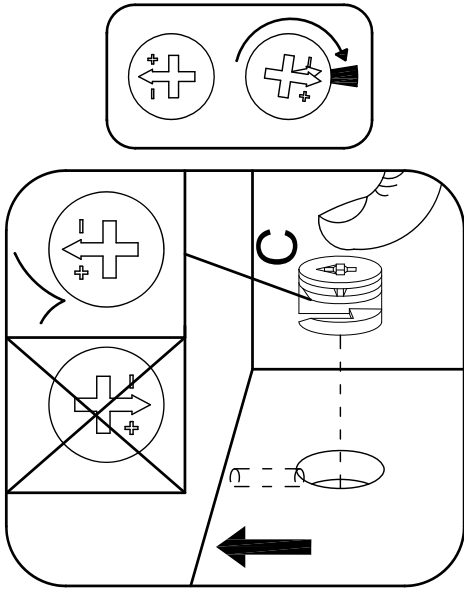

10

C

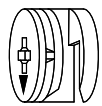

∅15 x 12 mm

x8

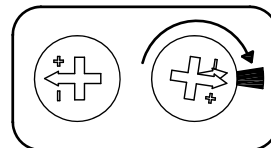
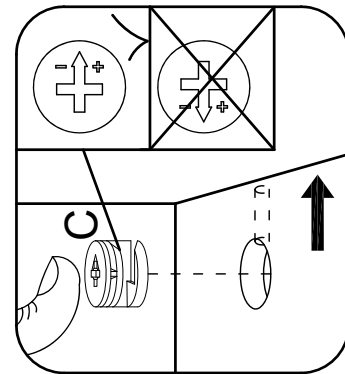
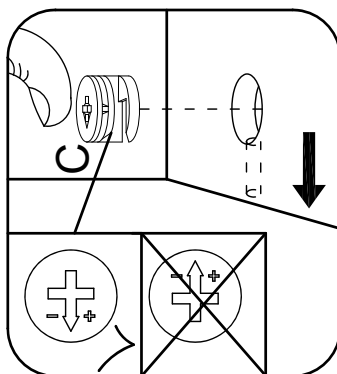
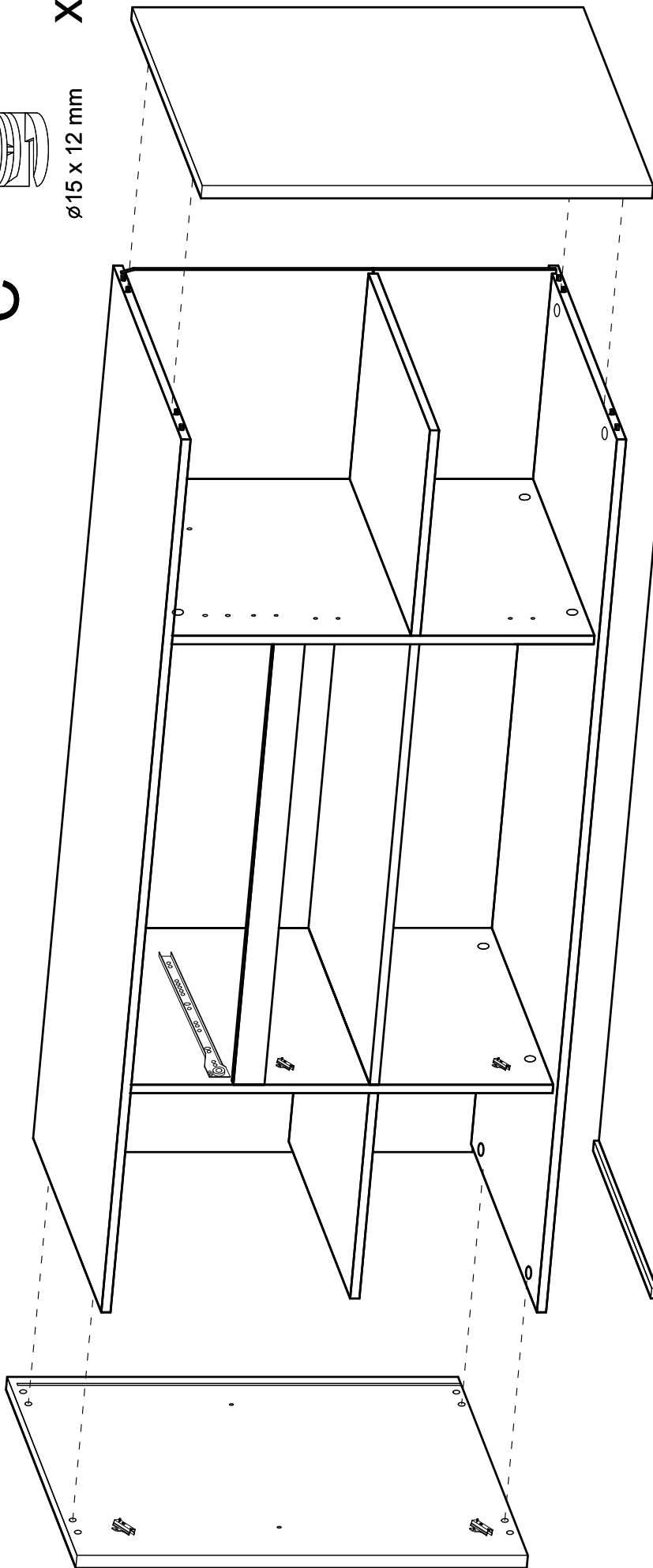

10

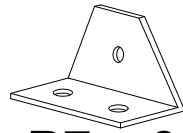

P7 x6

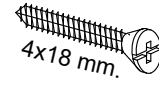

L418 x18

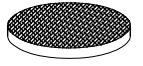

F3 x8

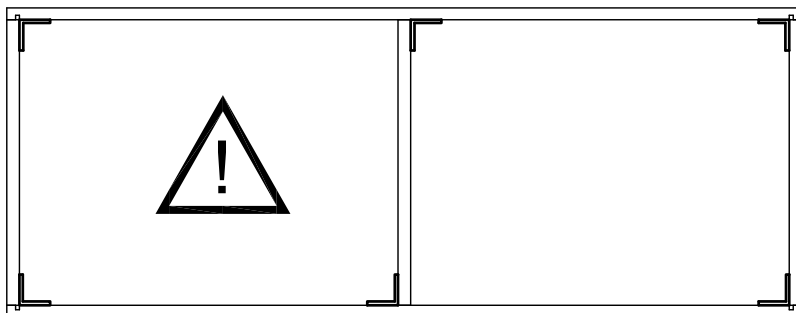
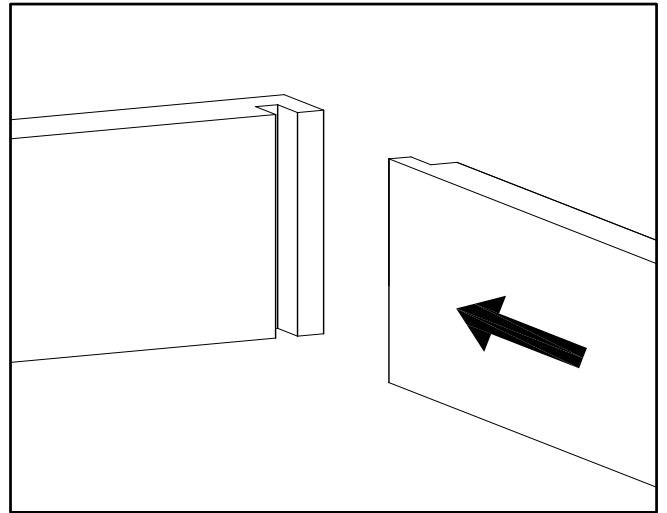
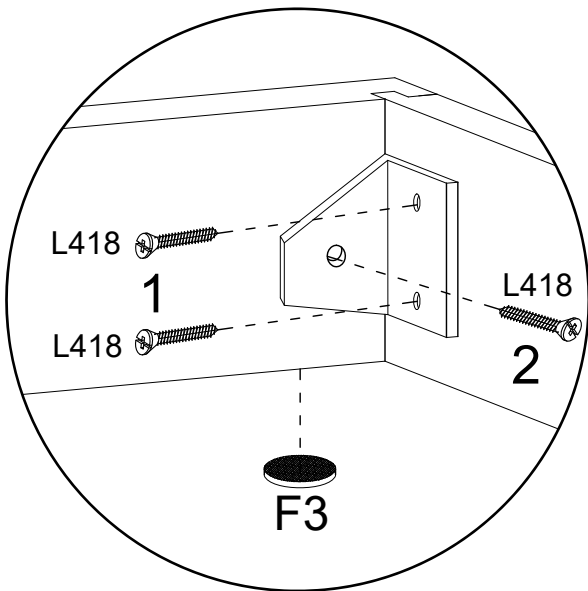
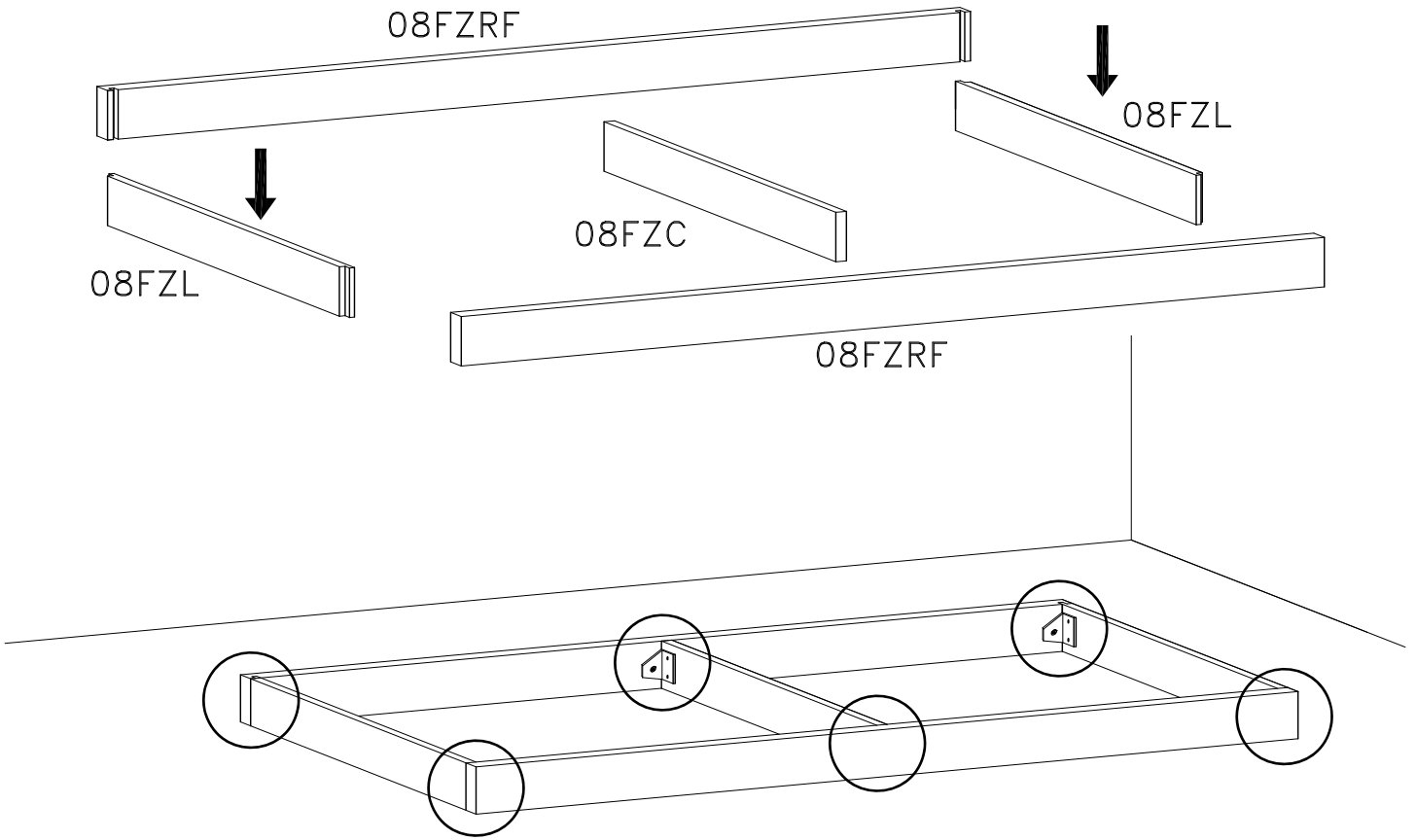

11

4x18 mm.

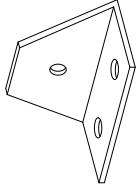

L418 x30 P7 x10

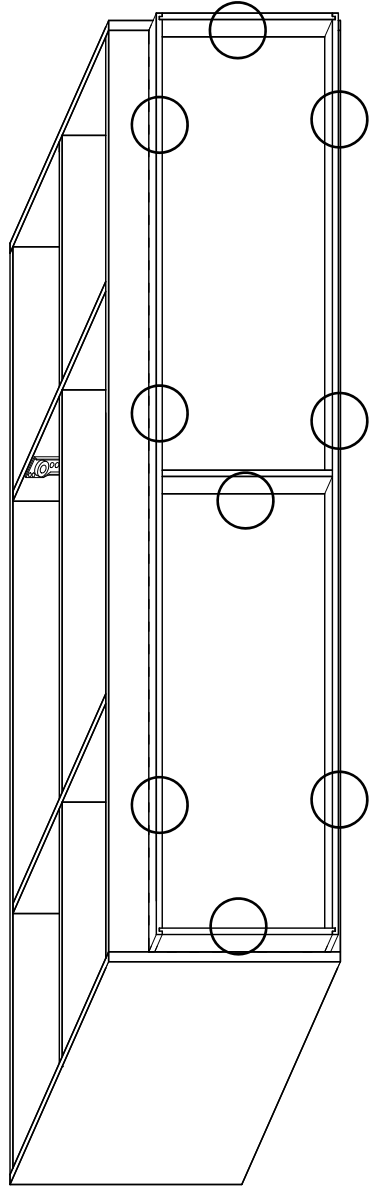
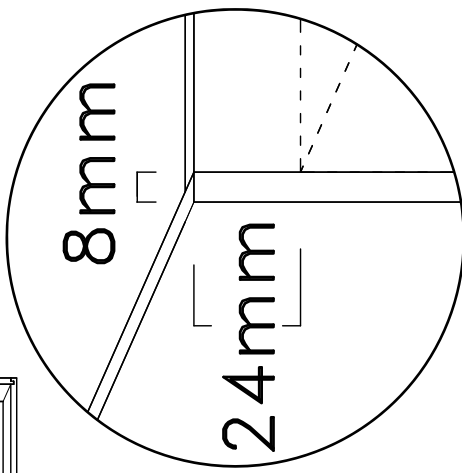
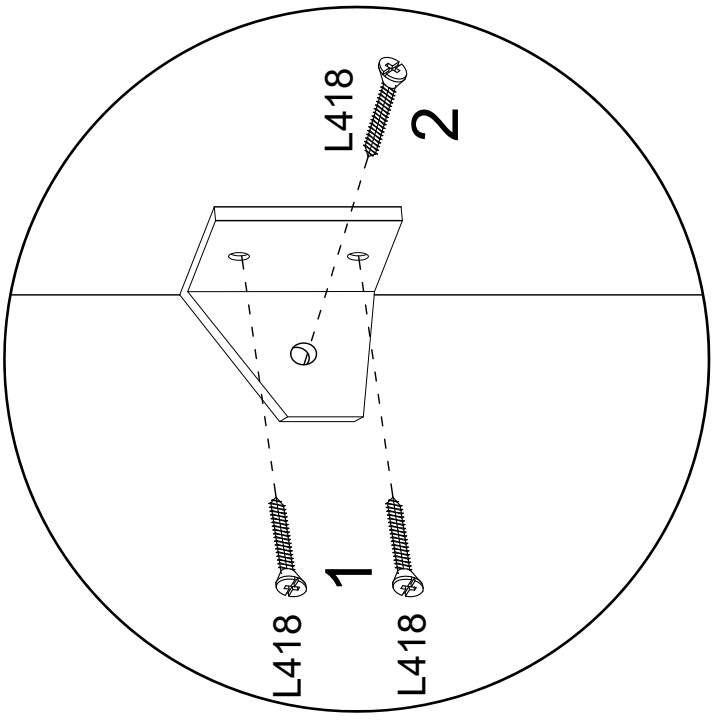
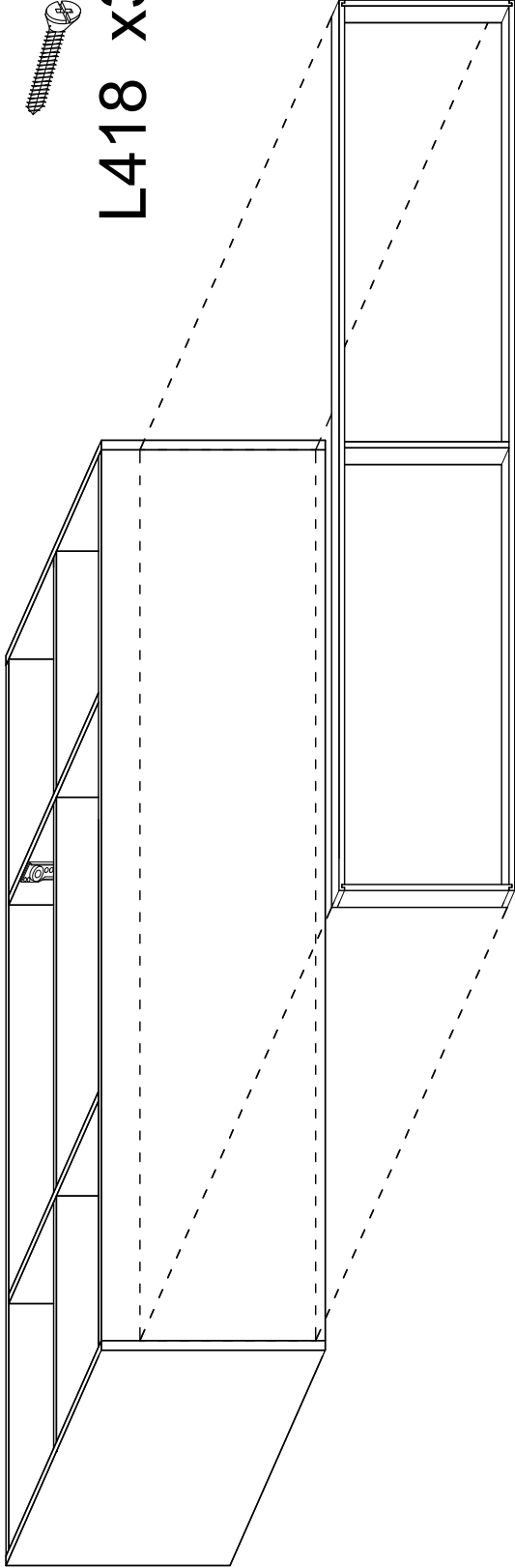
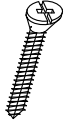

12

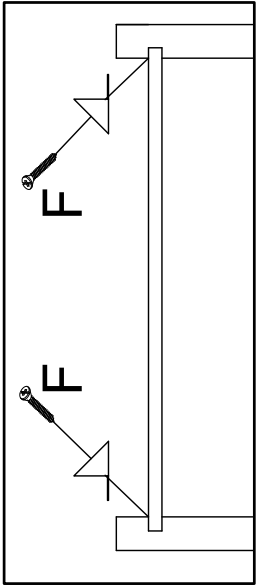
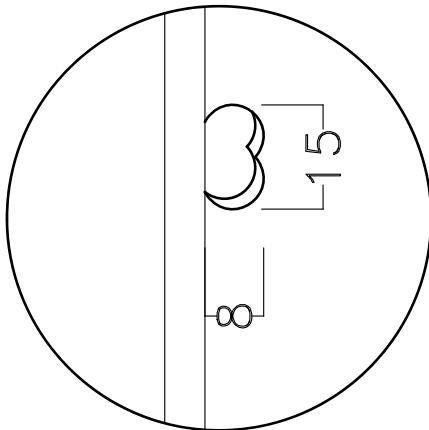
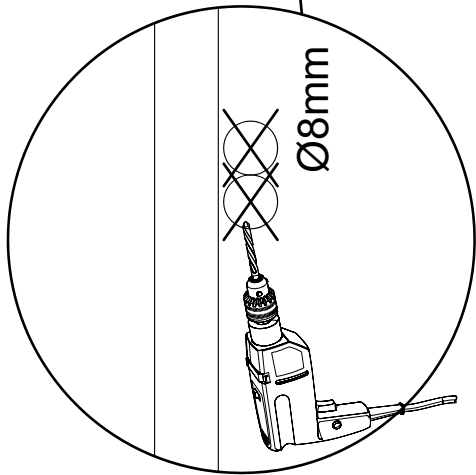

1023 mm.

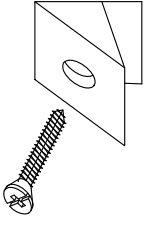
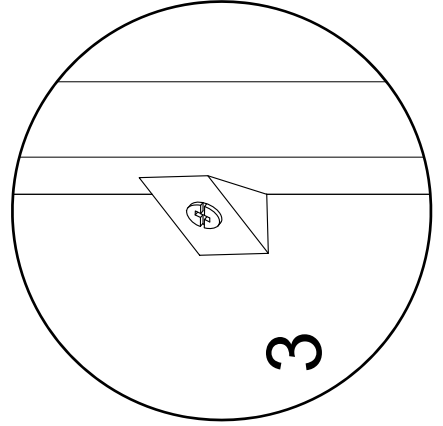
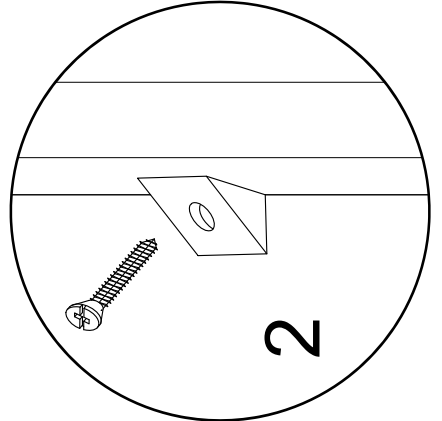
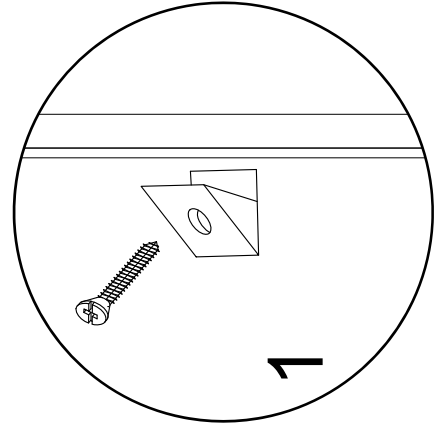
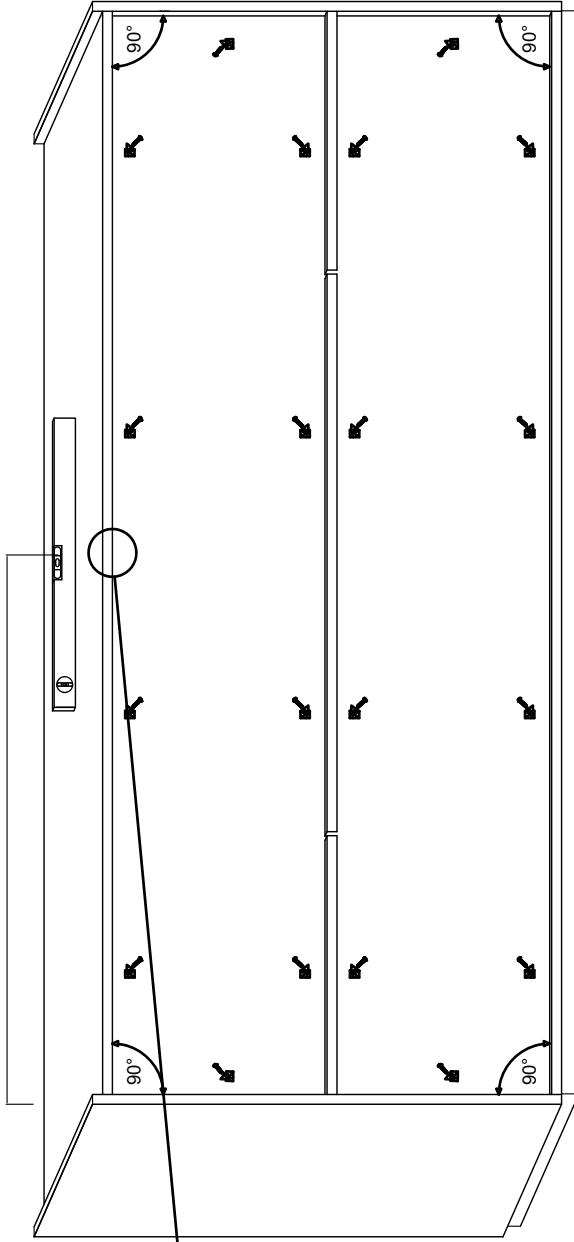

F x20

13

L3516

C1



ø12 mm.

x2



3.5x16 mm.

x4 D1

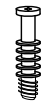

x2



P x2

DR

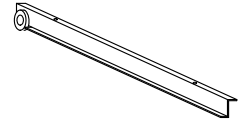

x1

DL

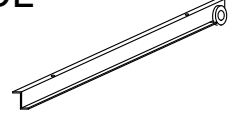

x1

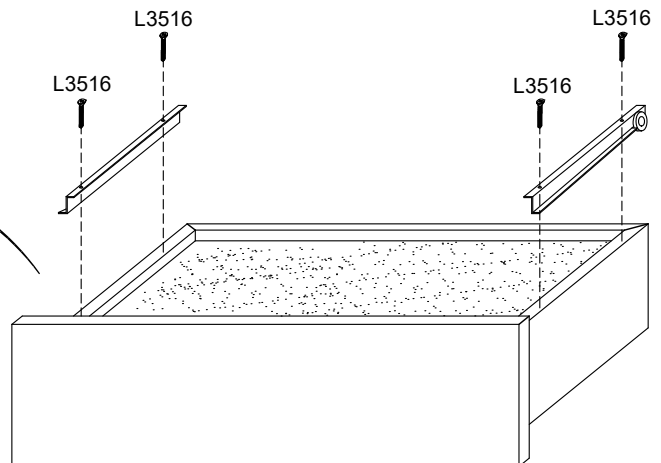
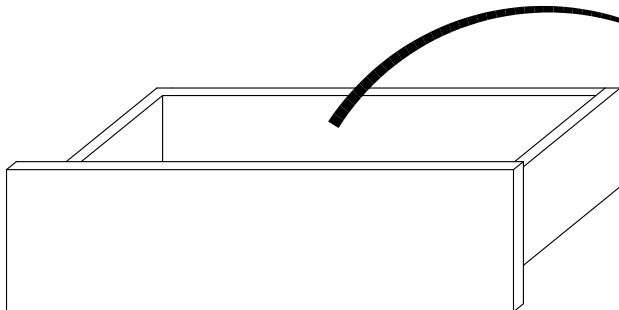
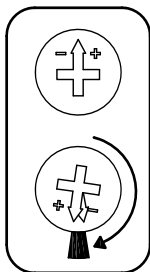
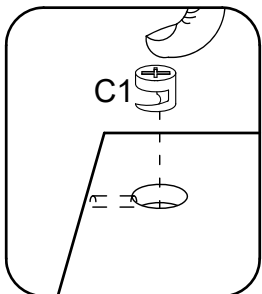
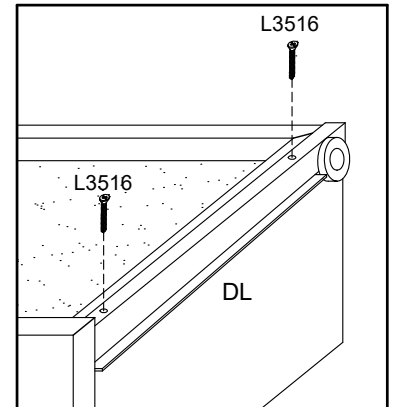
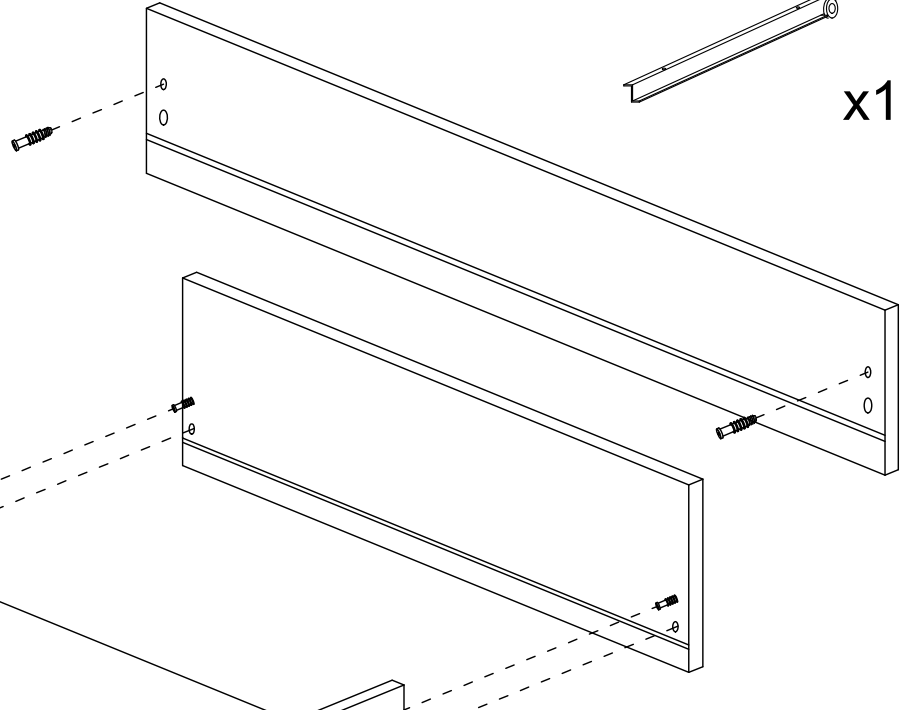
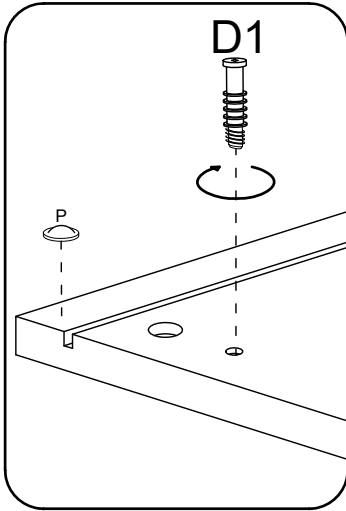
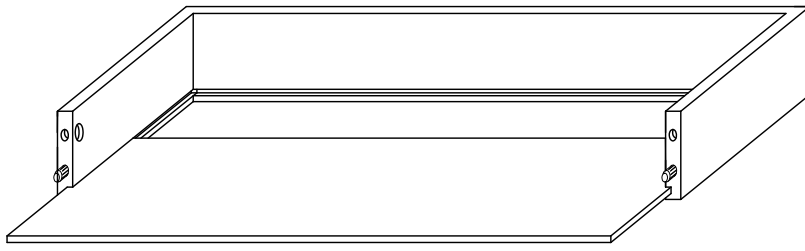

L3516 N3AST



3.5x16 mm. X2

X1

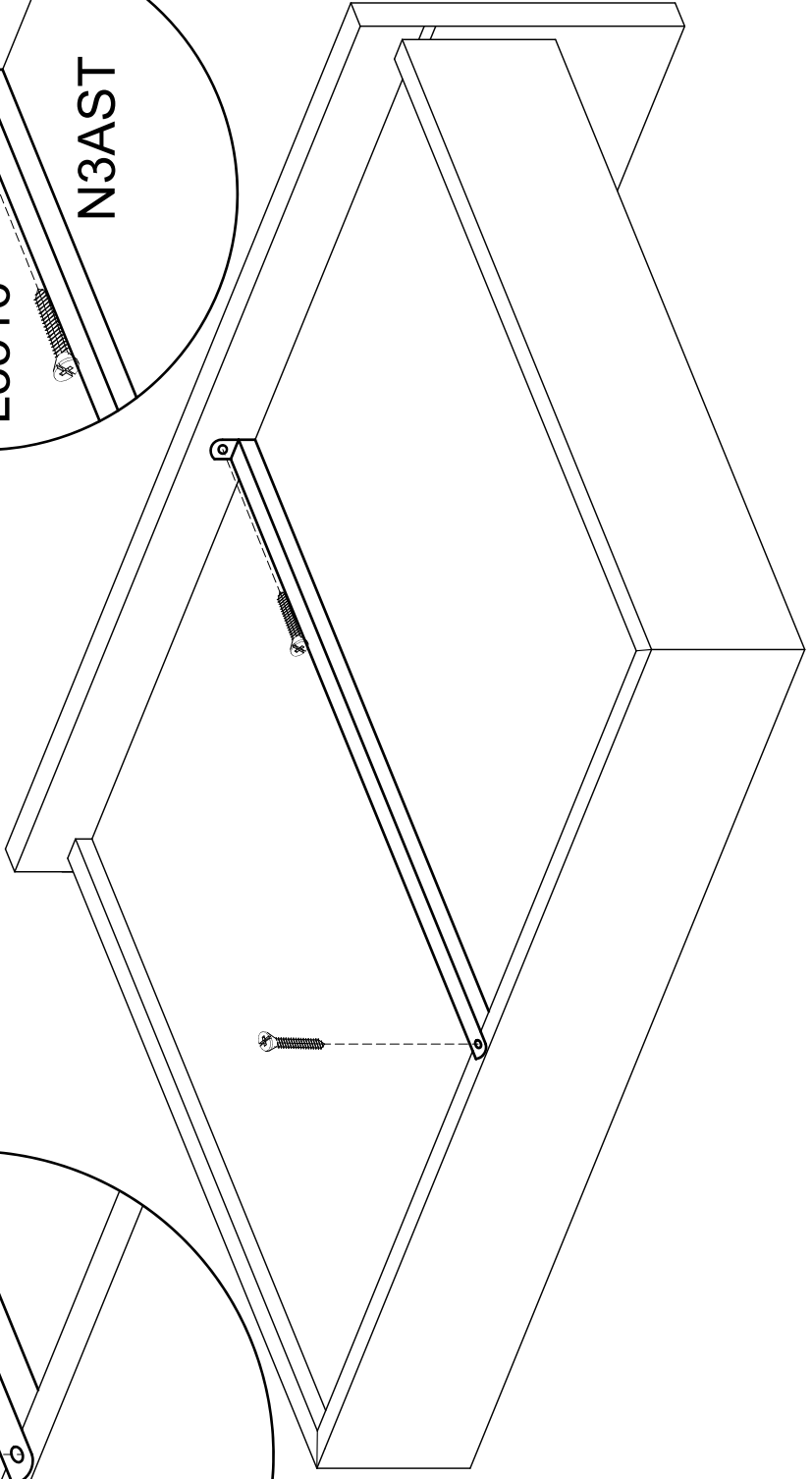
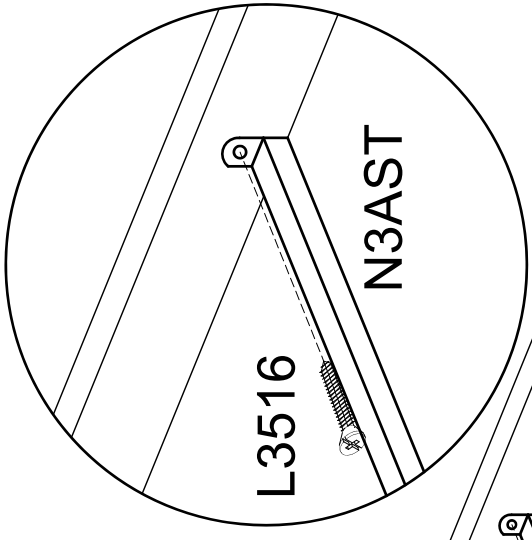
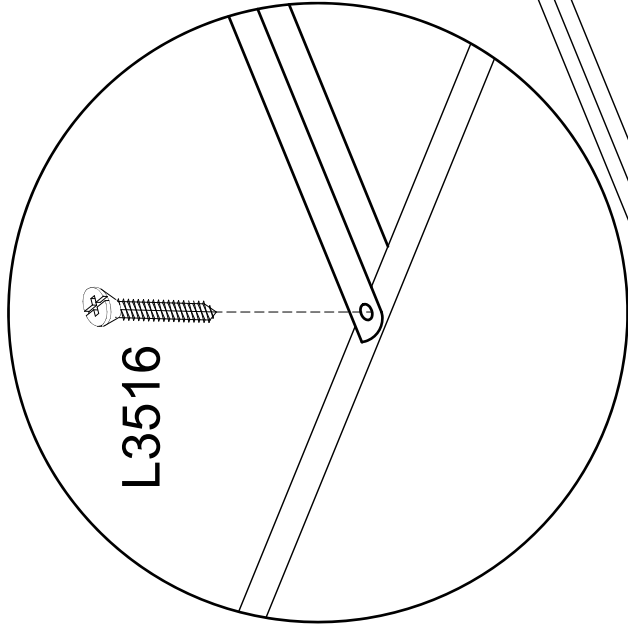
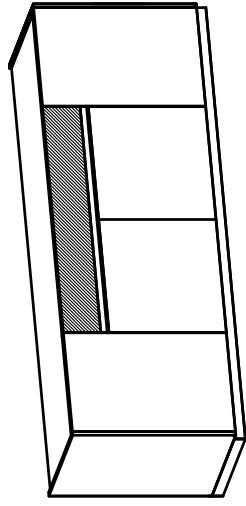
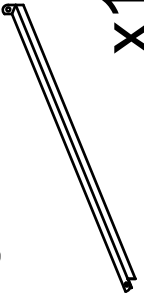

15

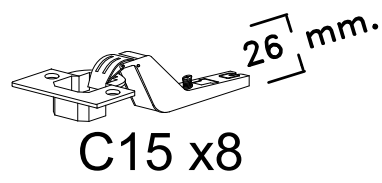
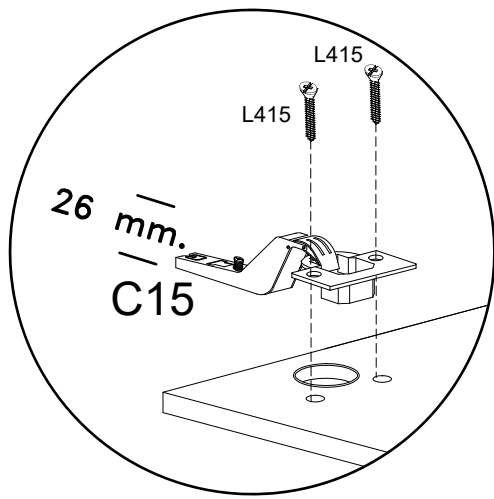

L415 x16

P



x8

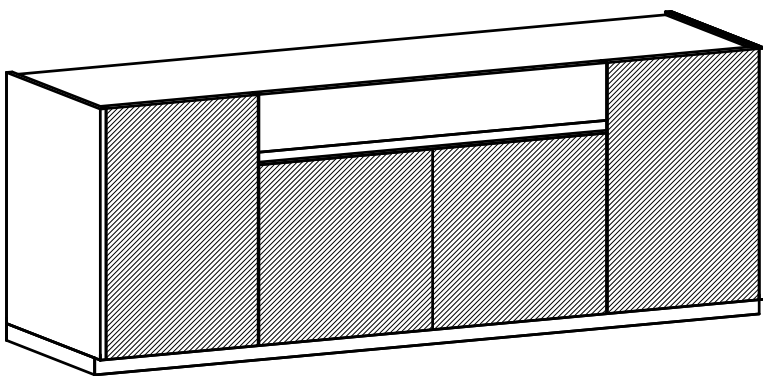
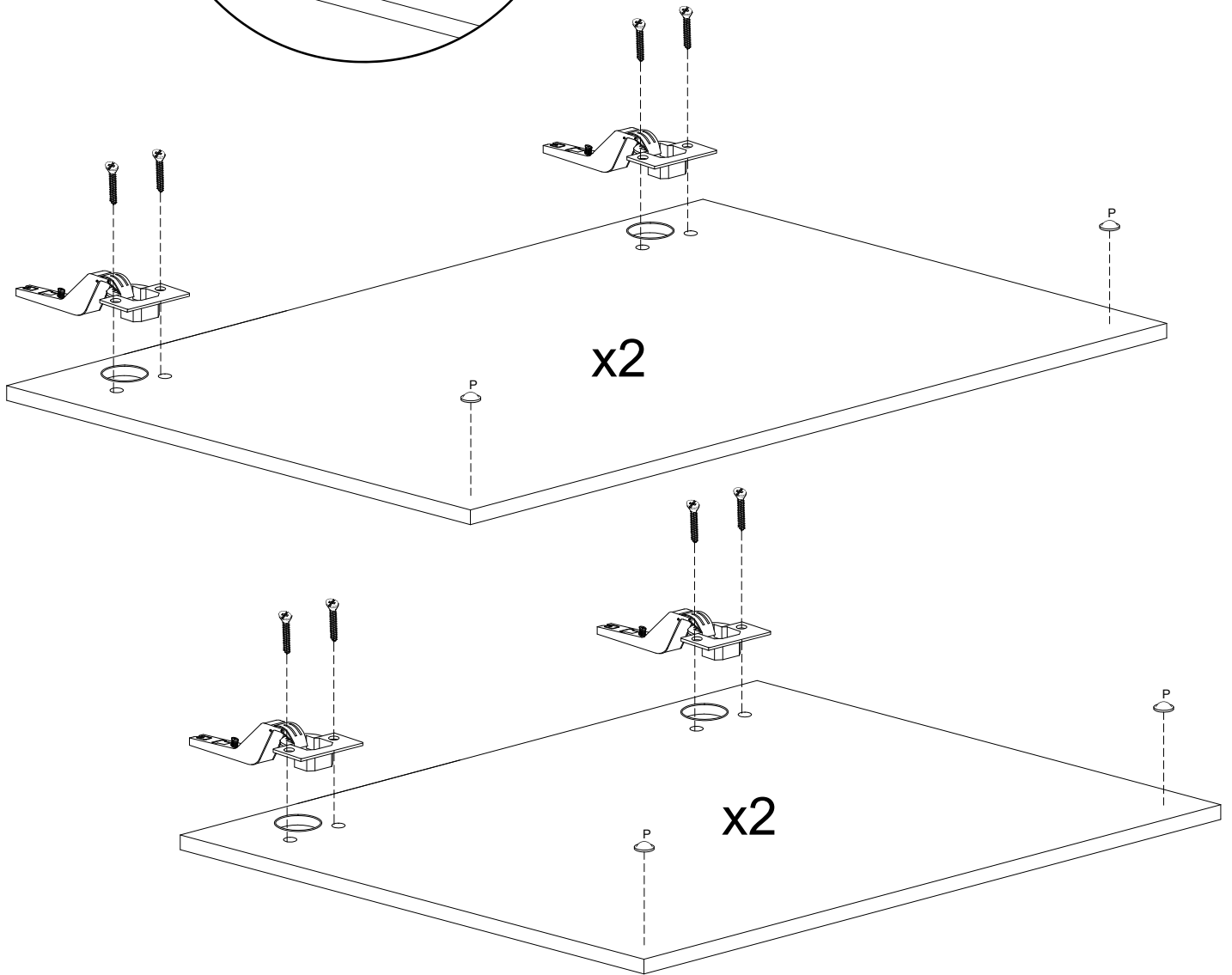

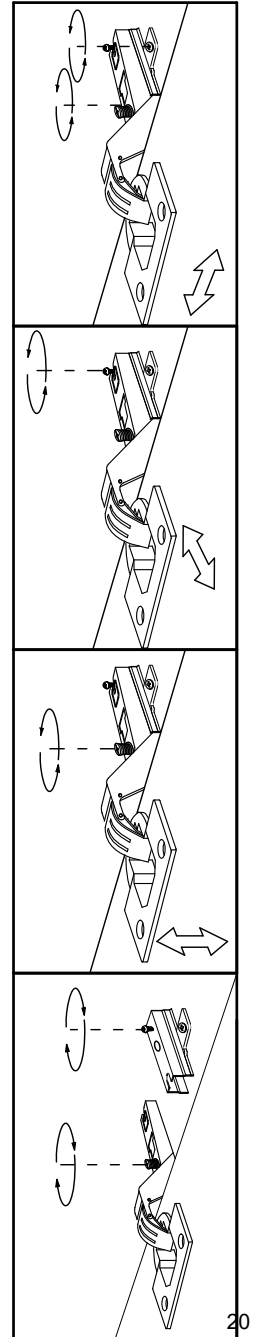
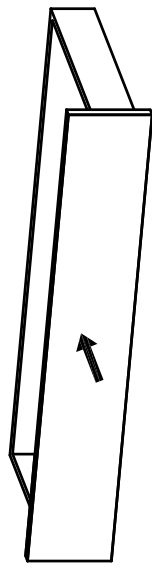
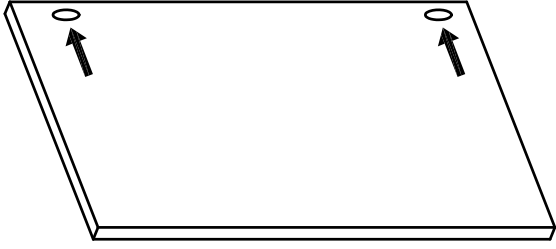
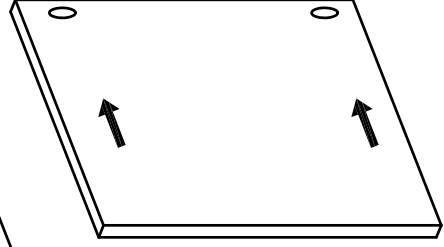
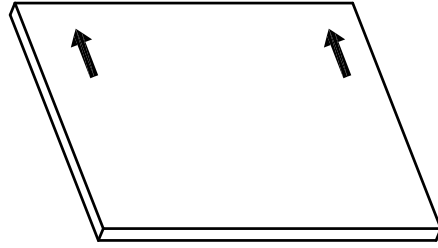
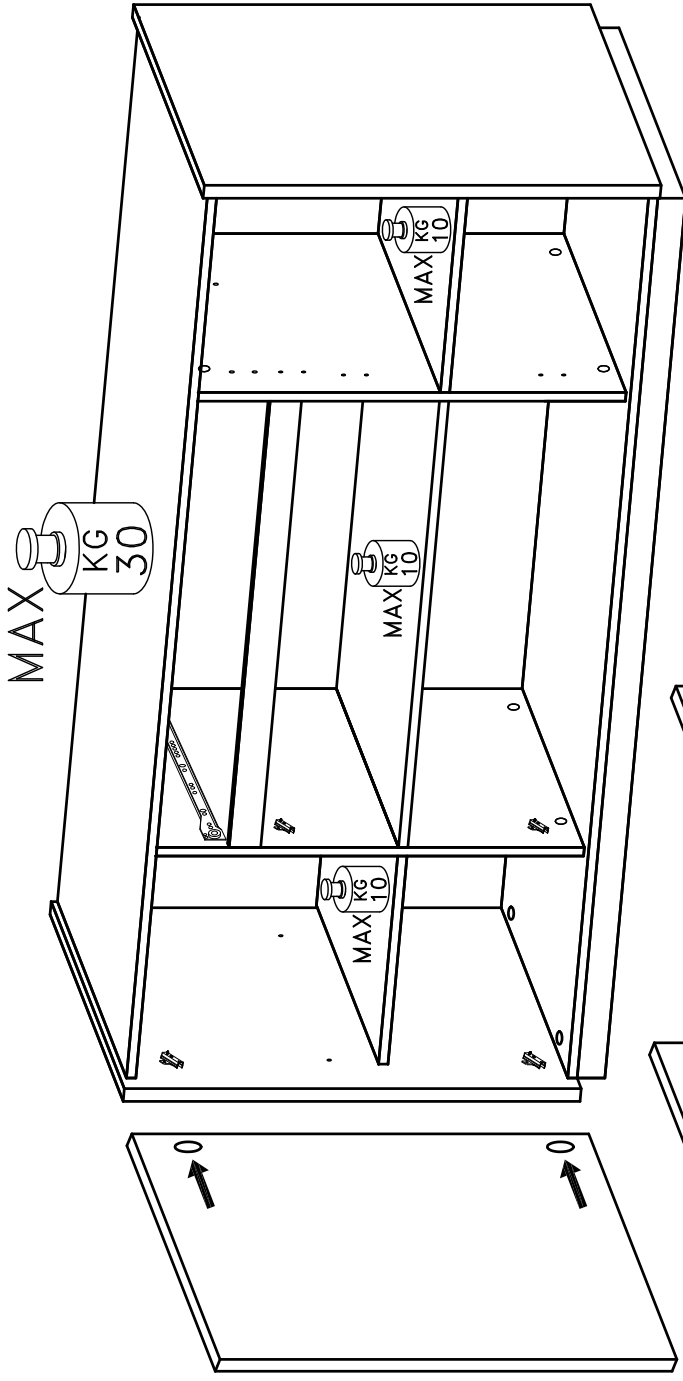

17

Cher client,
l'installation des meubles suspendus doit être effectuée par un personnel compétent.

Les fischers ne sont pas inclus dans la quincaillerie.
Choisir les types des fischers pour le fixage apte au mur.
S'assurer de l'adéquation du mur pour support sûr du meuble

Dear Customer

The assembling of the hanging elements must be done by a competent staff.

The fishers are not included in the hardware package.

Choose the fisher more suitable to the type of the wall.

Ensure the suitability of the wall for a secure support of the hanging element.

Sehr geehrter Kunde, die Montage der Haengeelemente muss von Fachpersonal ausgefuehrt werden! Bitte verwenden Sie eigene, der Beschaffenheit der Wand entsprechende Duebel. Zu Ihrer eigenen Sicherheit legen wir dem Beschlagbeutel keine Fischerduebel bei.

Gentile Cliente

Il montaggio dei pensili deve essere effettuato da personale competente.

I tasselli di fissaggio non sono compresi nella ferramenta.

Scegliere il tipo di tassello per il fissaggio più adatto alla tipologia di muro.

Assicurarsi l'idoneità della parete per un sostegno sicuro del pensile.

L418  x2
4x18 mm.

PST  x1

