

-41 -42

Montageanweisung / Installation instructions / Instruction de montage / Istruzioni di montaggio
montagehandleiding / Instrukcja montazu / Montaj talimatlar / Osszeszerelési útmutatót / Nàvod k montázi /
Nàvod na montaz / Instructiune de montaj / Инструкция по монтажу / Montaj talimatina / Monteringsanvisningar
Upute za montažu / Instrucciones de Montaje / Navodila za montažo

BASIC

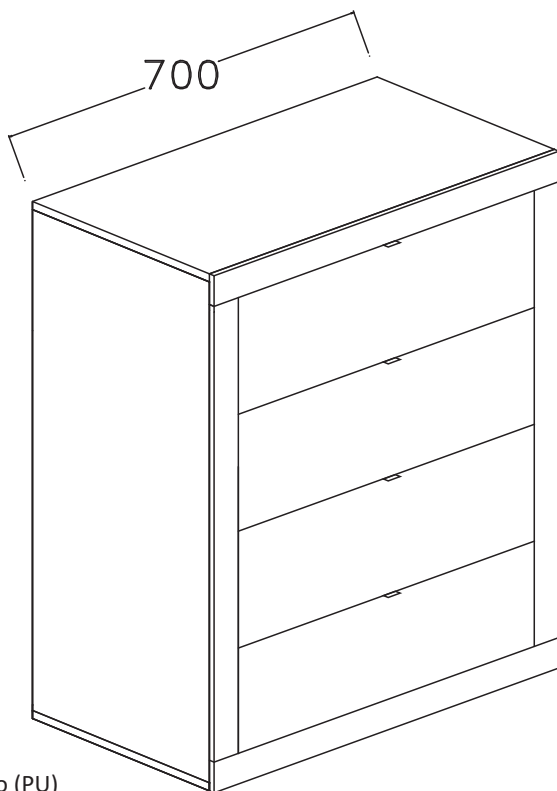
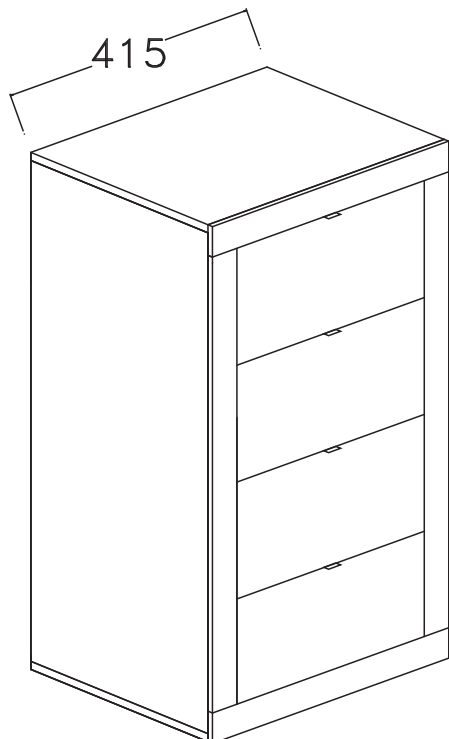
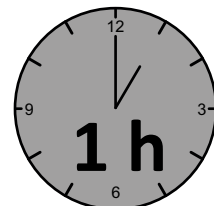
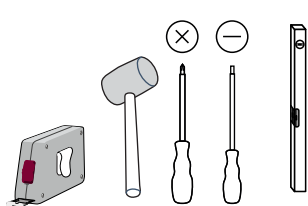

D – bitte lesen sie diese montageanleitung gut durch, Da wir für fehler, die durch falsche montage entstehen, Keine haftung übernehmen!

Gb – please read these installation instructions Through carefully as we cannot accept any liability For faults occurring as a result of incorrect installation!

Cz – přečtěte si prosím pozorně tento návod k montáži, Aby jste předešli chybám vzniklých špatnou montáží, Za které neručíme!

F – veuillez lire attentivement cette notice de montage, Car nous déclinons toute responsabilité en cas d'erreurs Découlant d'un montage erroné !

I – prego leggere attentamente le istruzioni per il montaggio, Poiché decliniamo qualsiasi responsabilità Per difetti derivanti da montaggio errato.

S - läs monteringsanvisningarna noggrant. Vi avsåger oss allt ansvar för defekter som Uppstår p.g.a. Felaktig montering.

Hr – pažljivo pročitajte upute za montažu, Jer otklanjamo svaku odgovornost za pogreške Nastale uslijed pogrešne montaže.

Slo – prosimo, da pozorno preberete navodila za montažo, Saj zavračamo vsakršno odgovornost za napake, Ki bi nastale zaradi napačne montaže.

Nl – leest u alstublieft deze montagehandleiding goed door, Voor fouten door verkeerde montage zijn wij niet verantwoordelijk.

Pl – prosze uwaznie zapoznac sie z instrukcja montazu, Poniewaz nie ponosimy odpowiedzialnosci za niewlasciwy montaz.

HU – Kérjük, olvassa el figyelmesen ezt az összeszerelési útmutatót, mert a helytelen összeszerelésből a dódó hibákért nem vállalunk felelősséget!

SK – Prosíme, dobre prečítajte si tento návod na montáž, pretože nepreberáme žiadne ručenie za chyby, ktoré vzniknú na základe chybnej montáže!

RO – Vă rugăm să cititi cu atenție aceste instructiuni de montaj deoarece nu preluăm garanția pentru defecte ce apar datorită unui montaj incorect!

RUS – Пожалуйста, внимательно ознакомьтесь ù с данной инструкцией по монтажу, поскольку мы не несем ответственности за ошибки, причиной которых является неправильный монтаж.

TU – İlkonce kullanma klavuzunu iyi okuyun, yalnız montaj yapasanız bunun sorumlusu biz degiliz.

ES – Se ruega leer con atención las instrucciones de montaje debido a que declinamos cualquier responsabilidad por defectos derivados de un montaje erróneo.

LC S.p.A
Via del Piano s.n
61030 Isola del Piano (PU)
Italia
<http://www.lcmobili.com/>

el.41

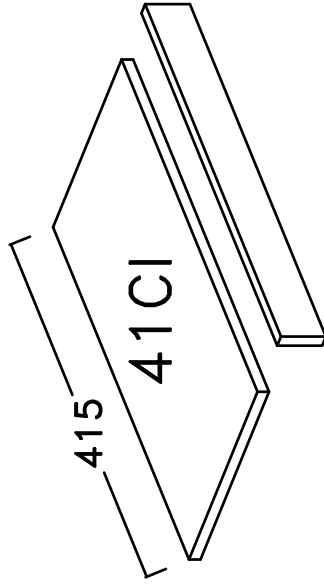
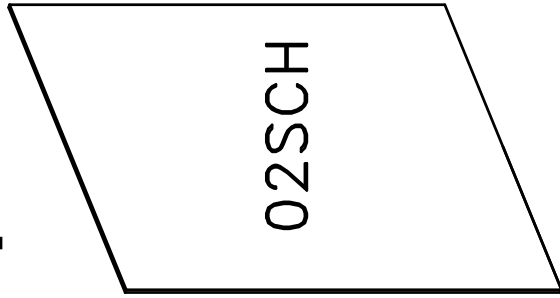

70FASI x2

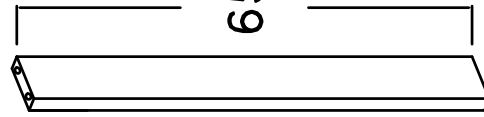
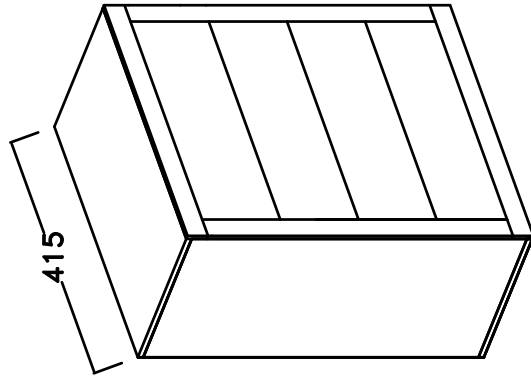

110TFAL x2

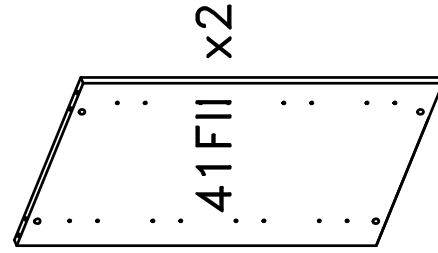
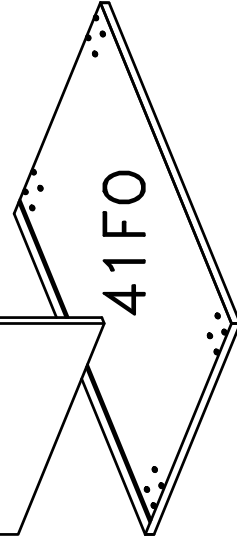
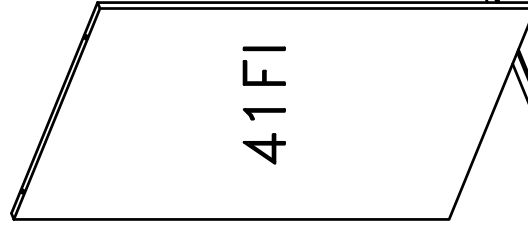
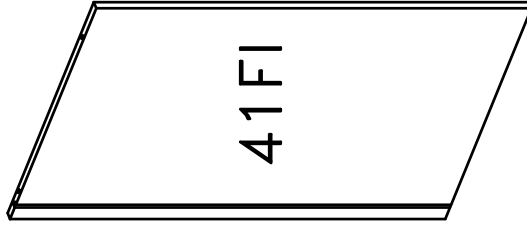

41SPON x4

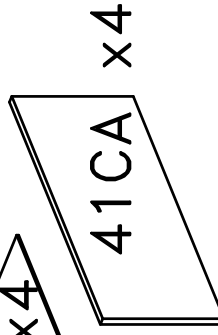
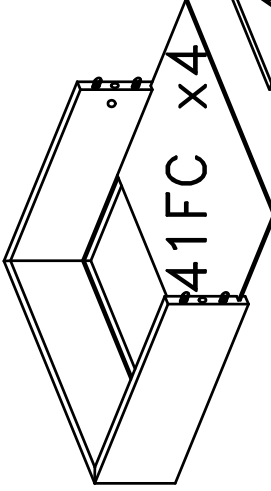

el.42

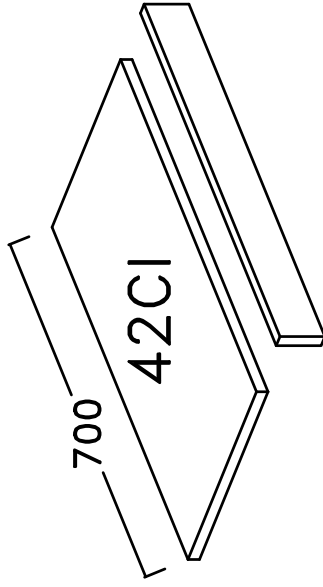
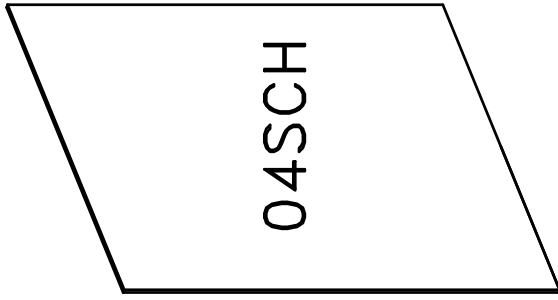

02FASI x2

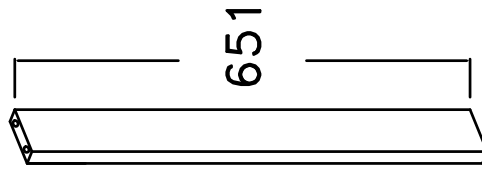
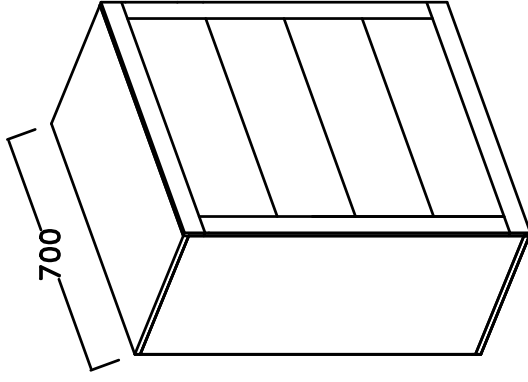



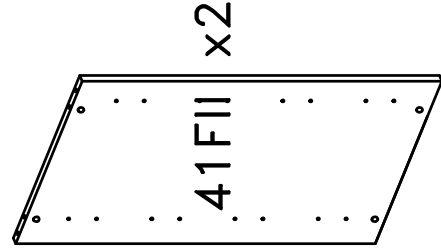
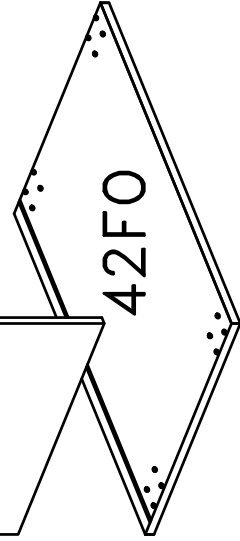
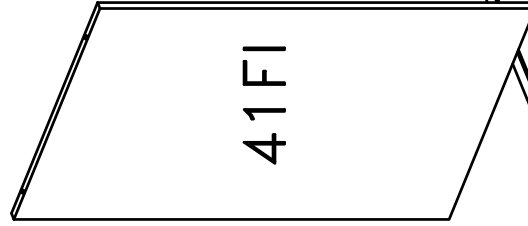
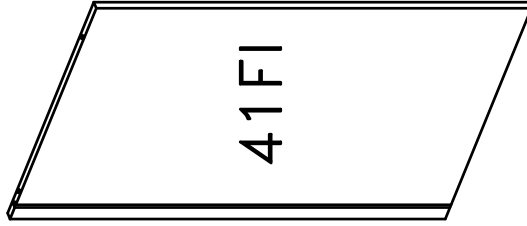



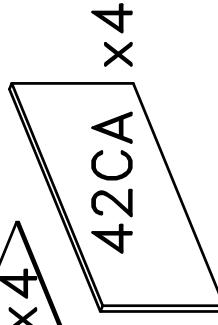
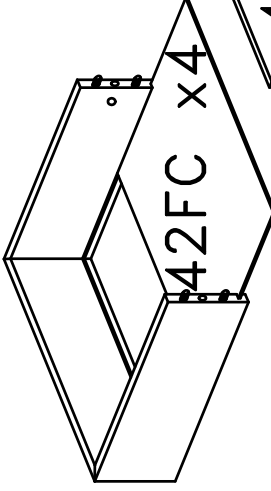

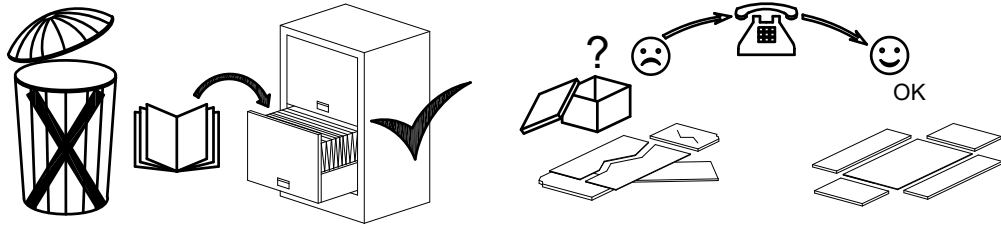
110TFAL x2

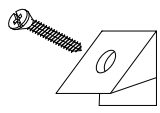

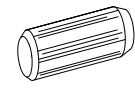
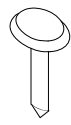
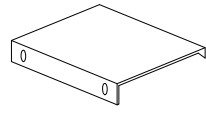
42SPON x4

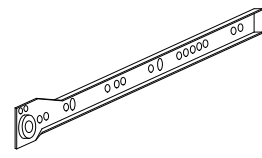
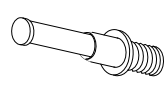
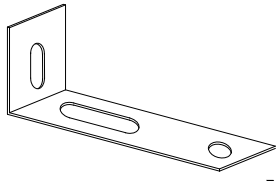
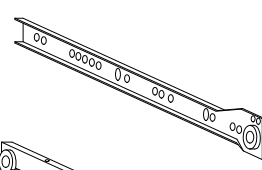
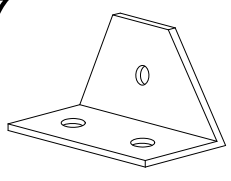

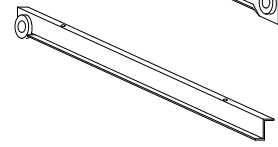

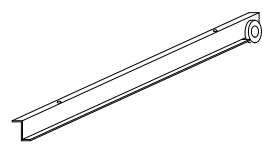
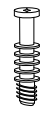
F  x16	L418  4x18 mm. x26	M2  3x16 mm. x8
B  8x30 mm. x24	CH  x4	S10  x4
C  ø15x12 mm. x8	P  x8	CL  x4
D  x8	PST  x1	CR  x4
P7  x8	E11  6x11 mm. x16	DR  x4
L3516  3.5x16 mm. x16	C1  ø12 mm. x8	DL  x4
	D1  x8	

1

B

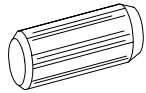

8x30 mm.

x8

P7

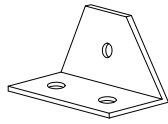

x4

L418



4x18 mm.

x8

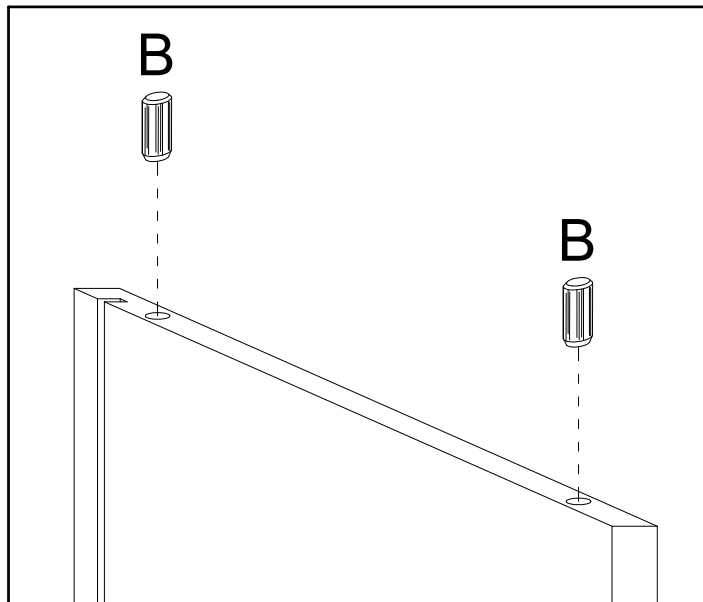
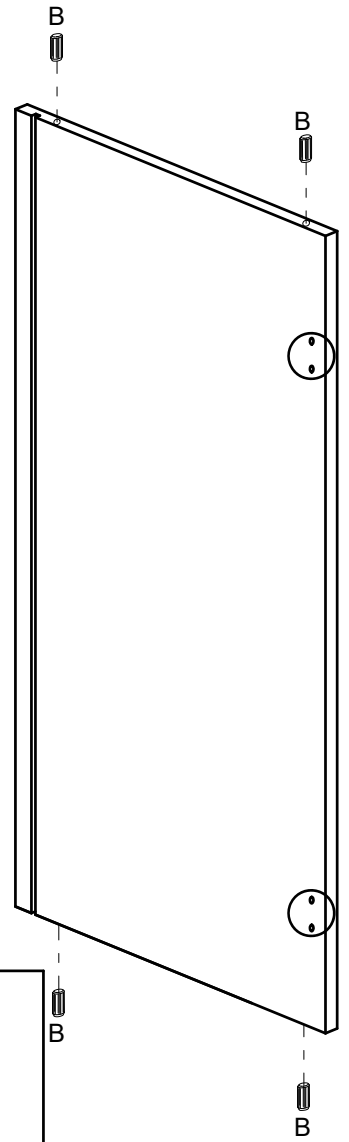
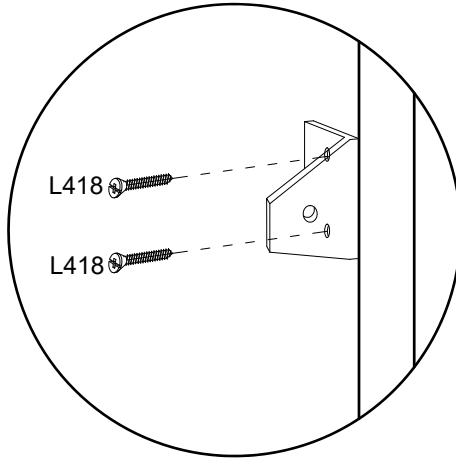
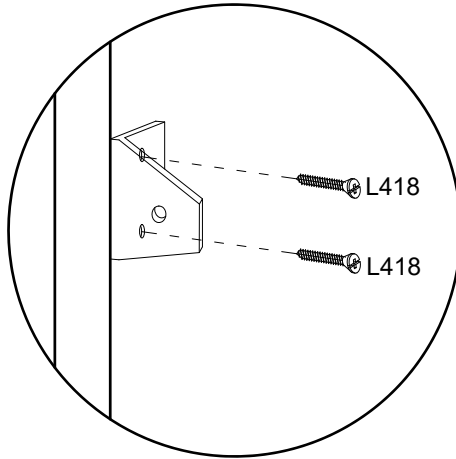
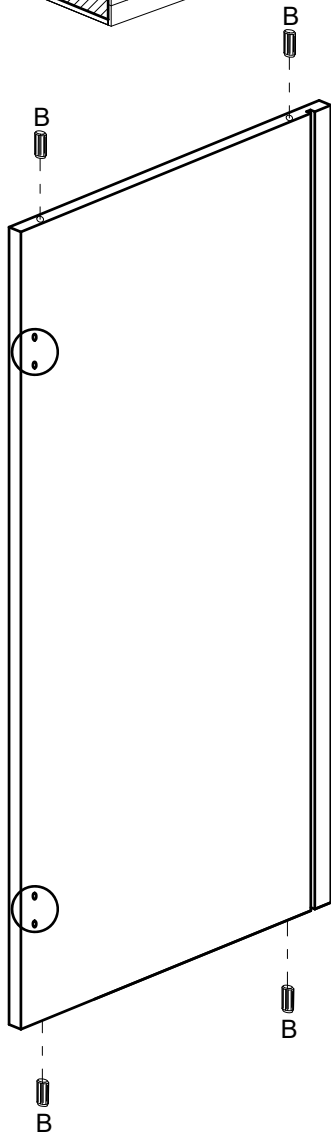
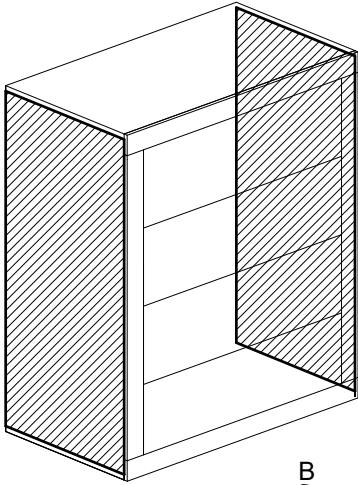

2

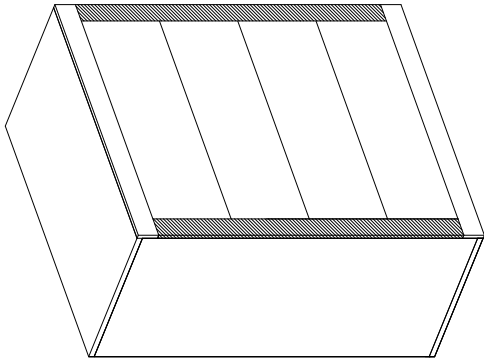

B

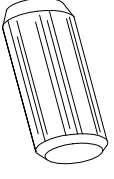

X8

8x30 mm.

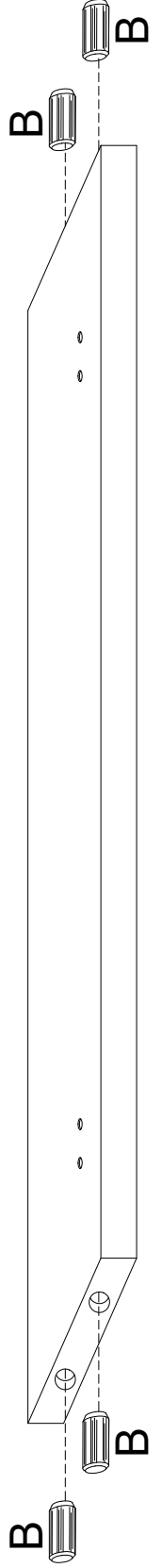
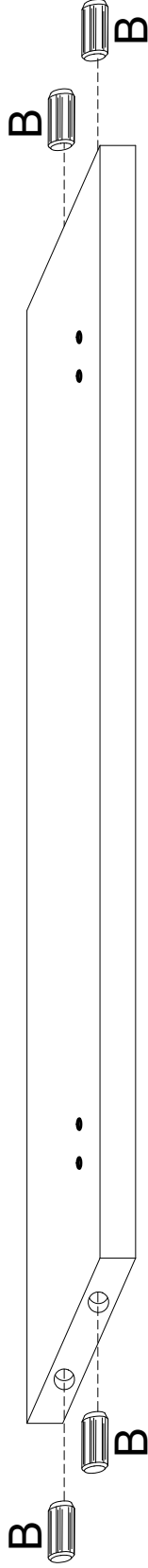

3

L418



4x18 mm.

x4

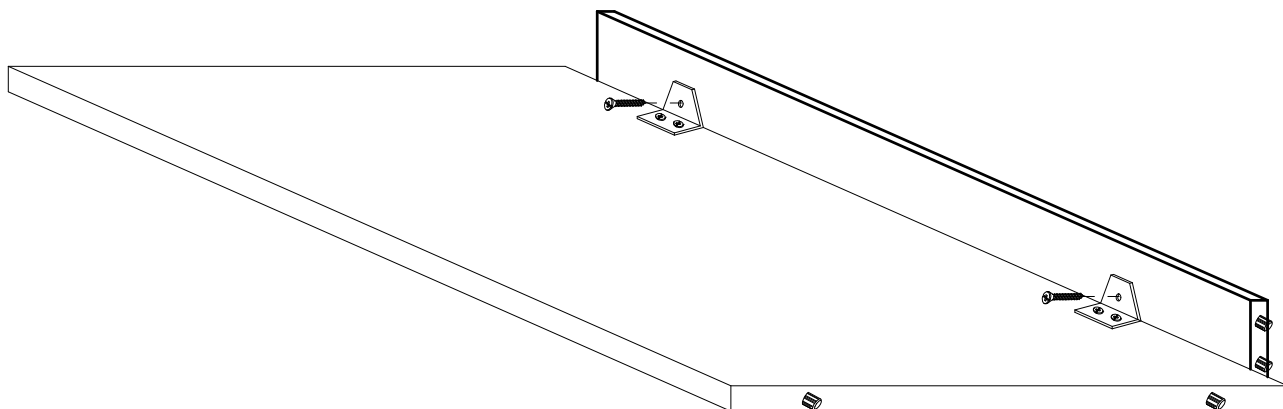
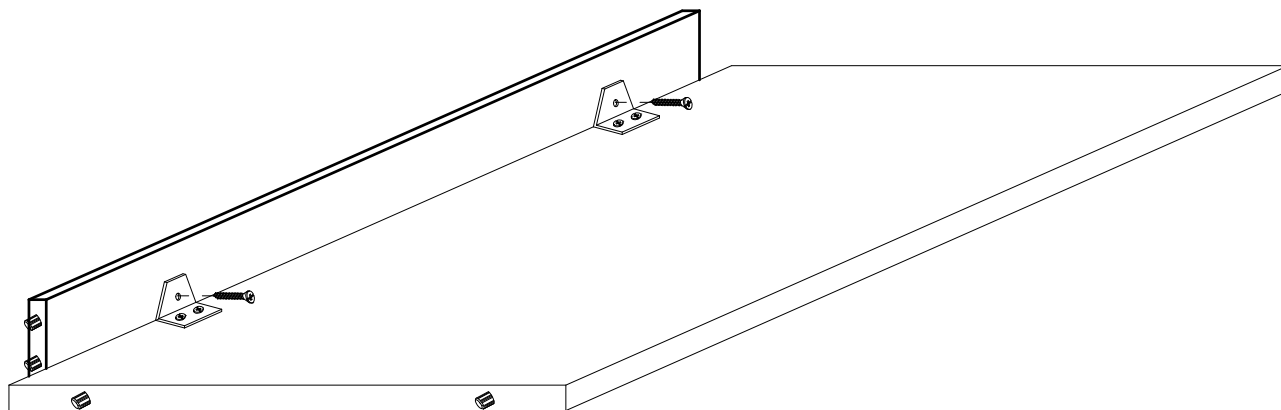
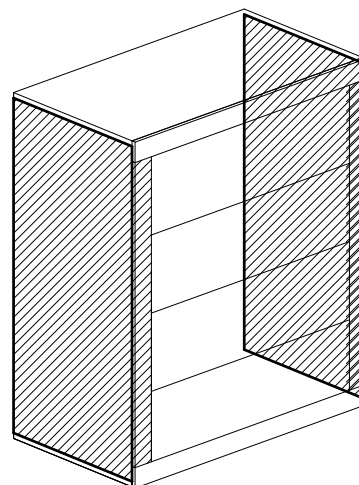
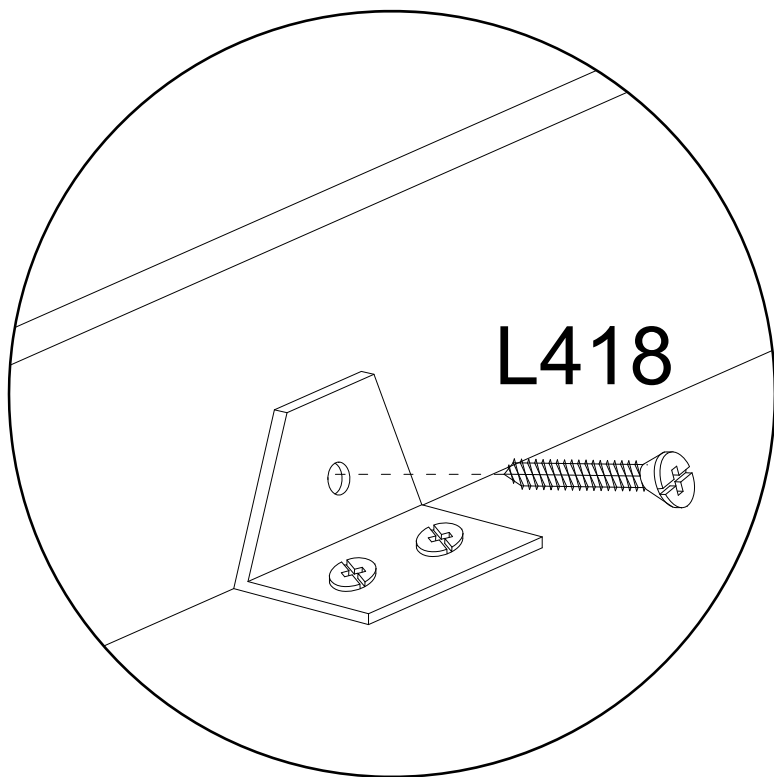

4

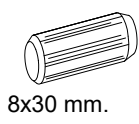
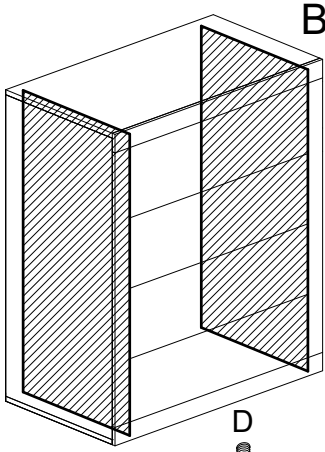

8x30 mm. x8

D

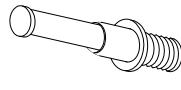

x8

CL

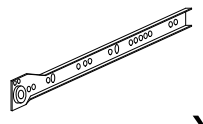

x4

CR

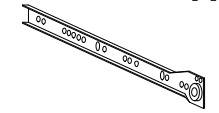

x4

E11



6x11 mm.

x16

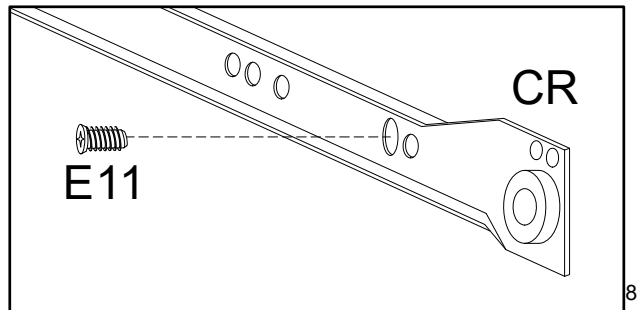
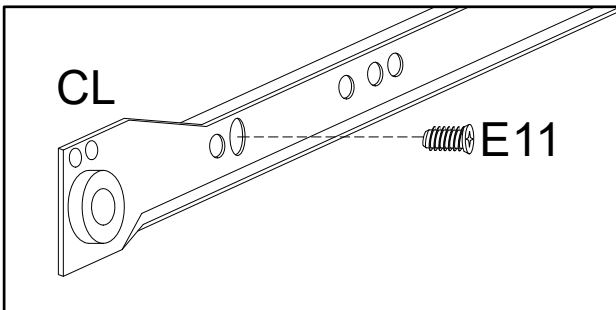
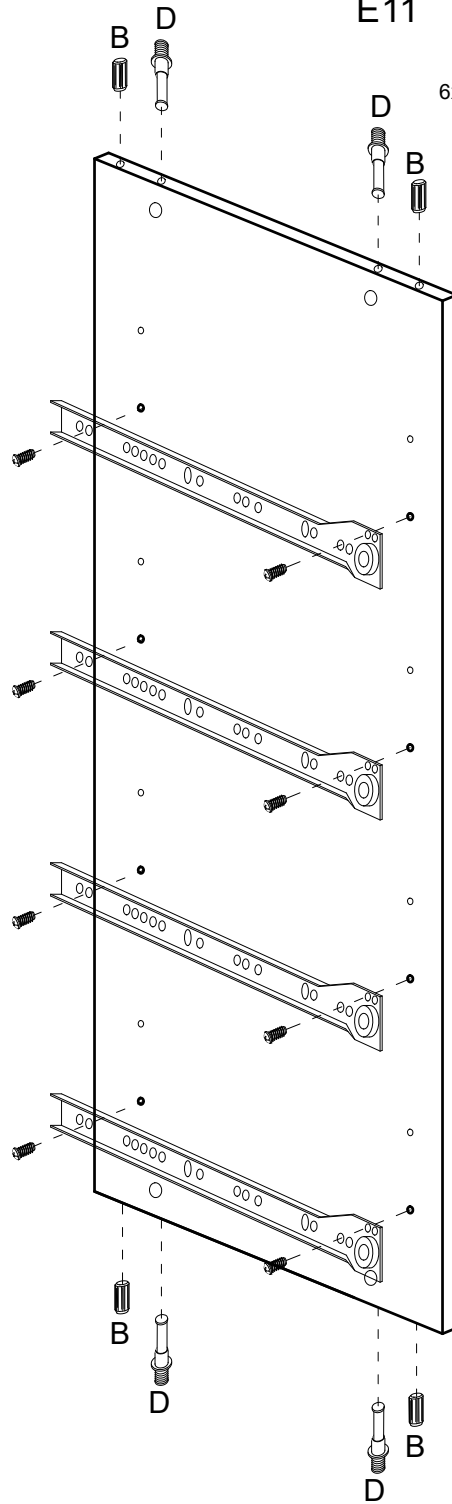
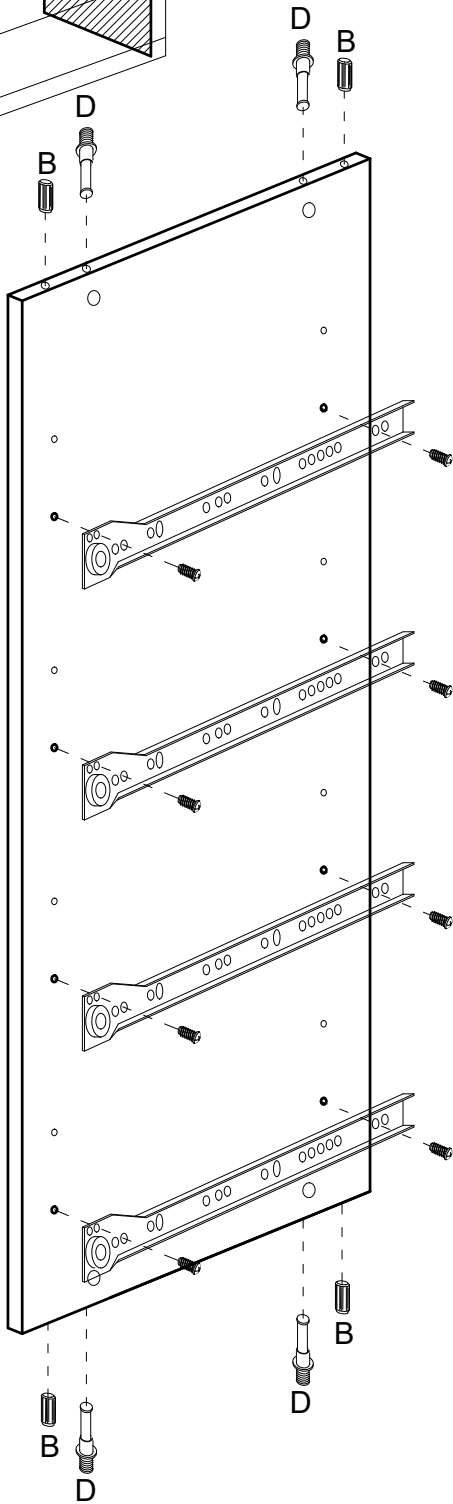

5

L418

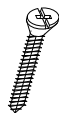

4x18 mm.

X8

P7

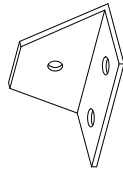

X4

CH

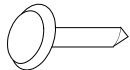

X4

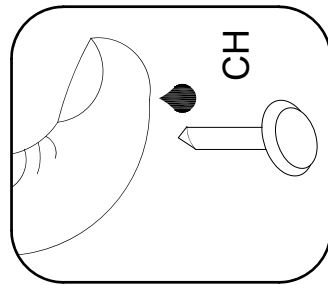
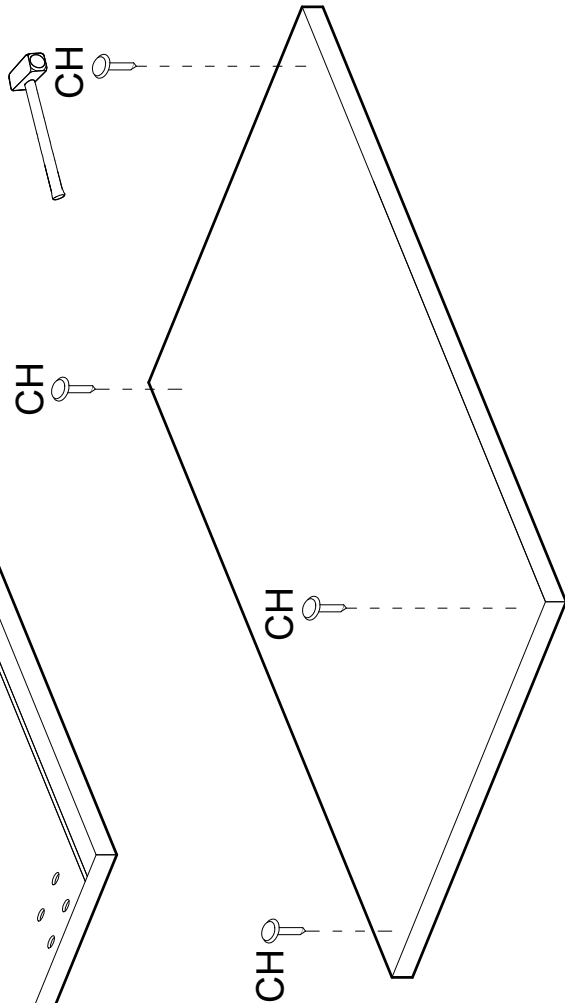
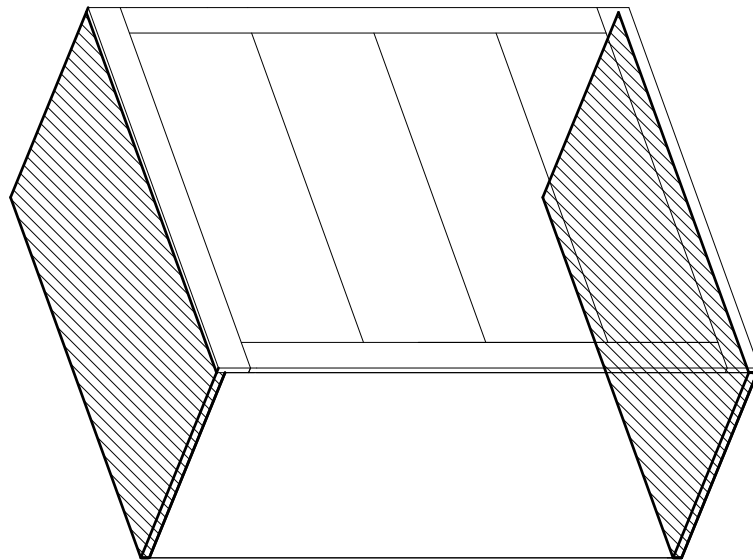
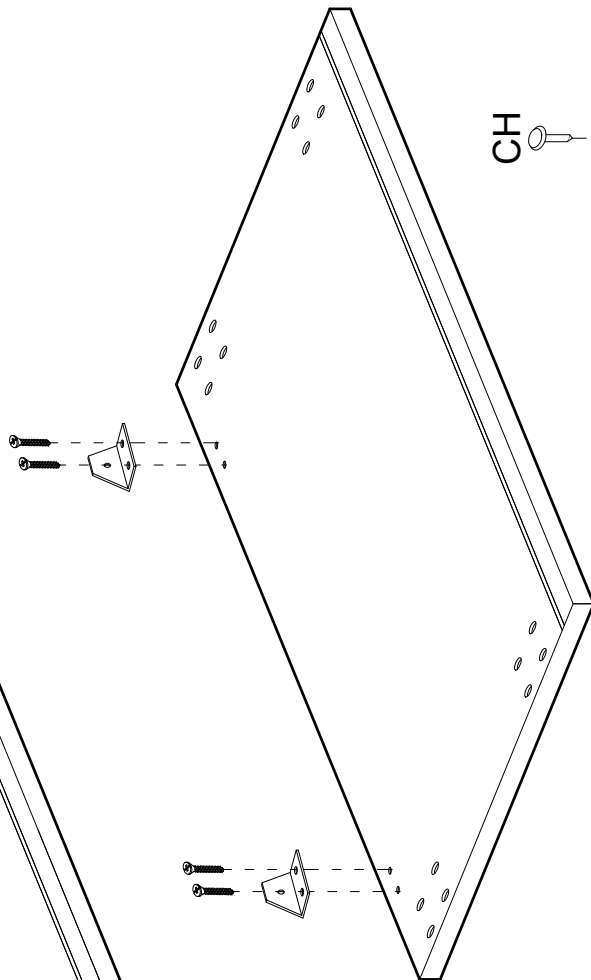
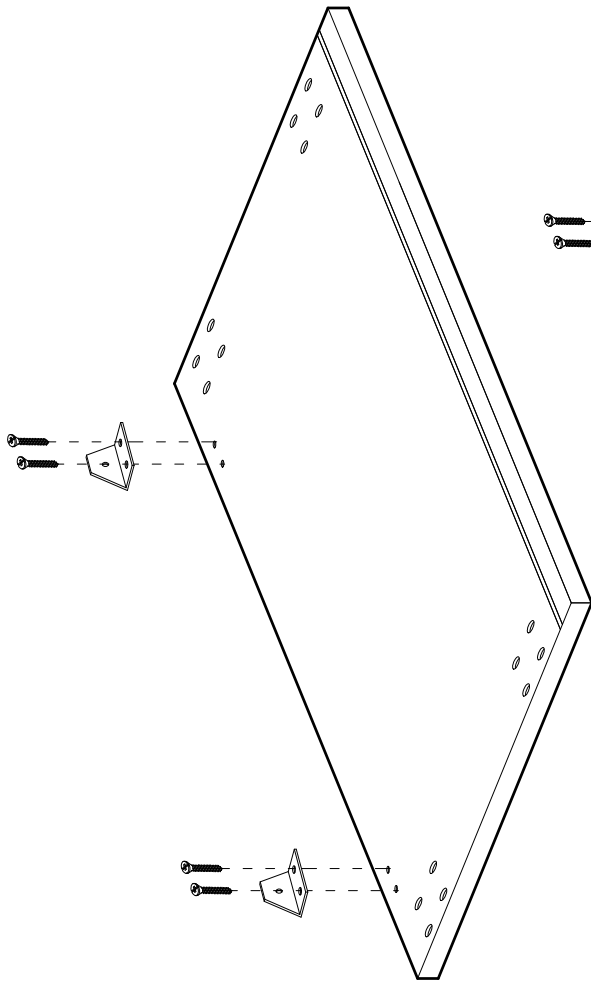

6

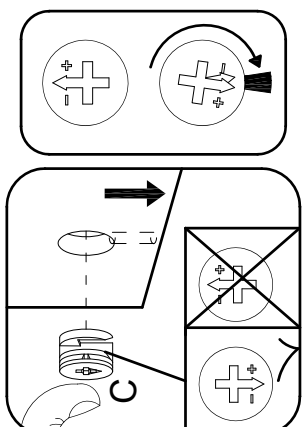

C

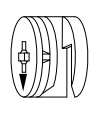

ø15x12 mm. X4

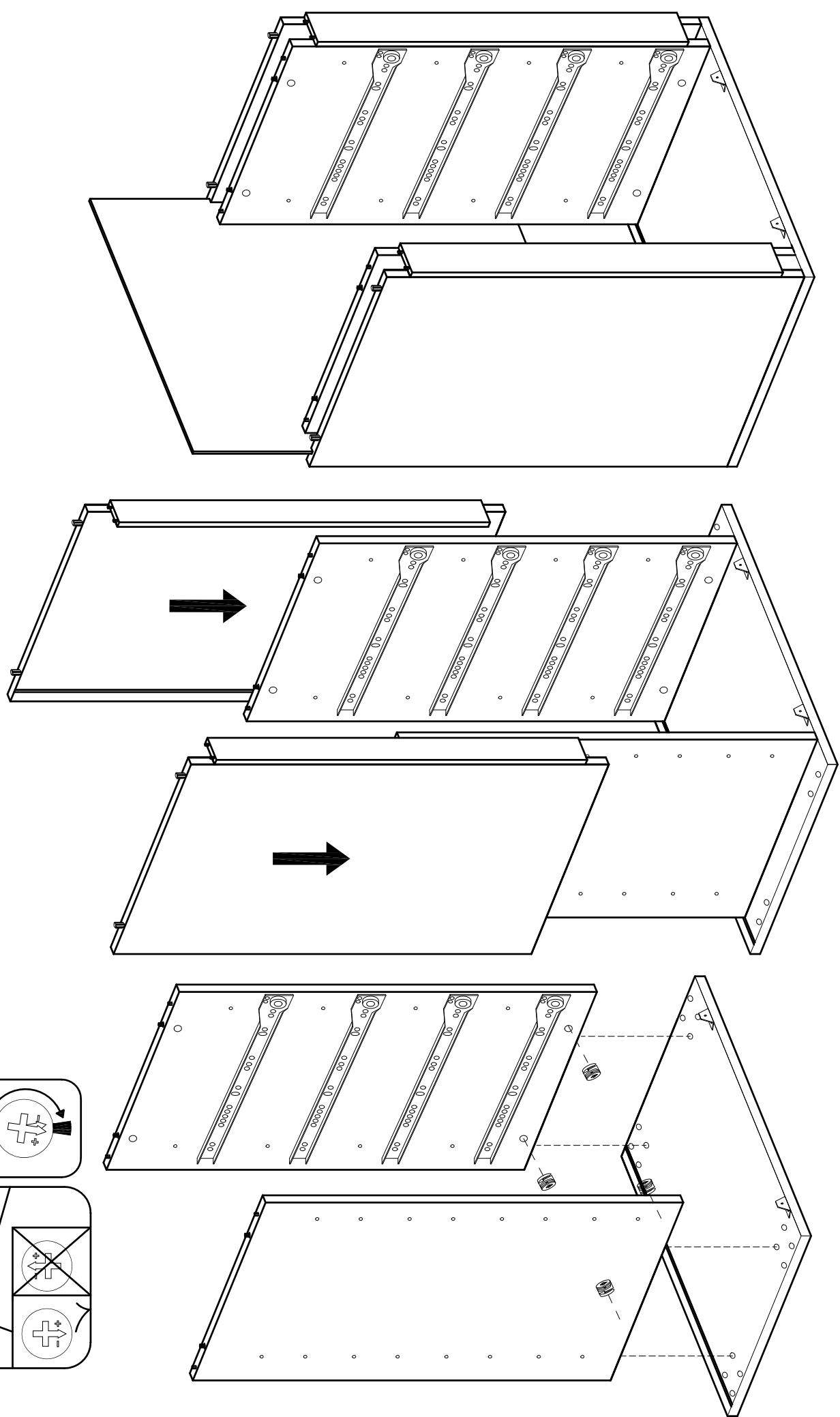

7

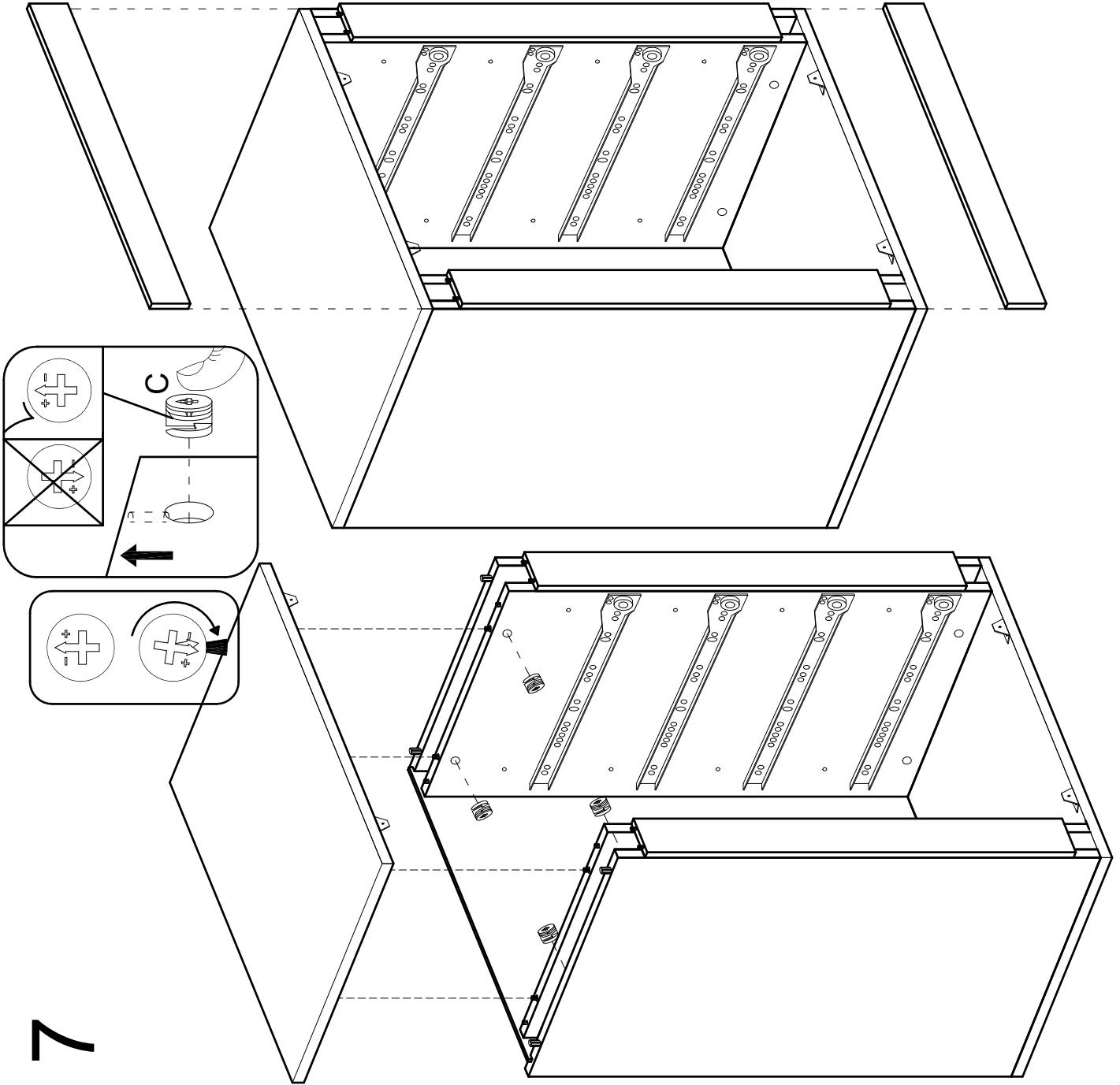
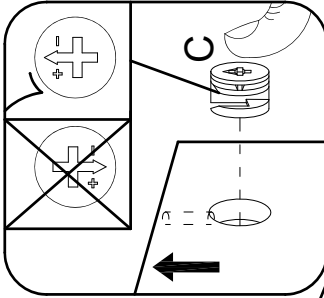
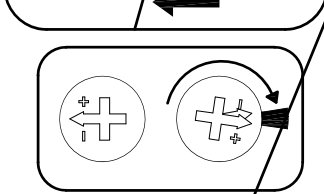

C

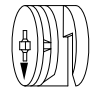

ø15x12 mm. X4

L418

4x18 mm. X4

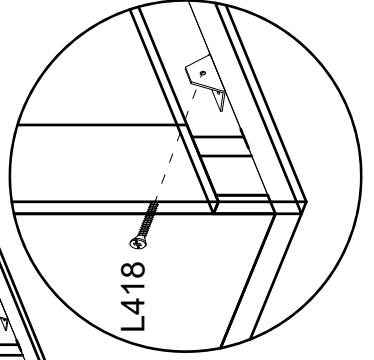
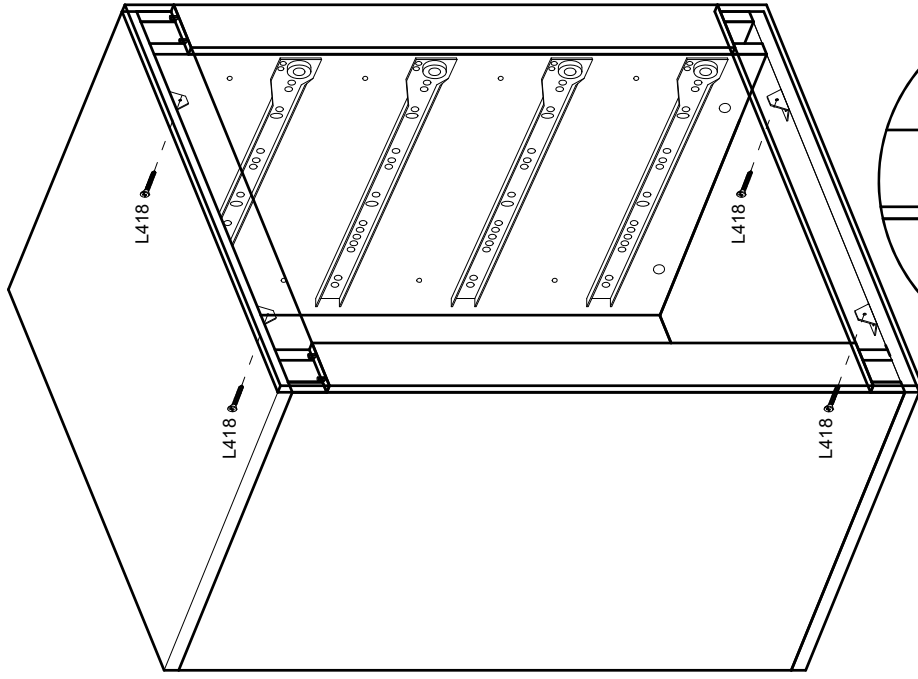

F

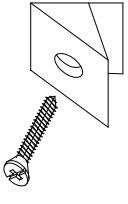

X8

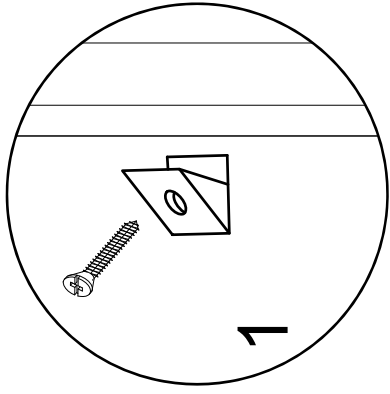
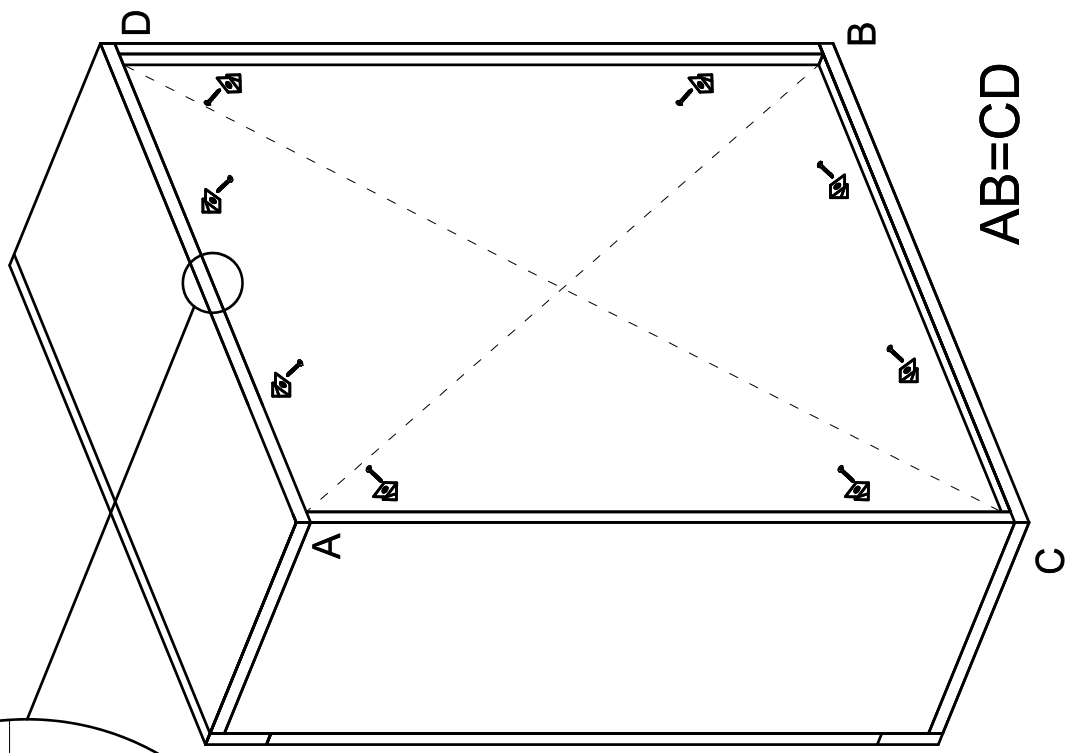
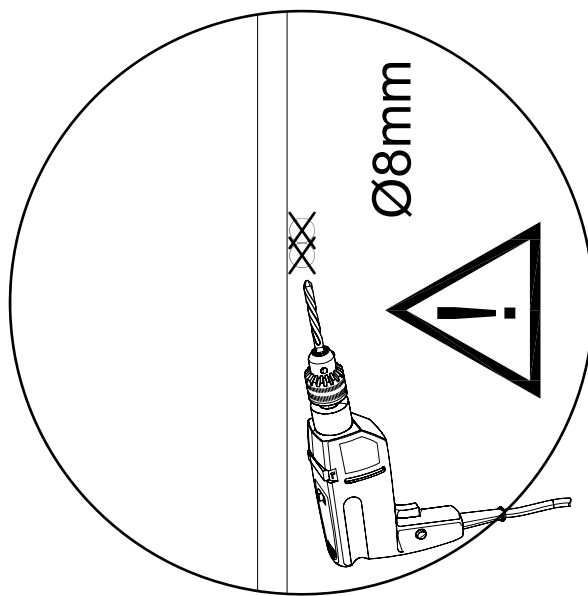
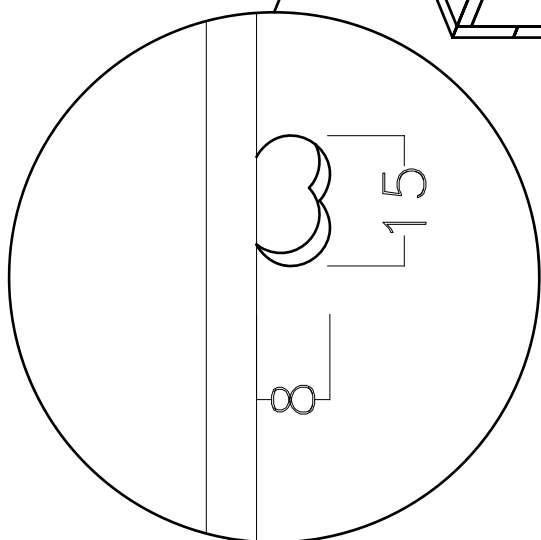

1

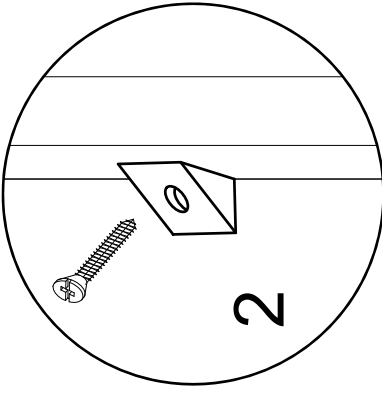

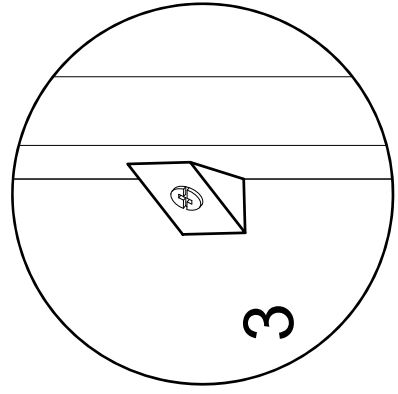

2

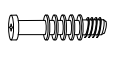
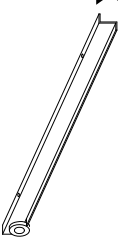
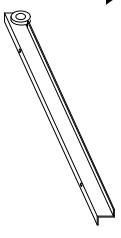
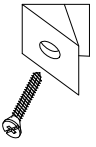
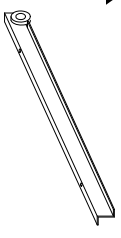
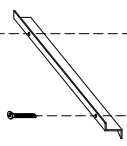

3

9

- C1  $\phi 12$ mm. X8
- D1  X8
- DR  X4
- DL  X4
- F  X8
- L3516  X4
- L316  X8
- P  X8

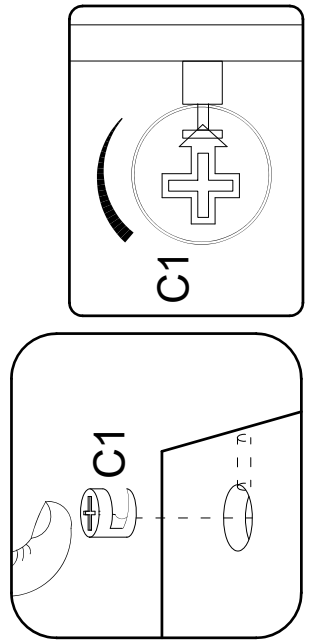
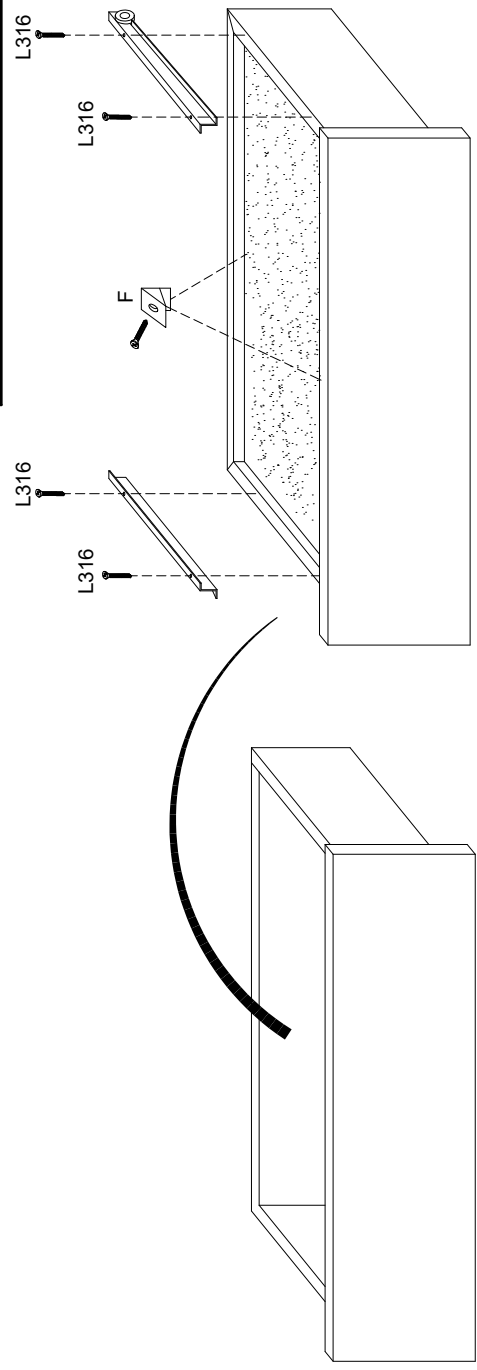
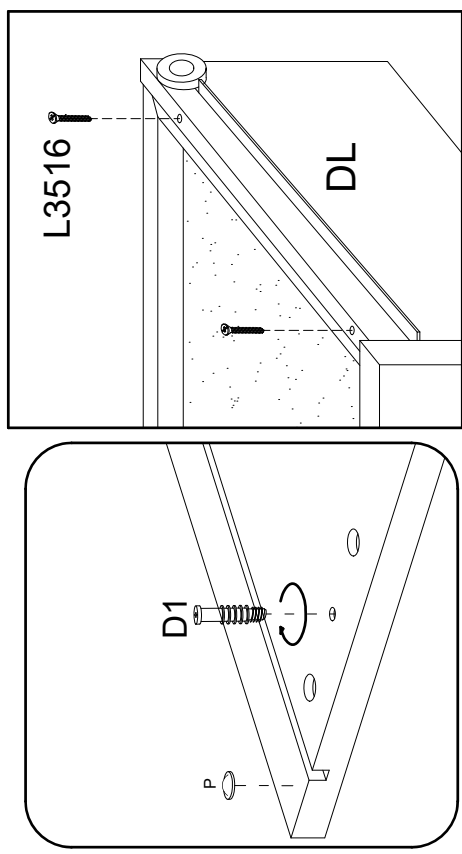
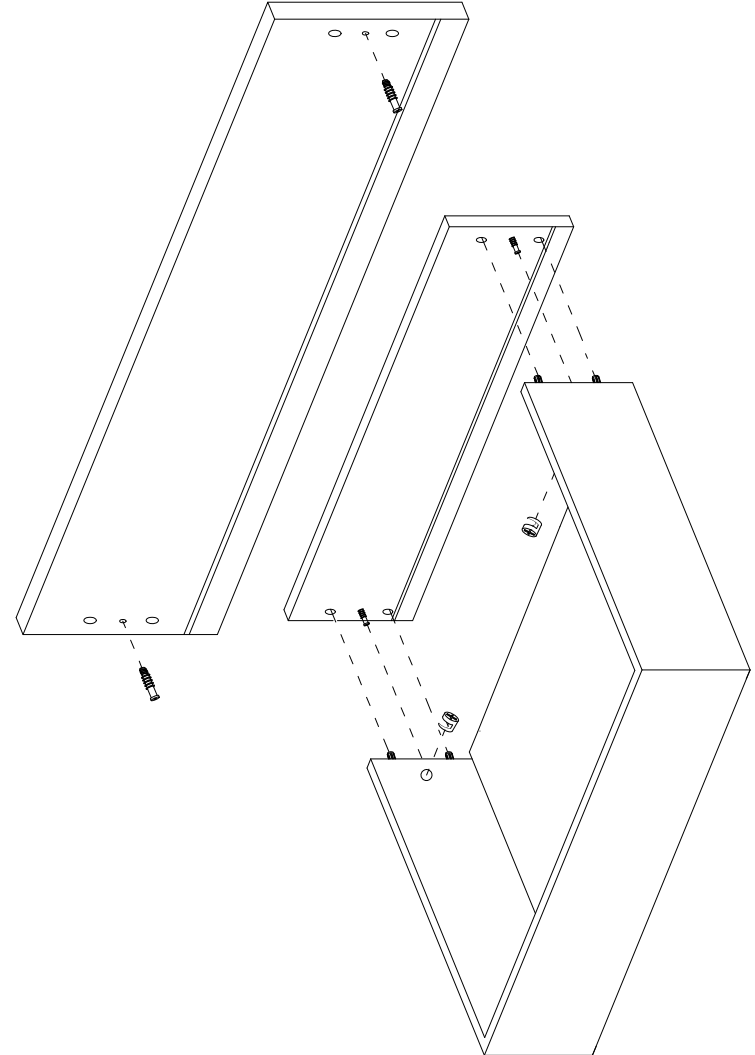

10

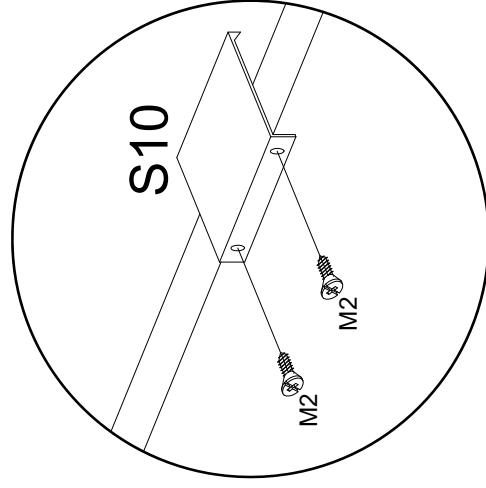
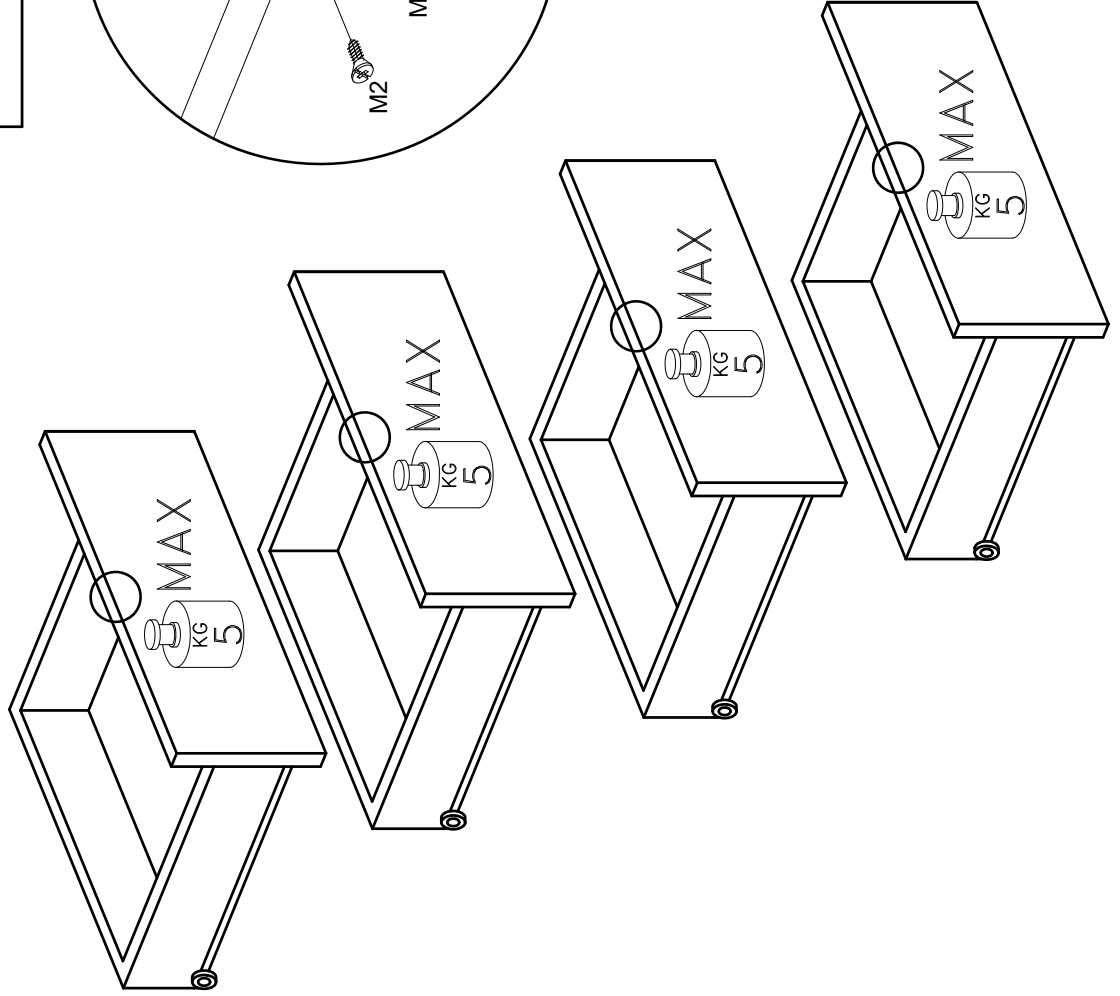
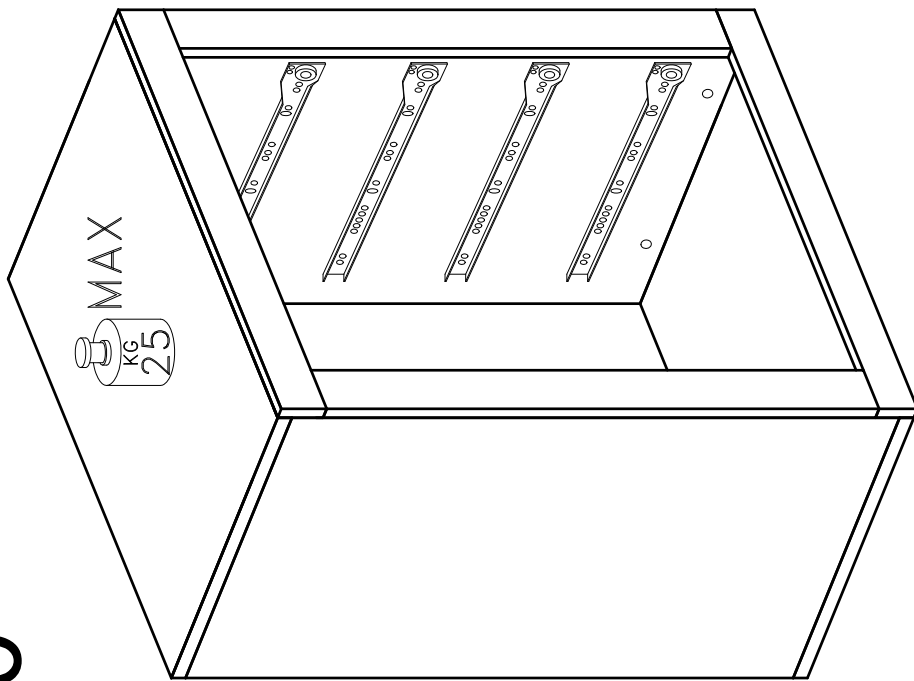

M2



3x16 mm.

x8

S10

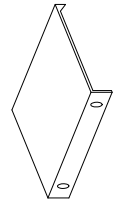

x4

11

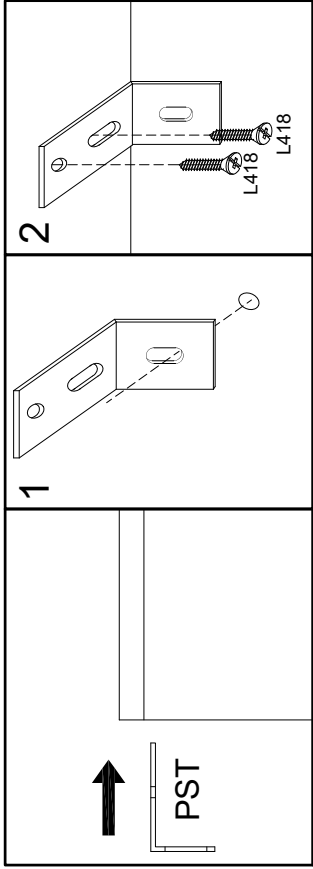

Cher client,
l'installation des meubles suspendus doit être effectuée par un personnel compétent.

Les fishers ne sont pas inclus dans la quincaillerie.

Choisir les types des fishers pour le fixage apte au mur.

S'assurer de l'adéquation du mur pour support sûr du meuble

Dear Customer

The assembling of the hanging elements must be done by a competent staff.

The fishers are not included in the hardware package.

Choose the fisher more suitable to the type of the wall.

Ensure the suitability of the wall for a secure support of the hanging element.

Sehr geehrter Kunde, die Montage der Haengeelemente muss von Fachpersonal ausgefuehrt werden! Bitte verwenden Sie eigene, der Beschaffenheit der Wand entsprechende Duebel. Zu Ihrer eigenen Sicherheit legen wir dem Beschlagbeutel keine Fischerduebel bei.

Gentile Cliente

Il montaggio dei pensili deve essere effettuato da personale competente.

I tasselli di fissaggio non sono compresi nella ferramenta.

Scegliere il tipo di tassello per il fissaggio più adatto alla tipologia di muro.

Assicurarsi l'idoneità della parete per un sostegno sicuro del pensile.

el.42

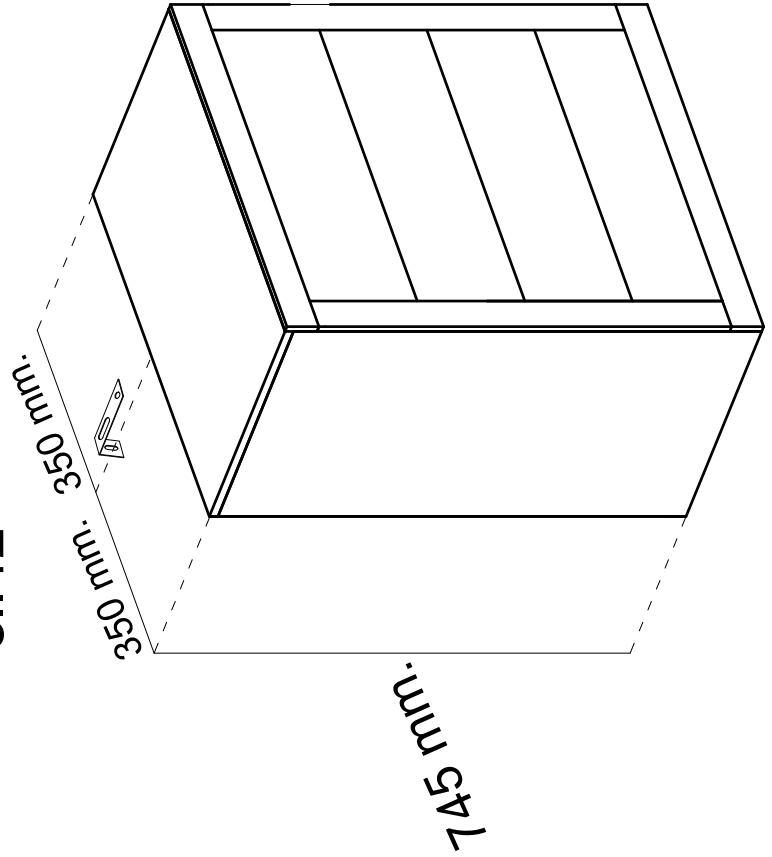

el.41

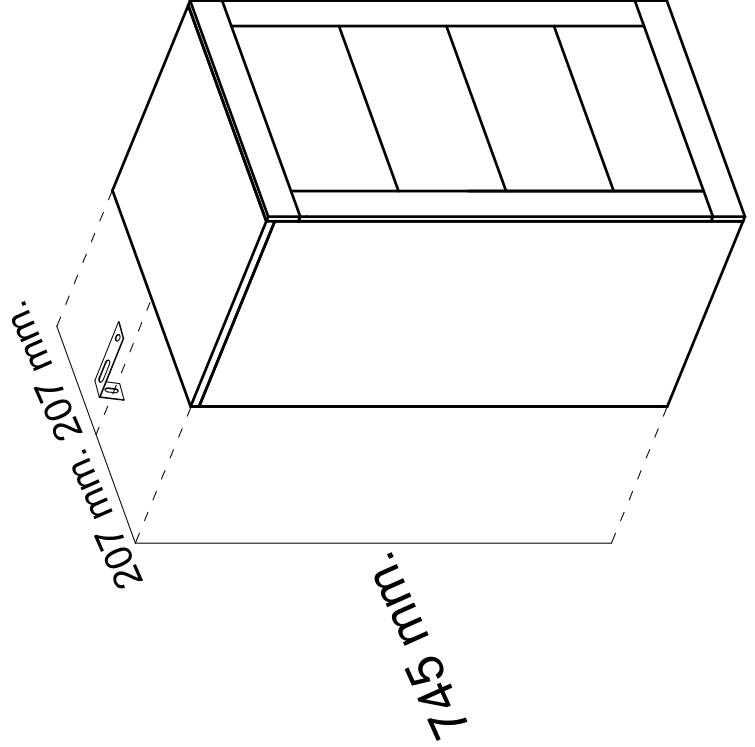

4x18 mm.

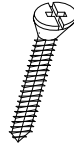

L418 x2

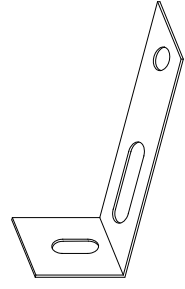

PST x1