

SENSO

SK> NÁVOD K MONTÁŽI
CZ> NÁVOD K MONTÁŽI
PL> INSTRUKCJA MONTAŻU
D> MONTAGEANLEITUNG
GB> ASSEMBLY INSTRUCTIONS
F> MODEL D'EMPLOI
HU> SZERELÉSI ÚTMUTATÓ



Užitečné rady predtým, ako začnete:

1. Odporúčame vám, aby ste si na chvíľu našli čas na prečítanie tohto letáku a potom postupovali podľa inštrukcií krok za krokom.
2. Ak budete postupovať podľa inštrukcií, konečný výsledok bude stáť za úsilie.
3. Nevyhadzujte žiadne obaly, kým sa neujistíte, že máte všetky časti a všetky kovania.
4. Montáž produktu by mala prebiehať na koberci.
5. Aby ste zabezpečili ľahšiu montáž, dôrazne odporúčame, aby všetky montážne prvky boli na začiatku pritiahnuté len mierne. Po dokončení montáže je potrebné prvky dotiahnuť čo najviac (s citom).
6. Odporúčame pravidelnú kontrolu všetkých montážnych bodov. Uistite sa, že sú plne pritiahnuté.
7. Drobné diely držte mimo dosahu detí.
8. Nepoužívajte iné nástroje, než sú odporúčané.
9. Prosíme, nepoužívajte náhradné diely. Používajte iba doplnkové alebo náhradné diely dodané výrobcom.
10. Pravidelne kontrolujte všetky skrutky a skrutky, aby ste sa uistili, že sa neuvolnili.
11. Zásuvky v posteliach sú určené na ukladanie ľahkých predmetov, ako sú vankúše, prikrývky a posteľná bielizeň. Snažte sa vyhnúť ukladaniu ťažších predmetov, ako sú knihy alebo hračky.

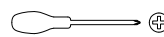

Budete potrebovať krížový skrutkovač.

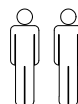

Na montáž postieľky sú potrebné 2 osoby.



Približný čas montáže produktu.

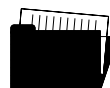

Uchovajte tento návod na budúce použitie.



Nezahadzujte obaly, kým neoveríte, že máte všetky časti a kovania.

Helpful advise before you begin:

1. We suggest you spend a short time reading through this leaflet and then follow the simple step by step instructions.
2. If you follow the instructions carefully the end result should be worth the effort.
3. Do not discard any of the packaging until you have checked that you have all the parts and the pack of fittings
4. Assemble this product on a carpet.
5. To ensure an easier assembly, we strongly advise that all fittings are only finger tightened during initial assembly. Only upon completion of the assembly should all fixing points be fully tightened.
6. We recommend a periodic check on all fixing points to make sure they remain fully tightened.
7. Keep glue and fittings out of children's reach.
8. Do not use any other tools other than those recommended to build this product.
9. Please do not use substitute parts. Use only additional or replacement parts supplied by supplier
10. Check all bolts, screws and legs regularly to make sure they haven't loosened and tighten all joints of your furniture or bedstead after 6 months.
11. Storage Drawers in Bedsteads are designed to carry lightweight items such as Pillows, duvets and linen. Please try to avoid storing heavier items such as books or toys.

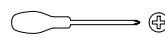

You will require a cross head screwdriver

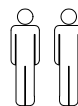

2 x people recommended to assemble this product



Approximate time to assemble this product

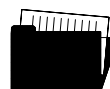

Retain these instructions for future reference



Do not discard any of the packaging until you have checked that you have all the parts and the pack of fixings.

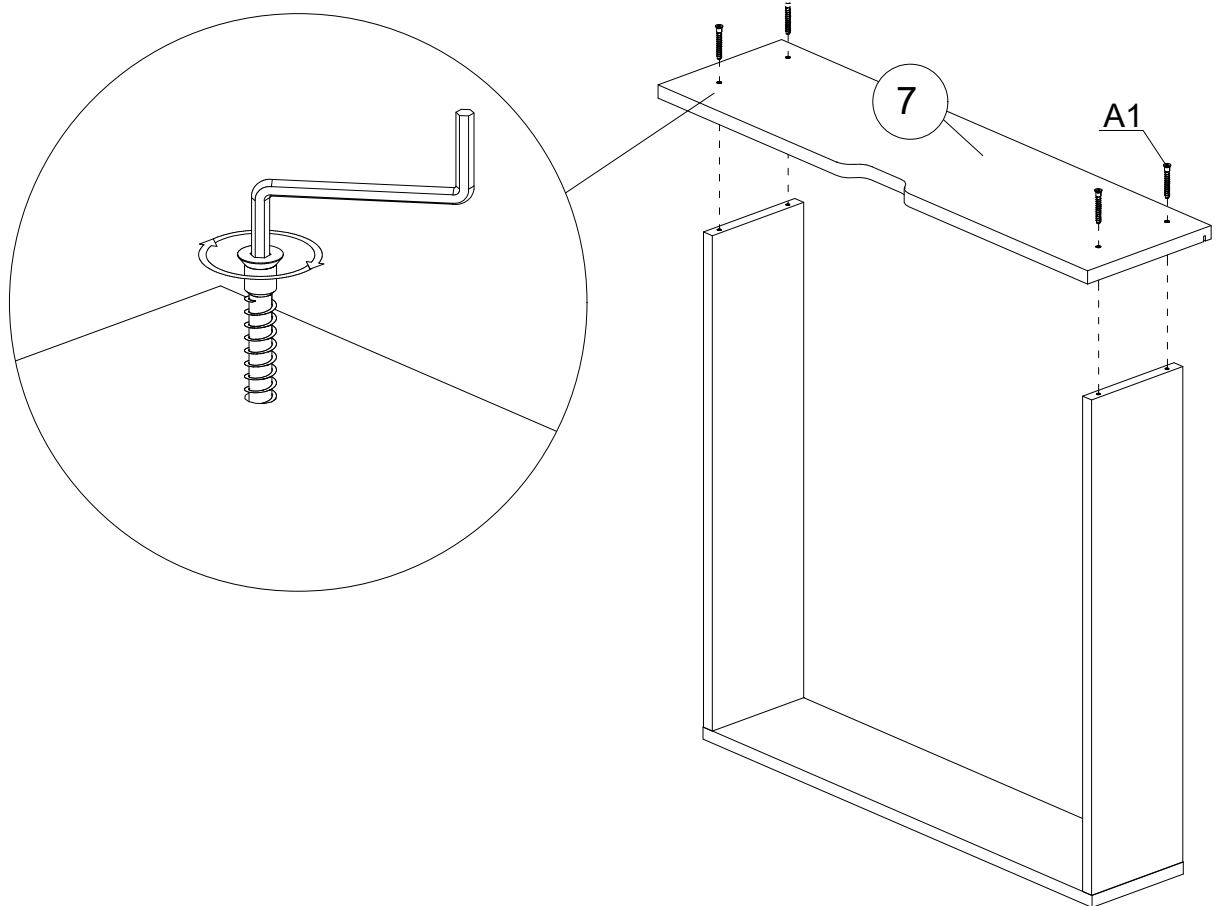
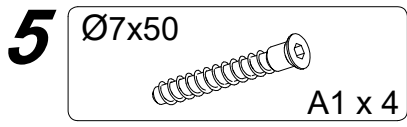
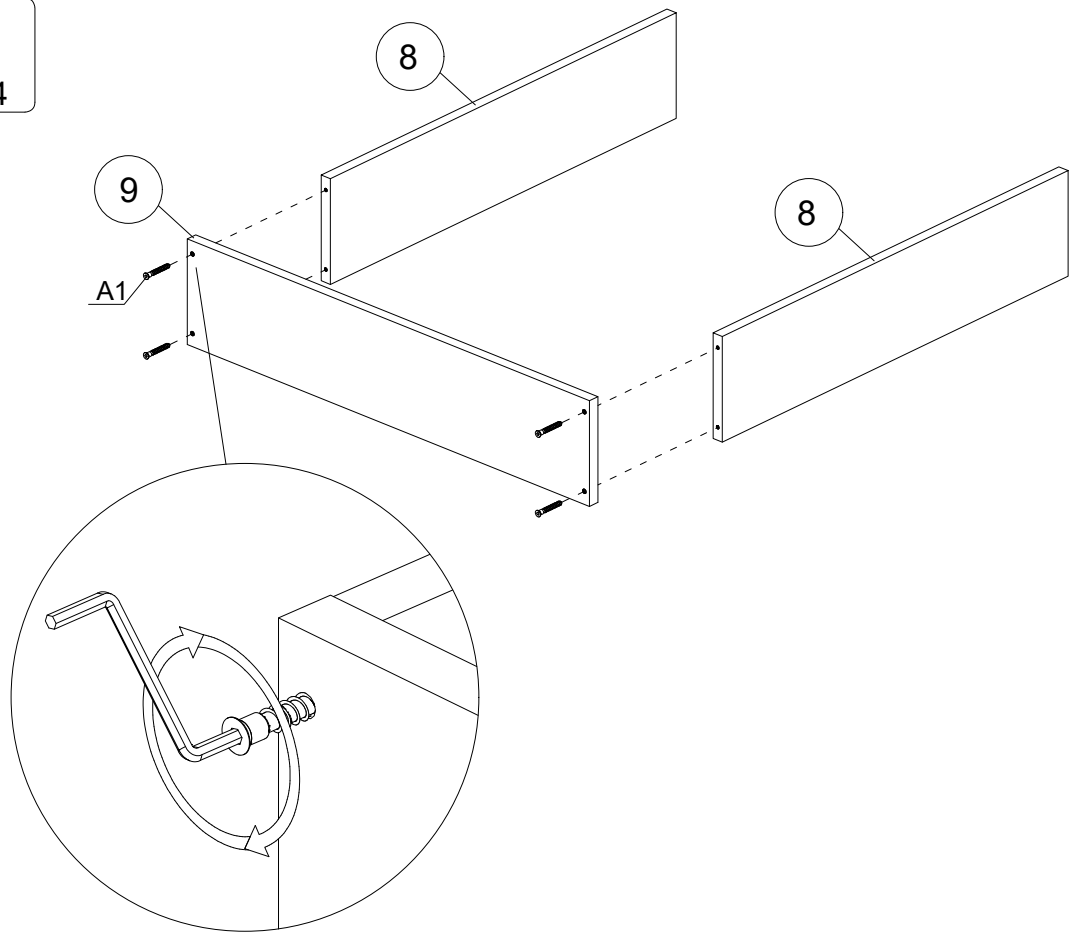
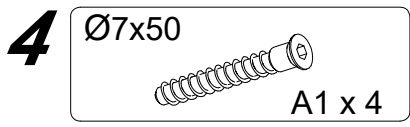

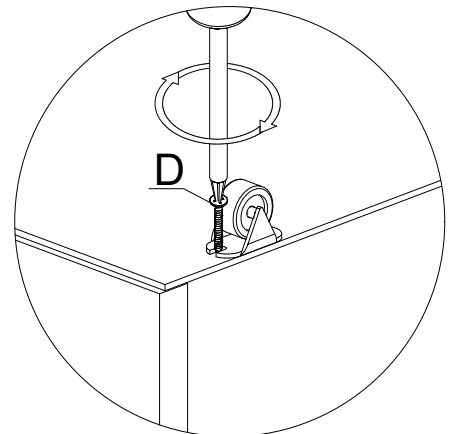
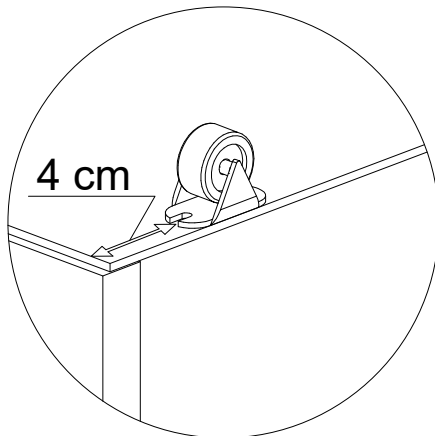
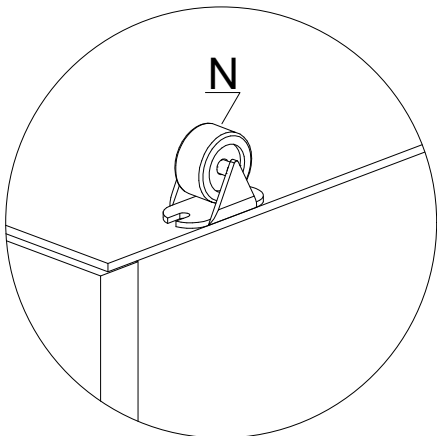
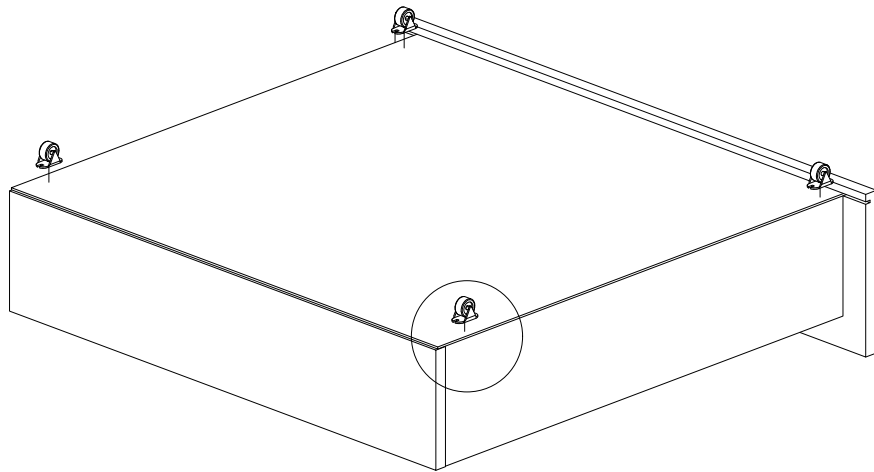
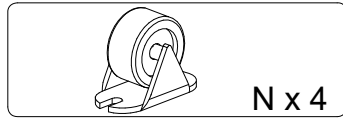
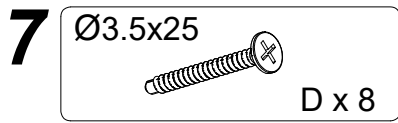
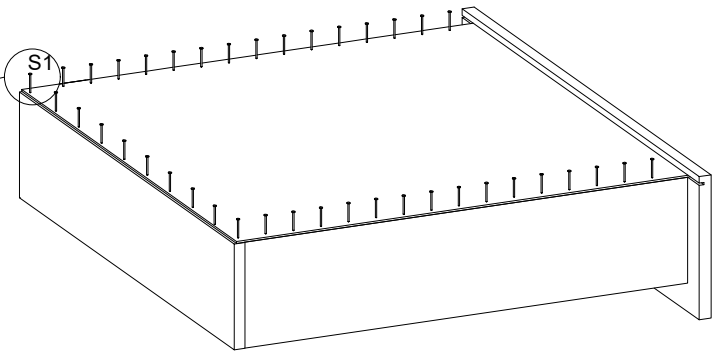
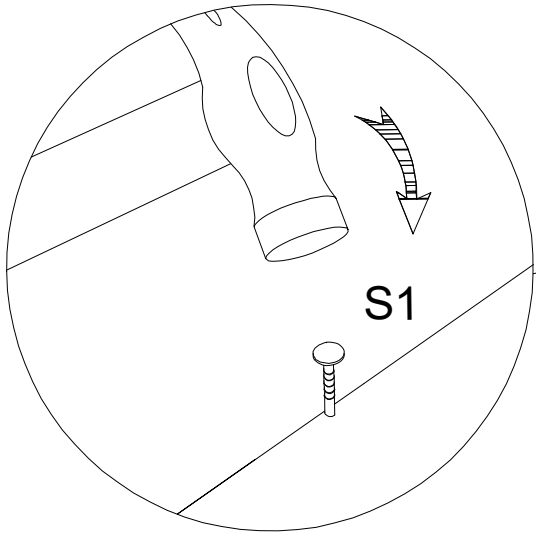
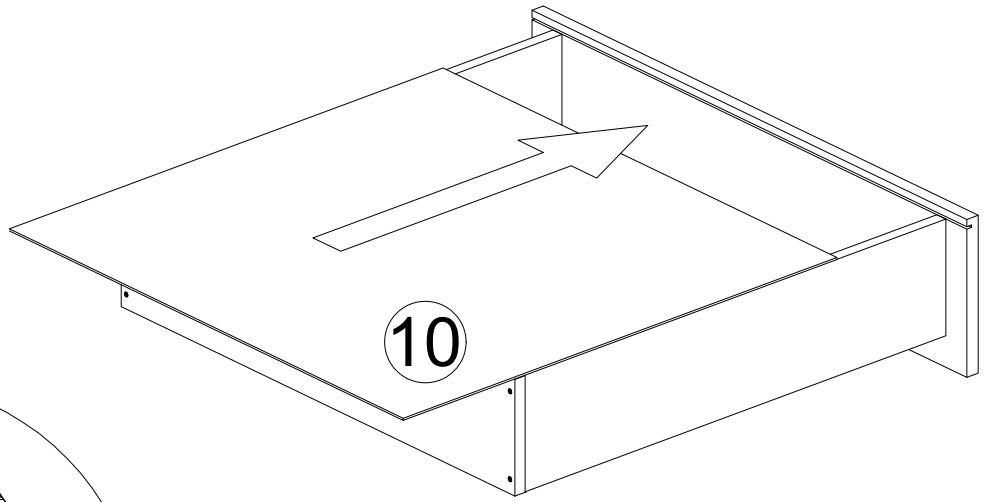
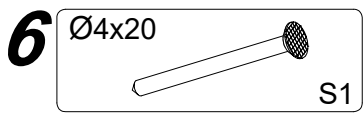

8

Ø7x70

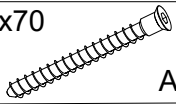

A x 4



Q x 1

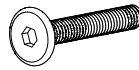

R x 1

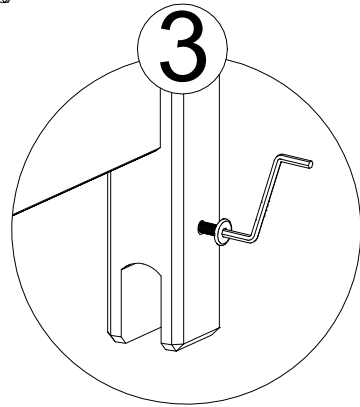
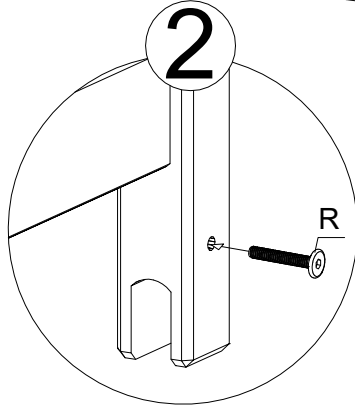
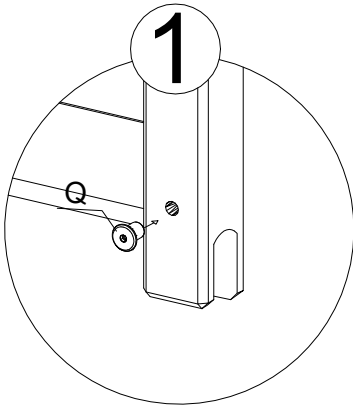
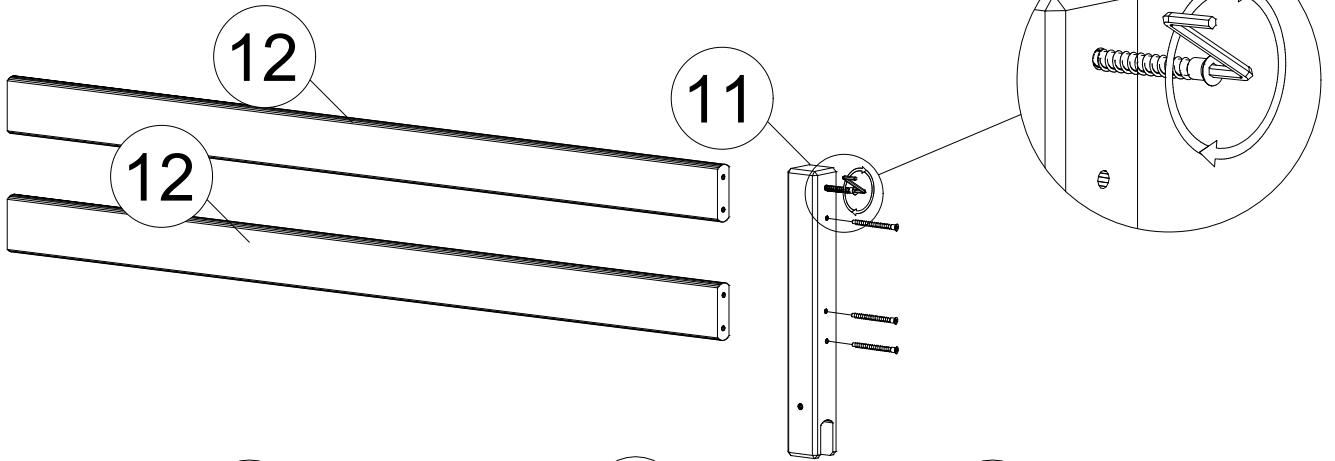
**9**

?

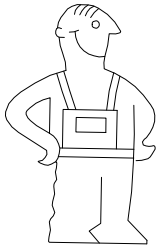

L

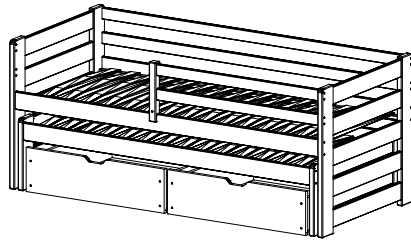

P

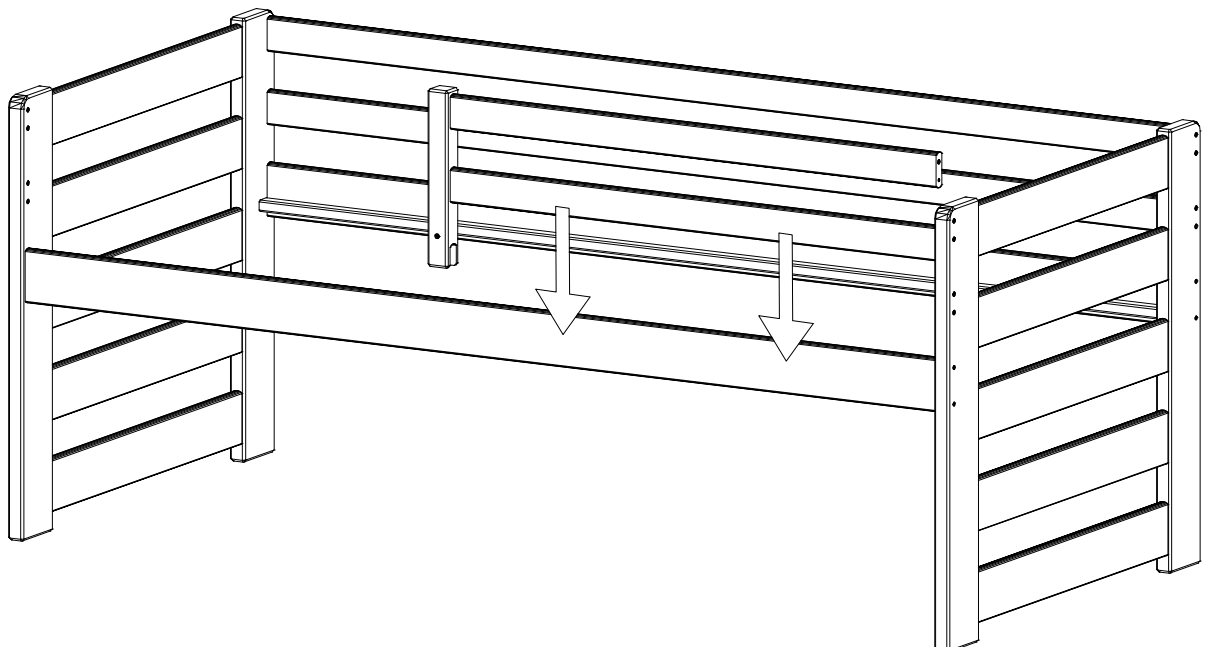
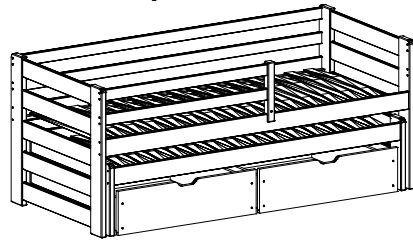

10

Ø7x70

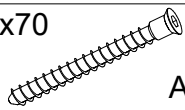

A x 4

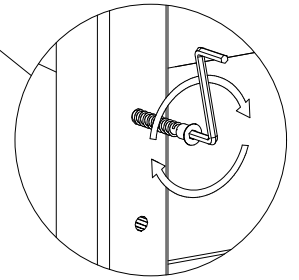
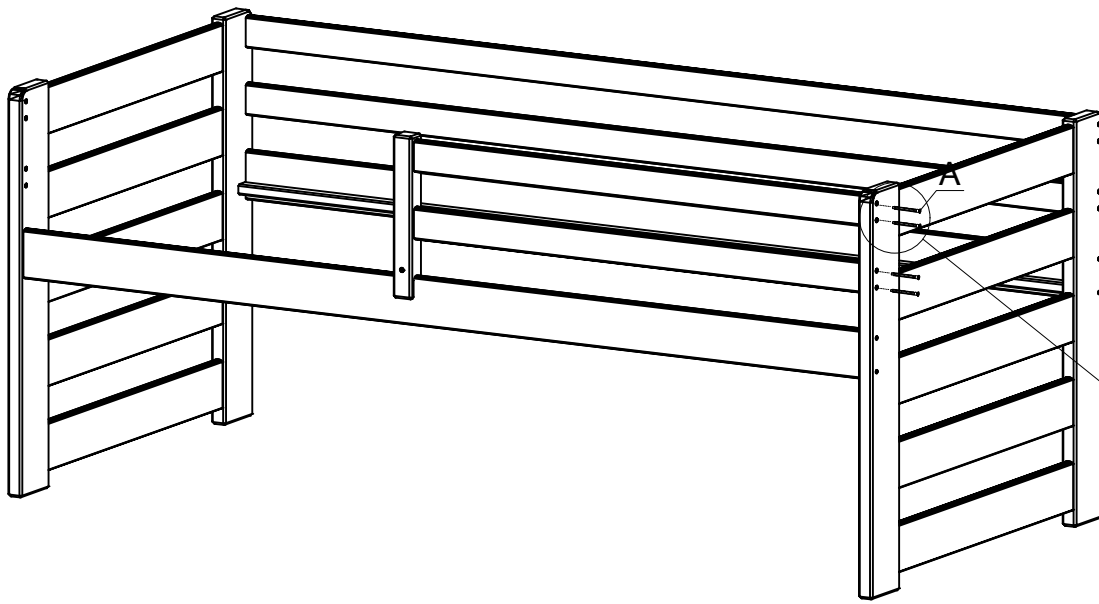

11



N1 x 2

Ø3.5x25



D x 4

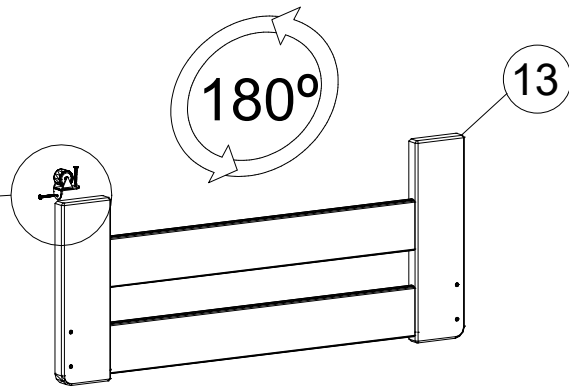
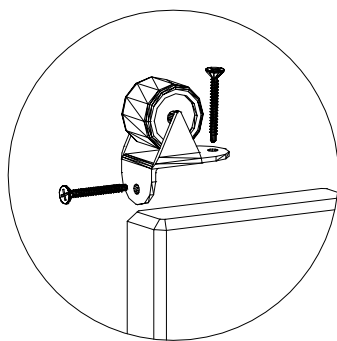

12

Ø3.5x40

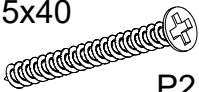

P2 x 16

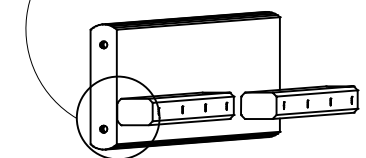
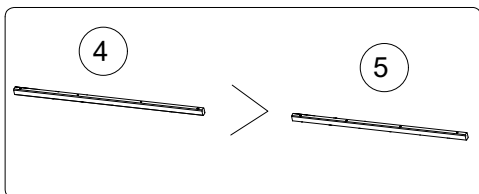
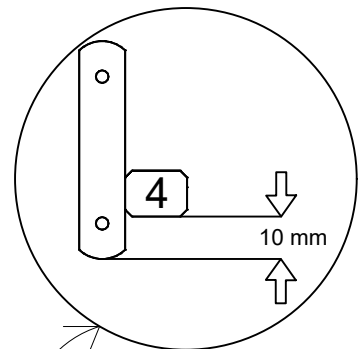
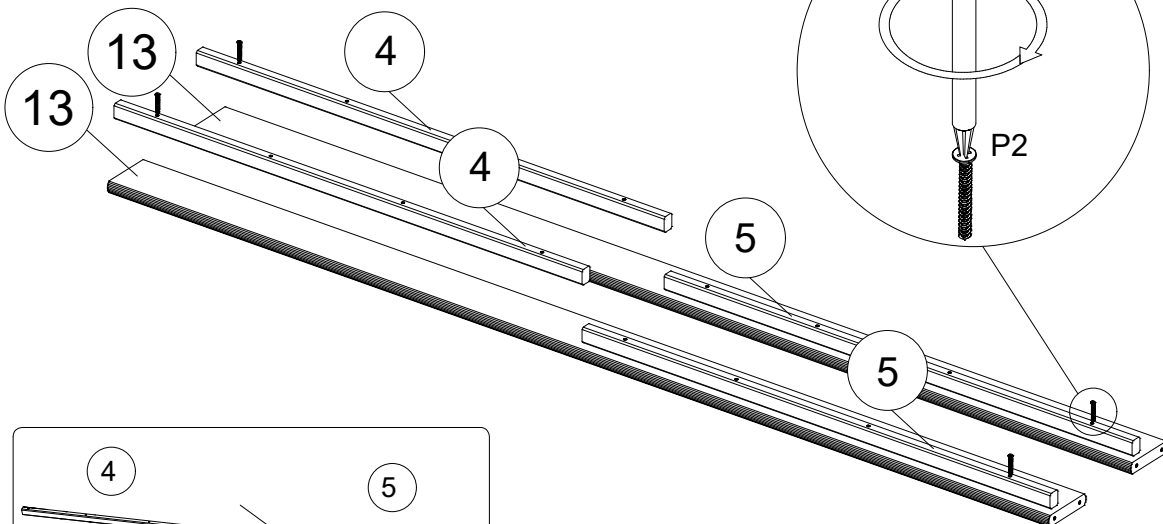

13 Ø7x70
A x 8

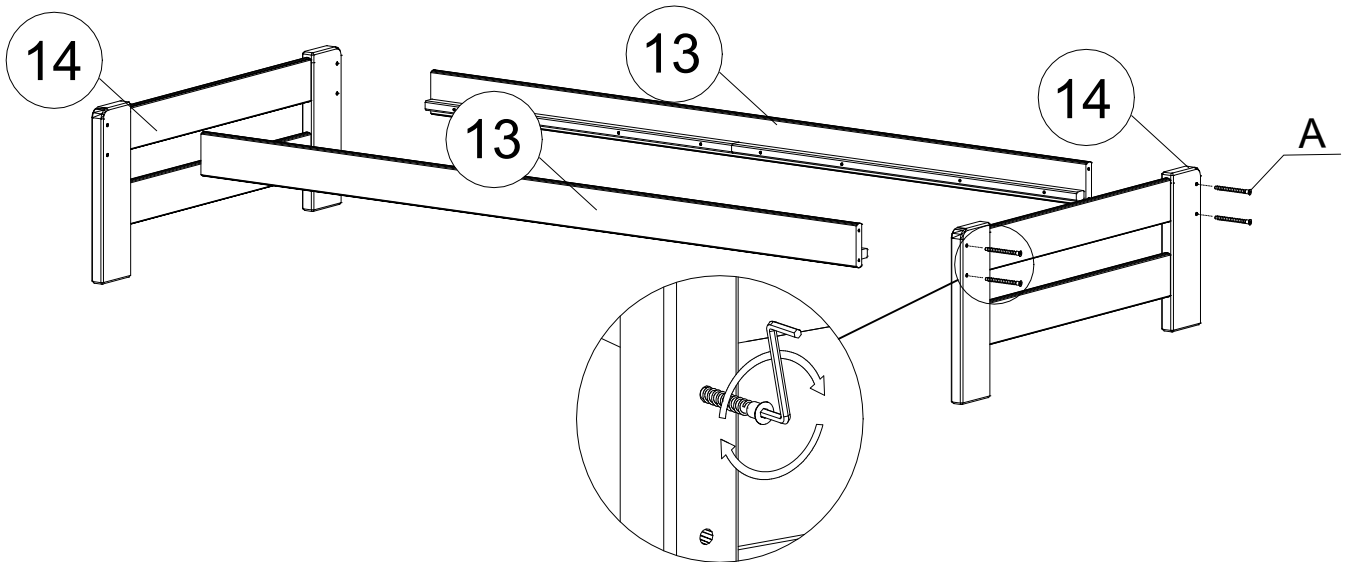

14 Ø3.5x25
D x 12

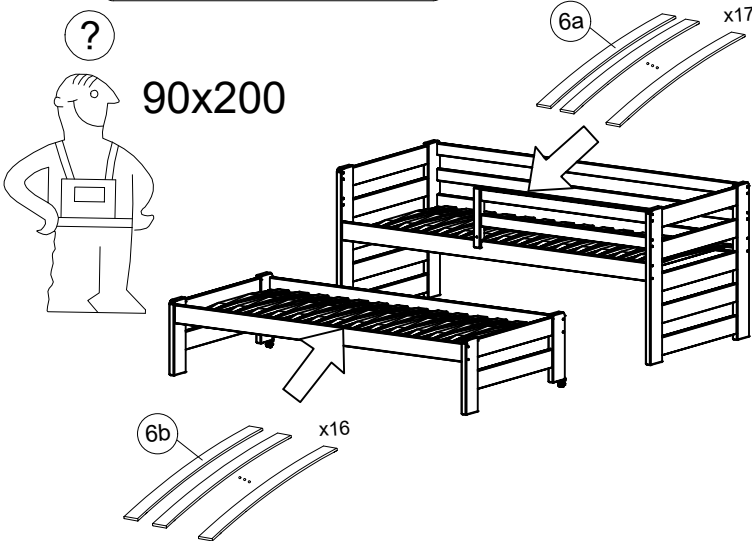

size / rozmiar	quantity of slats / ilość listew w zestawie
80x160	13
80x170	14
80x180	15
80x190	16
80x200	17
90x180	15
90x190	16
90x200	17

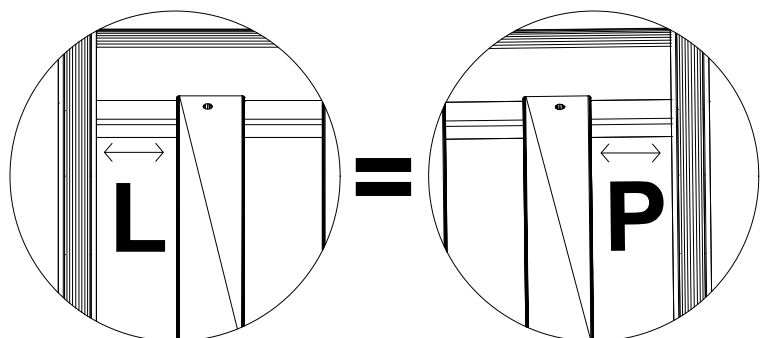
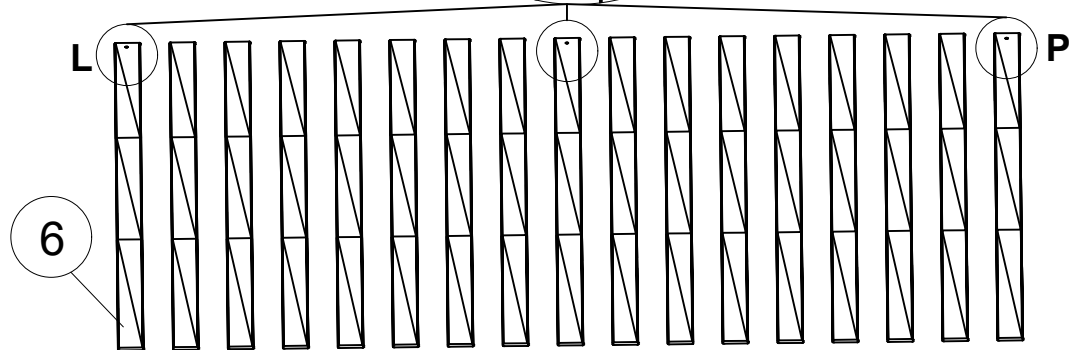

Možnosť žltnutia bielej povrchovej úpravy. Drevo je prírodný produkt, jehož žilovanie, štruktúra a farba podliehajú kolísaniu v dôsledku rastu, lokality a klímy. Časom sa navyše odtieň farby dreveného povrchu mení pod vplyvom svetla a tepla. Tento prírodný proces starnutia ovplyvňuje všetky typy dreva v menšej alebo väčšej miere.

Drevo nie je odolné voči svetlu. Pôsobenie slnečného svetla, ako aj rozptýlené denné svetlo vo vnútri miestností, prispieva najviac k zmene farby.

Miera zmeny odtieňa farby závisí nielen od uplynutého času, ale aj od umiestnenia nábytku.

Neviditeľné časti ako napríklad rámy, dno zásuviek, dosky podporujúce rám atď., nie sú maľované tak ako zvyšok postele.

Všetky skrutky a vkruty prosím vkrúcajte opatrne a pomaly, aby ste predišli praskaniu.

NESKRUTKUJTE kovania blízko hrán! (TO SA TÝKA HLAVNE ZÁSUVIEK).

POZOR! Produkt môže po zostavení vyvíjať zápach až 72 hodín.

There is a possibility of yellowing of the coating of white coloured beds.

Wood is a natural product, whose natural grain, texture and colour are subject to fluctuations associated with growth, location and climate. Moreover, hue of the wood surface varies over time as a result of light and heat.

This natural process of aging is subject to greater or lesser extent on all types of wood. Wood is not resistant to light. Sunlight as well as diffused light inside the room contribute the most to colour change. The degree of changes to the shade depends not only on the passing of time, but also on placement of the furniture.

Invisible elements such as slats, frame supporting the slats, bottoms of drawers, etc. are not painted as the rest of the bed.

All bolts and screws are to be screwed gently and slowly to avoid damaging the panels by cracks. Do not screw fittings close to the edges.

ATTENTION!

After assembling, please wipe the bed with a damp cloth. The product might give off a strong scent of paint after assembling, usually up to

72hours.