

# LIR 64

## 64BM

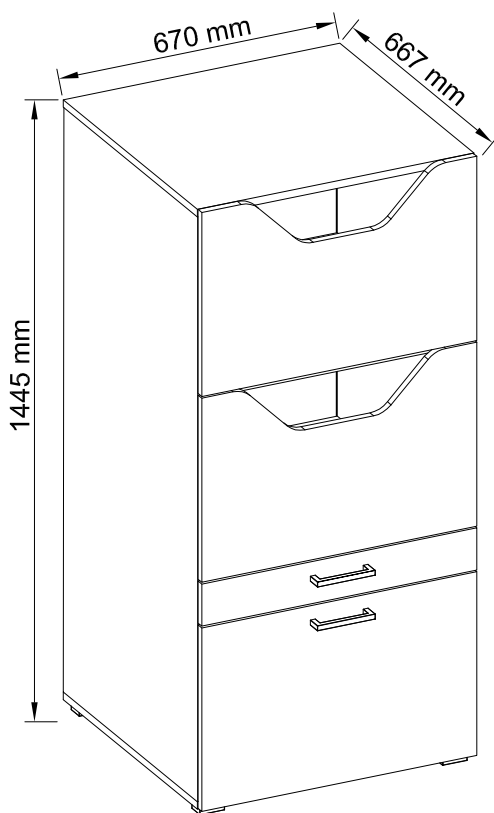

**D** **Montageanleitung**  
Kommode >Lir<

**FR** **Notice de montage**  
La commode >Lir<

**NL** **Handleiding voor de montage**  
Dressoir >Lir<

**CZ** **Montážní návod**  
Prádelník >Lir<

**HU** **Szerelési útmutató**  
Öltözködőasztal >Lir<

**TR** **Montaj talinati**  
Şifonyer >Lir<

**ES** **Instrucciones de montaje**  
Aparador >Lir<

**GB** **Assembly instructions**  
Dresser >Lir<

**IT** **Intruzioni di montaggio**  
Costumista >Lir<

**PL** **Instrukcja montażu**  
Komoda >Lir<

**SK** **Návod na montáž**  
Dresser >Lir<

**RO** **Instructiuni de montaj**  
Dulap >Lir<

**RU** **Инструкция по монтажу**  
Комод >Lir<

**PT** **Instruções de montagem**  
Cómoda >Lir<

**SRB** **Упутства за инсталацију**  
ГРУДИ фиоке >Lir<

**HR** **Upute za instalaciju**  
Komoda >Lir<

**SL** **Návod na montaž**  
Komoda >Lir<

**LT** **Surinkimo instrukcijos**  
Komoda >Lir<

**LV** **Montāžas instrukcija**  
Komoda >Lir<

**EE** **Kokkupaneku juhised**  
Komoda >Lir<

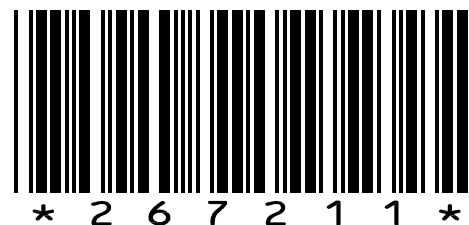
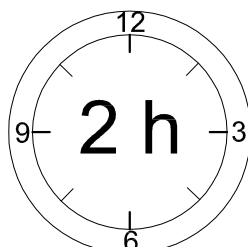
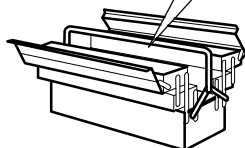
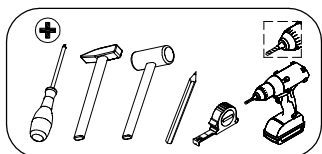
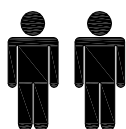

**D**-Ziehen Sie alle Schrauben sowie tragende Verbindungsteile nach ca. 5 Wochen nach, um eine dauerhafte Standsicherheit zu gewährleisten.

**GB**-After approx. 5 weeks, tighten all screws and load-bearing connecting parts to ensure permanent stability.

**FR**-Resserrez toutes les vis ainsi que les pièces de fixation au bout d'environ 5 semaines pour garantir une sécurité de fixation durable.

**IT**- Ristringere tutte le viti e giunture dopo ca. 5 settimane, al fine di garantire una durevole solidità.

**NL**-Draai alle schroeven en ook dragende verbindingstukken na ca. 5 weken nog eens vast, zodateen continue stabiliteit wordt gegarandeerd.

**PL**-Prosimy po ok. 5 tygodniach dokręcić wszystkie śruby i elementy łączeniowe. Zagwarantuje to Państwu trwałość i stabilność połączeń.

**CZ**- Dotáhněte všechny šrouby a nosné spojovací díly přibližně po 5 týdnech, aby se zaručila trvalá stabilita.

**SK**-Po cca 5 týždňoch dotiahnite skrutky, aby bola zaručená ich trvalá stabilita.

**HU**-Húzza utána - kb. 5 hét múlva - az összes csavart és a teherhordó összekötő-alkatrészeket abiztonság érdekében.

**RO**-Pentru a asigura o stabilitate de durată, strângeți după cca. 5 săptămâni toate șuruburile, precumși toate elementele portante de legătură.

**TR**-Tüm vida ve taşıyıcı bağlantı parçalarını kalıcı bir duruş güvenliğini sağlamak için yaklaşık 5 haftasonra tekrar sıkınız.

**RU** - Подкрутите все болты, а также несущие соединительные детали припл. через 5 недель для обеспечения устойчивости в течение длительного времени.

**SRB** - Molim vas posle akroksa. 5 nedelja zategnite sve šrafove i pričvršćivače. To ће вам гарантовати трајност и стабилност веза.

**HR** - Molim vas, nakon cca. 5 tjedana zategnite sve vijke i pričvršćivače. To će vam jamčiti trajnost i stabilnost priključaka.

**SL** - Pýtame sa po cca. 5 týždňov utiahnite všetky skrutky a upevňovacie prvky. To zaručuje trvanlivosť a stabilitu spojov.

**LT** - Mes prašome po maždaug. 5 savaites priveržkite visus varžtus ir tvirtinimo detales. Taip užtikrinamas jungčių patvarumas ir stabilumas.

**LV** - Mēs lūdzam pēc apm. 5 nedēļas, pievelciet visas skrūves un stiprinājumus. Tas garantē savienojumu izturību un stabilitāti.

**EE** - Küsime pärast ca. 5 nädalat, pingutage kõiki kruvisid ja kinnitusi. See tagab ühenduste vastupidavuse ja stabiilsuse.

**ES** - Apriete todos los tornillos y elementos de conexión después de aprox. 5 semanas. Esto le garantizará la durabilidad y estabilidad de sus conexiones.

**PT** - Aperte todos os parafusos e elementos de ligação após aprox. 5 semanas. Isto garantirá a durabilidade e a estabilidade das suas ligações.

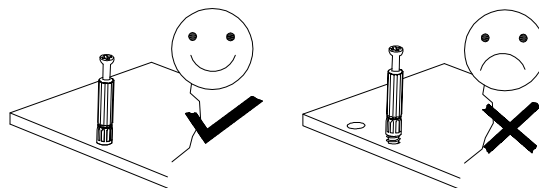

**D** Bitte nur mit einem Staubtuch oder leicht feuchtem Lappen reinigen. Keine scheuernden Putzmittel verwenden.

**GB** Please only clean with a duster or a damp cloth. Do not use any abrasive cleaners.

**FR** Veuillez nettoyer uniquement avec un chiffon à poussière ou un chiffon légèrement humide. Ne pas utiliser de détergent abrasif.

**IT** Si raccomanda di pulire solo con un panno per la polvere o uno strofinaccio umido. Non utilizzare detersivi abrasivi.

**NL** Reinig alleen met een stofdoek of een lichtjes vochtige doek. Gebruik geen schurende poetsmiddelen.

**PL** Czyszczenie należy wykonać wyłącznie za pomocą ściereczki lub lekko nawilżonego ręcznika. Nie stosować środków czyszczących do szorowania.

**CZ** Čistěte prosím jen prachovkou nebo lehce navlhčeným hadrem. Nepoužívejte drhnutí čistící prostředky.

**SK** Na čistenie používajte len prachovku alebo zľahka navlhčenú utierku. Nepoužívajte žiadne drhúce čistiace prostriedky.

**HU** Kérjük, csak portórlő kendővel vagy enyhén nedves ronggyal tisztítsa. Ne használjon dörzshatású tisztítószert.

**RO** Vă rugăm să utilizați la curățare exclusiv o cârpă de șters praful sau o cârpă ușor umezită. Nu utilizați substanțe de curățat abrazive.

**TR** Lütfen sadece bir toz bezıyla veya hafif nemli yumuşak bir bezle siliniz. Aşındırıcı temizlik malzeme-meleri kullanmayınız.

**RU** Для чистки используйте, пожалуйста, тряпку для пыли или слегка влажную ветошь. Неиспользовать абразивные чистящие средства.

**SBR** Чишћење треба обавити само крпом или благо влажним пешкиром. Немојте користити средство за чишћење рибања.

**HR** Čišćenje treba obaviti samo krpom ili blago navlaženim ručnikom. Ne koristite sredstva za čišćenje ribanja.

**SL** Čistenie by sa malo vykonávať len handričkou alebo ľahko navlhčeným uterákom. Nepoužívajte čistiace prostriedky na drhnutie.

**LT** Valyti galima tik šluoste arba lengvai sudrėkintu rankšluosčiu. Nenaudokite šveičiamųjų valiklių.

**LV** Tīršana jāveic tikai ar drānu vai viegli samitrinātu dvieli. Neizmantojiet tīršanas līdzekļus.

**EE** Puhastada tohib ainult lapiga või kergelt niisutatud rätikuga. Ärge kasutage puhastusvahendeid.

**PT** A limpeza deve ser feita apenas com um pano ou toalha ligeiramente húmida. Não utilize produtos de limpeza abrasivos.

**ES** La limpieza debe realizarse únicamente con un paño o toalla ligeramente húmedo. No utilice agentes de limpieza abrasivos.

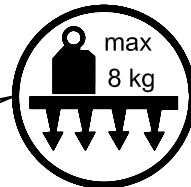
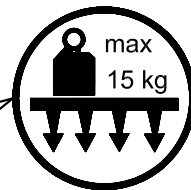
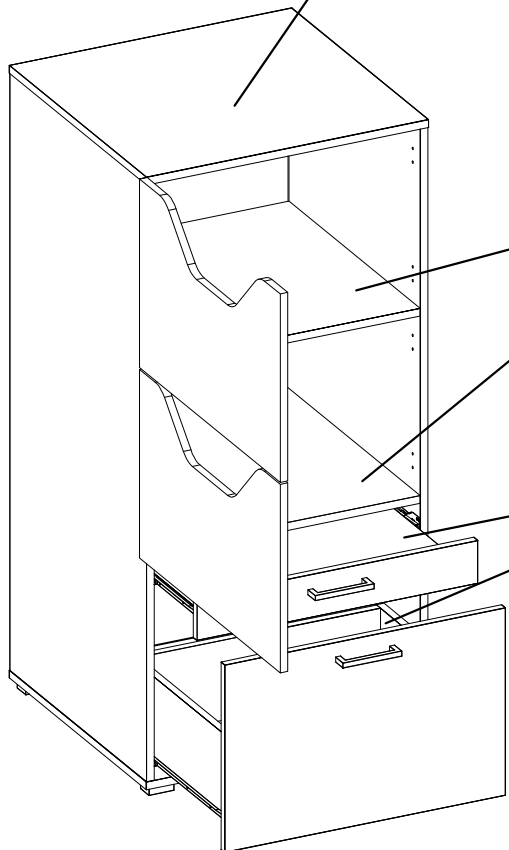
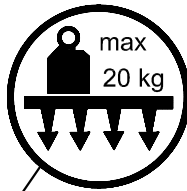
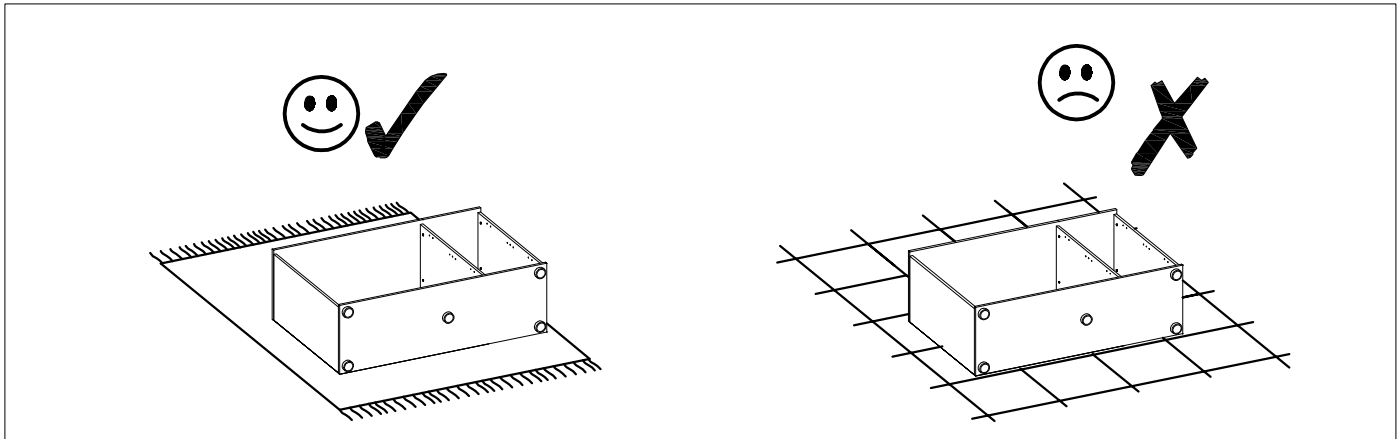
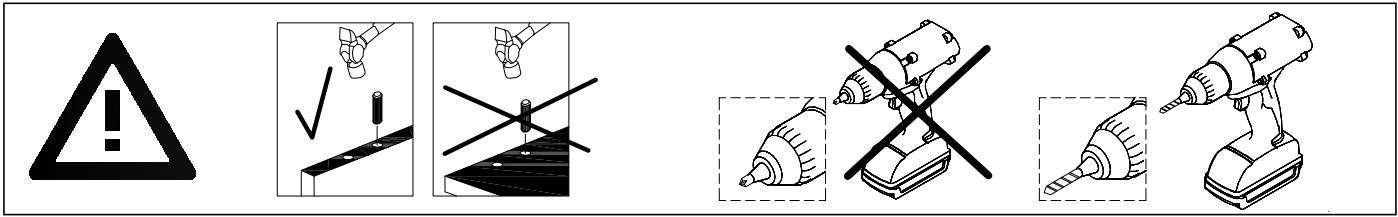
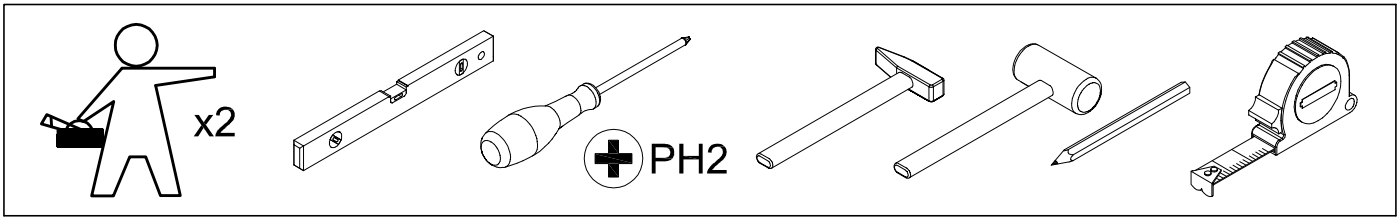

**Service · Assistenza · Dienstverlening · Serwis  
Servis · Szerviz · Сервисная служба · Сервис · Serwis · Servis**

Name · Nom · Nome · Naam · Nazwa · Jméno · Názov · Név · Denumire · Isim · Название	LIR	
Typ · Type · Tip · Tipus · Тиро · Тип	64	

<b>A</b> Ø8x30 mm  x24 3989	<b>B</b> Ø15x12 mm  x24 3996	<b>C</b> Ø6,5x36,5 mm  x24 4066	<b>D</b> Ø6,4x50 mm  x4 3884	<b>E</b> 4mm  x1 3984
<b>F</b> Ø20 mm  x18 136239	<b>G</b> Ø3,5x16 mm  x22 3918	<b>H</b> Ø4,0x25 mm  x4 145556	<b>I</b> Ø6,0x13 mm  x12 3877	<b>J</b> Ø4,0x20 mm  x8 IN01613
<b>K</b> 75x15x32 mm  x2 71900	<b>L</b> 15x14x11 mm  x10 4044	<b>M</b> L-500 mm  x2 92379	<b>N</b> 10x10-128 mm  x2 167314	
<b>O</b> L- 482 mm  x1 237173	<b>P</b> Ø35 mm , KR0  x4 IN01640	<b>R</b> 60x40x20 mm  x4 202689	<b>S</b> Ø35 mm  x4 262470	

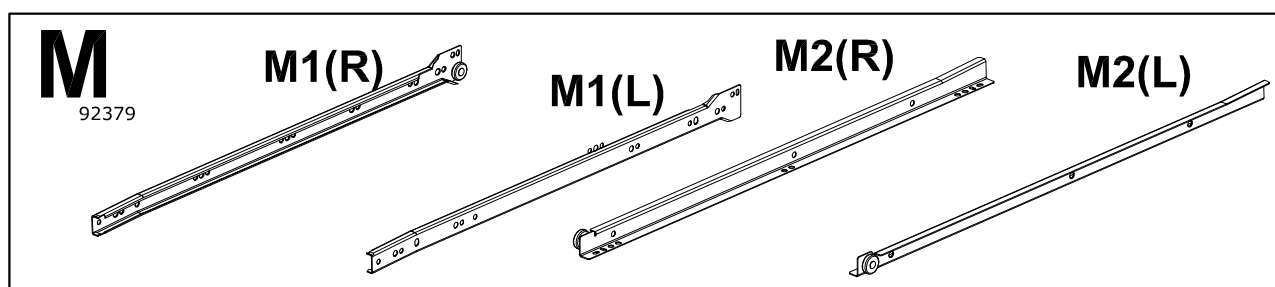
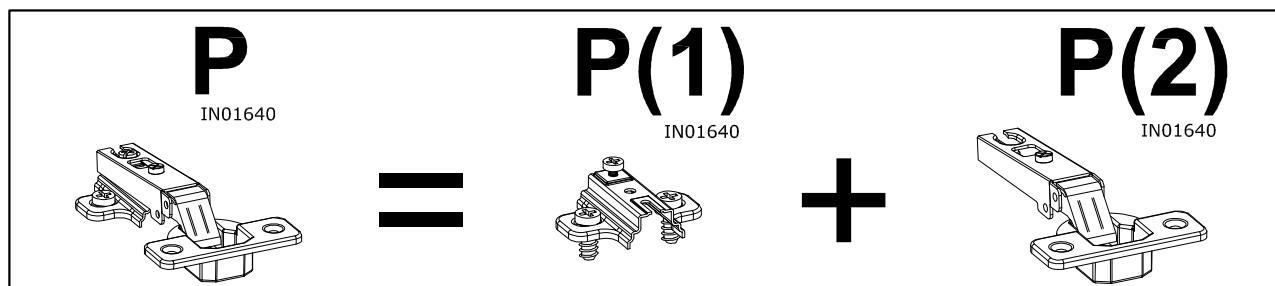

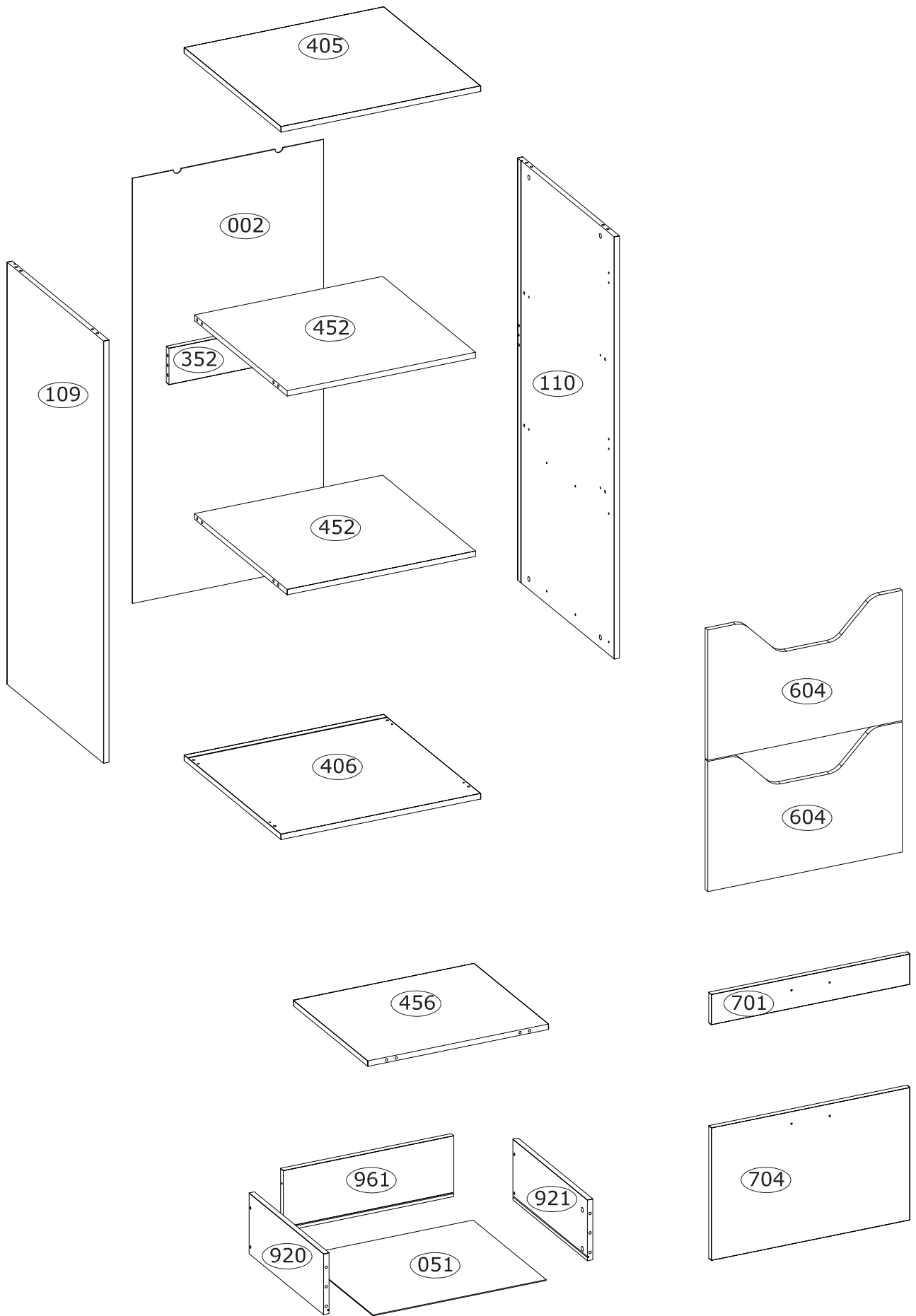

1

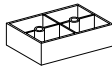
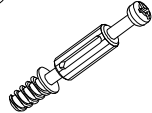
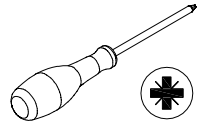
<b>J</b> Ø4,0x20 mm  x8 IN01613	<b>R</b> 60x40x20 mm  x4 202689	<b>C</b> Ø6,5x36,5 mm  x4 4066	
--	--	--	--

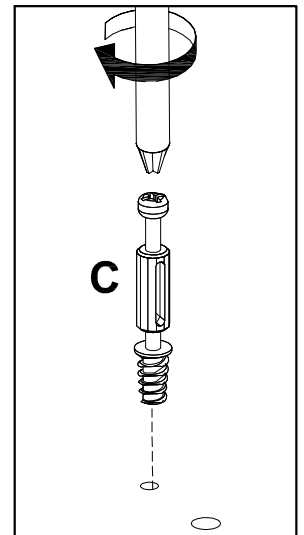
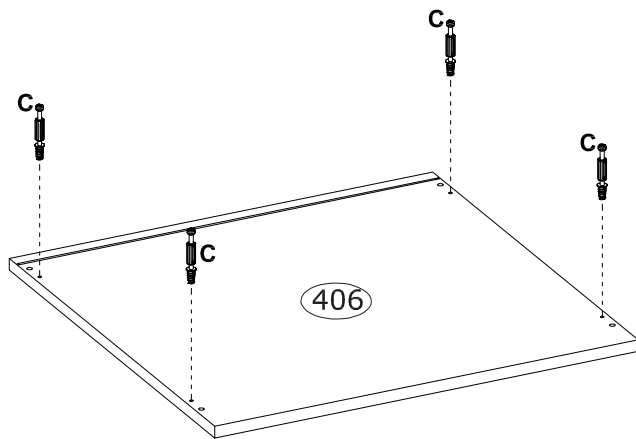
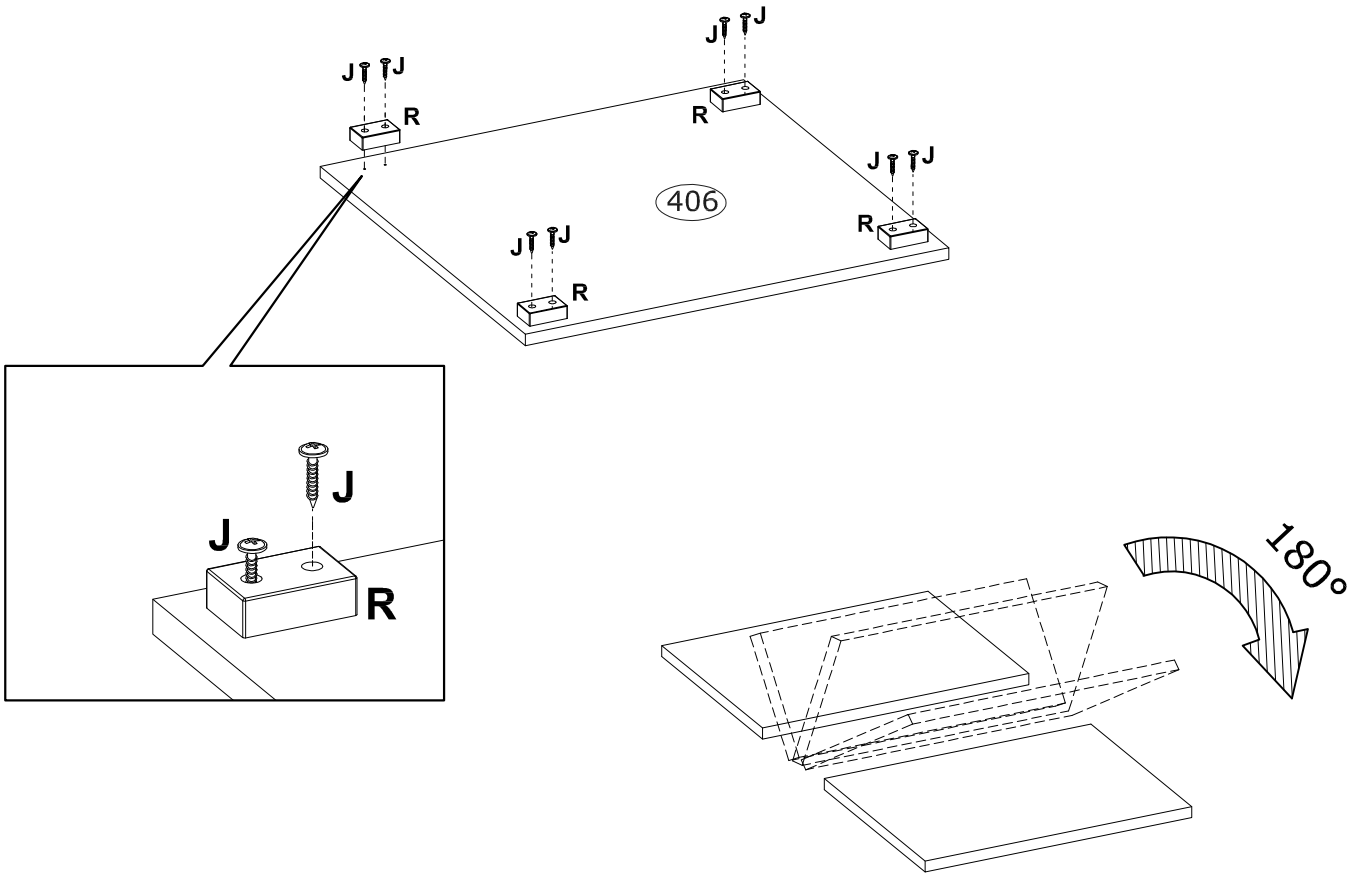

2

**A**  $\varnothing 8 \times 30$  mm  
x8  
3989

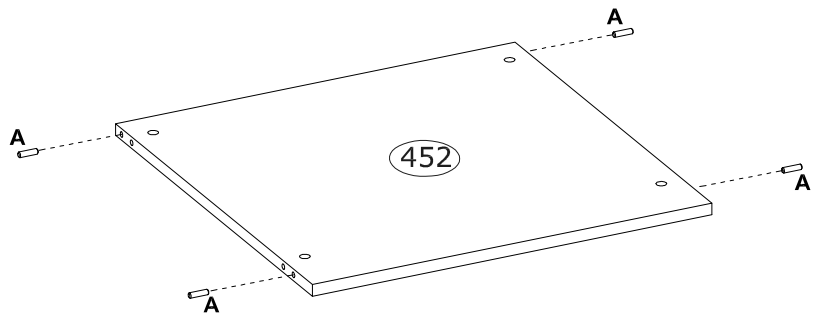
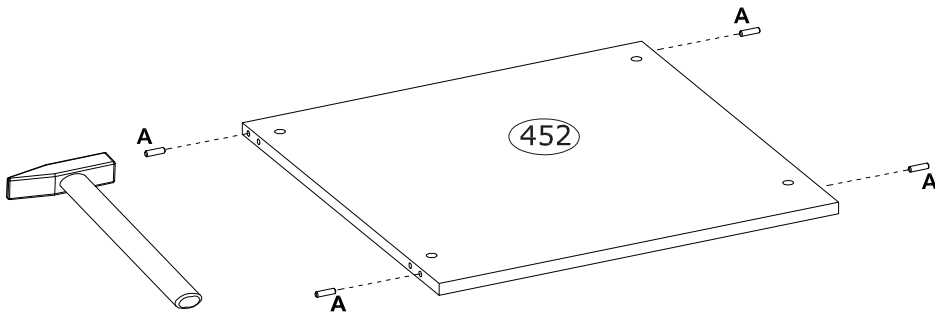
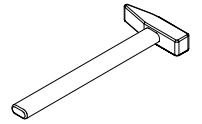

3

**C**  $\varnothing 6,5 \times 36,5$  mm  
x4  
4066

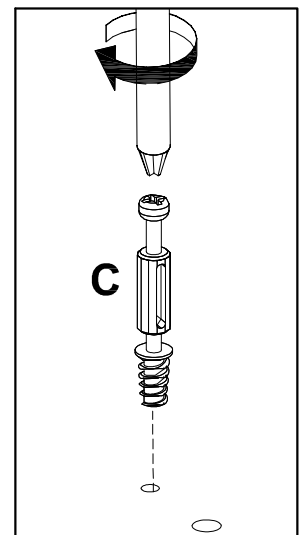
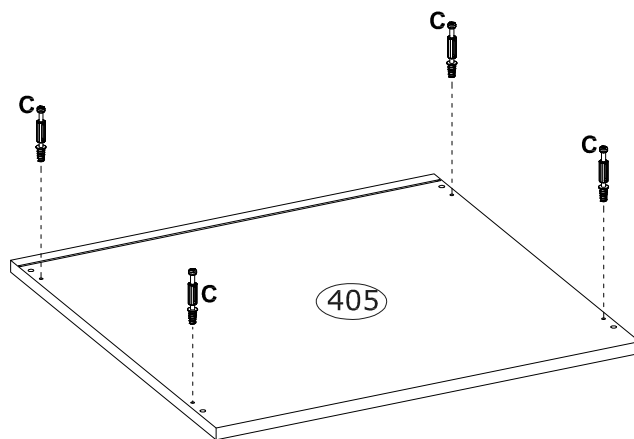
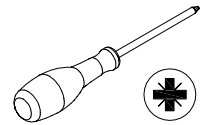

4

**A**  $\varnothing 8 \times 30$  mm  
x4  
3989

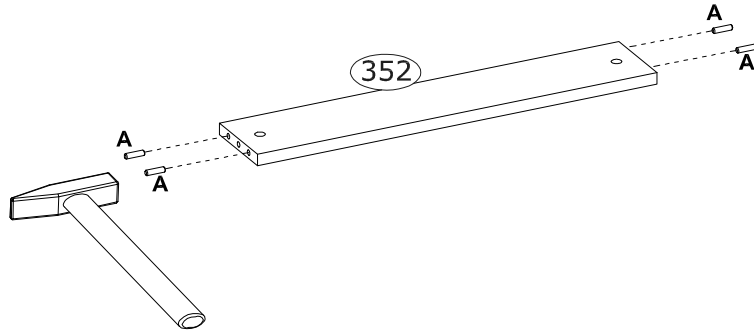
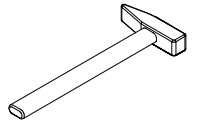

5

**A**  $\varnothing 8 \times 30$  mm  
x4  
3989

**C**  $\varnothing 6,5 \times 36,5$  mm  
x5  
4066

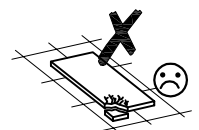
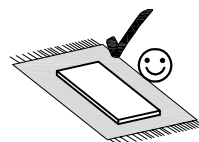
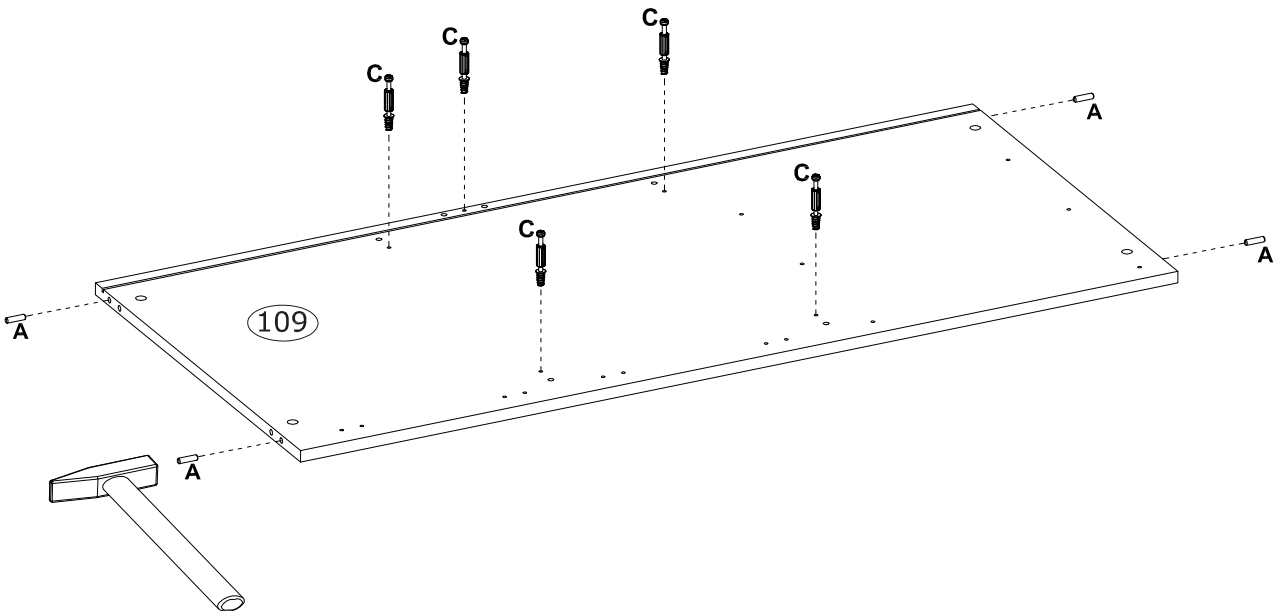
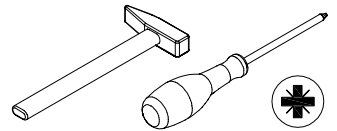

6

<b>A</b>	Ø8x30 mm	<b>C</b>	Ø6,5x36,5 mm	
	x4 3989		x5 4066	

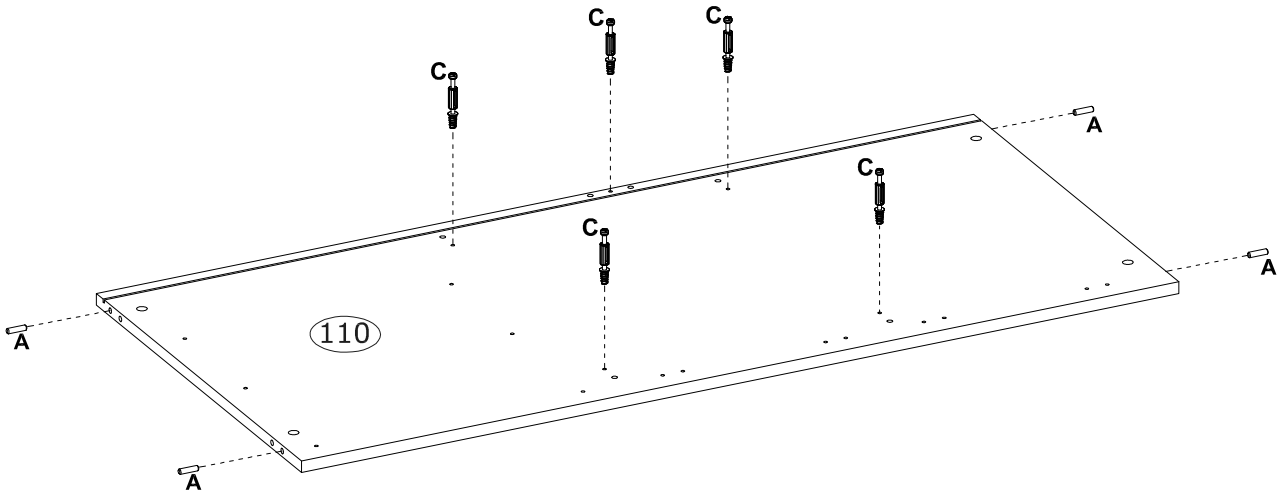

7

<b>B</b>	Ø15x12 mm	<b>F</b>	Ø20 mm	
	x4 3996		x4 136239	

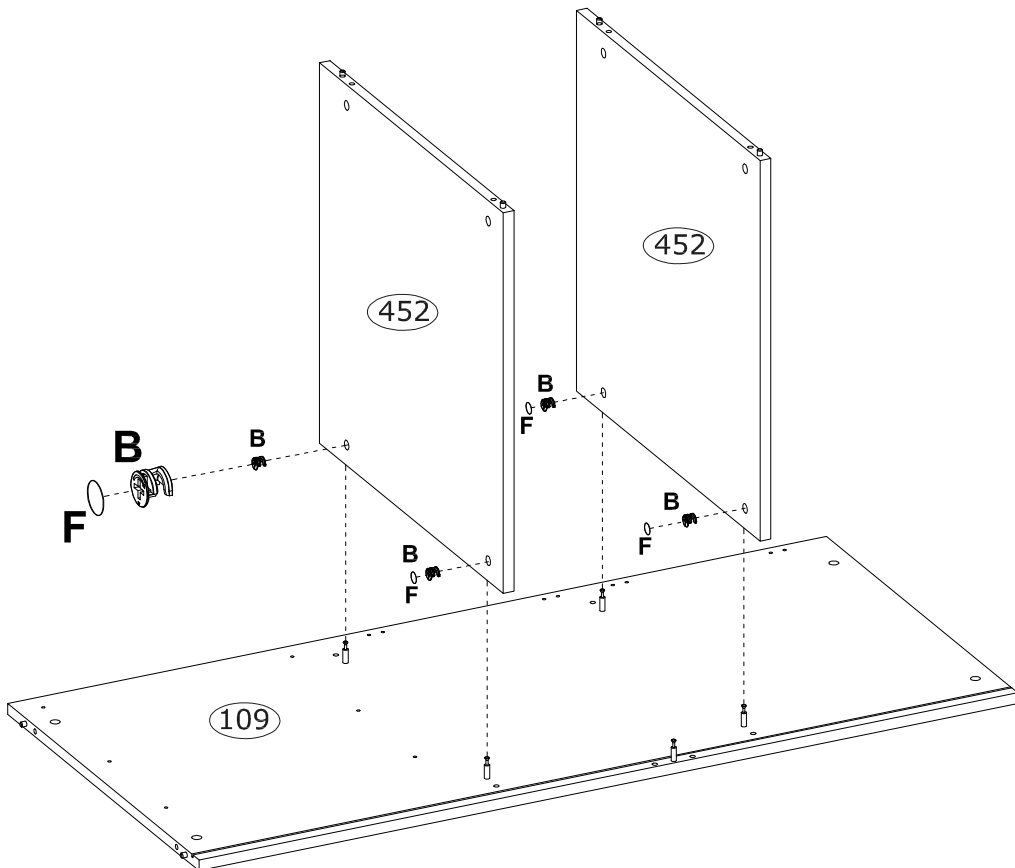

8

**B** Ø15x12 mm  
x1  
3996

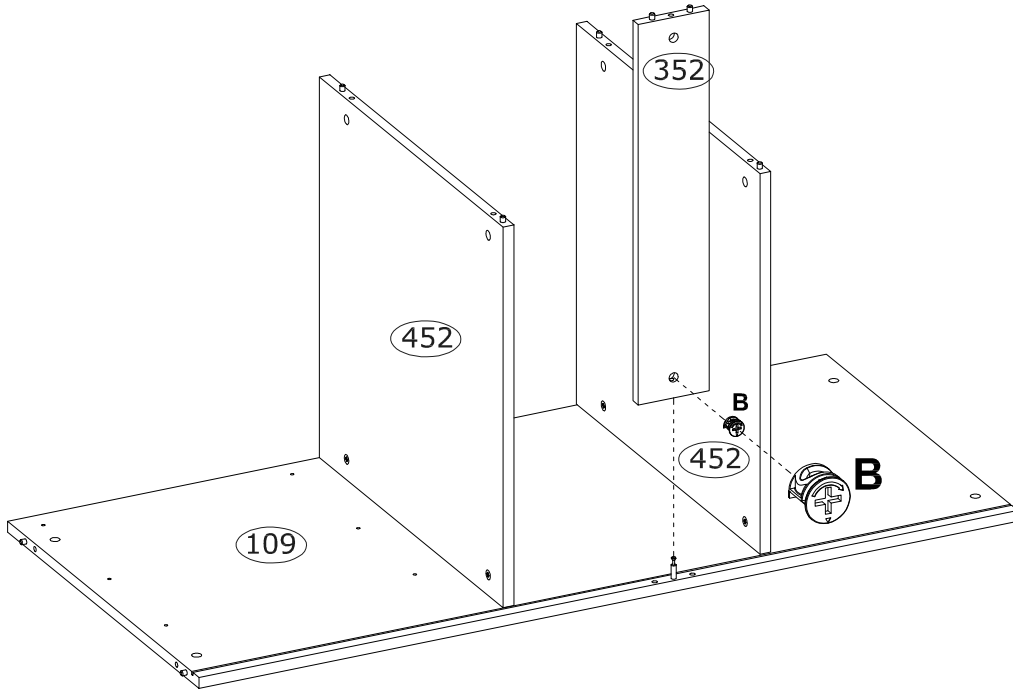
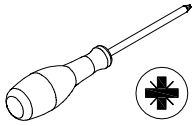

9

**B** Ø15x12 mm  
x5  
3996

**F** Ø20 mm  
x4  
136239

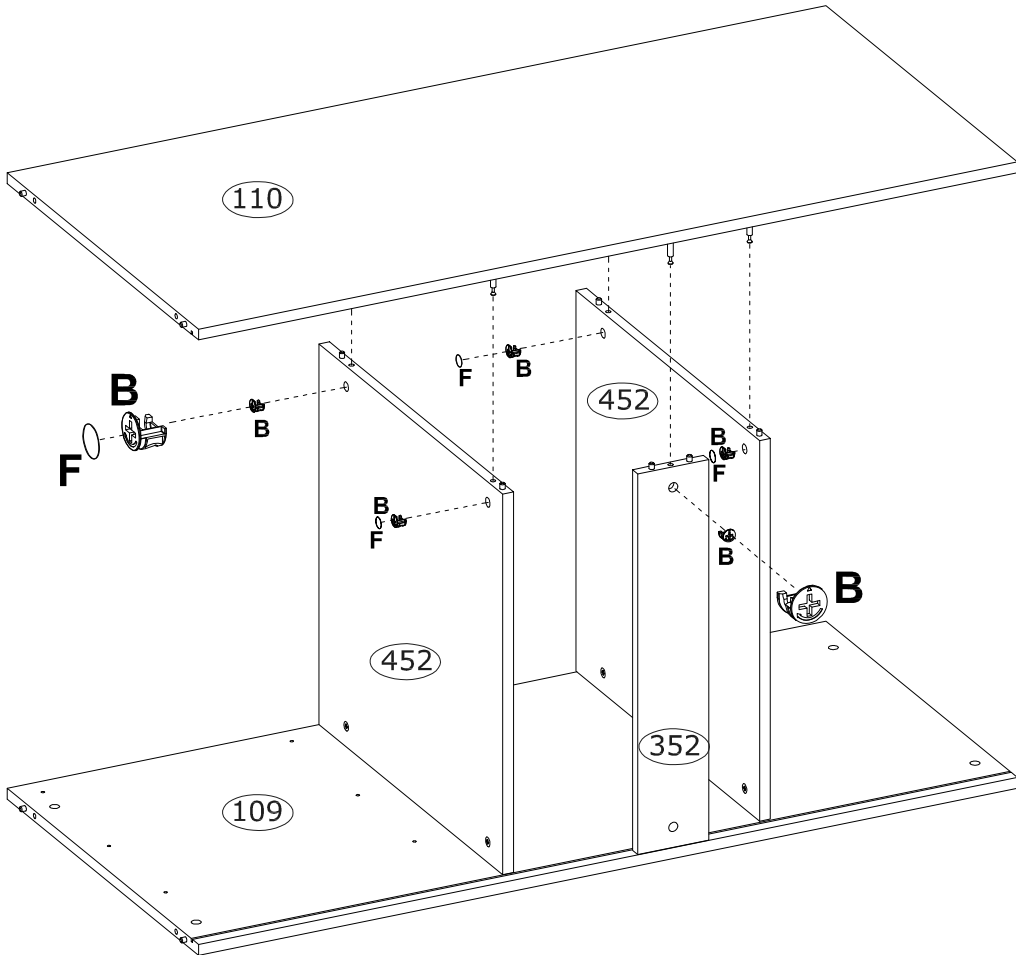
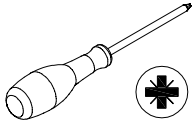

10

**B** Ø15x12 mm  
x4  
3996

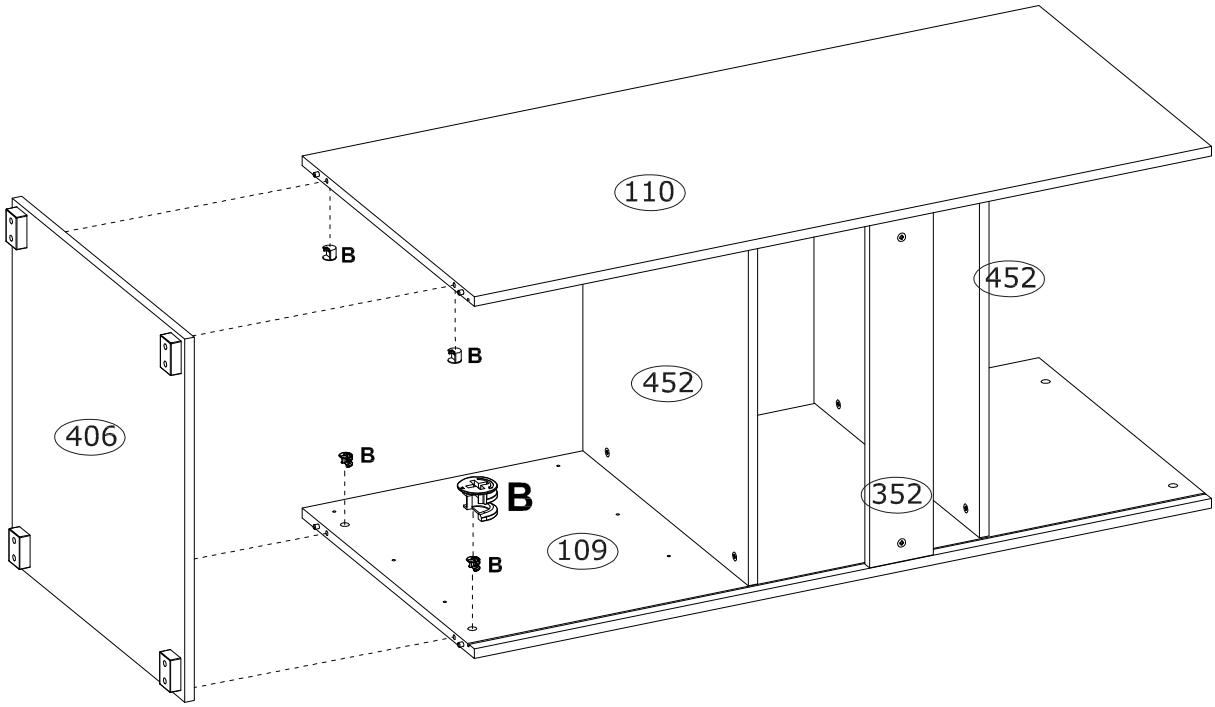
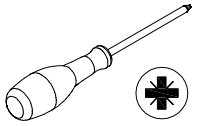

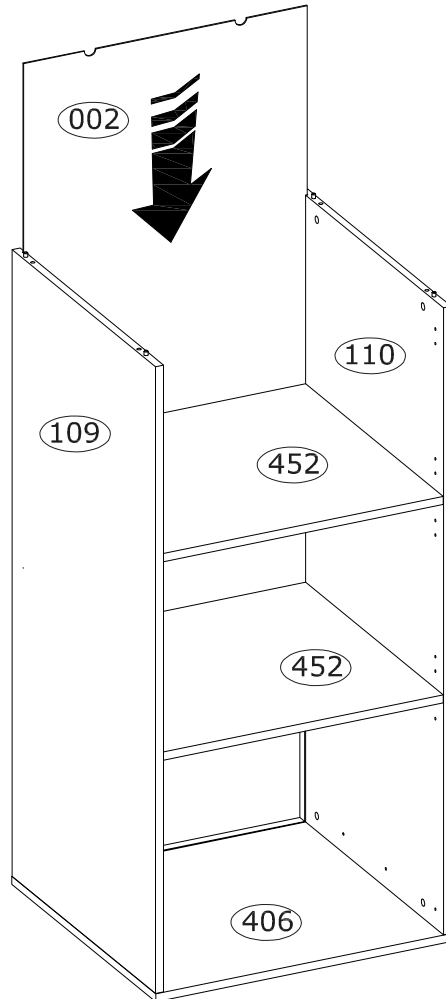

11

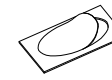
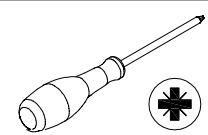

12

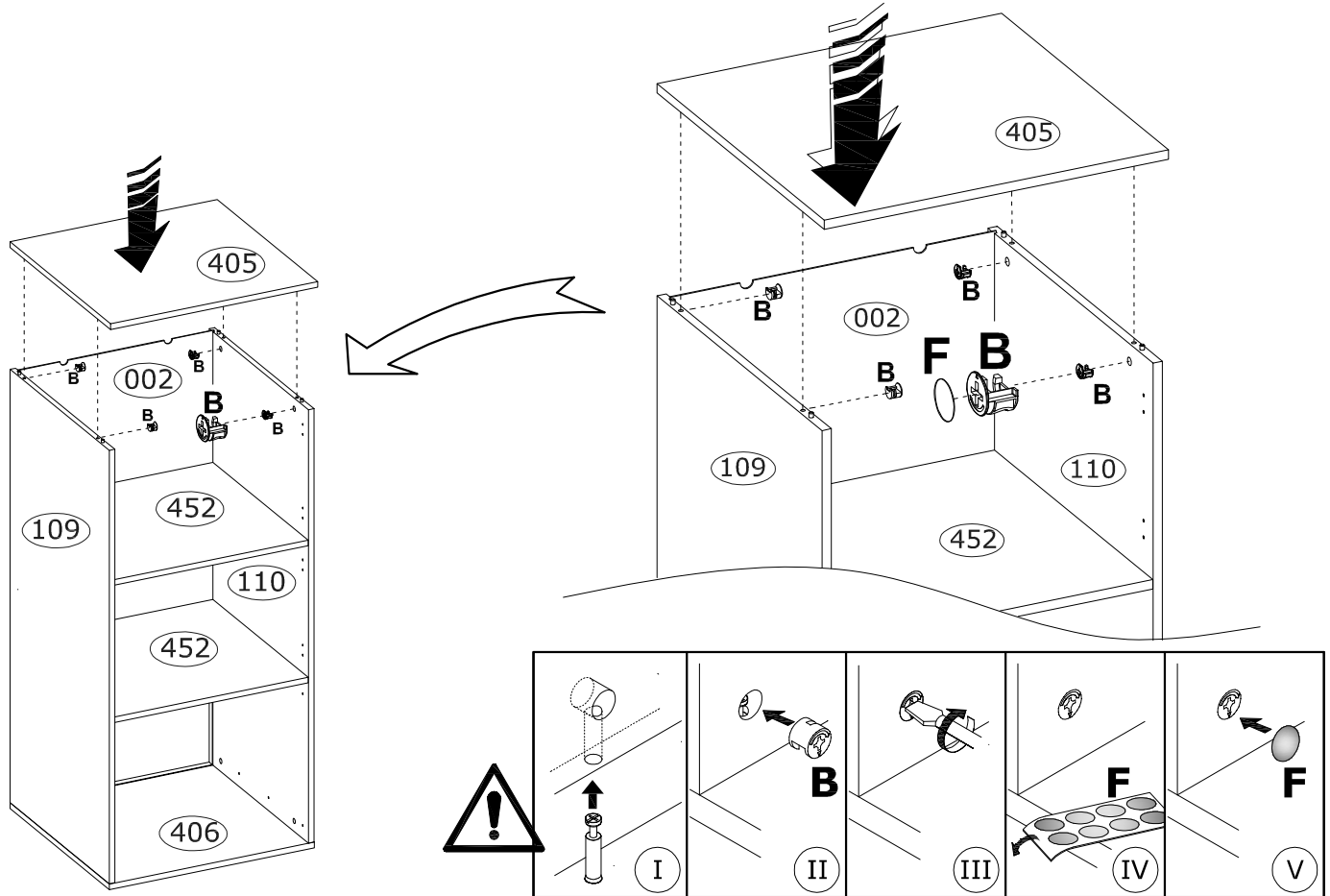
<p><b>B</b> <math>\varnothing 15 \times 12</math> mm</p>  <p>x4 3996</p>	<p><b>F</b> <math>\varnothing 20</math> mm</p>  <p>x4 136239</p>	
---	---	--



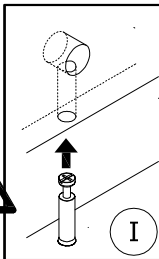
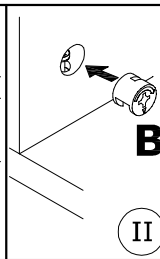
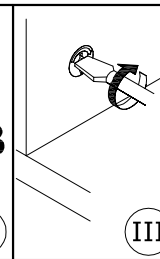
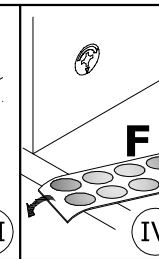
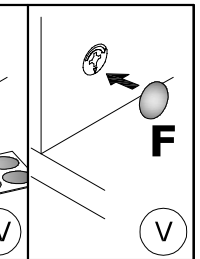



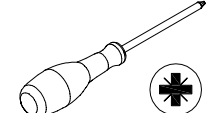

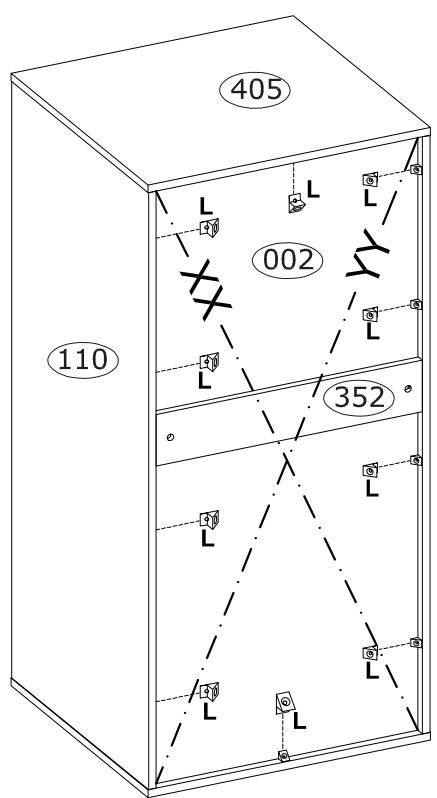

13

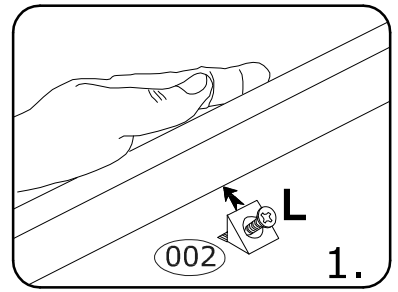
<p><b>L</b> 15x14x11 mm</p>  <p>x10 4044</p>	
---	---



$XX=YY \cong 90^\circ$



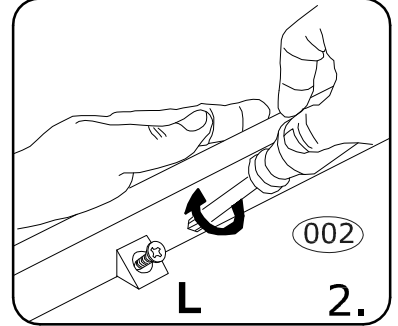

1.

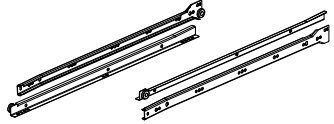

2.

14

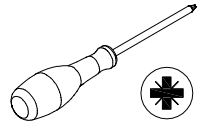
<p><b>M</b></p>  <p>L-500 mm</p> <p>x2 92379</p>	<p><b>I</b></p>  <p>Ø6,0x13 mm</p> <p>x12 3877</p>	
--	---	--

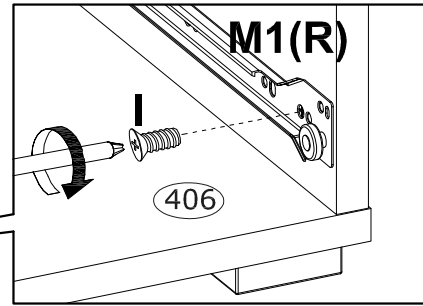
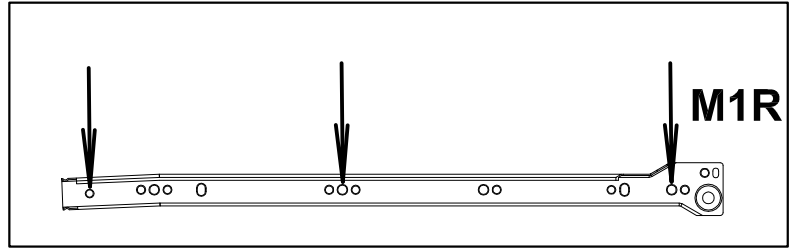
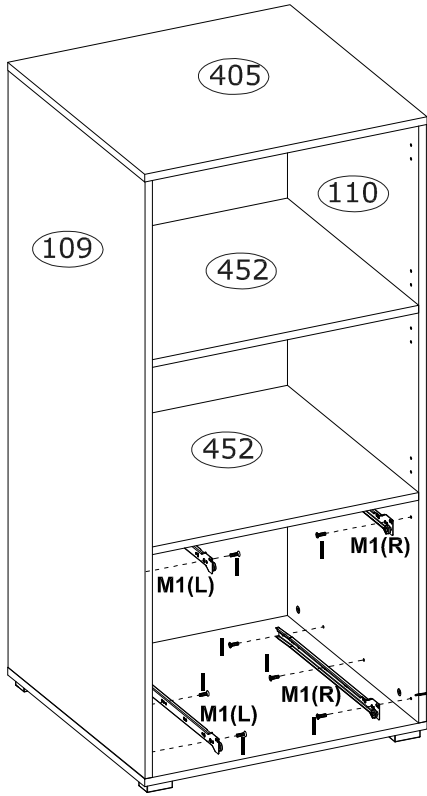

**M** 92379

**M1(R)**



**M1(L)**

**M2(R)**

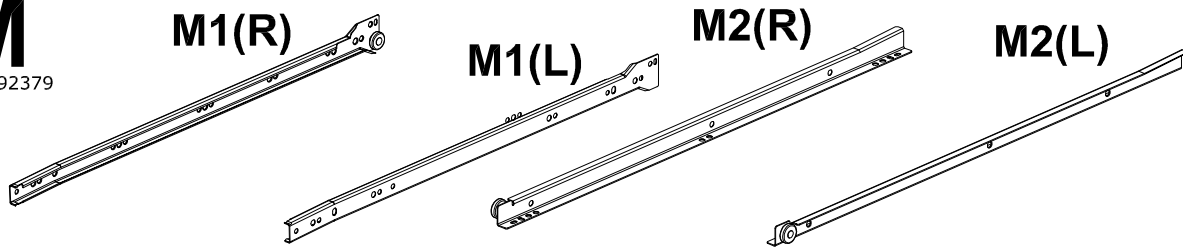
**M2(L)**





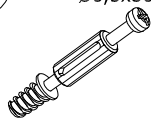
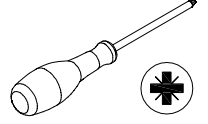

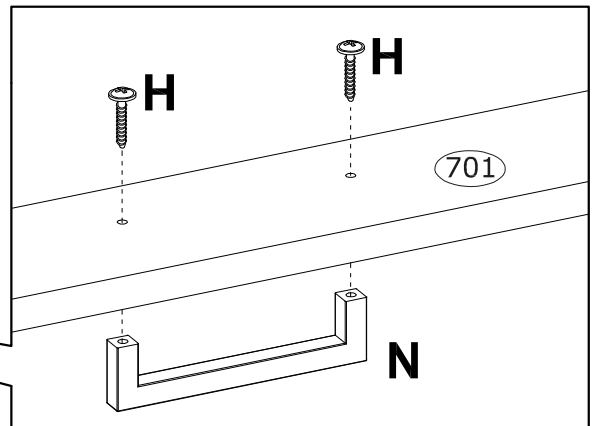
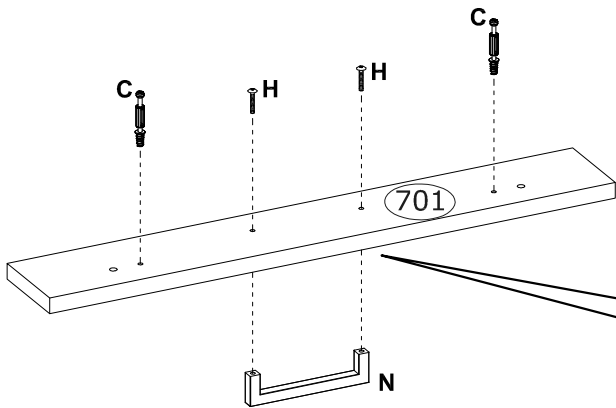
15

<p><b>H</b></p>  <p>Ø4,0x25 mm</p> <p>x2 145556</p>	<p><b>N</b></p>  <p>10x10-128 mm</p> <p>x1 167314</p>	<p><b>C</b></p>  <p>Ø6,5x36,5 mm</p> <p>x2 4066</p>	
--	--	--	---

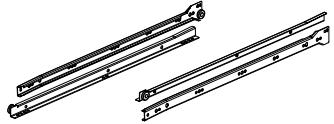

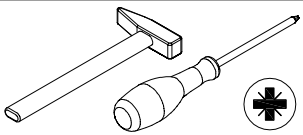
16

<b>M</b>  L-500 mm x1 92379	<b>G</b>  Ø3,5x16 mm x4 3918	<b>A</b>  Ø8x30 mm x2 3989	 
---	---	--	---

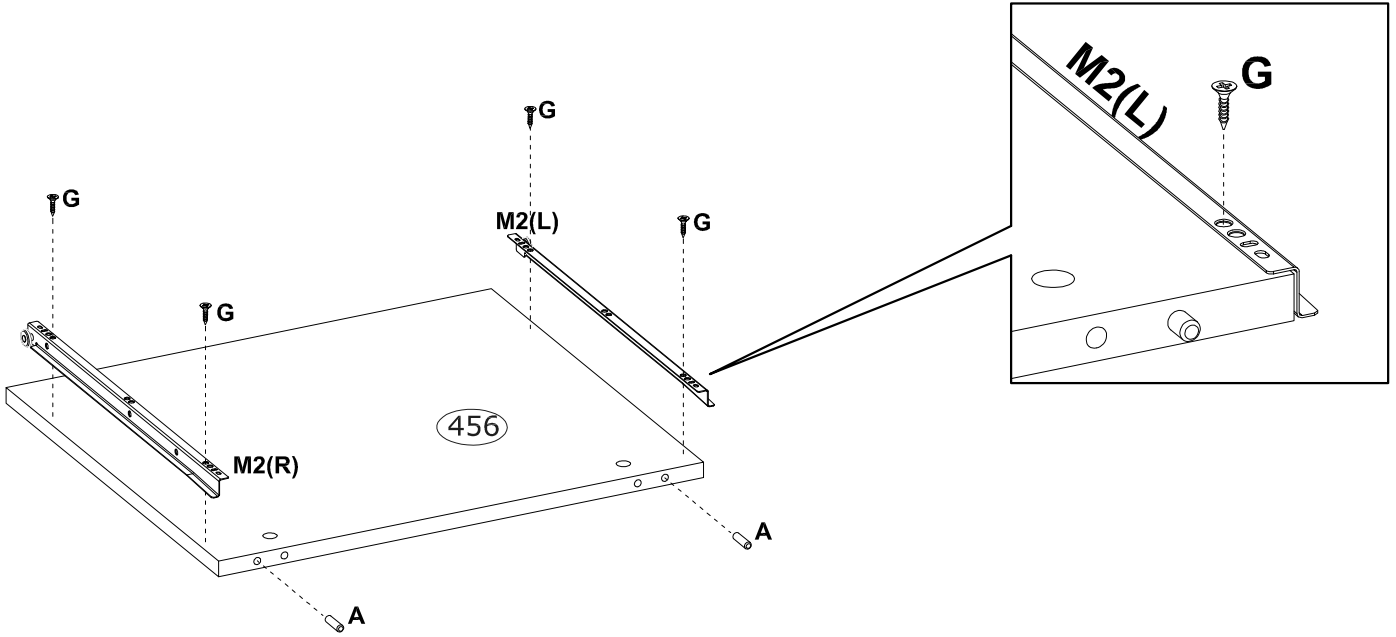

**M** 92379

M1(R)      M1(L)      M2(R)      M2(L)

17

<b>B</b>  Ø15x12 mm x2 3996	<b>F</b>  Ø20 mm x2 136239	 
--	---	--

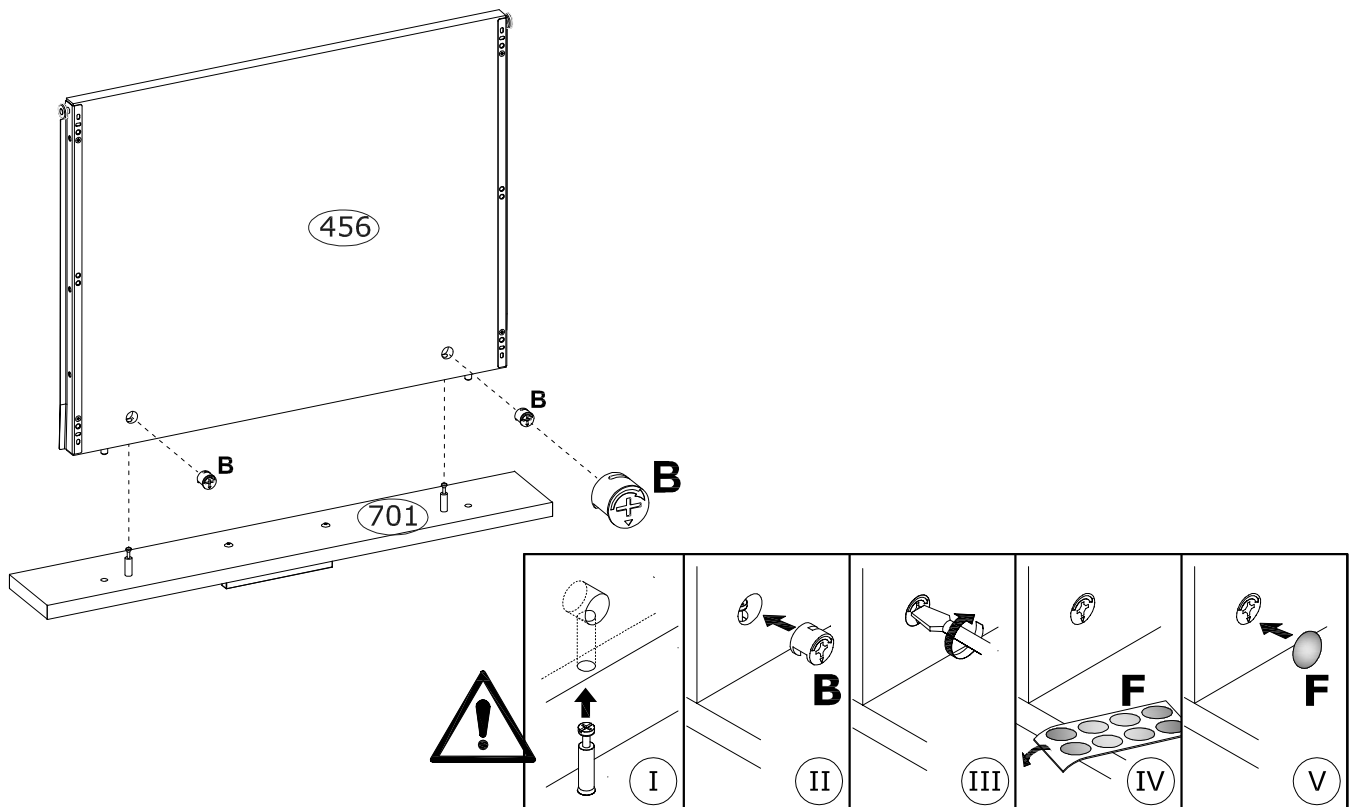

18

**A**  $\varnothing 8 \times 30$  mm  
x2  
3989

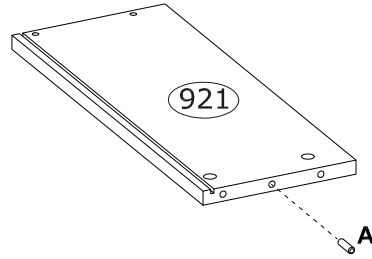
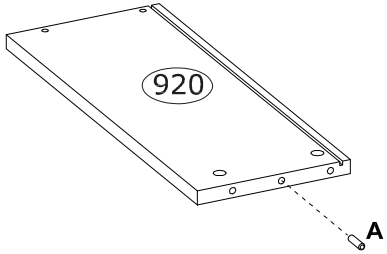
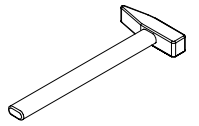
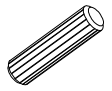

19

**D**  $\varnothing 6,4 \times 50$  mm  
x4  
3884

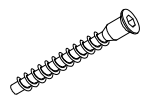

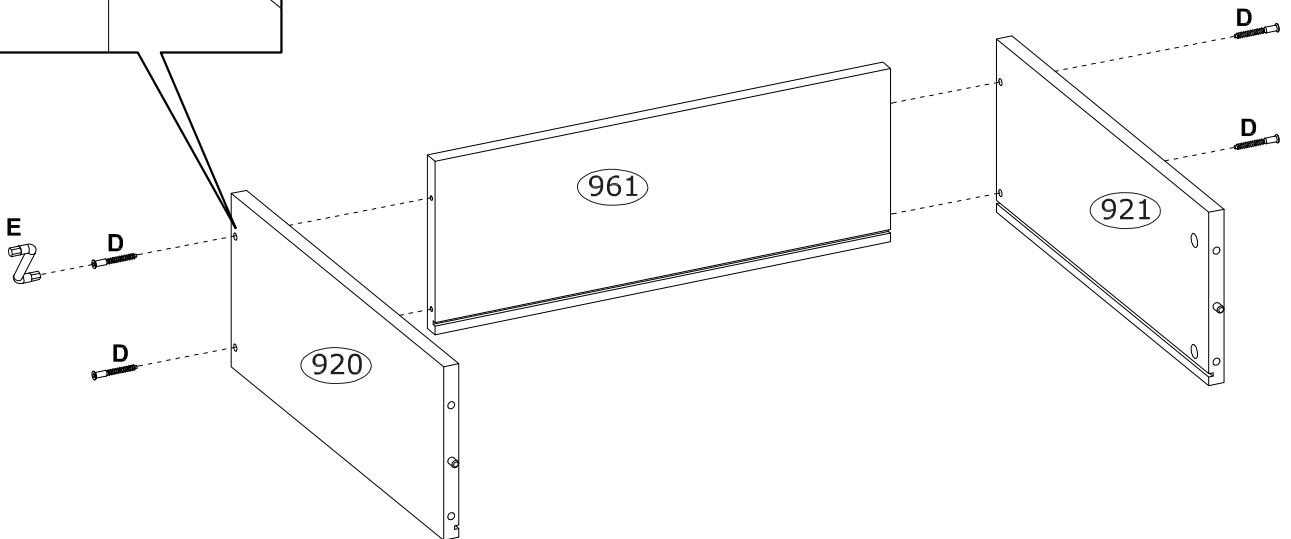
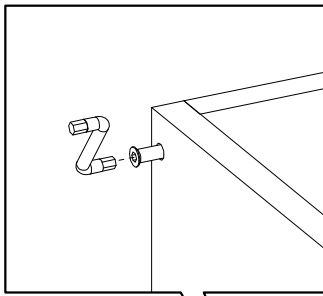
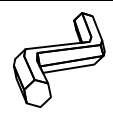

**E** 4mm  
3984

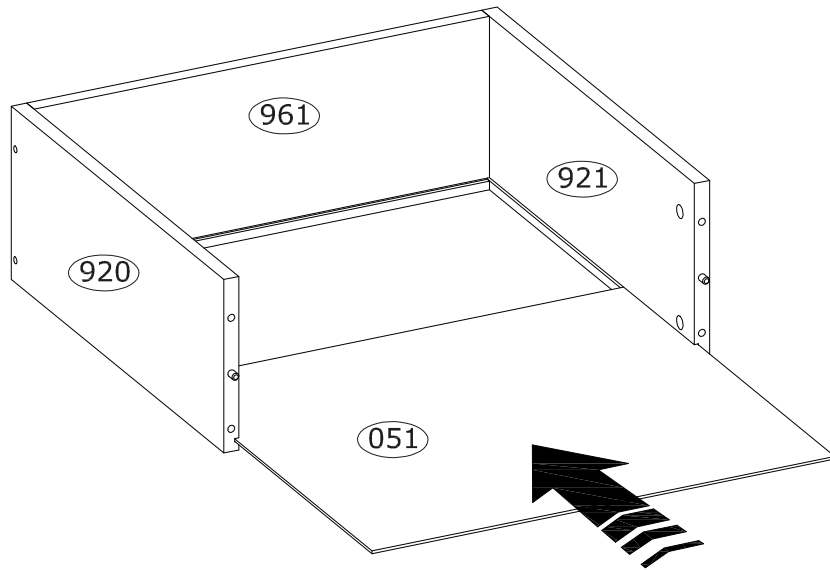

20

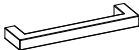

21

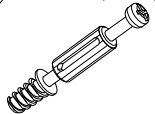
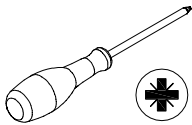
<p><b>N</b> 10x10-128 mm</p>  <p>x1 167314</p>	<p><b>H</b> Ø4,0x25 mm</p>  <p>x2 145556</p>	<p><b>C</b> Ø6,5x36,5 mm</p>  <p>x4 4066</p>	
---	---	---	---

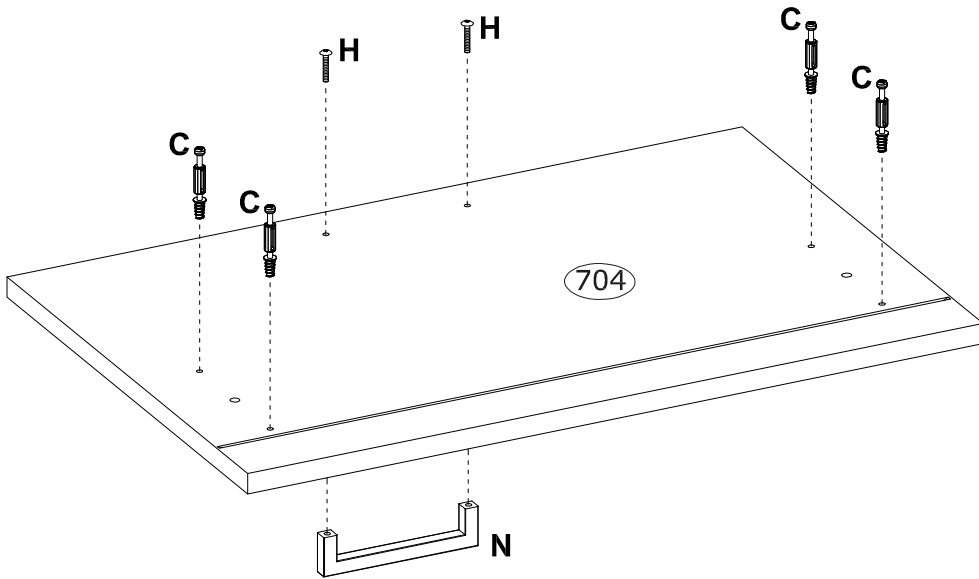

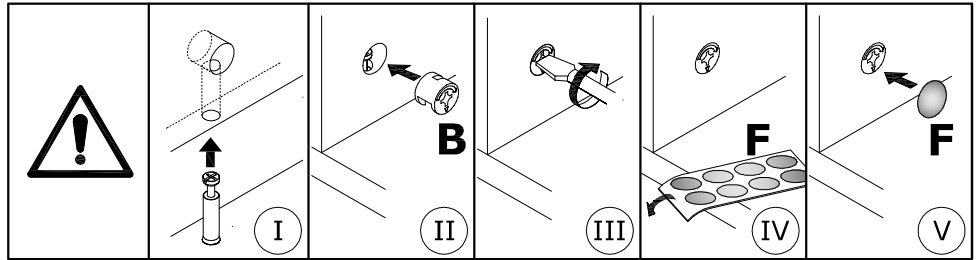
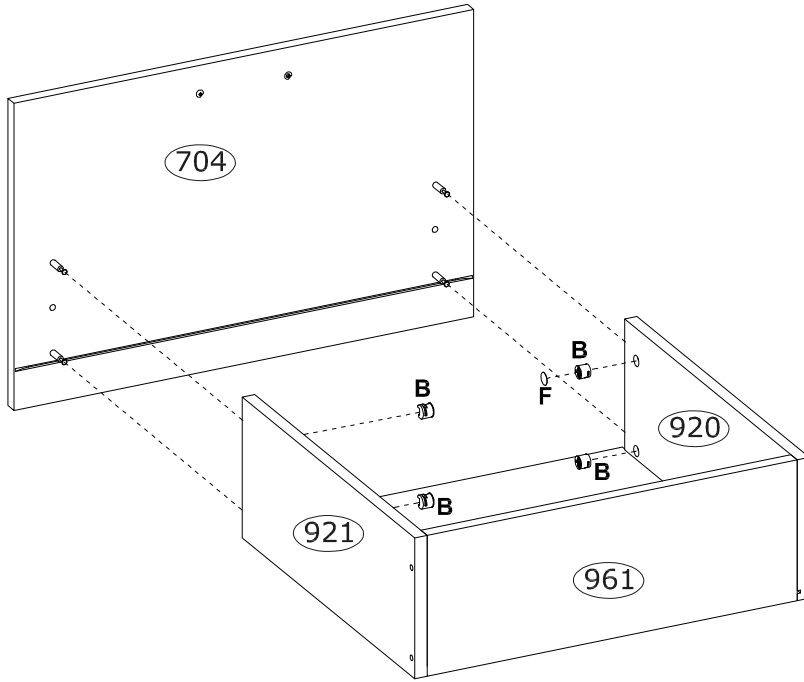

22

<b>B</b> Ø15x12 mm  x4 3996	<b>F</b> Ø20 mm  x4 136239	
--	---	--



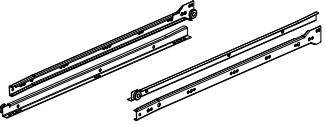

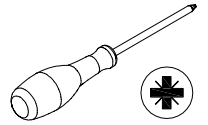
23

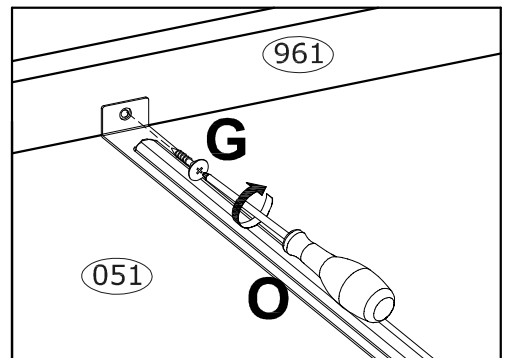
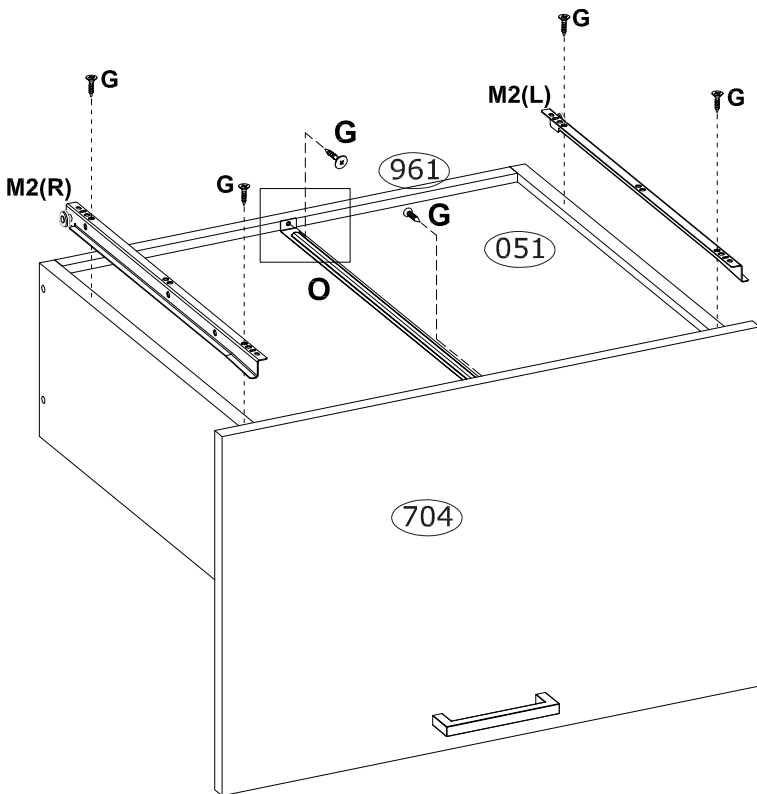
<b>M</b>  L-500 mm x1 92379	<b>G</b> Ø3,5x16 mm  x6 3918	<b>O</b> L- 482 mm  x1 237173	
--	---	---	---

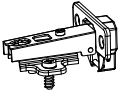

24

**P** Ø35 mm , KR0  
  
 x4  
 IN01640

**G** Ø3,5x16 mm  
  
 x8  
 3918

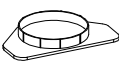
**S** Ø35 mm  
  
 x4  
 262470

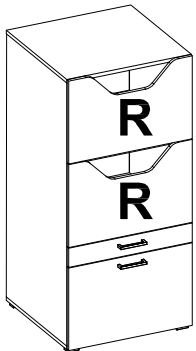
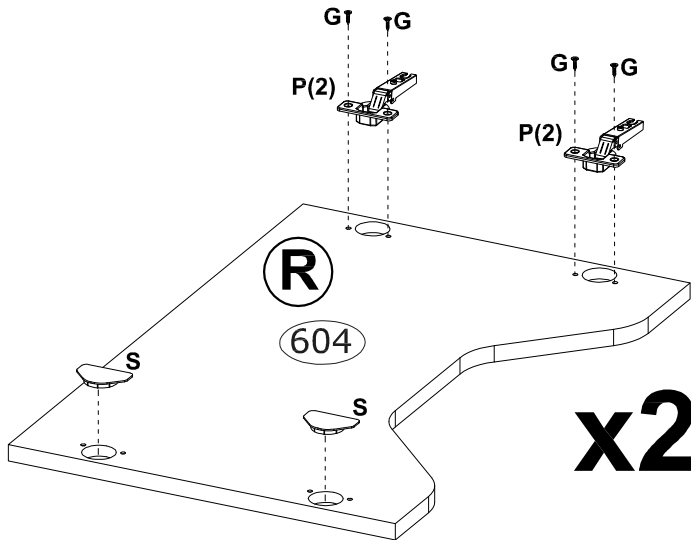
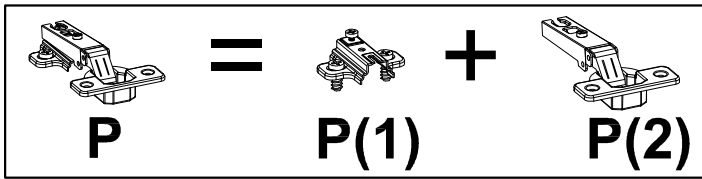
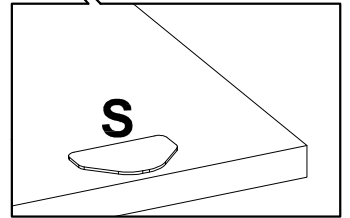
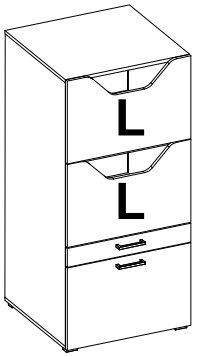
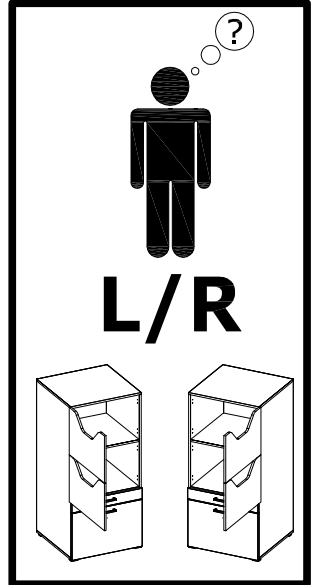
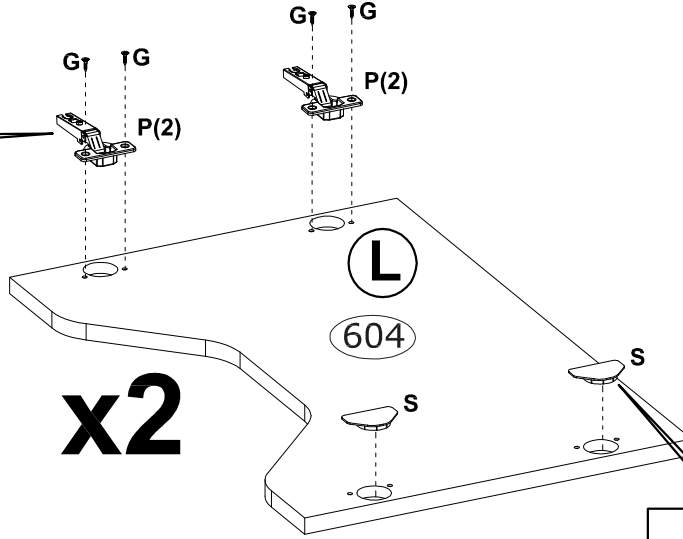
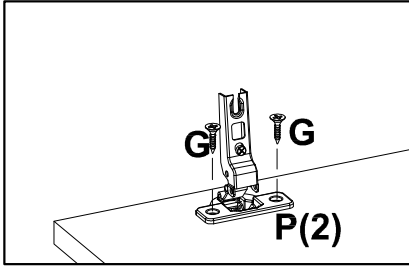
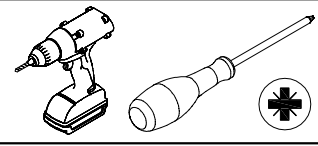

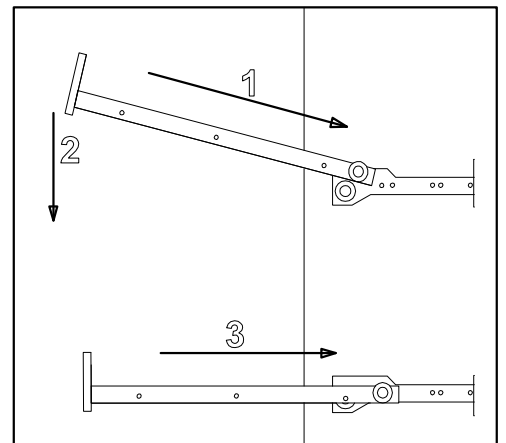
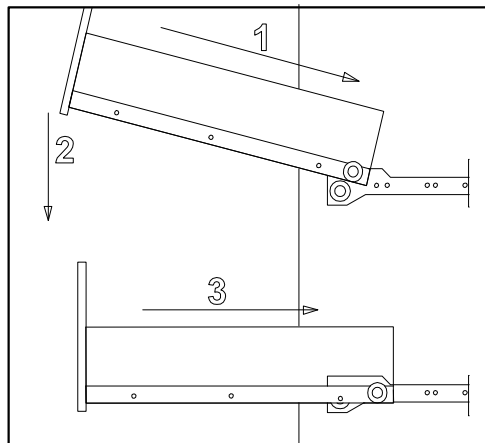
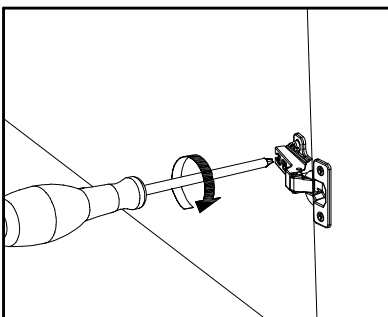
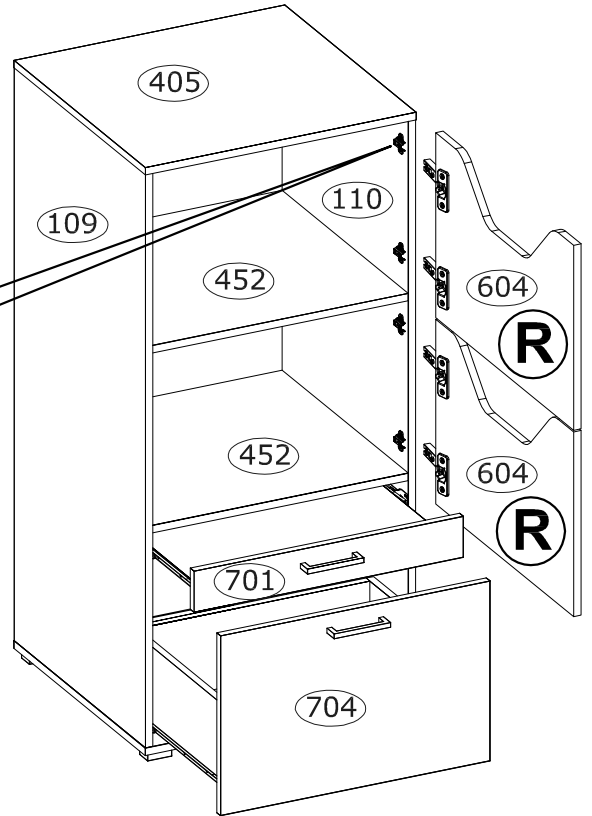
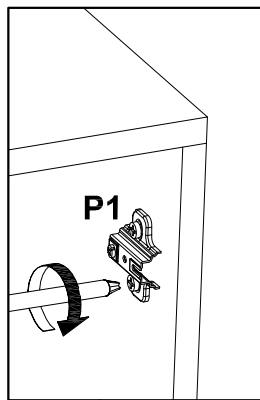
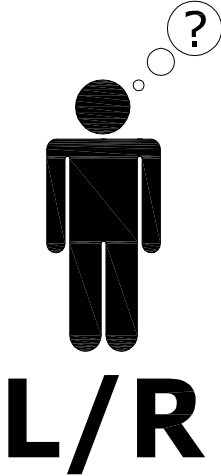
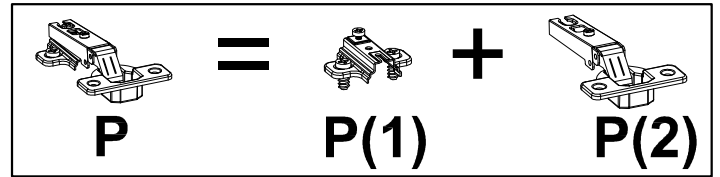
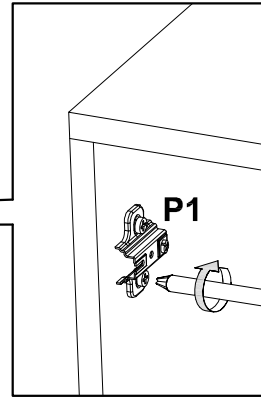
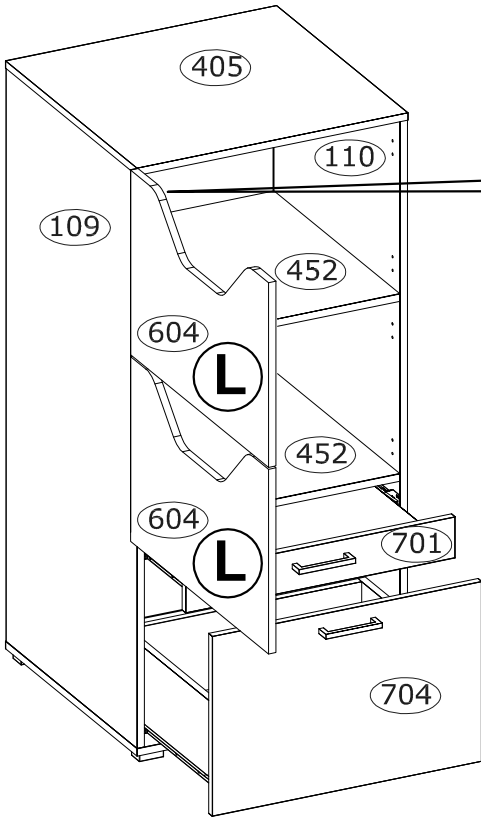
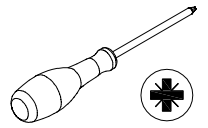

25

P Ø35 mm, KR0  
x4  
IN01640



26

<b>K</b> 75x15x32 mm  x2 71900	<b>G</b> Ø3,5x16 mm  x4 3918
--	---

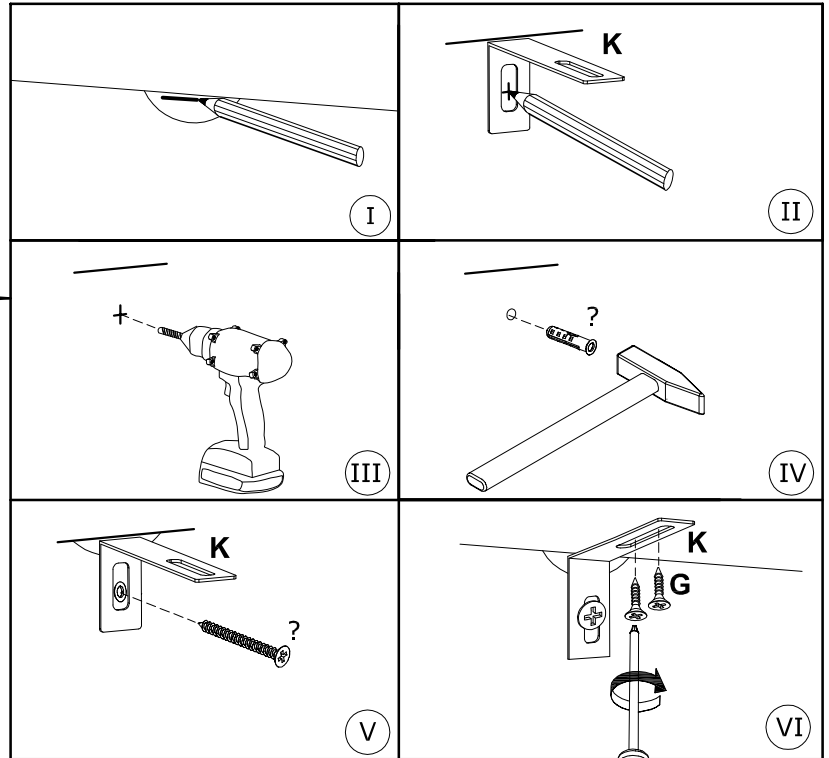
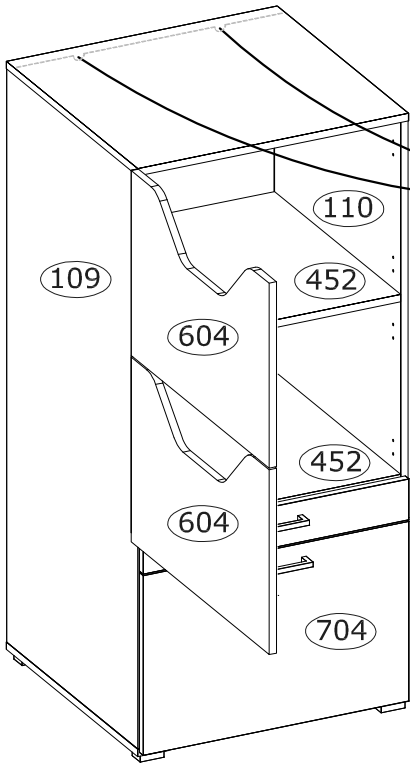
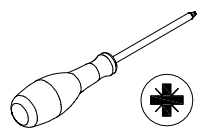

ACHTUNG! - ATTENTION! - ATTENTION! - ATTENZIONE! - LET OP! - UWAGA! - POZOR! - POZOR! - FIGYELEM! - ATENŢIE! - DİKKAT! - ВНИМАНИЕ! - ПРИМЕДБА! - NAPOMENA! - POZOR! - DĚMESÍO! - PIEZĪME! - MĀRKUS!

**D - ACHTUNG:** WARNUNG Umkippen zu vermeiden, muss dieses Produkt mit der mitgelieferten Wandhalterung verwendet werden.

**GB - WARNING:** WARNING In order to prevent overturning this product must be used with the wall attachment device provided.

**FR - REMARQUE:** AVERTISSEMENT Pour éviter le renversement, ce produit doit être utilisé avec le support de montage mural fourni.

**IT - NOTA:** AVVERTENZA Per evitare il ribaltamento, questo prodotto deve essere utilizzato con una staffa di montaggio a parete inclusa.

**NL - OPMERKING:** WAARSCHUWING Om kantelen te voorkomen, moet dit product worden gebruikt met de meegeleverde wandmontagebeugel.

**PL - UWAGA:** OSTRZEŻENIE Aby zapobiec przewróceniu, produkt ten musi być używany z dołączonym uchwytem do montażu ściennego.

**CZ - POZNÁMKA:** UPOZORNĚNÍ Aby se zabránilo převrácení, musí být tento výrobek používán s dodaným držákem pro montáž na stěnu.

**SK - OPOMBA:** OPOZORILO Da bi preprečili prevračanje, je treba ta izdelek uporabljati s priloženim nosilcem za pritrditev na steno.

**HU - MEGJEGYZÉS:** FIGYELMEZTETÉS A billenés megakadályozása érdekében ezt a terméket a mellékelt fali rögzítő konzollal kell használni.

**RO - NOTĂ:** AVERTISMENT Pentru a preveni răsturnarea, acest produs trebuie să

fie utilizat cu suportul de montare pe perete furnizat.

**TR - NOT:** UYARI Devrilmeyi önlemek için, bu ürün birlikte verilen duvara montaj braketi ile kullanılmalıdır.

**RU - ПРИМЕЧАНИЕ:** ПРЕДУПРЕЖДЕНИЕ Для предотвращения опрокидывания, этот продукт необходимо использовать с прикрепленным кронштейном для настенного монтажа.

**SRB - НАПОМЕНА:** УПОЗОРЕЊЕ Да бисте спречили превртање, овај производ мора да се користи са укљученом зидним заградом за монтажу.

**HR - NAPOMENA:** UPOZORENJE Da biste spriječili prevrtanje, ovaj se proizvod mora koristiti s priloženim zidnim nosačem.

**SL - POZNÁMKA:** UPOZORNENIE Aby sa zabránilo prevrátaniu, tento výrobok sa musí používať s dodanou nástennou montážnou konzolou.

**LT - PASTABA:** ĮSPĖJIMAS Kad šis gaminyš neapvirtų, jis turi būti naudojamas su pridedamu sieniniu laikikliu.

**LV - PIEZĪME:** BRĪDINĀJUMS Lai novērstu apgāšanos, šis izstrādājums jāizmanto kopā ar pievienoto sienas stiprinājuma kronšteinu.

**EE - MÄRKUS:** HOIATUS Kukkumise vältimiseks tuleb seda toodet kasutada koos kaasasoleva seinakinnitusklambriga.

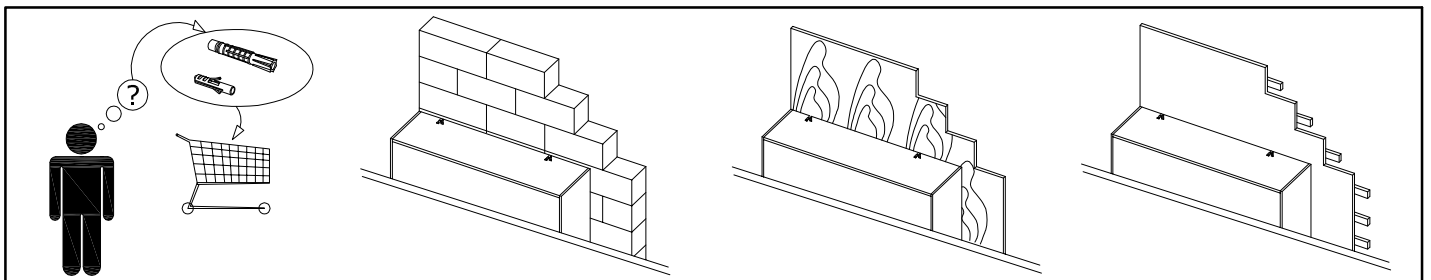

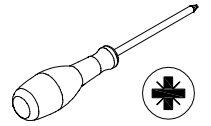

**Türen einstellen (Scharniere justieren)**  
**Adjusting the door (adjusting the hinges)**  
**Régler les portes (ajuster les charnières)**  
**Sistemare le porte (regolare le cerniere)**  
**Deuren instellen (scharnieren afstellen)**  
**Nastawić drzwi (wyregulować zawiasy)**  
**Vyrovňajte dvířka (seřid'te závěsy)**  
**Nastavenie dverí (nastavenie závesov)**  
**Állítsa be az ajtókat (állítsa be a zsanérokat)**

**Reglare uși (ajustare balamale)**  
**Kapıların ayarlanması (menteşelerin seviye ayarı)**  
**Регулировка дверей (регулировка шарнира)**  
**Поставите врата (подесите шарке)**  
**Postavite vrata (podesite šarke)**  
**Nastavenie dverí (nastavenie závesov)**  
**Sureguliuokite duris (sureguliuokite vyrius)**  
**Pielāgojiet durvis (noregulējiet eņģes)**  
**Reguleeri uks (reguleeri hinged)**

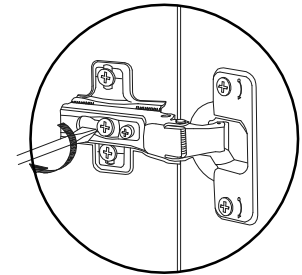
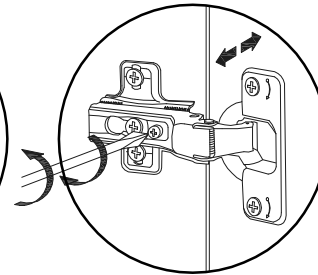
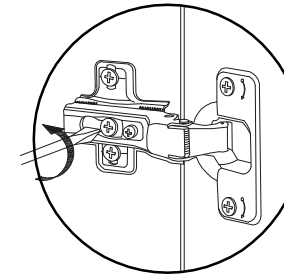
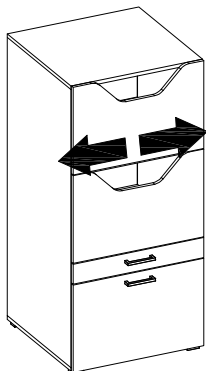
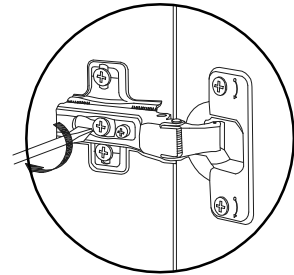
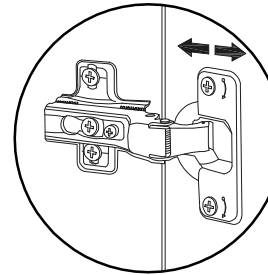
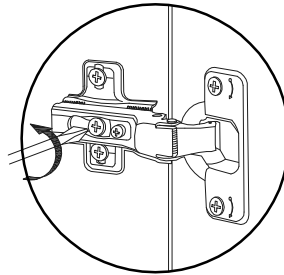
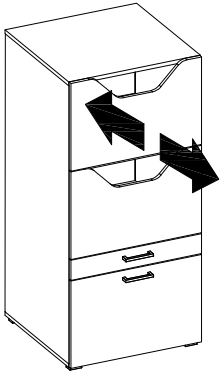
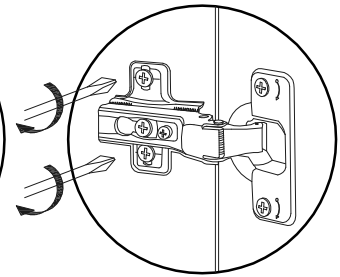
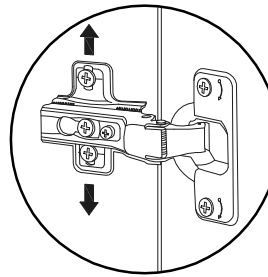
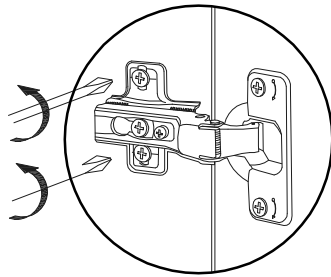
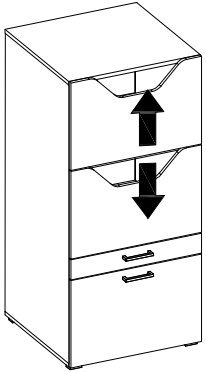

- D** Sicherheits- und Pflegehinweise
- FR** Conseils de sécurité et d'entretien
- NL** Veiligheids- en onderhoudstips
- CZ** Tipy pro bezpečnost a údržbu
- HU** Biztonsági és karbantartási tanácsok
- TR** Güvenlik ve bakım ipuçları
- ES** Instruções de segurança e manutenção
- SRB** Савети за безбедност и одржавање
- SL** Nasveti za varnost in vzdrževanje
- LV** Drošības un apkopes padomi

- GB** Safety and maintenance tips
- IT** Consigli per la sicurezza e la manutenzione
- PL** Wskazówki dotyczące bezpieczeństwa i konserwacji
- SK** Tipy na bezpečnosť a údržbu
- RO** Sfaturi de siguranță și întreținere
- RU** Советы по безопасности и обслуживанию
- PT** Instruções de segurança e manutenção
- HR** Savjeti za sigurnost i održavanje
- LT** Saugos ir priežiūros patarimai
- EE** Ohutus- ja hooldusnõuanded

