

PL Instrukcja montażu
CZ Instrukce k instalaci
D Montageanleitung
GB Assembly instruction
F Midel d'emploi
HU Szerelési útmutató
I Istruzione di montaggio
NL Handleiding voor de montage
RU Инструкция по установке
RO Instructiuni de instalare
SK Návod na inštaláciu
TR Montaj talimati
SE Montering instruktion
SLO Navodila za namestitev
HR Upute za sastavljanje

MONTÁŽNÍ/MONTÁŽNY NÁVOD LAIMA

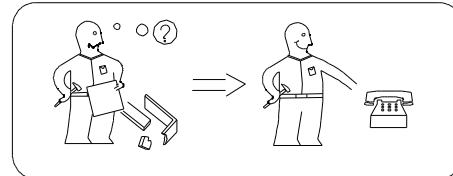

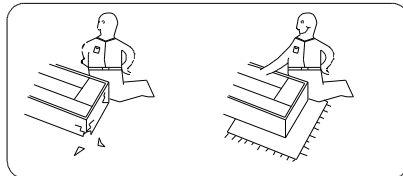
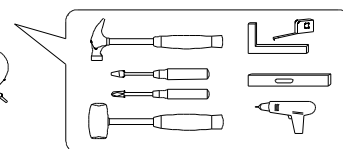
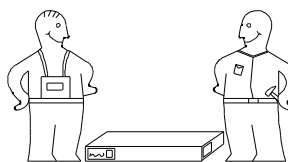

! Uwaga . Upozornini. Achtung . Attention . Caution . Firyelem . Attenzione . Opgelet . внимание . Atentie . Upozornenie . Dikkat . Uppmärksamhet . Uppmärksamhet . Pozor . Pažnja **!**

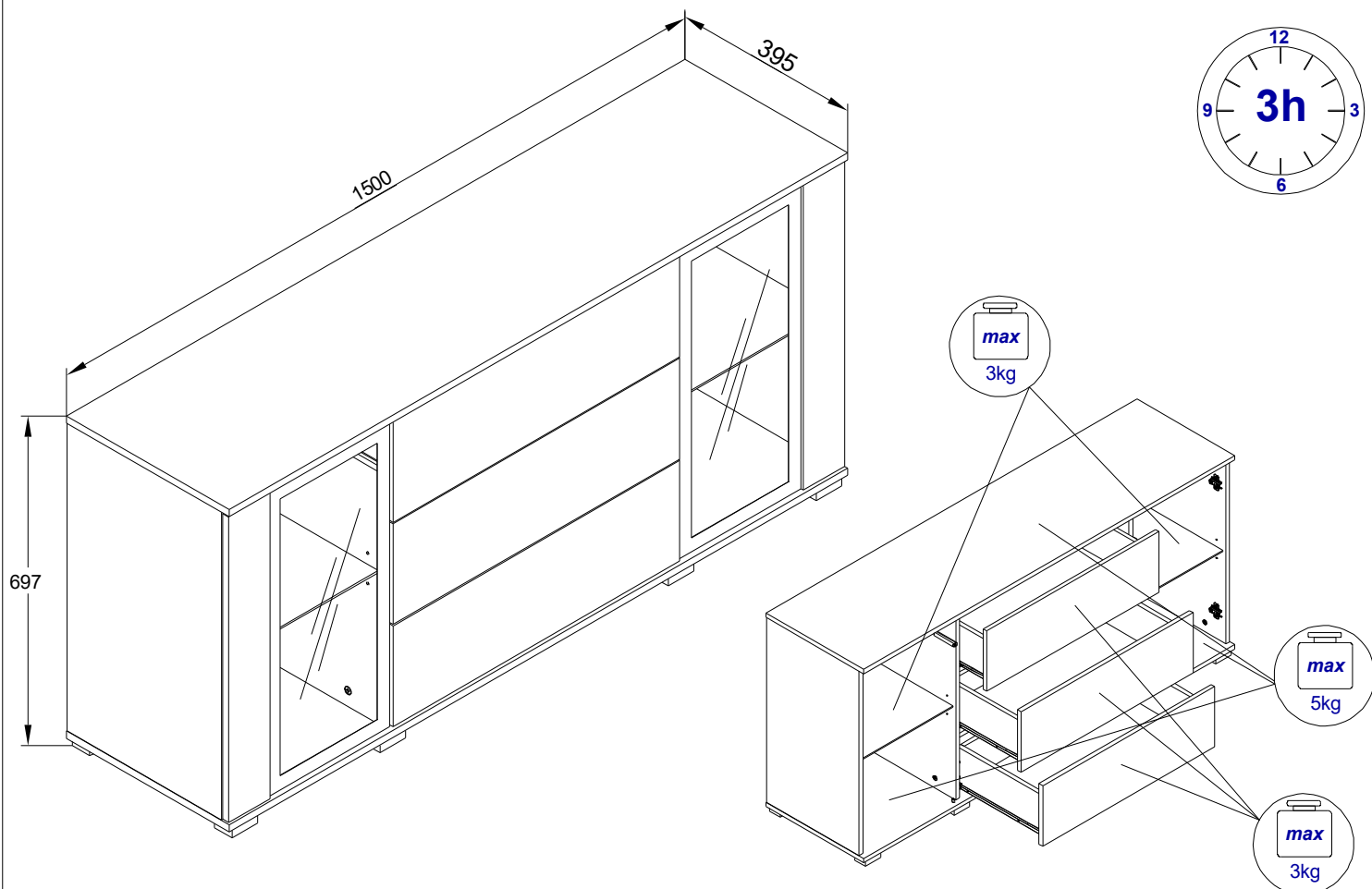



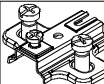

PL	Czyszczenie należy wykonywać wyłącznie za pomocą ściereczki lekko nawilżonego ręcznika. nie stosować środków czyszczących do szorowania.	I	La pulizia deve essere eseguita solo con un panno e un asciugamano leggermente inumidito. non utilizzare agenti abrasivi.
CZ	Čištění i by se mělo provádět pouze hadříkem a mírně navlhčeným ručníkem. nepoužívejte abrazivní prostředky.	NL	Reinig alleen met een stofdoek of lichtjes met een vochtige doek. Gebruik geen schurende of bijtende poetsmiddelen.
D	Bitte nur mit einem Staubtuch oder leicht feuchtem Lappen reinigen. Keine scheuernden Putzmittel verwenden.	RU	Чистку следует производить только тряпкой, слегка смоченной полотенцем. не используйте чистящие средства.
GB	Please only clean with a duster or a damp cloth. Do not use any abrasive cleaners.	RO	Curatare trebuie efectuată numai cu o carpa sau cu un prosop ușor umezit. Nu utilizați agenți de curatare abrazivi.
F	Le nettoyage doit être effectué uniquement avec un chiffon, une serviette légèrement humidifiée. n'utilisez pas d'agents à récurer.	SK	Čistenie by sa malo uskutočňovať iba pomocou handričky a mierne navlhčeného uteráka. nepoužívajte drsné prostriedky.
HU	A tisztítást csak ruhával, enyhén megnedvesített törülközővel szabad elvégezni. ne használjon tisztítószert a súroláshoz.	TR	Temizlik sadece bezle, hafifçe nemlendirilmiş havluyula yapılmalıdır. ovma maddeleri kullanmayın.
SE	Torka rent med en fuktig trasa. Använd endast vatten eller ett mild rengöringsmedel. Torka torrt med en ren trasa.	SLO	Obrišite z vlažno krpo. Uporabljajte le vodo ali blag detergent. Posušite s čisto krpo.
HR	Očistite vlažnom krpom. Upotrijebite samo vodu ili blagi deterđent. Posušite čistom krpom.		



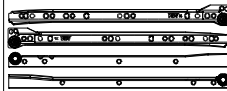







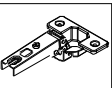

I

			
S3	B	D	LD
x4	x8	x8	x4











II

						
6,3x13	F2	S3	D	A	PS	B
x3 PR350	x12	x4	x8	x4	x2	x8

III-XII



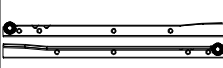

											
B	D	4x16 H8	ZD1	4x22 H14	M	S3	A	X3	I	PS	X3
x4	x4	x8	x4	x16	x8	x2	x16	x16	x22	x3	x2

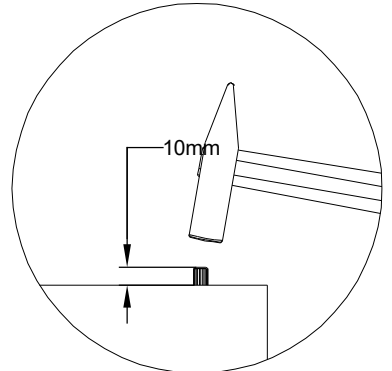
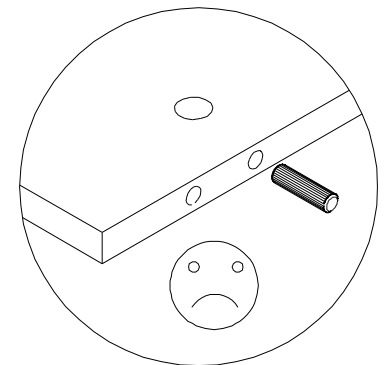
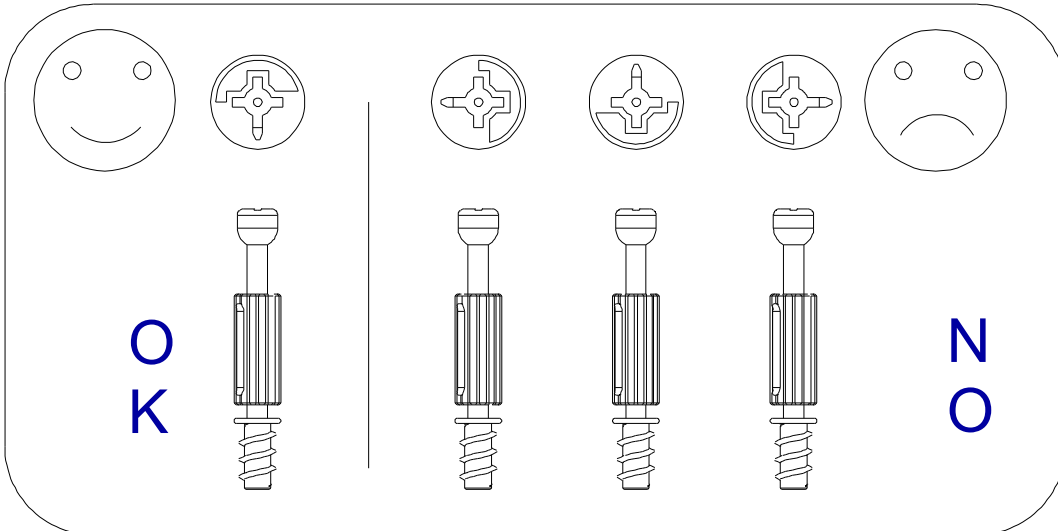
XIII-XV

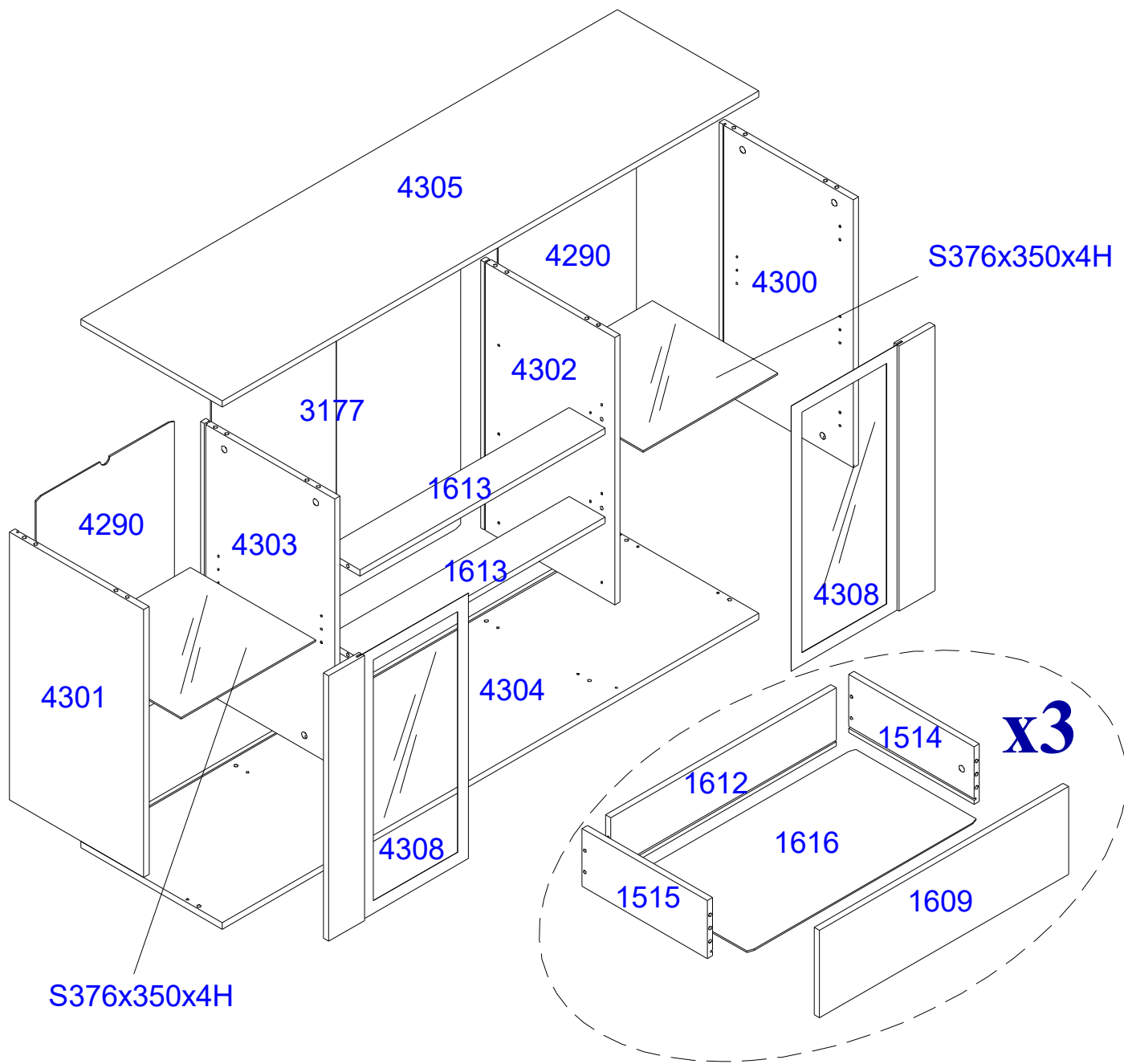
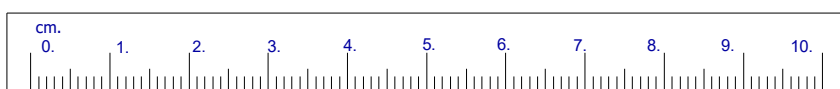
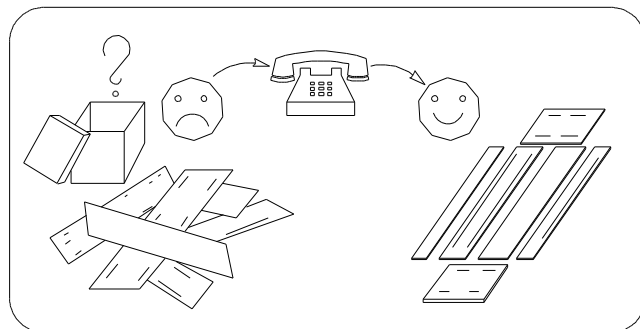
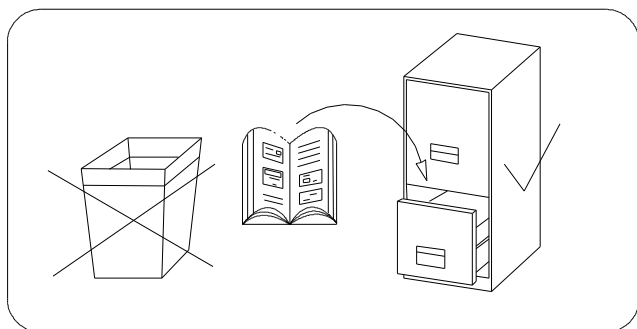





										
WS	7x50 O	U	3x20 H2	3x13 H4	D	B	A	1/2 PR 350	KM	X3
x3	x12	x1	x12	x6	x12	x6	x6	x3	x2	x6

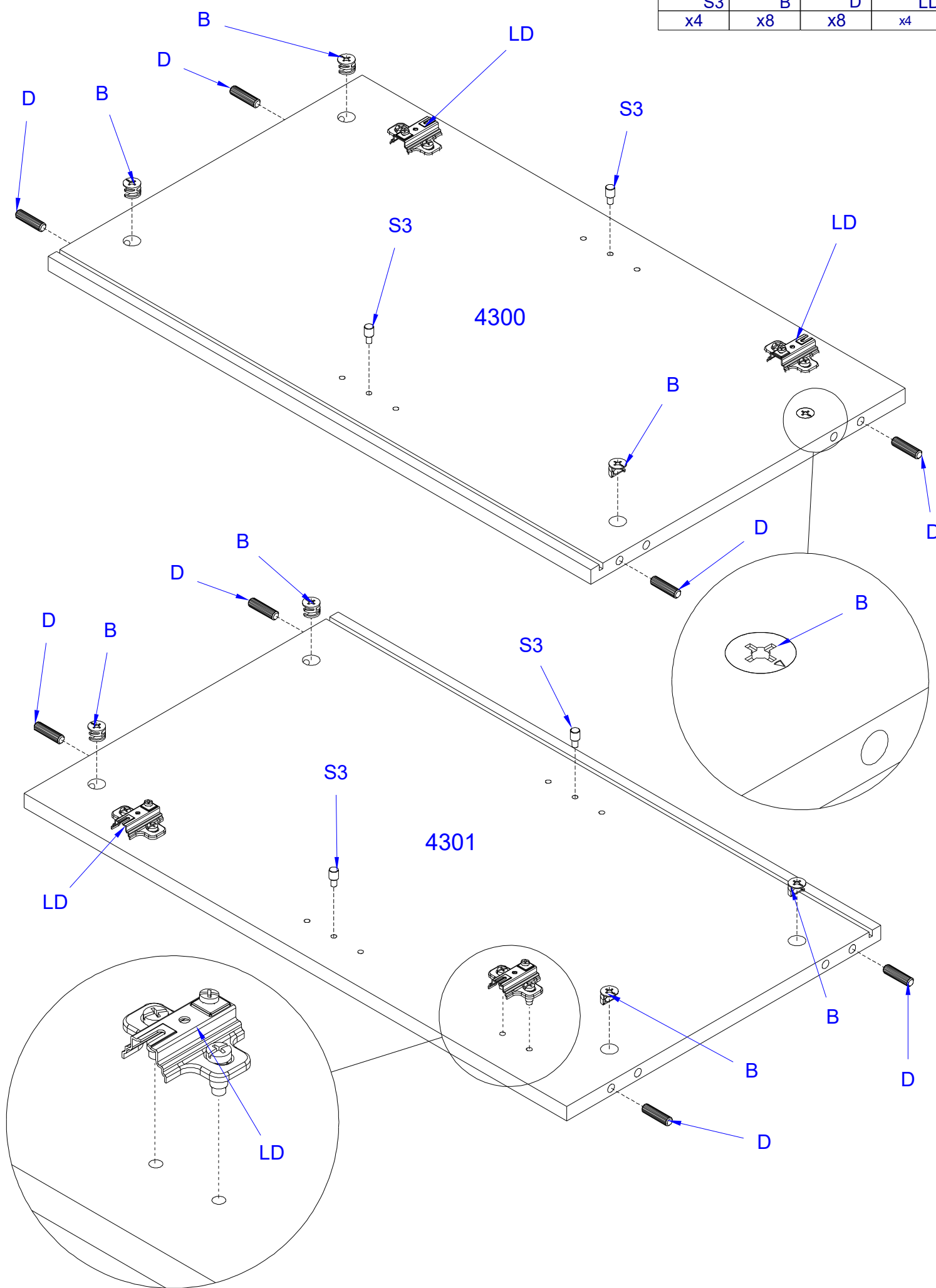





			
S3	B	D	LD
x4	x8	x8	x4

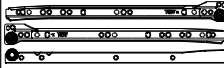

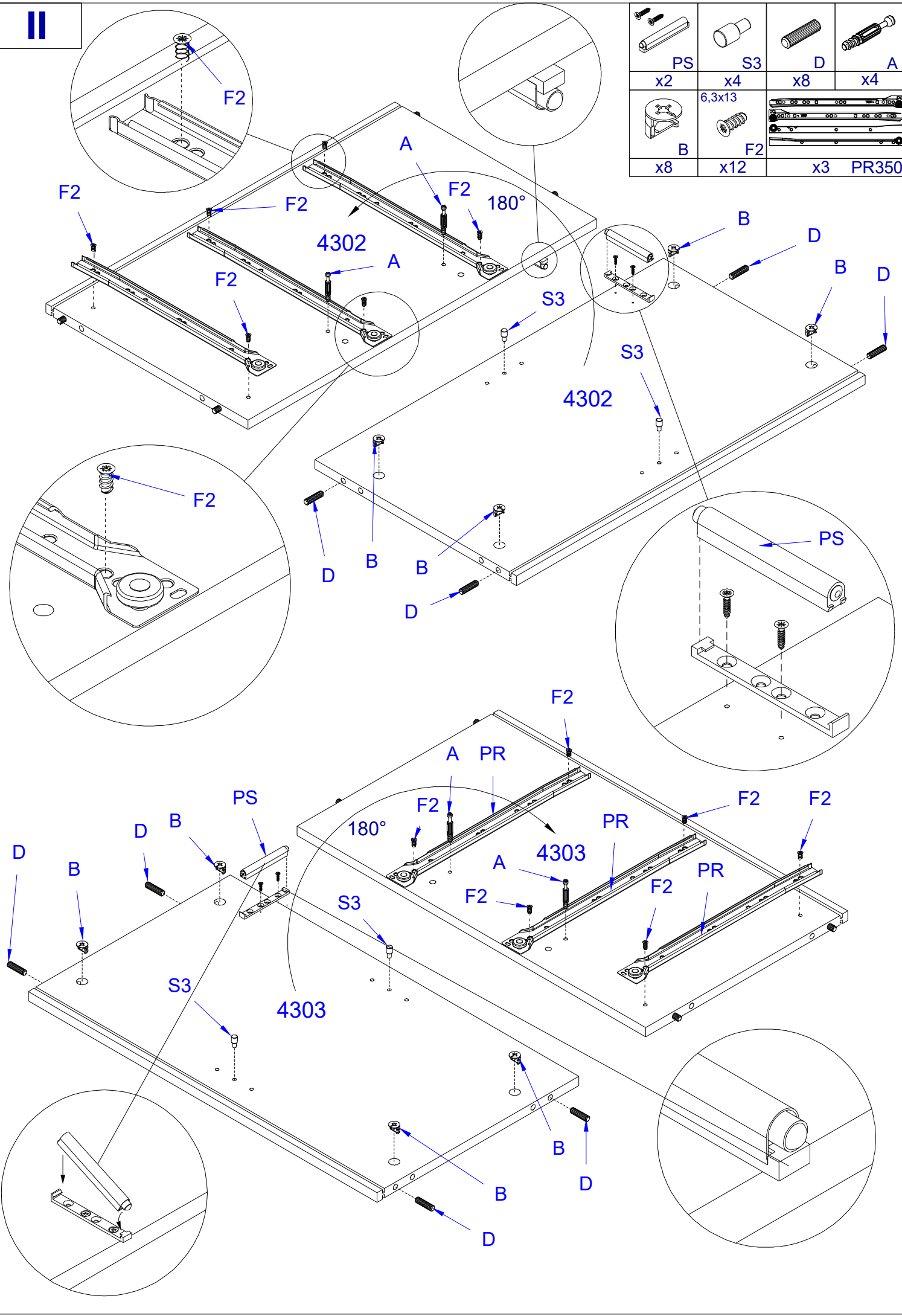
			
PS	S3	D	A
x2	x4	x8	x4
			
B	F2	PR350	
x8	x12	x3	





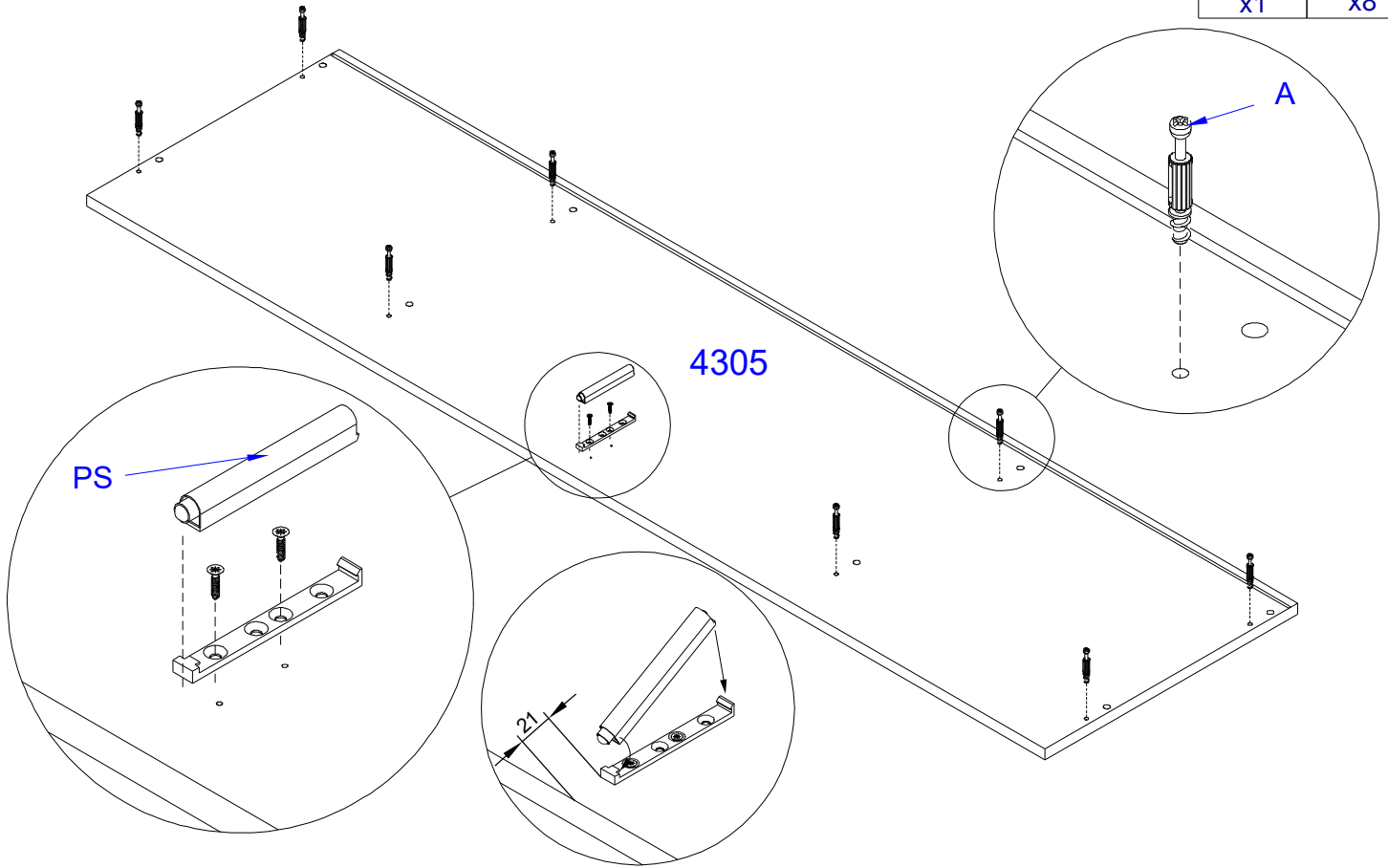

	
PS	A
x1	x8





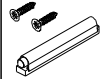

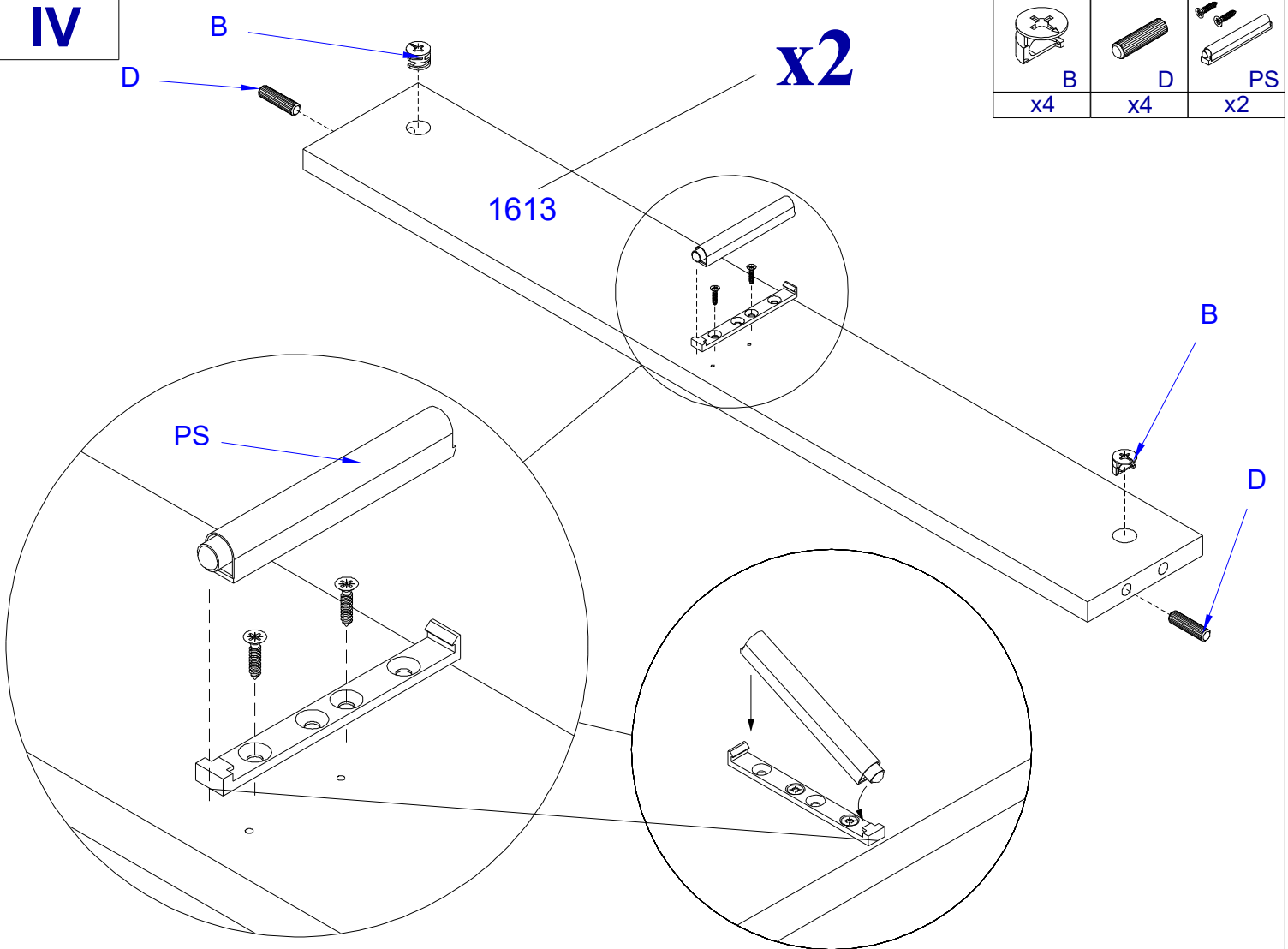
IV

		
B	D	PS
x4	x4	x2



V

4x22 			
H14 x16	M x8	S3 x2	A x8

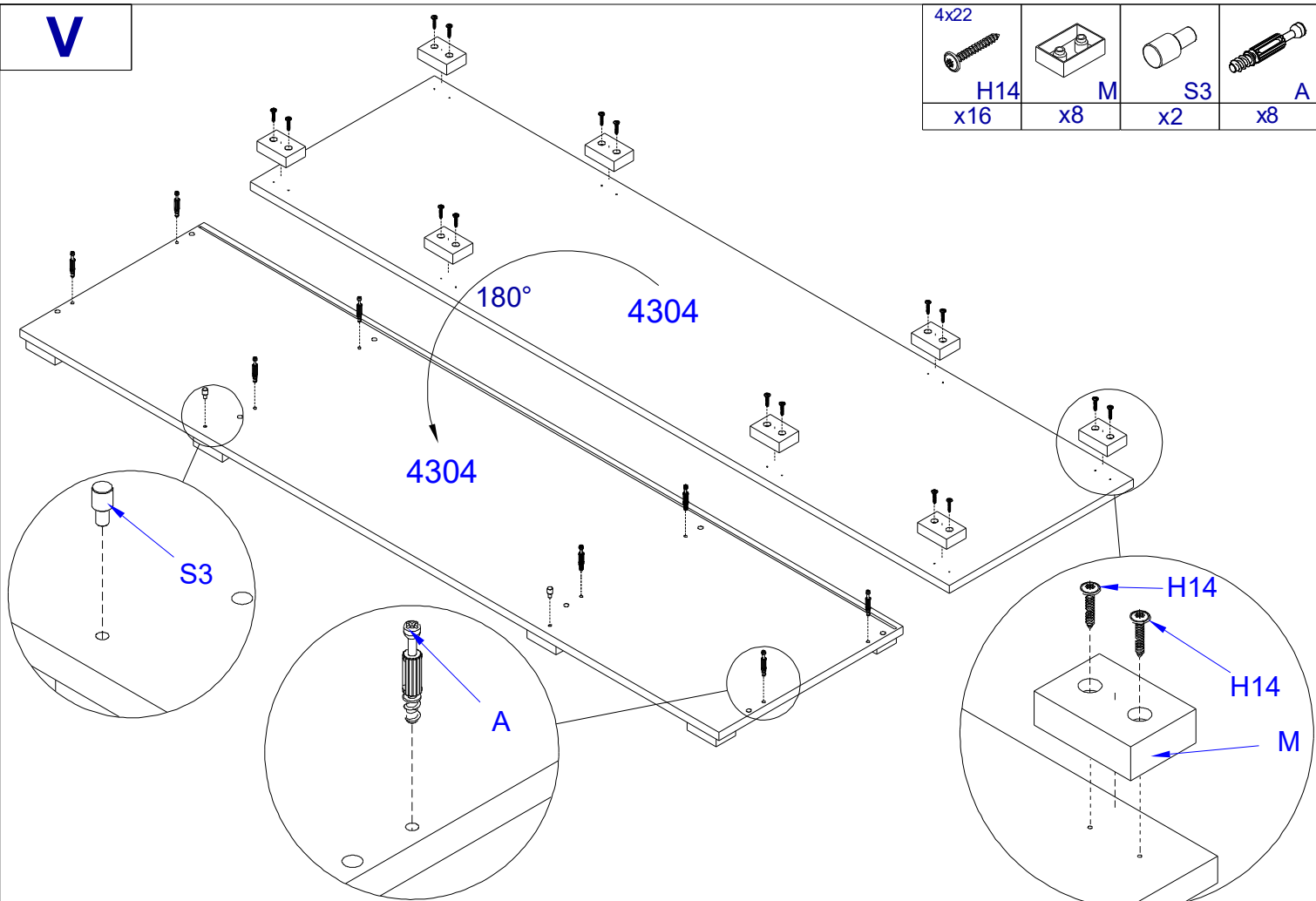
**VI**

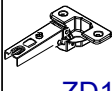
4x16 	
H8 x8	ZD1 x4

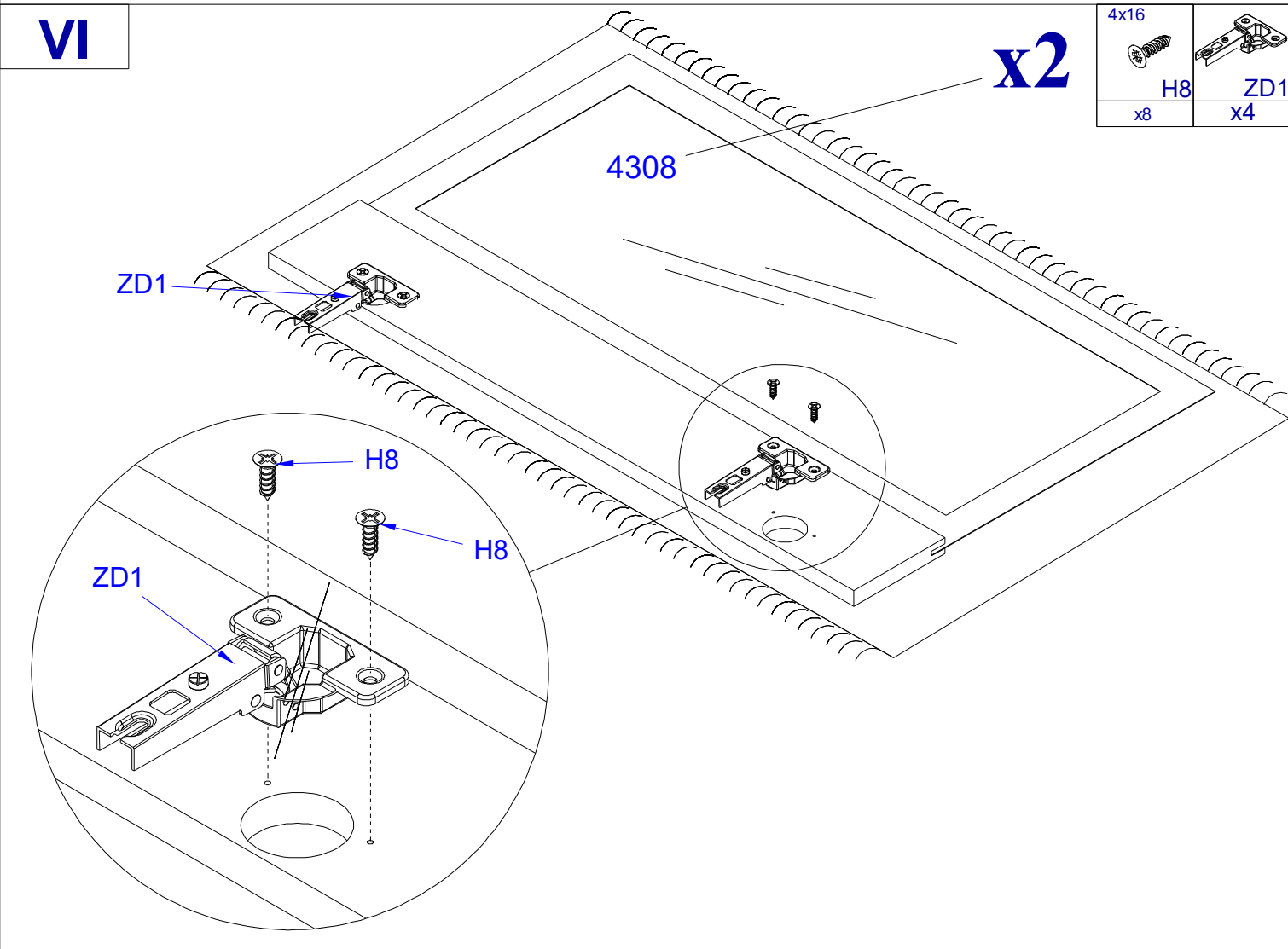

VII

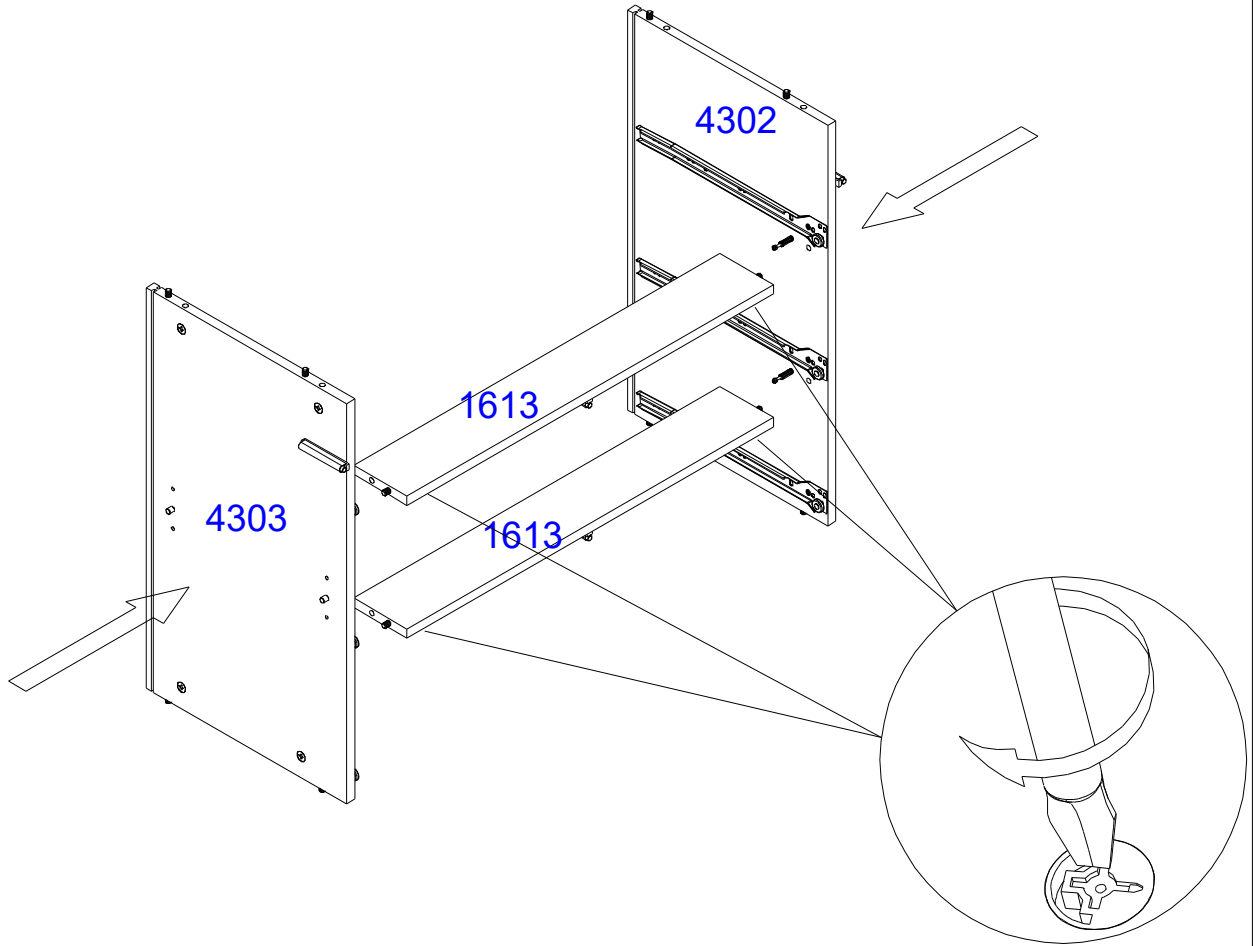

VIII

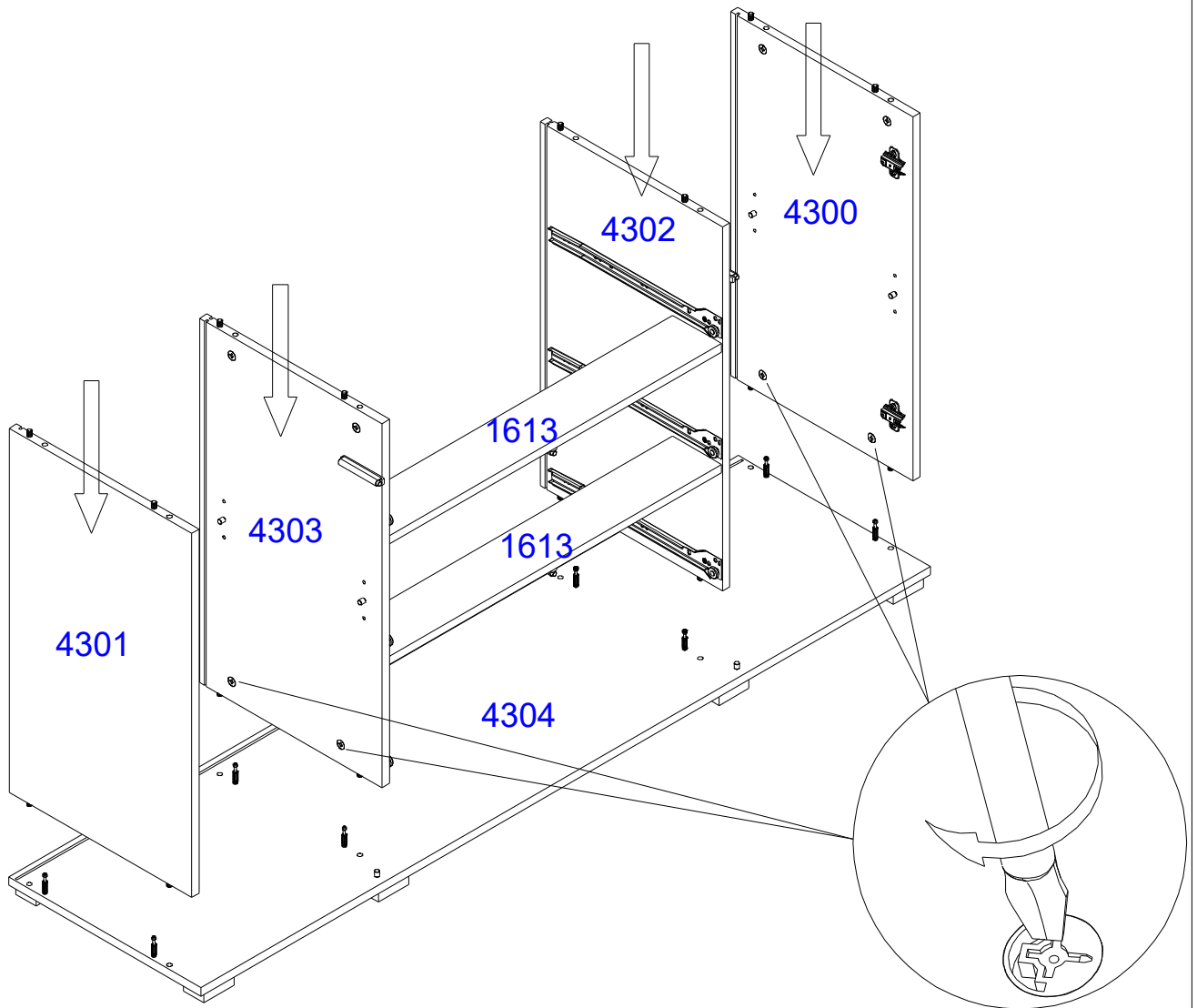

IX

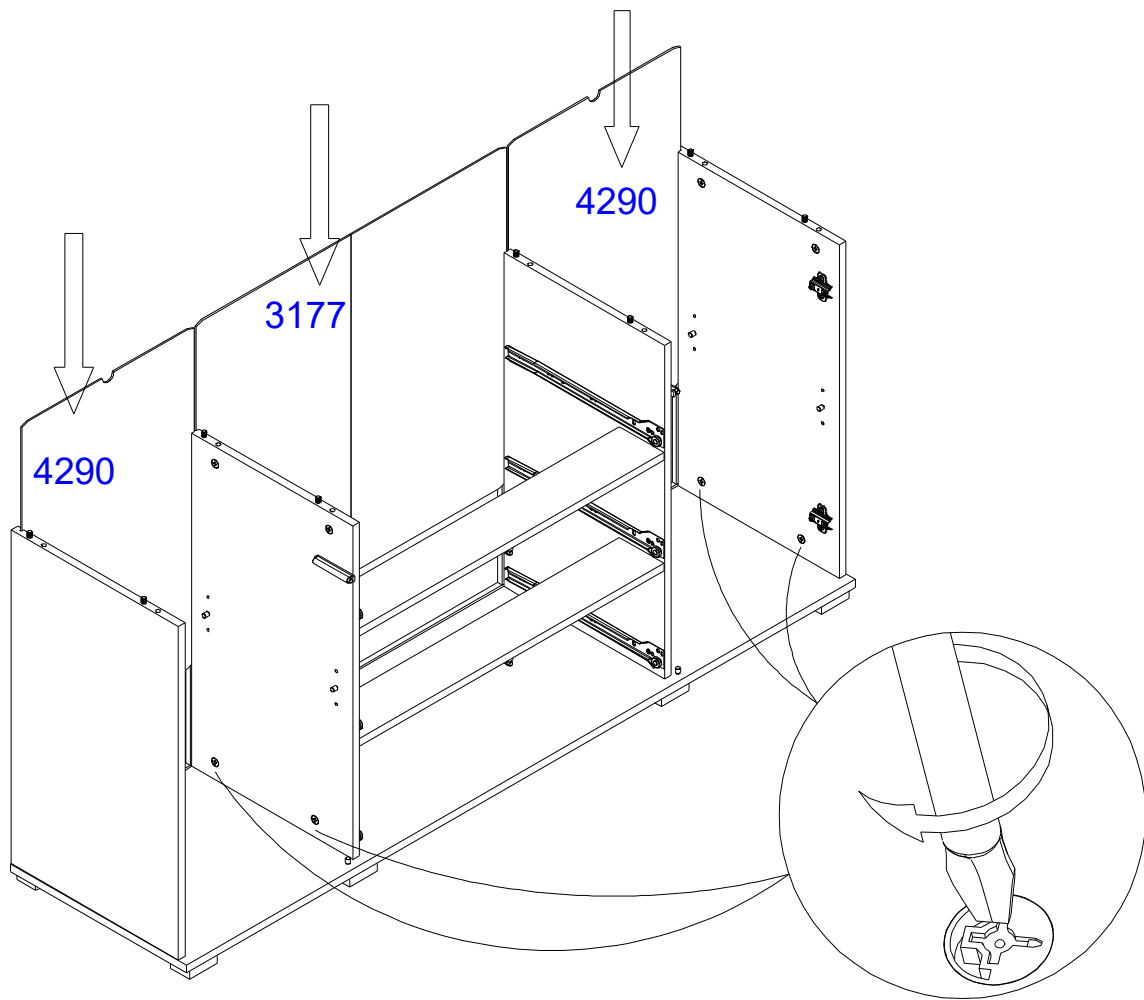

X

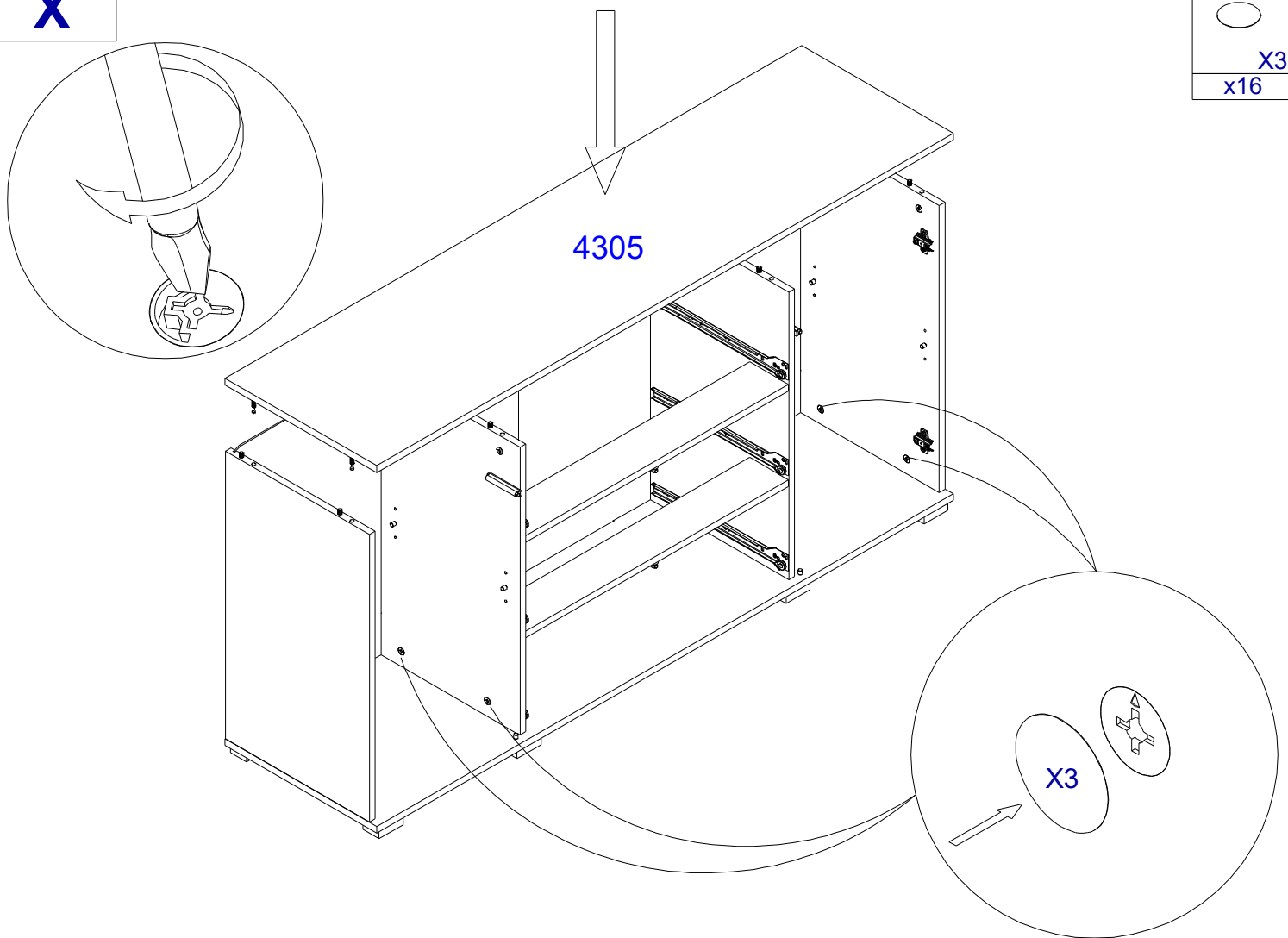

XI



x22

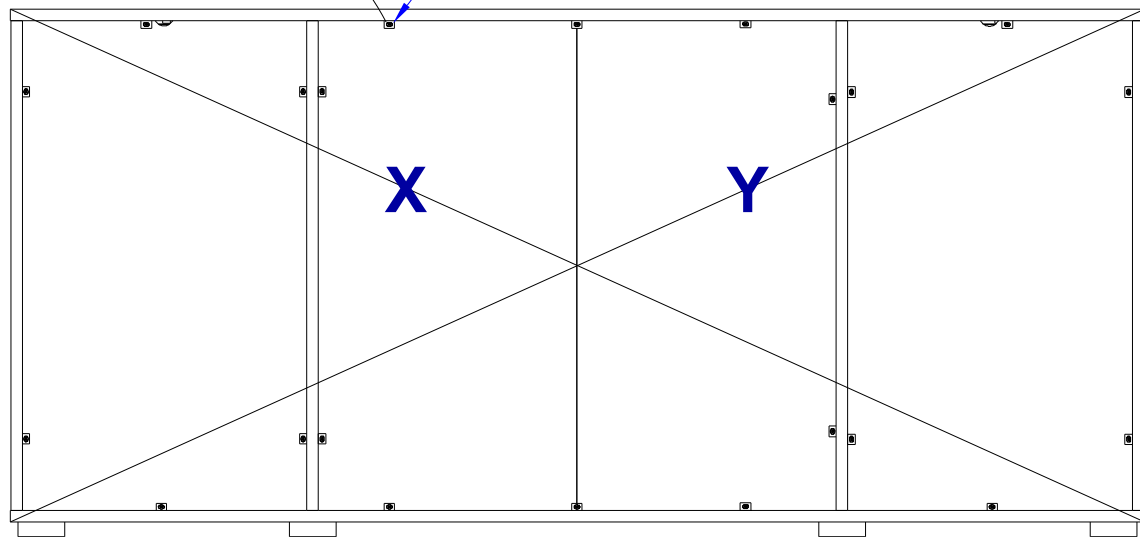
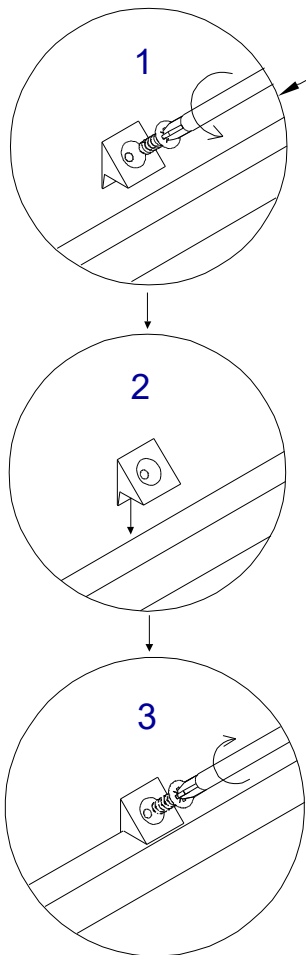

$$X=Y$$

XII









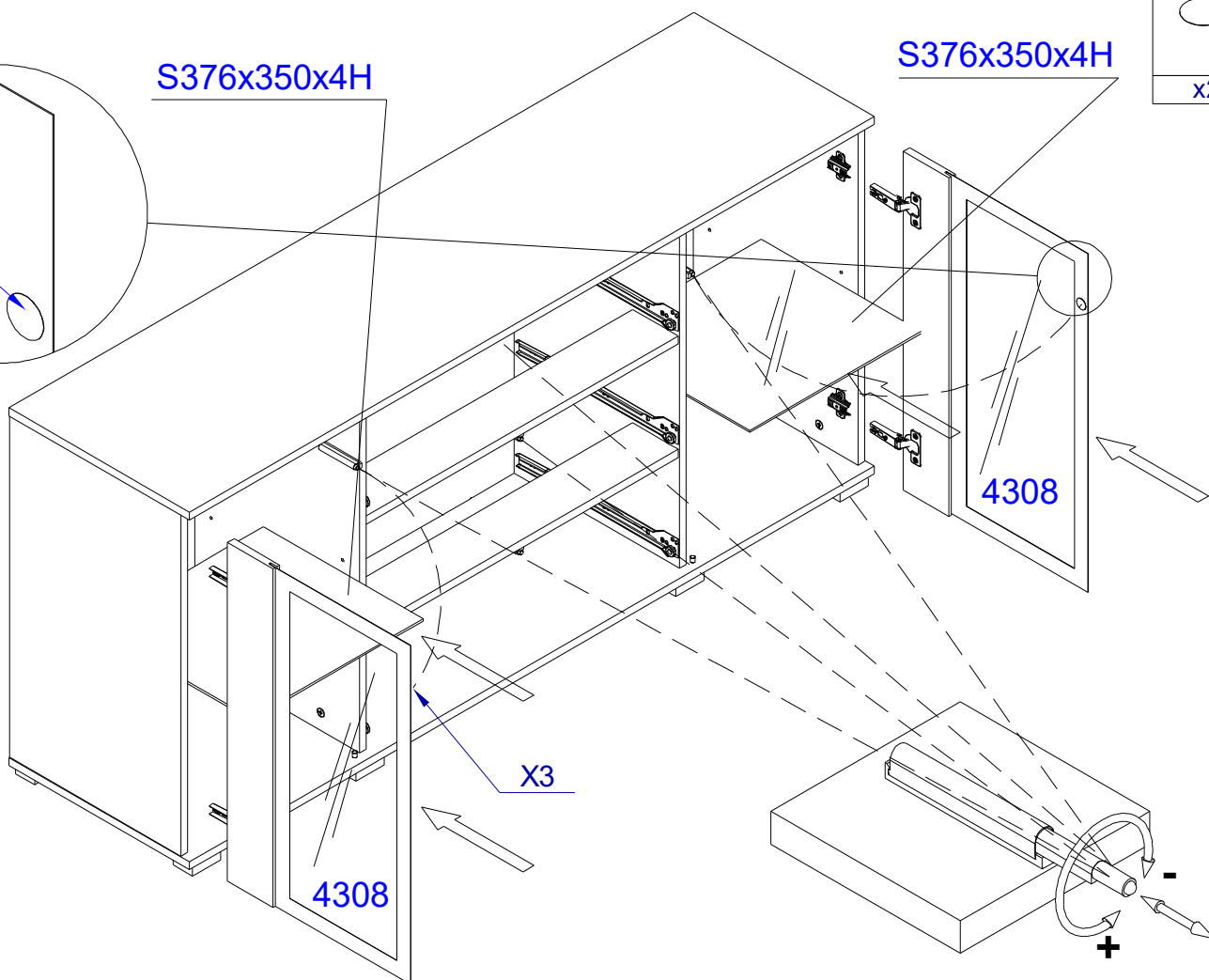
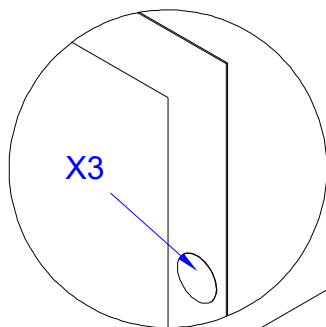

x3
x2

S376x350x4H

S376x350x4H



XIII

					
x1	x6	x12	x12	x6	x6
					
		x12	x6	x3	

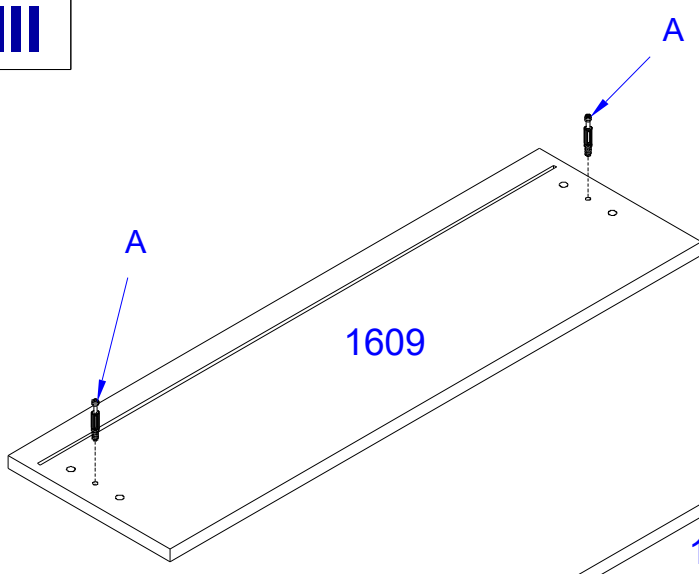

1609

A

A

3x

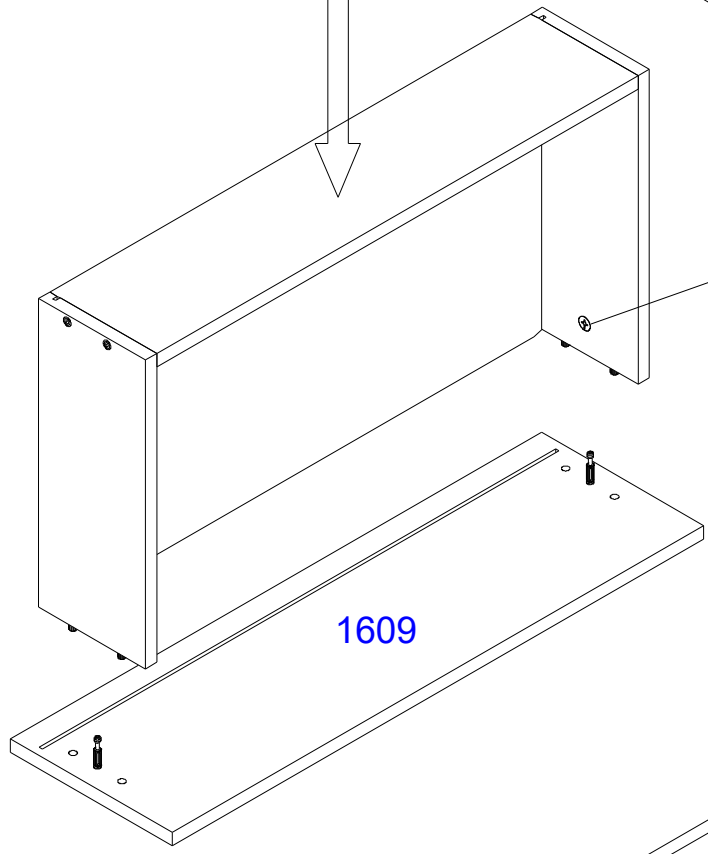

1612

1616

1515

1514

O

O

B

D

D

D

D

O

O

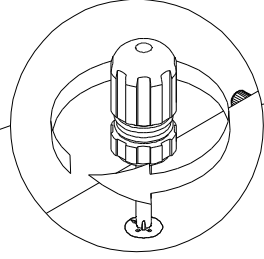

X3

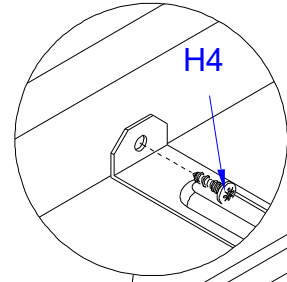

H4

H2

1/2 PR 350

H2

WS

1/2 PR 350

H4

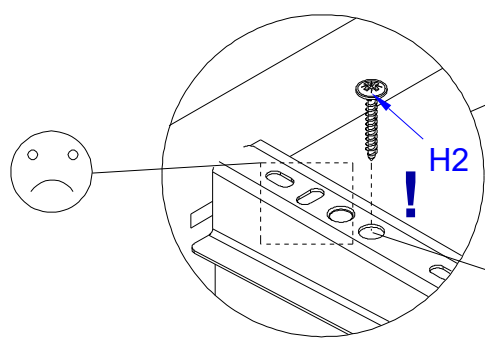

H2

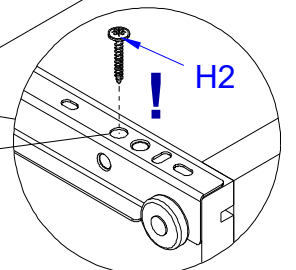

H2

XIV

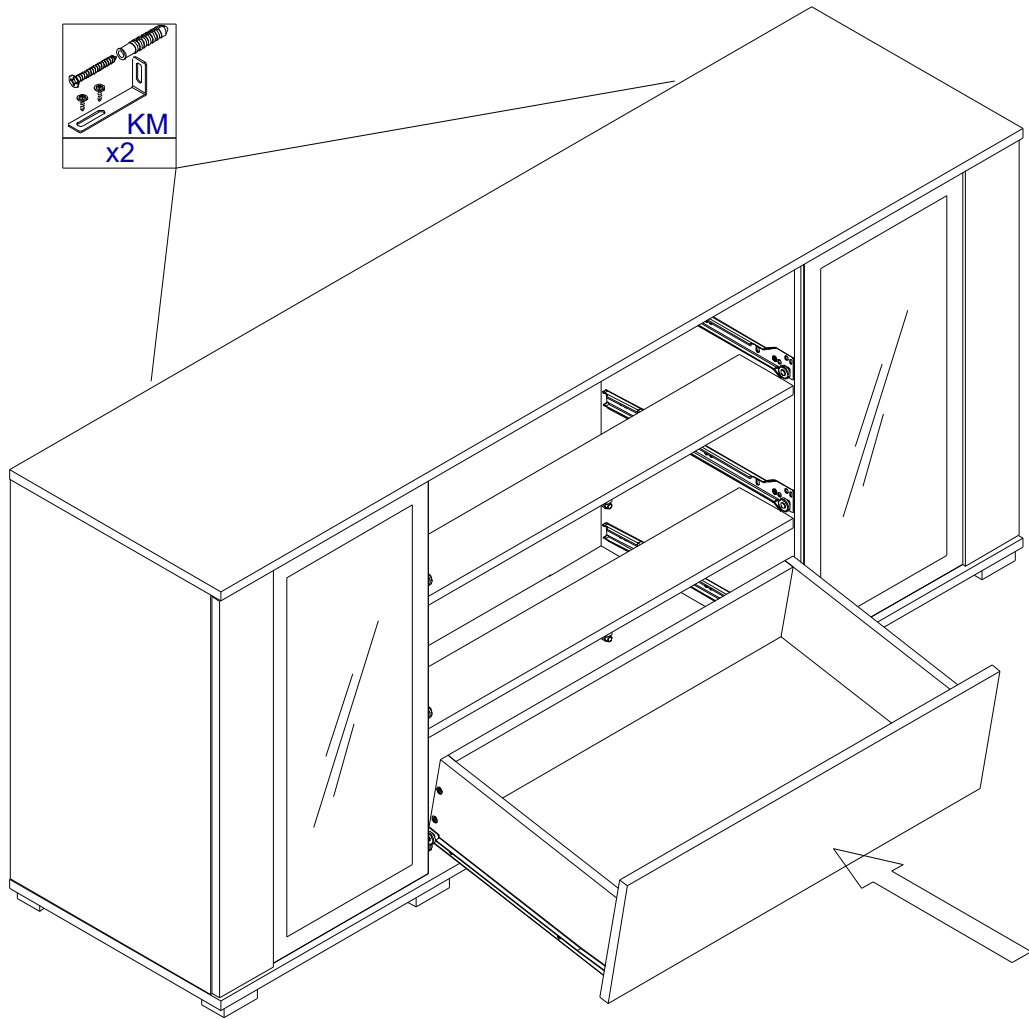
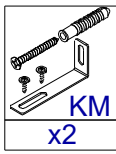

XV

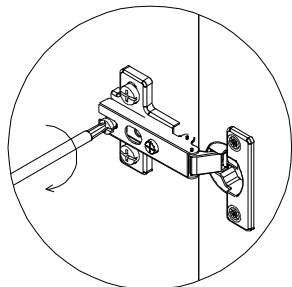
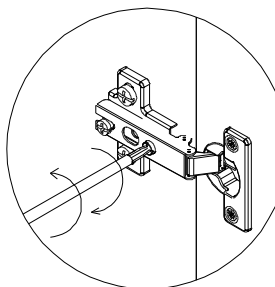
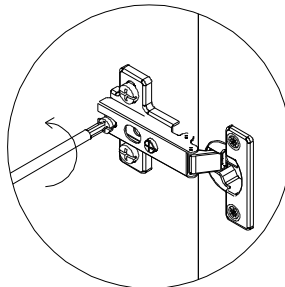
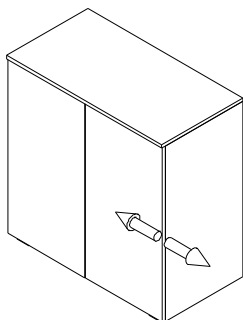
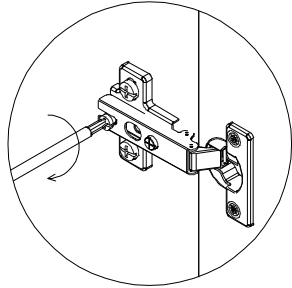
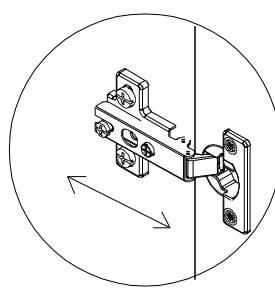
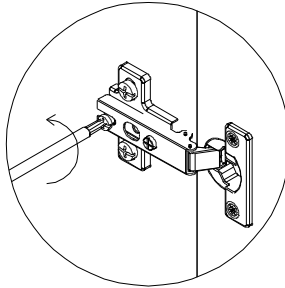
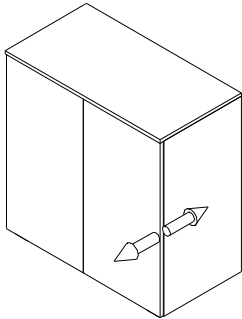
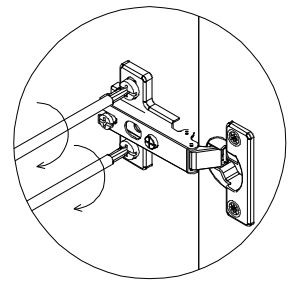
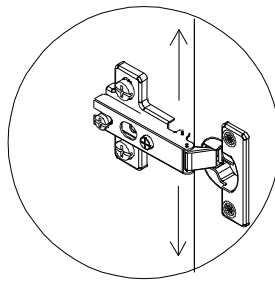
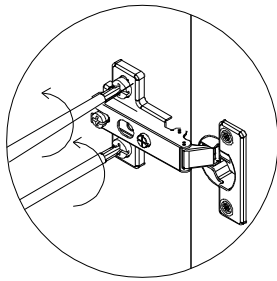
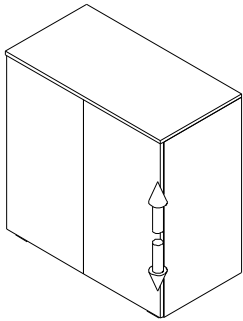

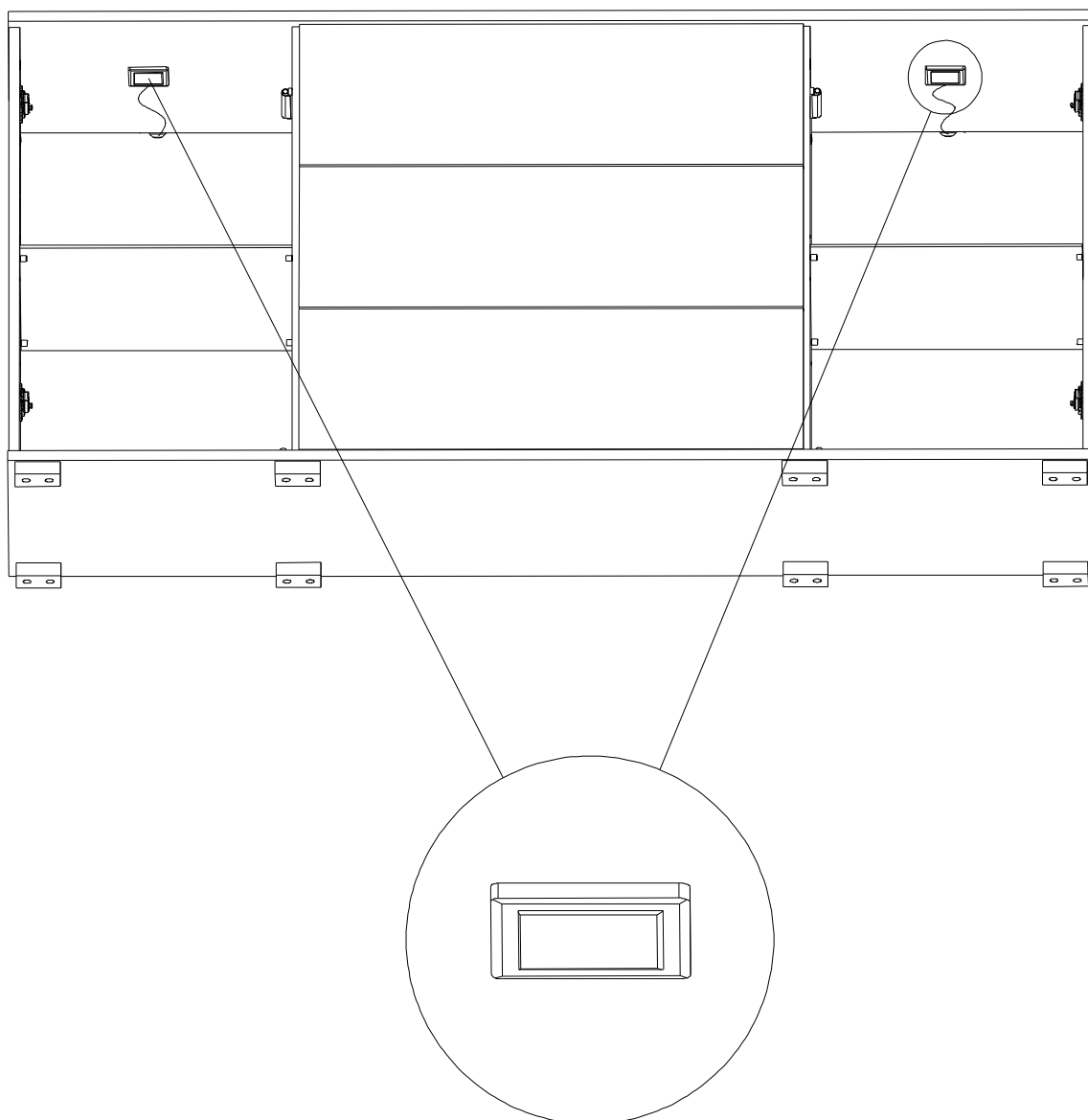

PL Uwaga: Punkt mocowania opcjonalnego oświetlenia	RO Notă: Punct de atașare pentru iluminatul opțional
CZ Poznámka: Připojovací bod pro volitelné osvětlení	SK Poznámka: Pripojovací bod pre voliteľné osvetlenie
D Hinweis: Befestigungspunkt für optionale Beleuchtung	TR Not: İsteğe bağlı aydınlatma için bağlantı noktası
GB Note: Attachment point for optional lighting	SE Obs: Monteringspunkt för valfri belysning
F Remarque: point de fixation pour éclairage optionnel	SLO Opomba: Montažna točka za dodatno razsvetljavo
HU Megjegyzés: Az opcionális világítás rögzítési pontja	HR Napomena: Montažna točka za opcijnsko osvjetljenje
I Nota: punto di attacco per illuminazione opzionale	RU Примечание: точка крепления для дополнительного освещения
NL Opmerking: bevestigingspunt voor optionele verlichting	

1

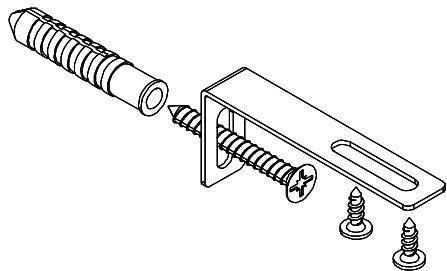

Uwaga . Upozornini. Achtung . Attention . Caution Firyelem . Attenzione . Opgelet . ВНИМАНИЕ . Atentie . Upozornenie . Dikkat . Uppmärksamhet . Uppmärksamhet . Pozor . Pažnja

PL	Mocowanie do ściany jest jednocześnie zabezpieczeniem przed przewróceniem - koniecznie zamontować! Do niektórych rodzajów ścian koniecznie zastosować specjalne kołki mocujące.	I	Il fissaggio alla parete serve da protezione anti-ribaltamento - attaccarla assolutamente! Per alcune strutture di parete può essere necessario un tassello speciale!
CZ	Montáž na stěnu slouží jako ochrana proti převrnutí - bezpodmínečně umístěte! U některých typů stěn může být zapotřebí speciální hmoždinka!	NL	Bevestiging aan de muur dient als kantelbescherming - zeker en vast bevestigen! Bij enkele muurtypes is een speciale plug misschien vereist!
D	Wandbefestigung dient als Kippschutz - unbedingt anbringen! Bei einigen Wandtypen kann ein Spezialdübel erforderlich sein!	RU	Крепление к стене также является защитой от опрокидывания - обязательно установите! Для некоторых типов стен необходимо использовать специальные крепежные штифты.
GB	The wall fastening serves to prevent tipping - be absolutely sure to mount it! For certain wall types, a special wall plug may be necessary!	RO	Sistemul de fixare la perete serve și ca protecție la răsturnare - de montat obligatoriu! Pentru unele tipuri de pereți este posibil să fie necesar un diblu special!
F	La fixation murale sert de protection contre le basculement - à installer impérativement ! Pour certains types de murs il faut des chevilles spéciales !	SK	Upevnenie na stenu slúži ako ochrana proti prevráteniu - bezpodmienečne použite! Pre niektoré druhy stien môže byť potrebná špeciálna hmoždinka!
HU	A termékét a falhoz keletlenül kell rögzíteni, kőülönben az felborulhat! Egyes fal típusoknál speciális tiplit kell használni!	TR	Duvardaki sabitleme, devrilmeye karşı, bir emniyet tedbiridir ve mutlaka monte edilmelidir! Bazı duvar tiplerinde bunun için özel bir dübel gereklidir!
SE	Att fästa den på väggen är också ett skydd mot att välta - se till att installera det! För vissa typer av väggar är det nödvändigt att använda speciella monteringsstift.	SLO	Prifrditev na steno je tudi zaščita pred prevrnitvijo - obvezno jo namestite! Za nekatere vrste sten je treba uporabiti posebne prifrdilne zatiče.
HR	Pričvršćivanje na zid je ujedno i zaštita od prevrtanja - obavezno ga postavite! Za neke vrste zidova potrebno je koristiti posebne pri čvršćne igle.		

2a

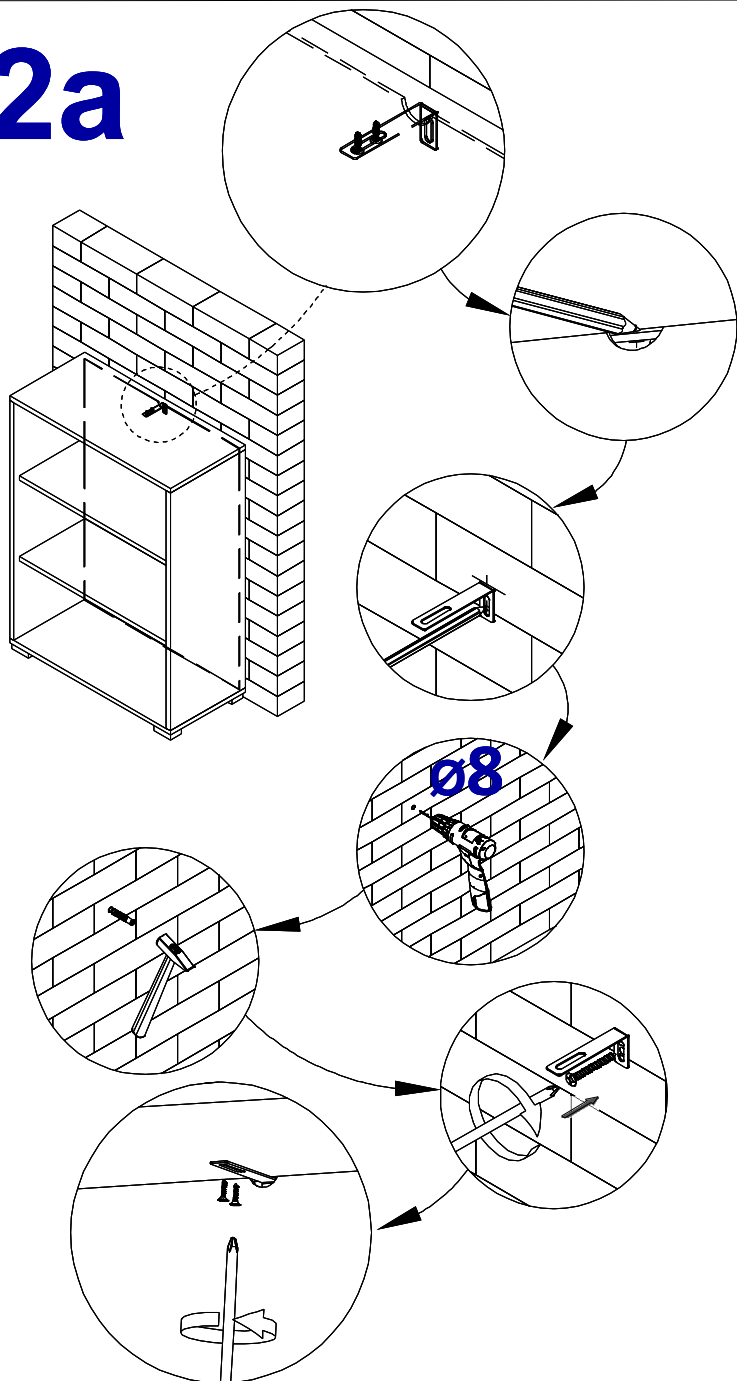

2b

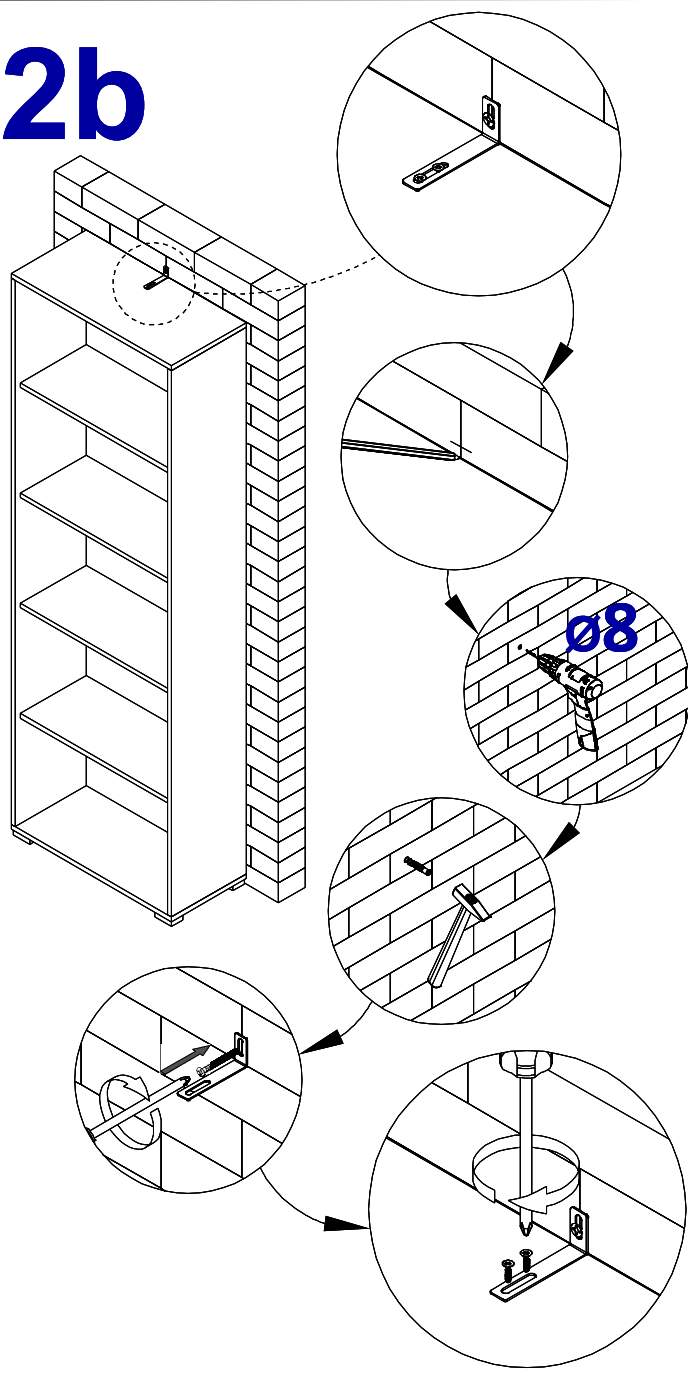

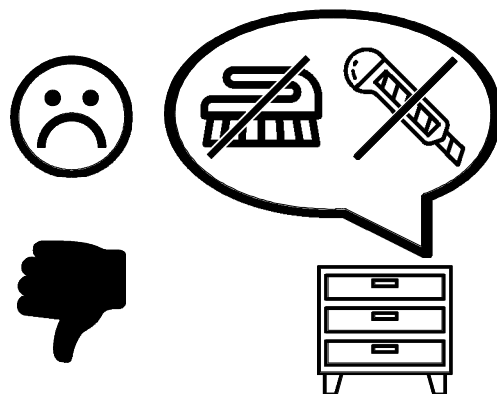
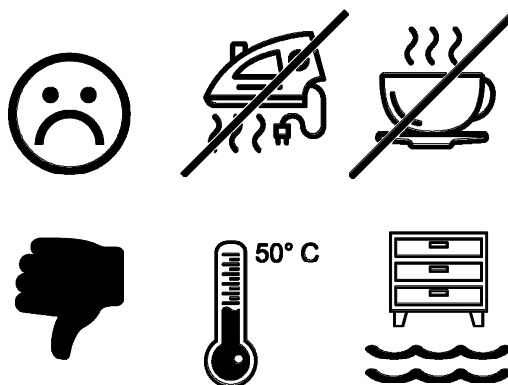
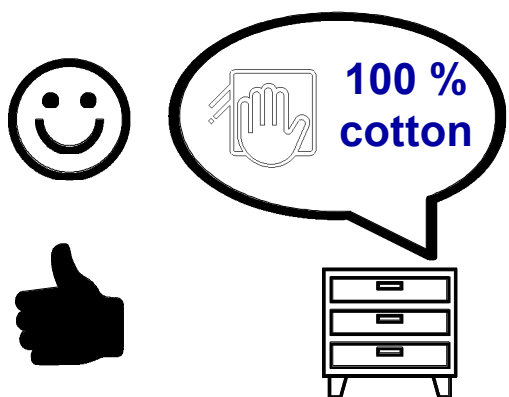

FR

Donnez ou recyclez
vos meubles.



ou



ou



Association

Magasin

Déchèterie

<https://quefairedemesdechets.fr>



CARTON
+ PLASTIQUE
+ NOTICE



Séparez les éléments
avant de trier