

# LORENZ

## LKZ 42416 / 75033

# 31/32

# 81/82

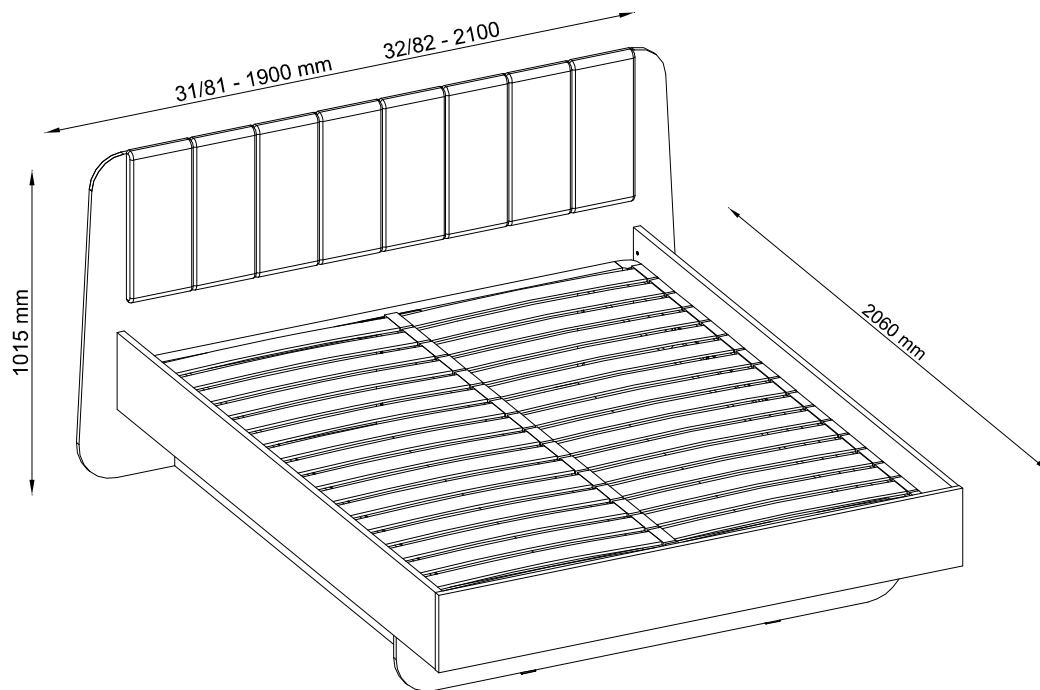

- |  |  |  |
|--|--|--|
| <b>D</b> <b>Montageanleitung</b><br>Betten >Lorenz<          | <b>GB</b> <b>Assembly instructions</b><br>Bed >Lorenz<     | <b>SRB</b> <b>Упутства за инсталацију</b><br>Лежај на кревету >Lorenz< |
| <b>FR</b> <b>Notice de montage</b><br>Le lit >Lorenz<        | <b>IT</b> <b>Intruzioni di montaggio</b><br>Letti >Lorenz< | <b>HR</b> <b>Upute za instalaciju</b><br>Krevet >Lorenz<               |
| <b>NL</b> <b>Handleiding voor de montage</b><br>Bed >Lorenz< | <b>PL</b> <b>Instrukcja montażu</b><br>Łoże >Lorenz<       | <b>SL</b> <b>Návod na montaž</b><br>Postelja >Lorenz<                  |
| <b>CZ</b> <b>Montážní návod</b><br>Postel >Lorenz<           | <b>SK</b> <b>Návod na montáž</b><br>Posteľ >Lorenz<        | <b>LT</b> <b>Surinkimo instrukcijos</b><br>Gulta >Lorenz<              |
| <b>HU</b> <b>Szerelési útmutató</b><br>Ágy >Lorenz<          | <b>RO</b> <b>Instructiuni de montaj</b><br>Pat >Lorenz<    | <b>LV</b> <b>Montāžas instrukcija</b><br>Lova >Lorenz<                 |
| <b>TR</b> <b>Montaj talinatl</b><br>Yatak >Lorenz<           | <b>RU</b> <b>Инструкция по монтажу</b><br>Кровати >Lorenz< | <b>EE</b> <b>Kokkupaneku juhised</b><br>Voodi >Lorenz<                 |
| <b>ES</b> <b>Instrucciones de montaje</b><br>Cama >Lorenz<   | <b>PT</b> <b>Instruções de montagem</b><br>Cama >Lorenz<   |  |

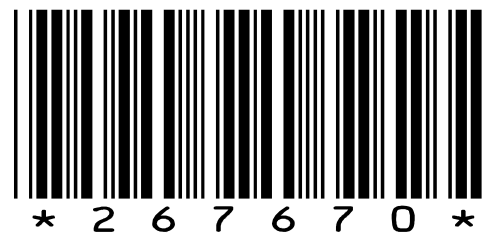
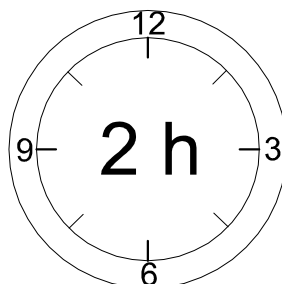
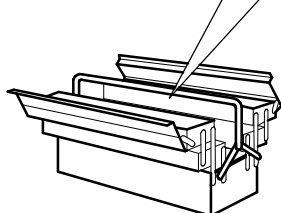
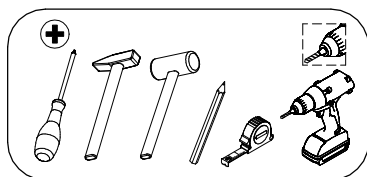

**D-**Ziehen Sie alle Schrauben sowie tragende Verbindungsteile nach ca. 5 Wochen nach, um einedauerhafte Standsicherheit zu gewährleisten.

**GB-**After approx. 5 weeks, tighten all screws and load-bearing connecting parts to ensure permanent stability.

**FR-**Resserrez toutes les vis ainsi que les pièces de fixation au bout d'environ 5 semaines pour garantir une sécurité de fixation durable.

**IT-** Ristringere tutte le viti e giunture dopo ca. 5 settimane, al fine di garantire una durevole solidità.

**NL-**Draai alle schroeven en ook dragende verbindingstukken na ca. 5 weken nog eens vast, zodateen continue stabiliteit wordt gegarandeerd.

**PL-**Prosimy po ok. 5 tygodniach dokręcić wszystkie śruby i elementy łączeniowe. Zagwarantuje to Państwu trwałość i stabilność połączeń.

**CZ-** Dotáhněte všechny šrouby a nosné spojovací díly přibližně po 5 týdnech, aby se zaručila trvalá stabilita.

**SK-**Po cca 5 týždňoch dotiahnite skrutky, aby bola zaručená ich trvalá stabilita.

**HU-**Húzza utána - kb. 5 hét múlva - az összes csavart és a teherhordó összekötő-alkatrészeket abiztonság érdekében.

**RO-**Pentru a asigura o stabilitate de durată, strângeți după cca. 5 săptămâni toate șuruburile, precumși toate elementele portante de legătură.

**TR-**Tüm vida ve taşıyıcı bağlantı parçalarını kalıcı bir duruş güvenliğini sağlamak için yaklaşık 5 haftasonra tekrar sıkınız.

**RU -** Подкрутите все болты, а также несущие соединительные детали припл. через 5 недель для обеспечения устойчивости в течение длительного времени.

**SRB -** Молим вас после акрокса. 5 недеља затегните све шрафове и причвршћиваче. То ће вам гарантовати трајност и стабилност веза.

**HR -** Molim vas, nakon cca. 5 tjedana zategnite sve vijke i pričvršćivače. To će vam jamčiti trajnost i stabilnost priključaka.

**SL -** Pýtame sa po cca. 5 týždňov utiahnite všetky skrutky a upevňovacie prvky. To zaručuje trvanlivosť a stabilitu spojov.

**LT -** Mes prašome po maždaug. 5 savaites priveržkite visus varžtus ir tvirtinimo detales. Taip užtikrinamas jungčių patvarumas ir stabilumas.

**LV -** Mēs lūdzam pēc apm. 5 nedēļas, pievelciet visas skrūves un stiprinājumus. Tas garantē savienojumu izturību un stabilitāti.

**EE -** Küsime pärast ca. 5 nädalat, pingutage kõiki kruvisid ja kinnitusi. See tagab ühenduste vastupidavuse ja stabiilsuse.

**ES -** Apriete todos los tornillos y elementos de conexión después de aprox. 5 semanas. Esto le garantizará la durabilidad y estabilidad de sus conexiones.

**PT -** Aperte todos os parafusos e elementos de ligação após aprox. 5 semanas. Isto garantirá a durabilidade e a estabilidade das suas ligações.

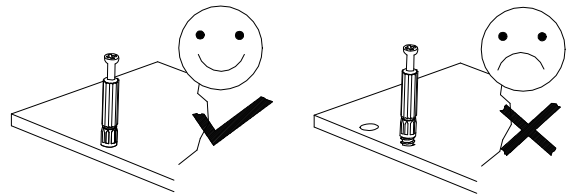

**D** Bitte nur mit einem Staubtuch oder leicht feuchtem Lappen reinigen. Keine scheuernden Putzmittel verwenden.

**GB** Please only clean with a duster or a damp cloth. Do not use any abrasive cleaners.

**FR** Veuillez nettoyer uniquement avec un chiffon à poussière ou un chiffon légèrement humide. Ne pas utiliser de détergent abrasif.

**IT** Si raccomanda di pulire solo con un panno per la polvere o uno strofinaccio umido. Non utilizzare detersivi abrasivi.

**NL** Reinig alleen met een stofdoek of een lichtjes vochtige doek. Gebruik geen schurende poetsmiddelen.

**PL** Czyszczenie należy wykonać wyłącznie za pomocą ściereczki lub lekko nawilżonego ręcznika. Nie stosować środków czyszczących do szorowania.

**CZ** Čistěte prosím jen prachovkou nebo lehce navlhčeným hadrem. Nepoužívejte drhňoucí čisticí prostředky.

**SK** Na čistenie používajte len prachovku alebo zľahka navlhčenú utierku. Nepoužívajte žiadne drhňúce čistiace prostriedky.

**HU** Kérjük, csak portórló kendővel vagy enyhén nedves ronggyal tisztítsa. Ne használjon dörzshatású tisztítószeret.

**RO** Vă rugăm să utilizați la curățare exclusiv o cârpă de șters praful sau o cârpă ușor umezită. Nu utilizați substanțe de curățat abrazive.

**TR** Lütfen sadece bir toz bezikle veya hafif nemli yumuşak bir bezle siliniz. Aşındırıcı temizlik malze-meleri kullanmayınız.

**RU** Для чистки используйте, пожалуйста, тряпку для пыли или слегка влажную ветошь. Не использовать абразивные чистящие средства.

**SBR** Чишћење треба обавити само крпом или благо влажним пешкиром. Немојте користити средство за чишћење рибанја.

**HR** Čišćenje treba obaviti samo krpom ili blago navlaženim ručnikom. Ne koristite sredstva za čišćenje ribanja.

**SL** Čistenie by sa malo vykonávať len handričkou alebo ľahko navlhčeným uterákom. Nepoužívajte čistiace prostriedky na drhnutie.

**LT** Valyti galima tik šluoste arba lengvai sudrėkintu rankšluosčiu. Nenaudokite šveičiamųjų valiklių.

**LV** Tīršana jāveic tikai ar drānu vai viegli samitrinātu dvieli. Neizmantojiet tīršanas līdzekļus.

**EE** Puhastada tohib ainult lapiga või kergelt niisutatud rätikuga. Ärge kasutage puhastusvahendeid.

**PT** A limpeza deve ser feita apenas com um pano ou toalha ligeiramente húmida. Não utilize produtos de limpeza abrasivos.

**ES** La limpieza debe realizarse únicamente con un paño o toalla ligeramente húmedo. No utilice agentes de limpieza abrasivos.

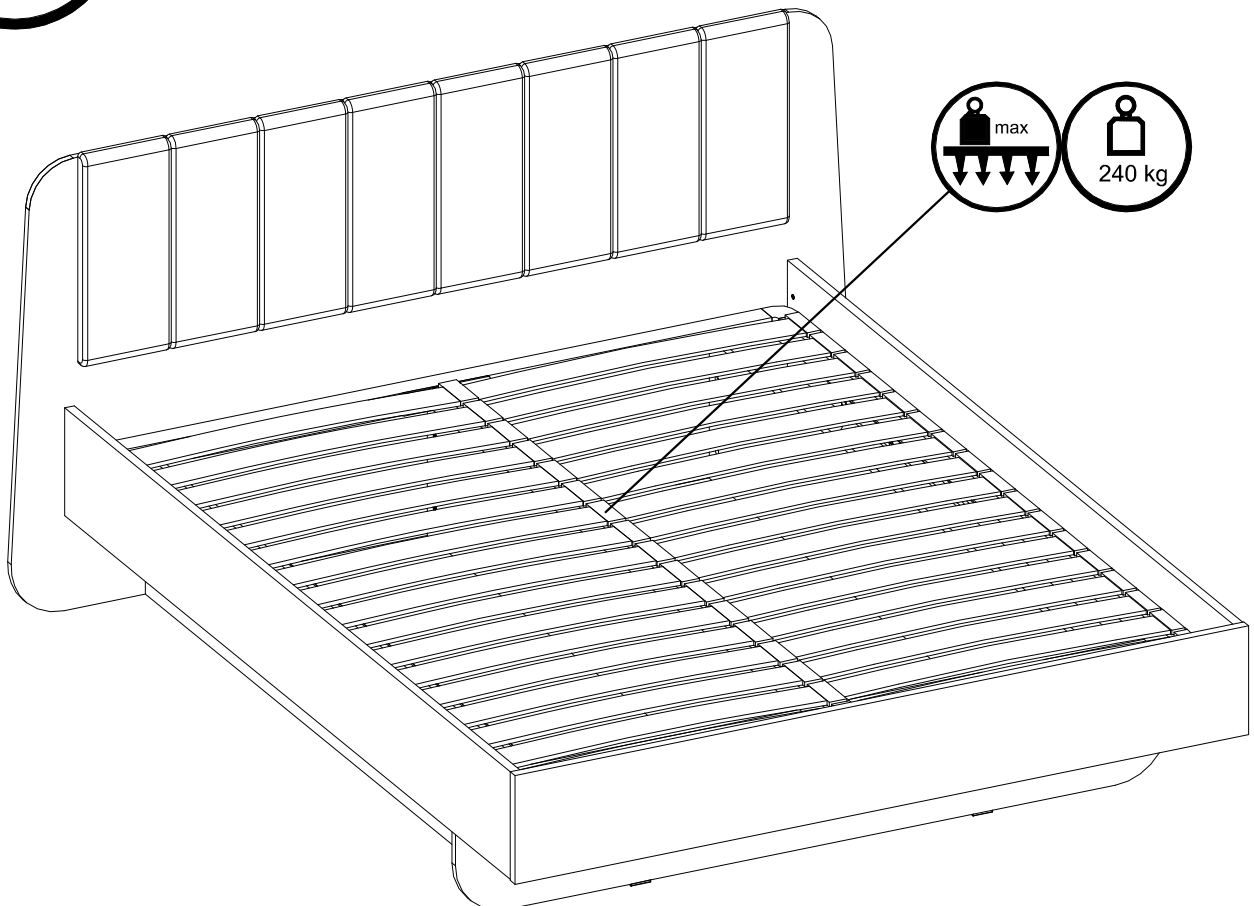
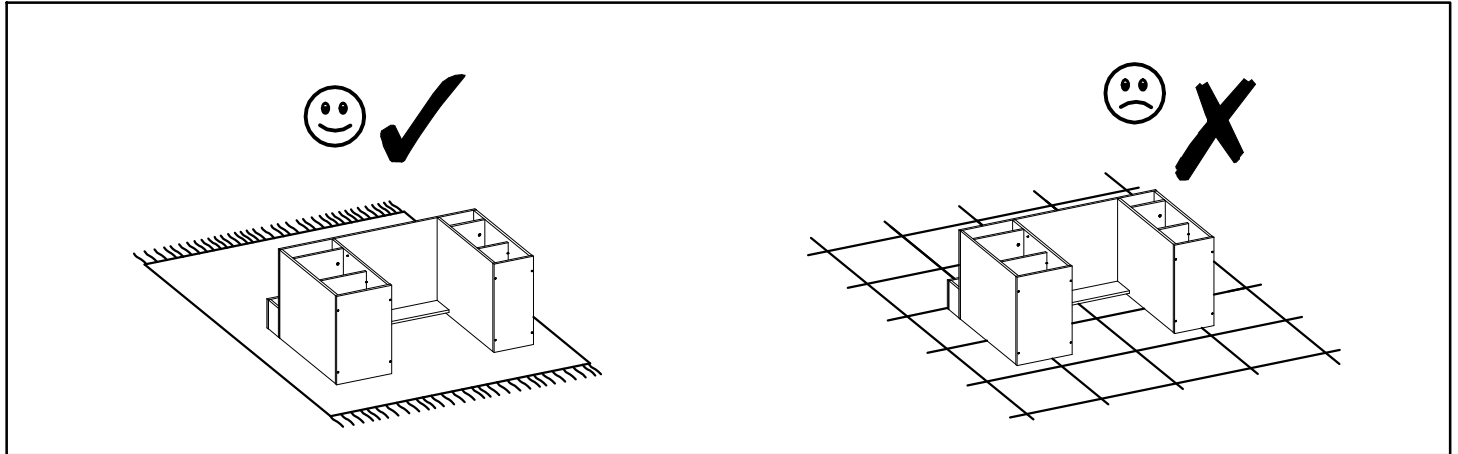
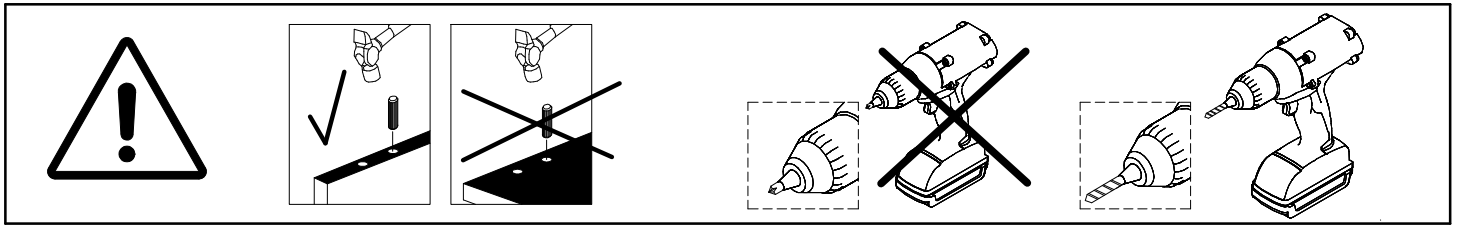
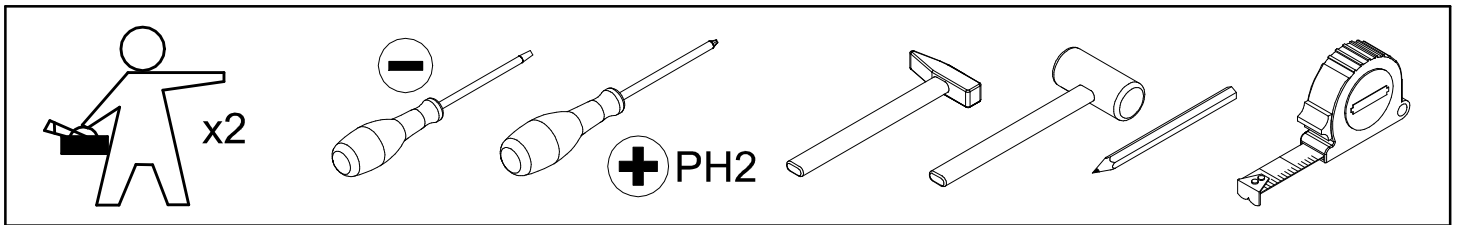

# Service · Assistenza · Dienstverlening · Serwis Servis · Szerviz · Сервисная служба · Сервис · Serwis · Servis

Name · Nom · Nome · Naam · Nazwa · Jméno · Názov · Név · Denumire · Isim · Название	<b>LORENZ</b>
Typ · Type · Tip · Típus · Тіро · Тип	31 / 81 32 / 82

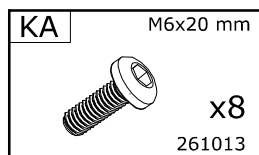
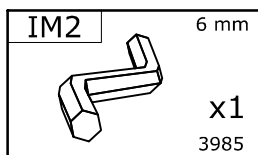
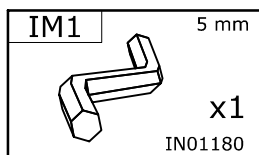
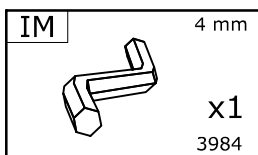
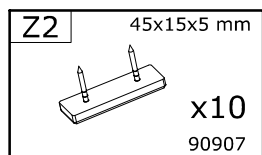
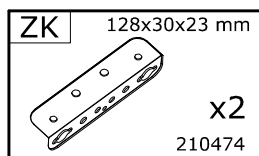
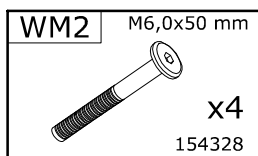
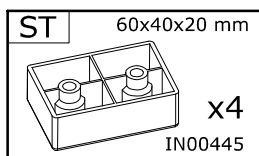
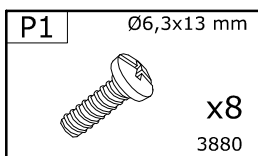
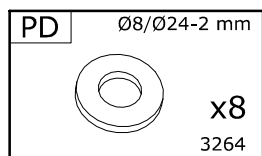
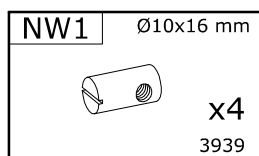
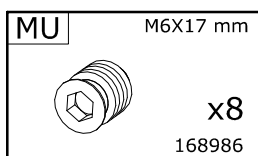
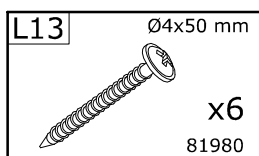
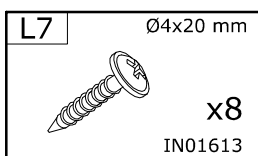
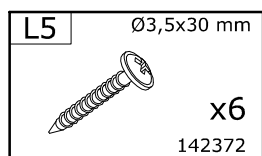
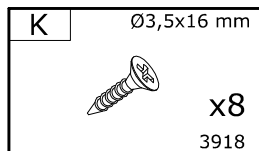
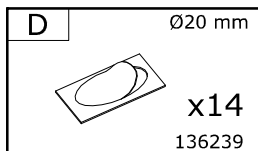
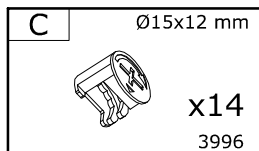
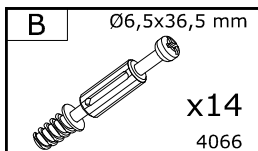
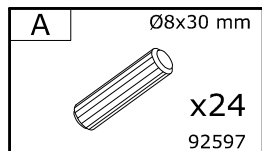
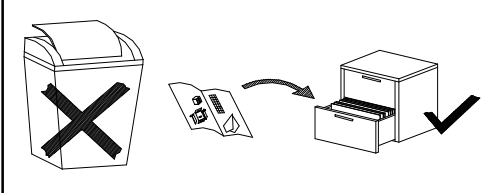
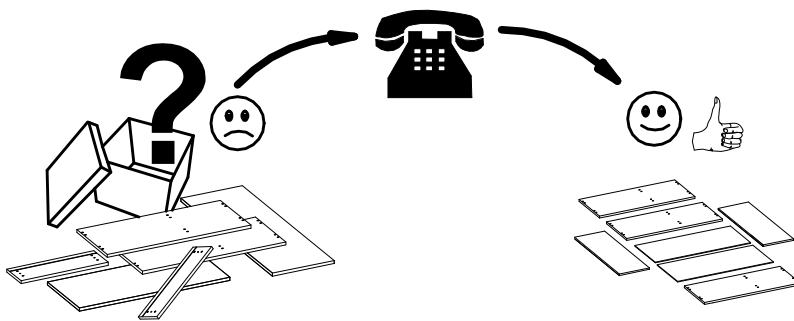

# 31/32

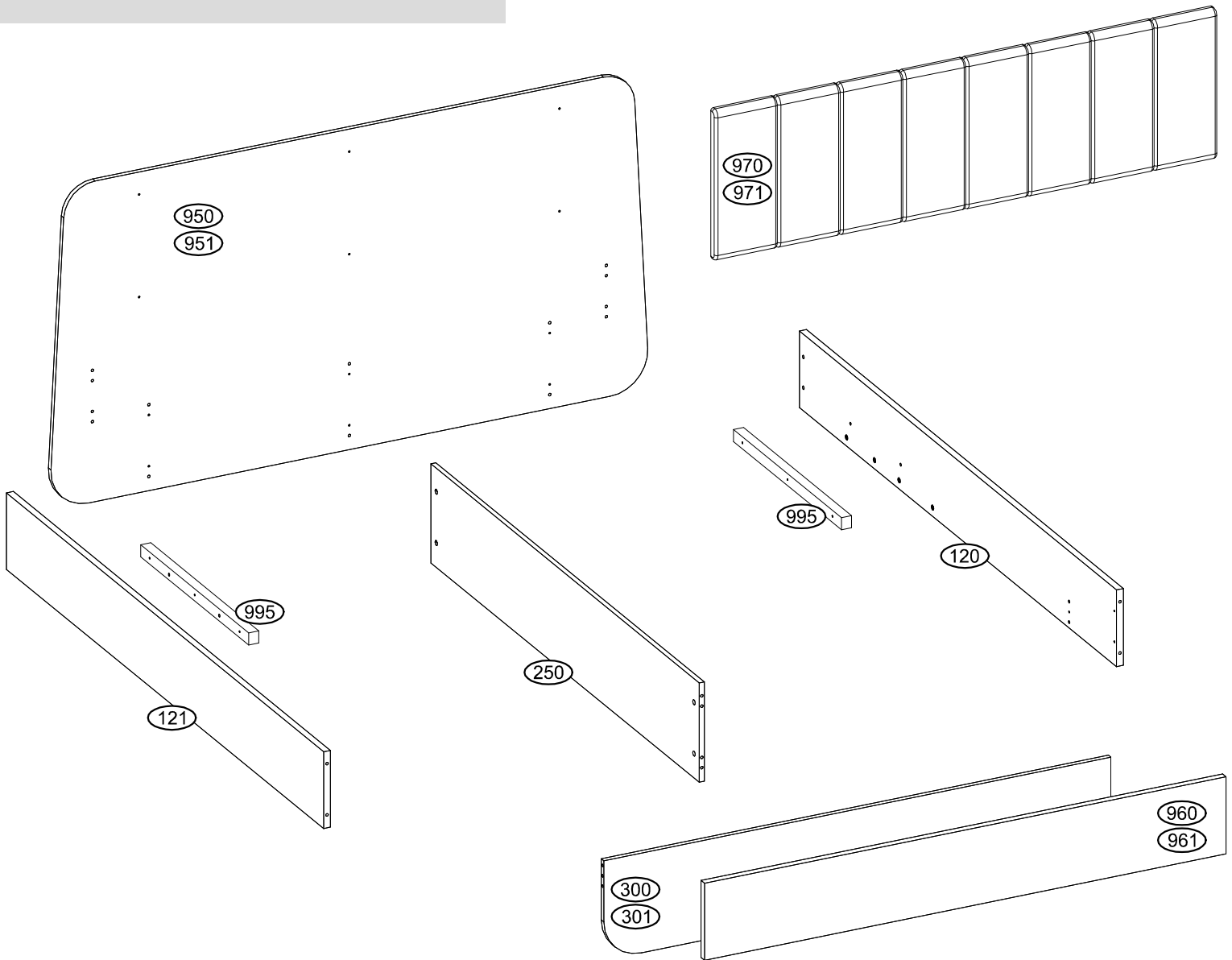

<b>LORENZ 31</b>	950	300	960	970
------------------	-----	-----	-----	-----

<b>LORENZ 32</b>	951	301	961	971
------------------	-----	-----	-----	-----

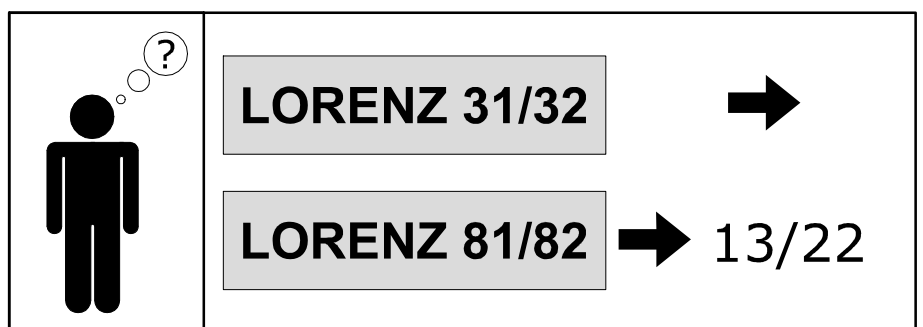

1

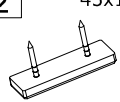
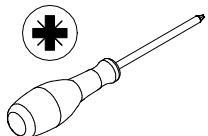
<b>B</b> $\varnothing 6,5 \times 36,5$ mm  x2 4066	<b>Z2</b> 45x15x5 mm  x3 90907	
---	---	--

# 31/32

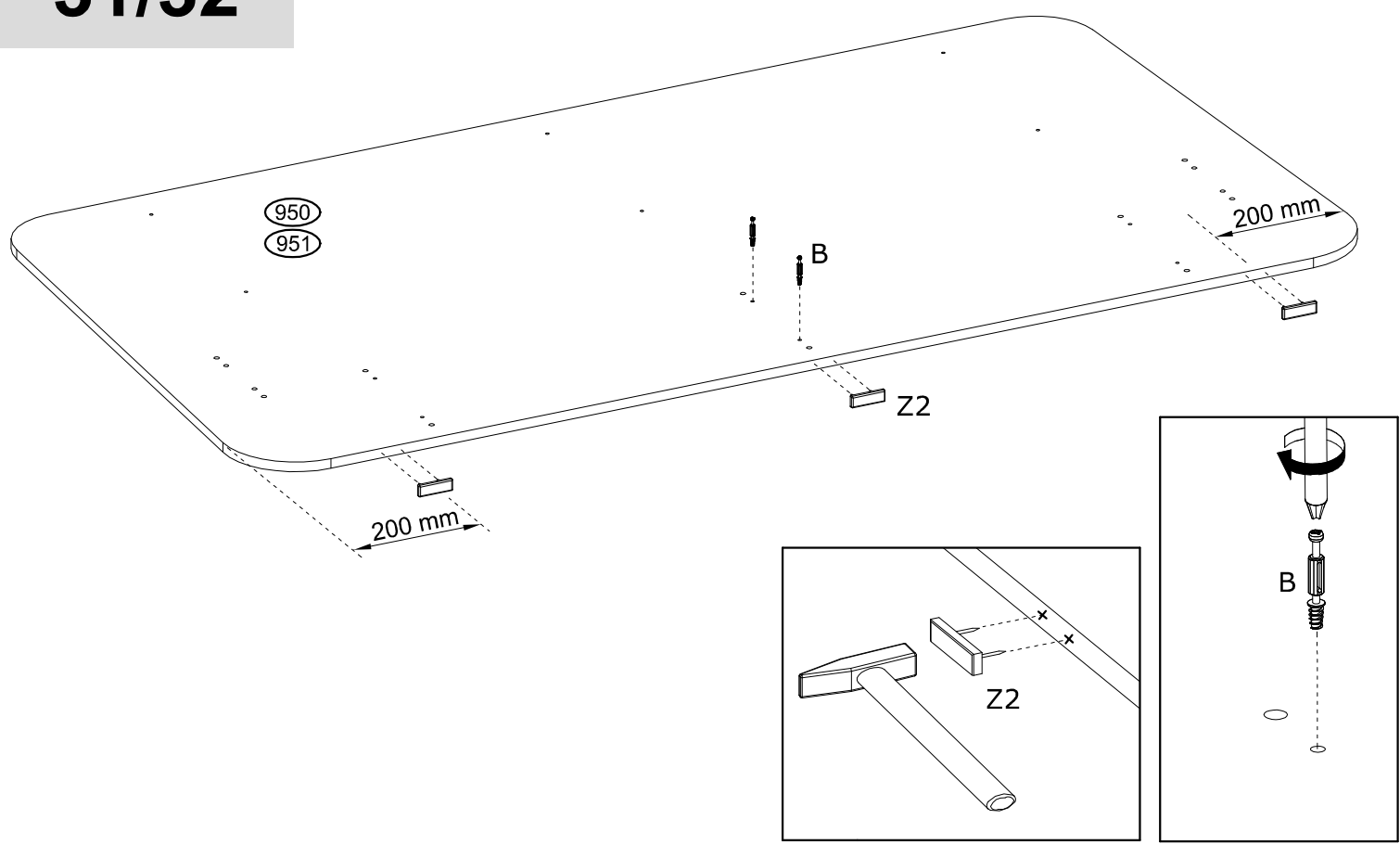

2

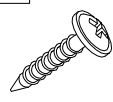
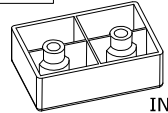
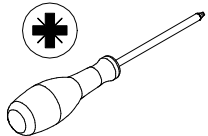
<b>L7</b> $\varnothing 4 \times 20$ mm  x4 IN01613	<b>ST</b> 60x40x20 mm  x2 IN00445	
--	---	---

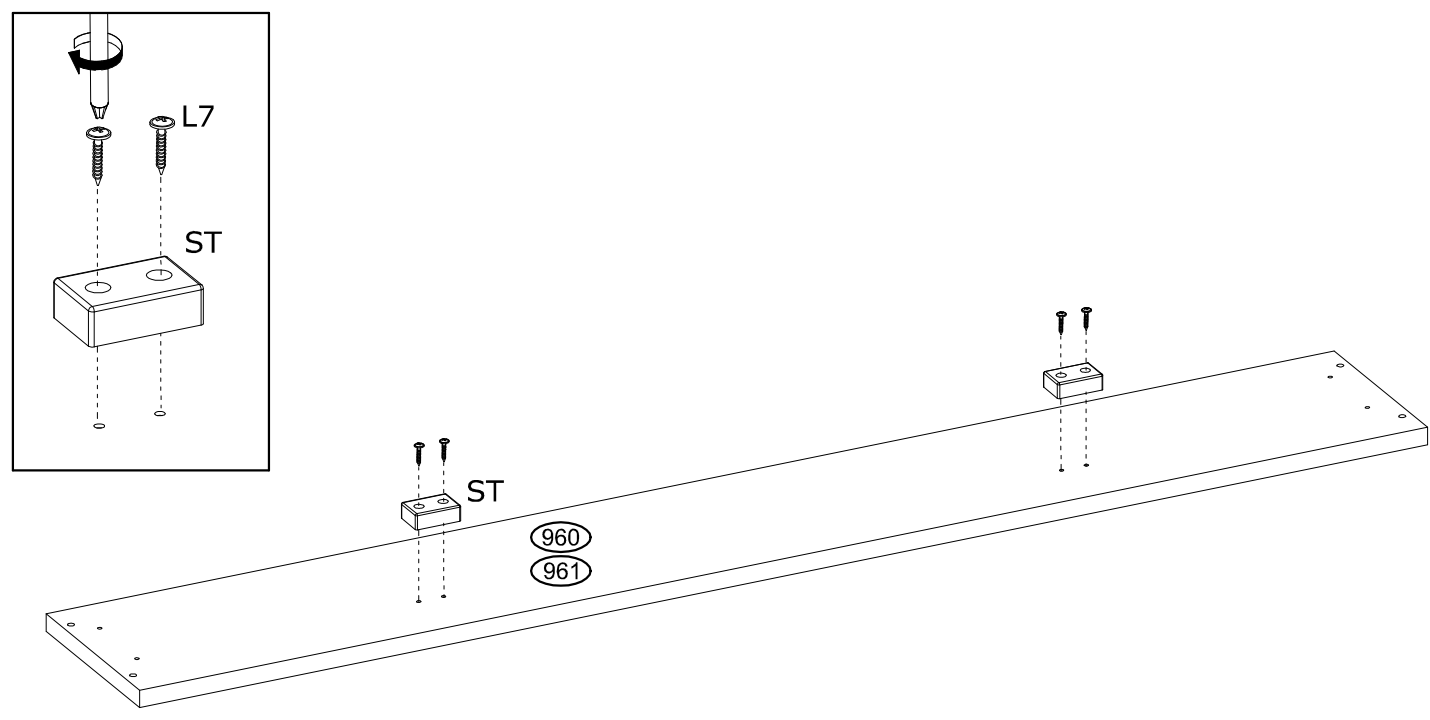

3

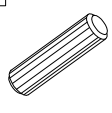
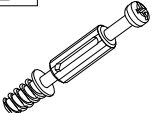
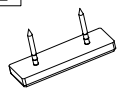
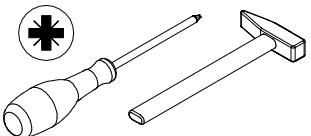
<p><b>A</b>    <math>\varnothing 8 \times 30</math> mm</p>  <p>x4 92597</p>	<p><b>B</b>    <math>\varnothing 6,5 \times 36,5</math> mm</p>  <p>x2 4066</p>	<p><b>Z2</b>    45x15x5 mm</p>  <p>x3 90907</p>	
---	--	---	--

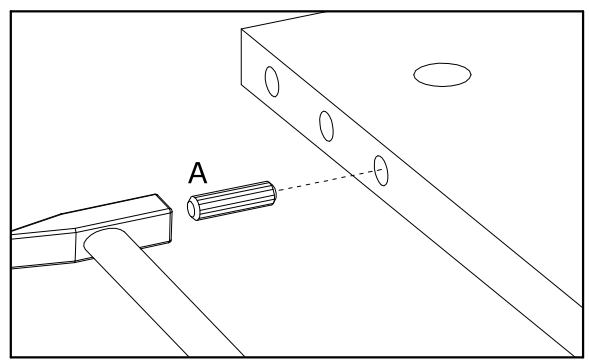
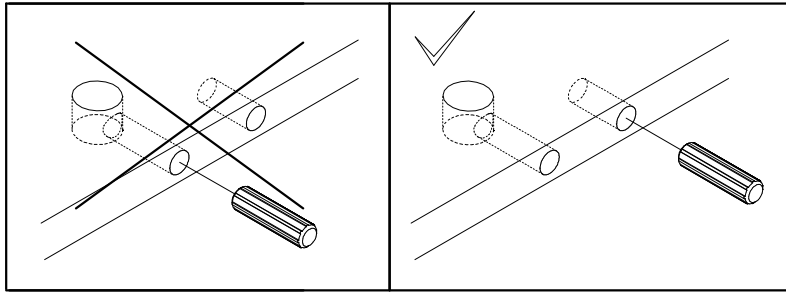
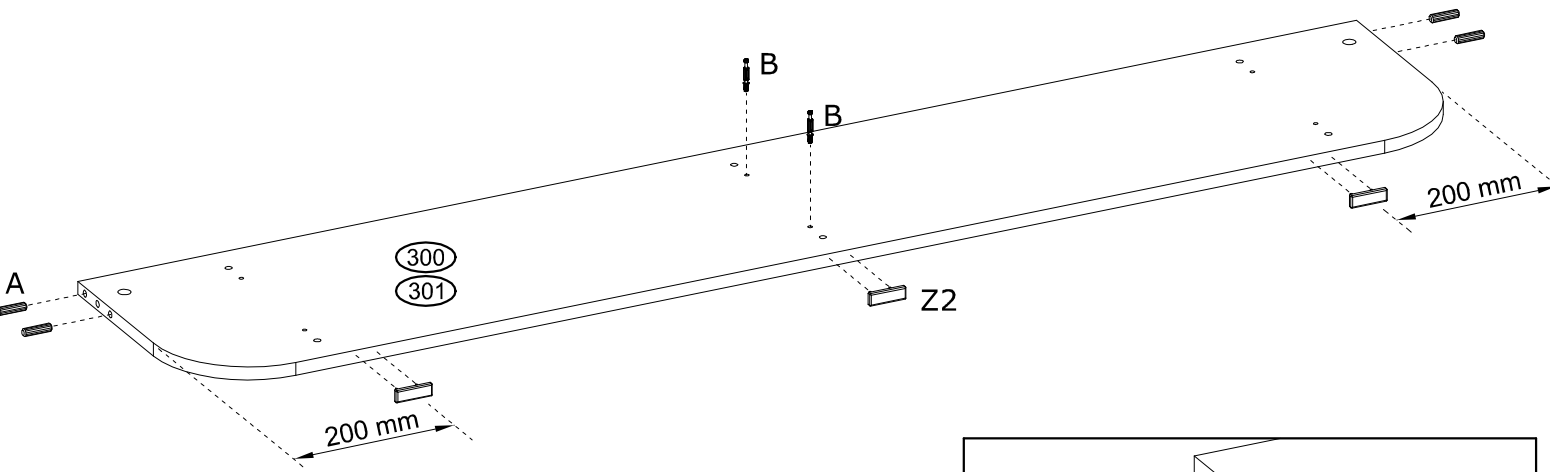

4

<p><b>A</b>    <math>\varnothing 8 \times 30</math> mm</p>  <p>x4 92597</p>	<p><b>Z2</b>    45x15x5 mm</p>  <p>x2 90907</p>	
--	--	---

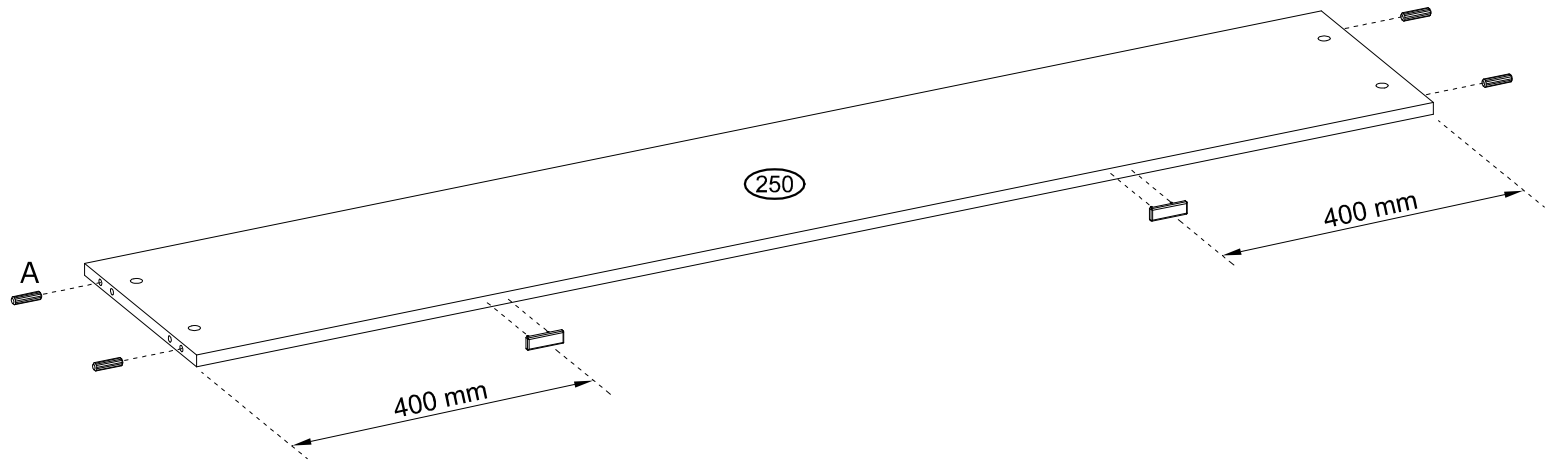



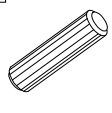
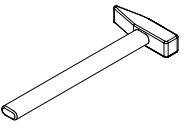

5

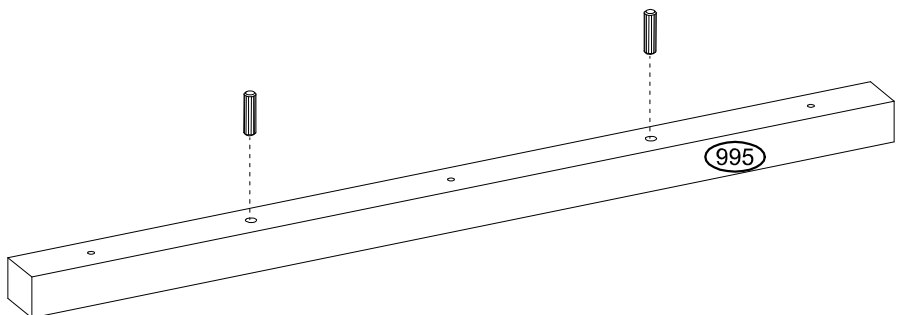
<p><b>A</b>    <math>\varnothing 8 \times 30</math> mm</p>  <p>x4 92597</p>	
--	---

x2

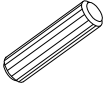
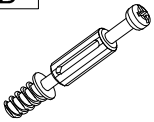

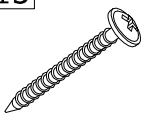
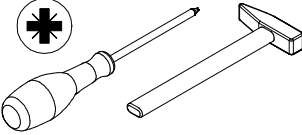

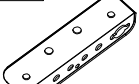

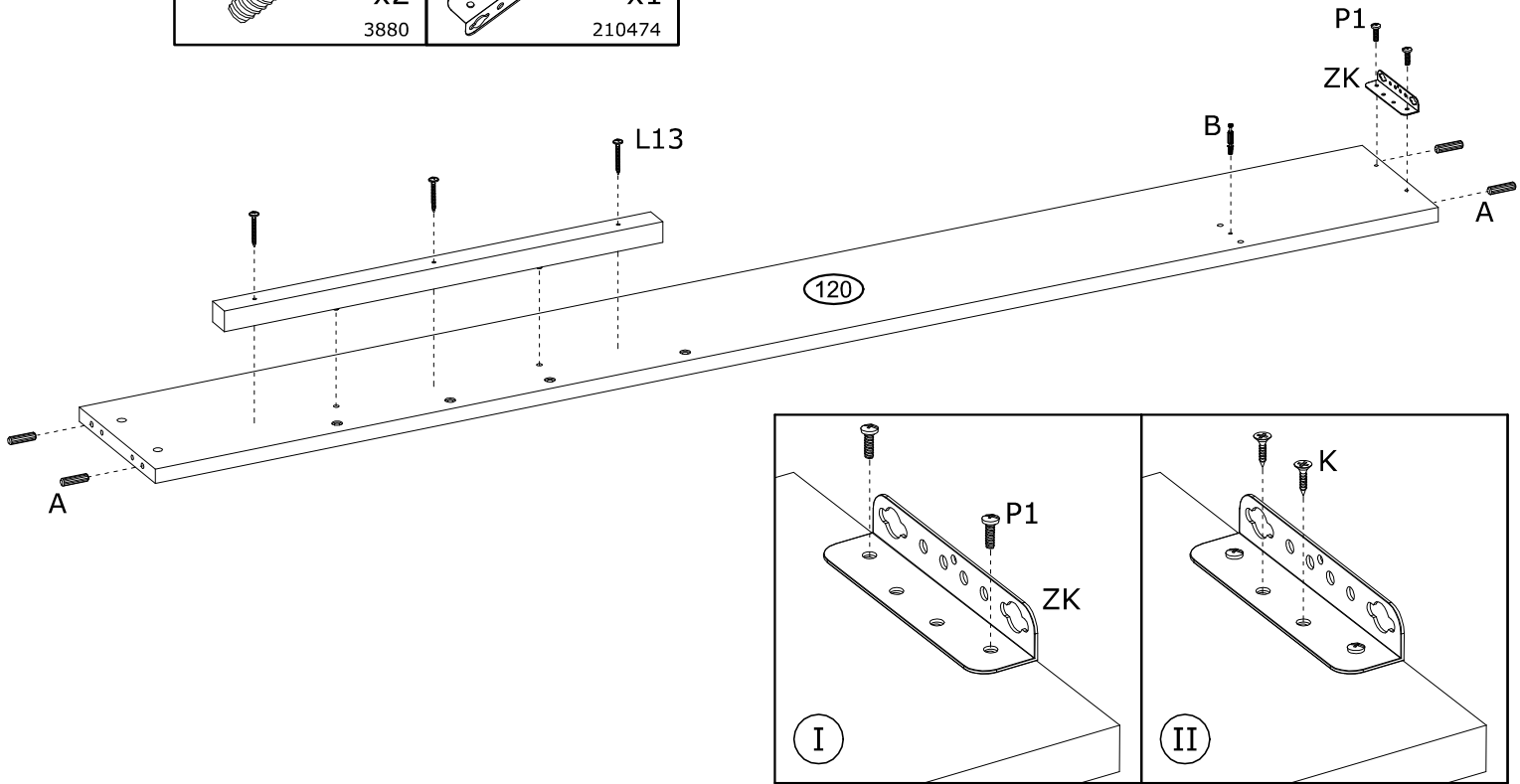
6

<b>A</b> Ø8x30 mm  x4 92597	<b>B</b> Ø6,5x36,5 mm  x1 4066	<b>K</b> Ø3,5x16 mm  x2 3918	<b>L13</b> Ø4x50 mm  x3 81980	
<b>P1</b> Ø6,3x13 mm  x2 3880	<b>ZK</b> 128x30x23 mm  x1 210474			

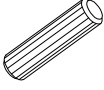
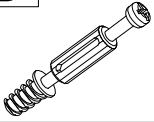

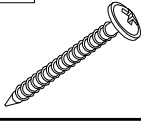
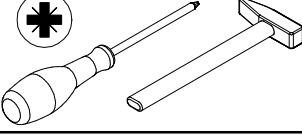
7

<b>A</b> Ø8x30 mm  x4 92597	<b>B</b> Ø6,5x36,5 mm  x1 4066	<b>K</b> Ø3,5x16 mm  x2 3918	<b>L13</b> Ø4x50 mm  x3 81980	
<b>P1</b> Ø6,3x13 mm  x2 3880	<b>ZK</b> 128x30x23 mm  x1 210474			

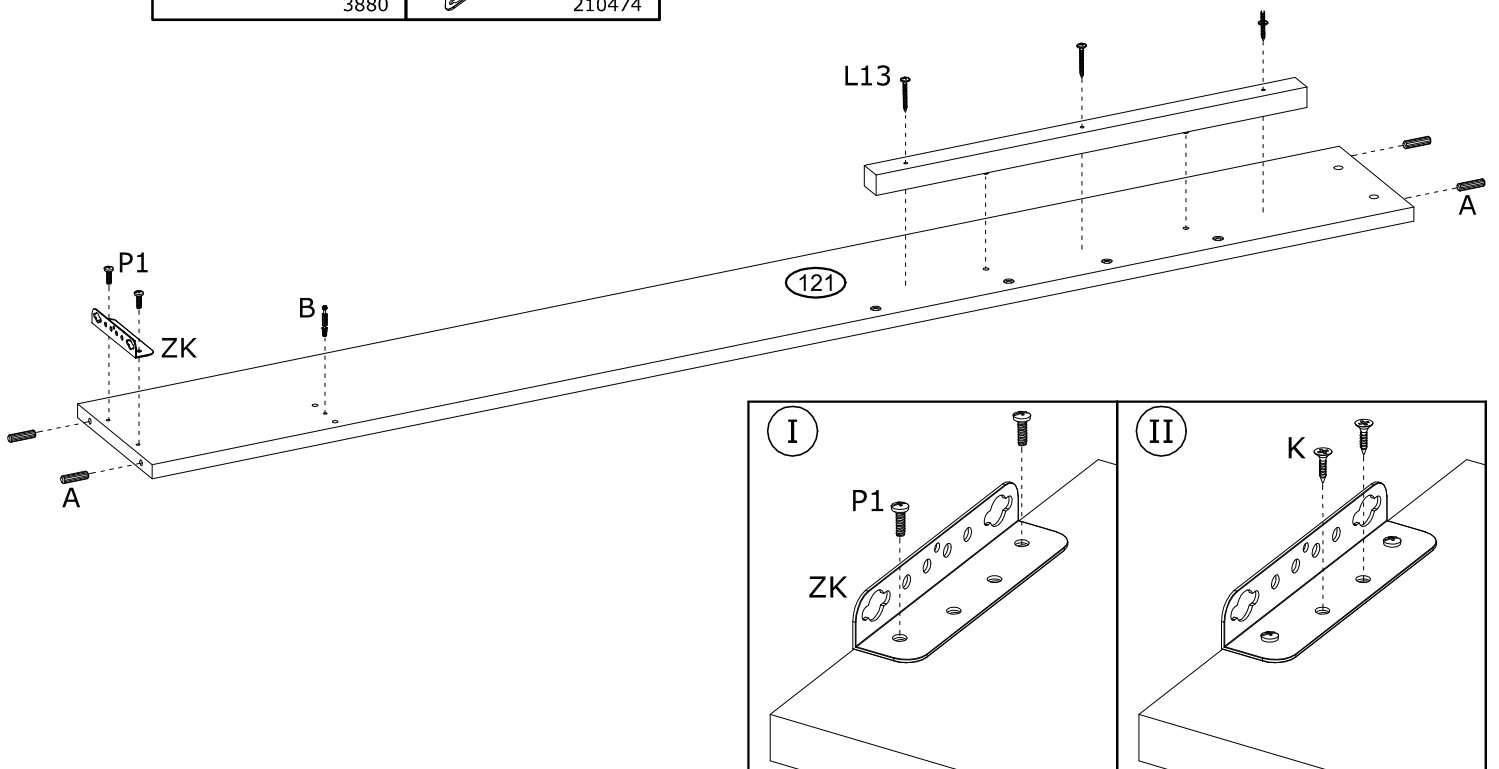





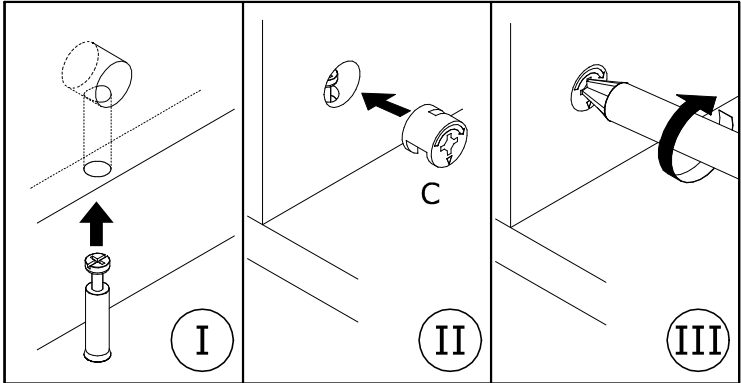
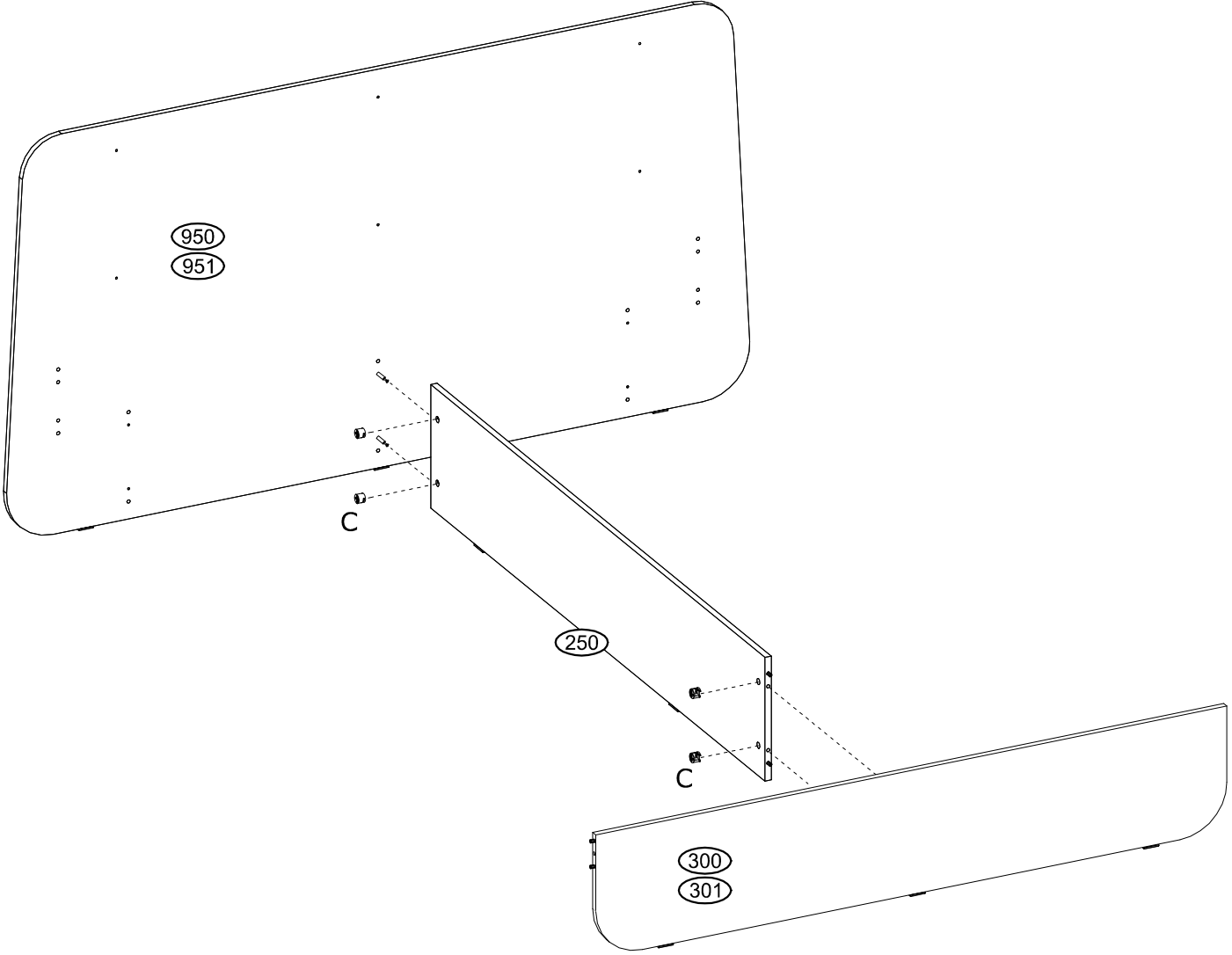
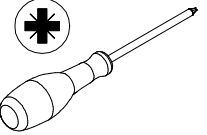

8

C  
Ø15x12 mm  
x4  
3996

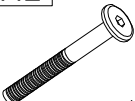

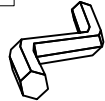
9

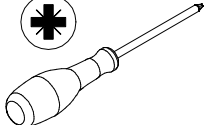
<p><b>C</b> Ø15x12 mm                    x2                  3996</p>	<p><b>NW1</b> Ø10x16 mm                    x4                  3939</p>	<p><b>WM2</b> M6,0x50 mm                    x4                  154328</p>	<p> x2</p>	<p><b>IM</b> 4 mm      </p>
---	---	--	---	---

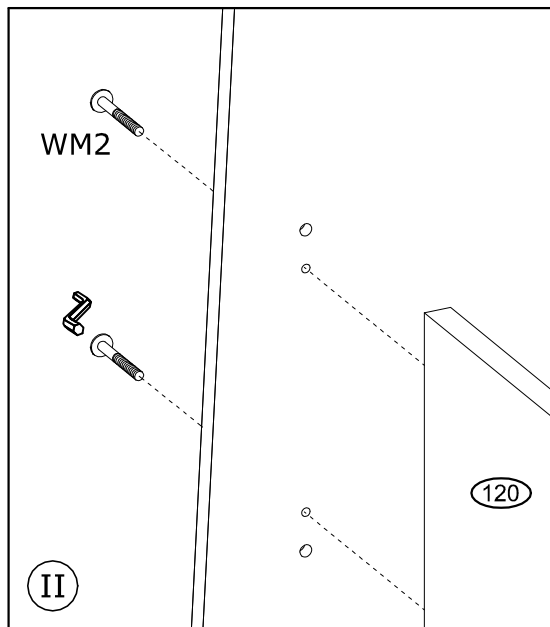
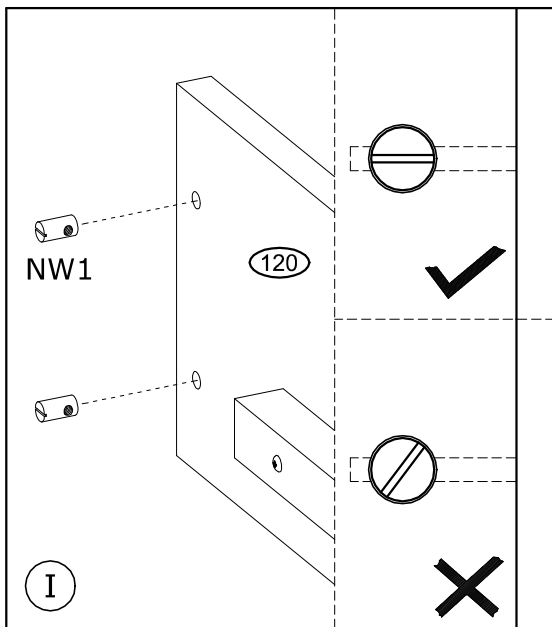
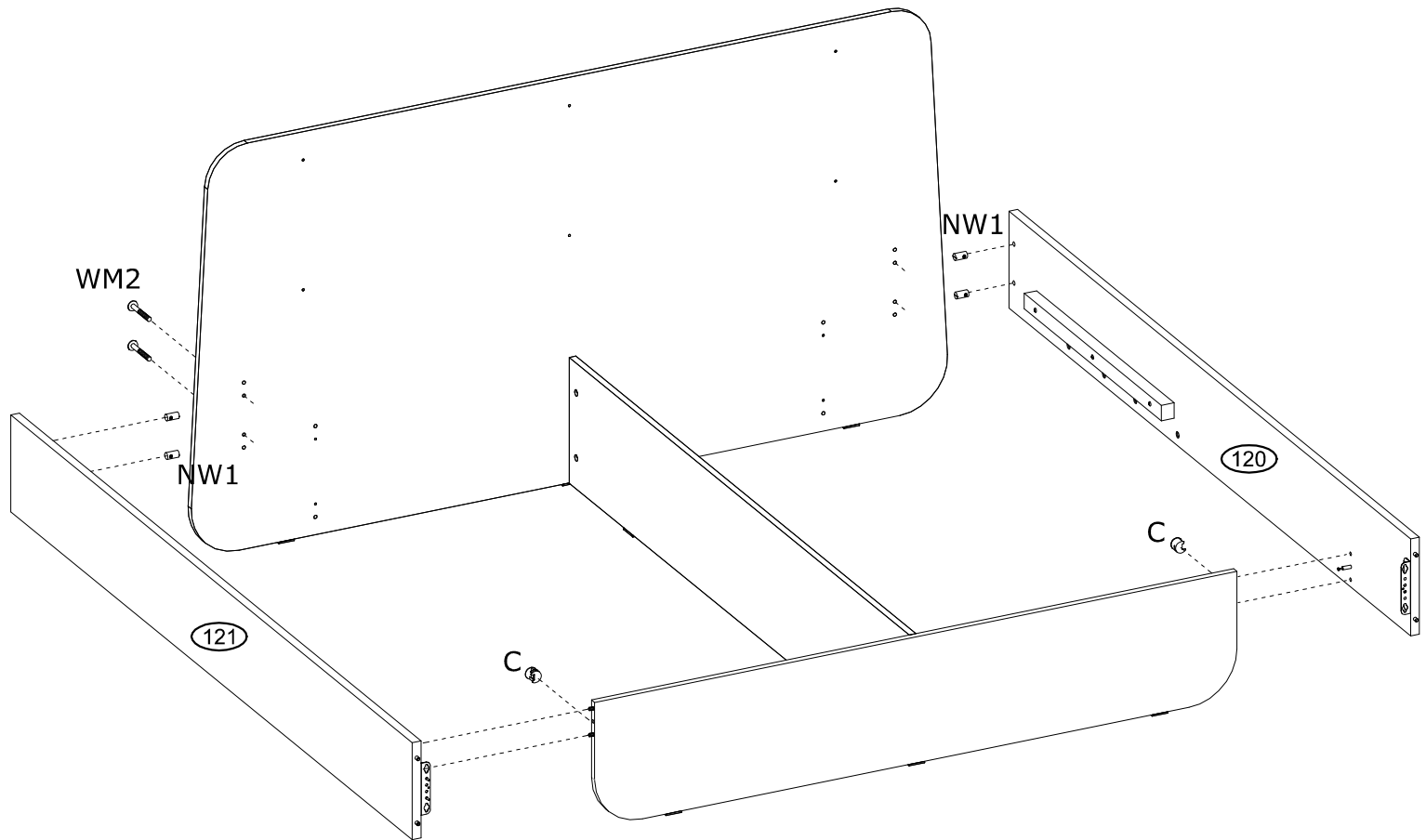
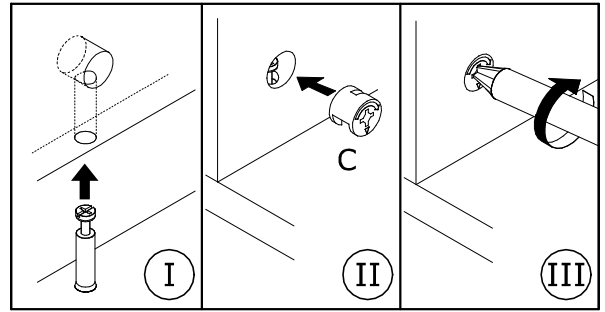

# 10

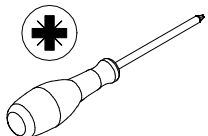
<b>K</b>	Ø3,5x16 mm	<b>P1</b>	Ø6,3x13 mm	<b>D</b>	Ø20 mm	
	x4 3918		x4 3880		x14 136239	

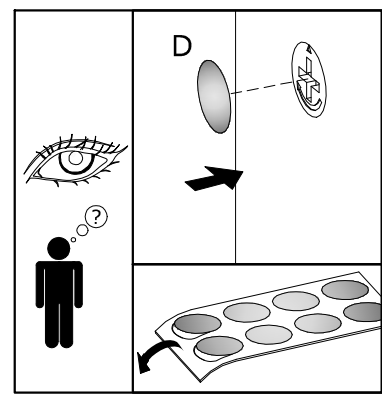
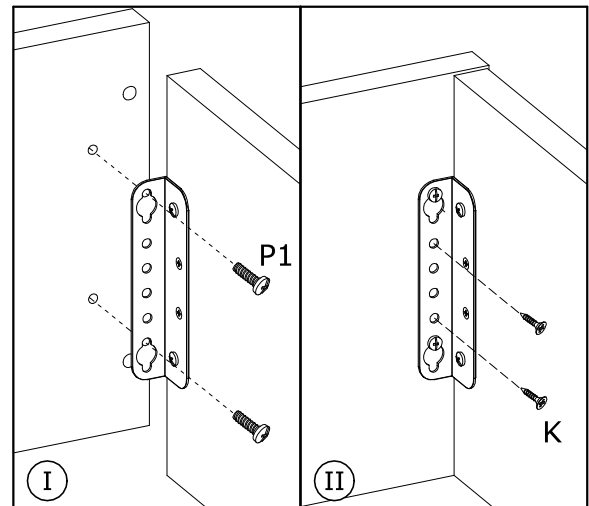
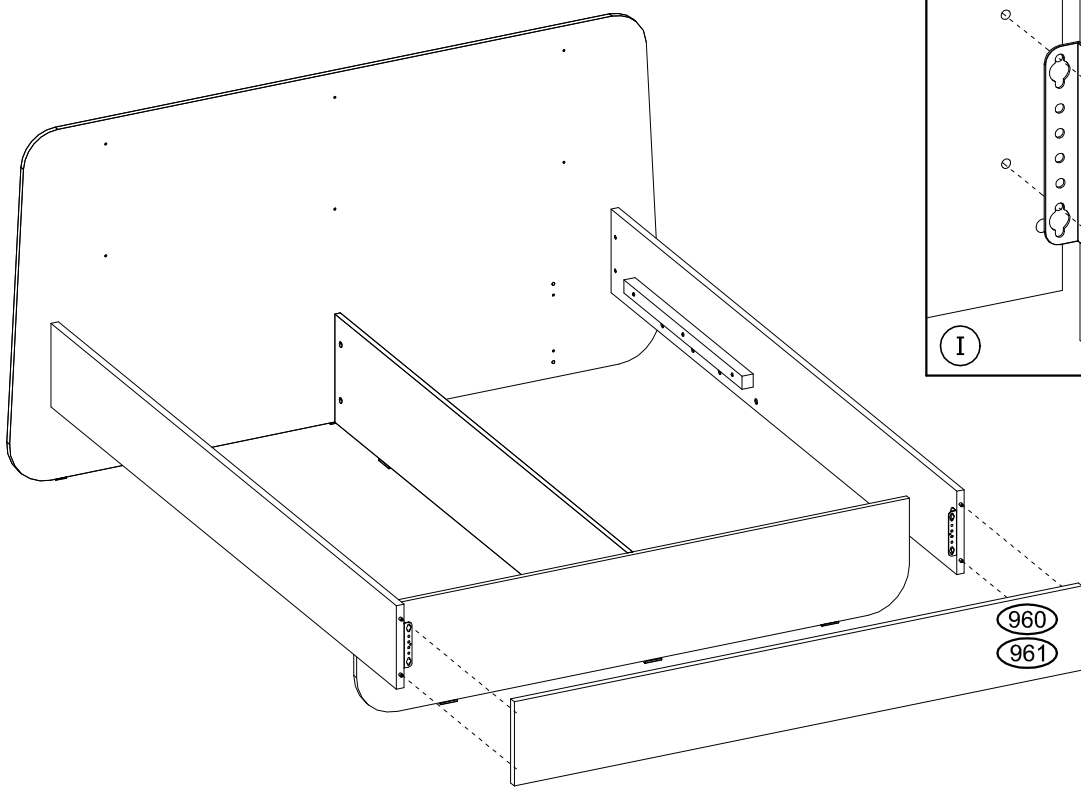

# 11

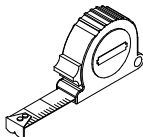
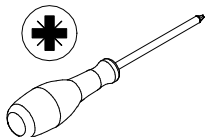
<b>L5</b>	Ø3,5x30 mm	 x2		
	x6 142372			

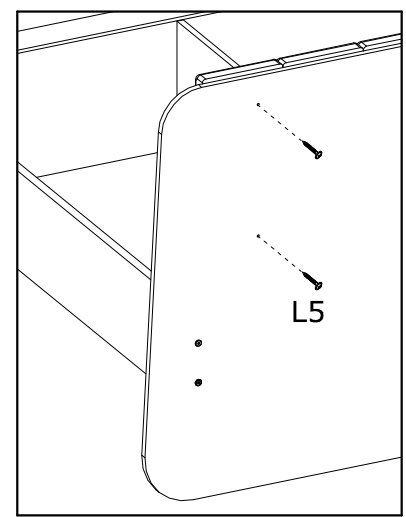
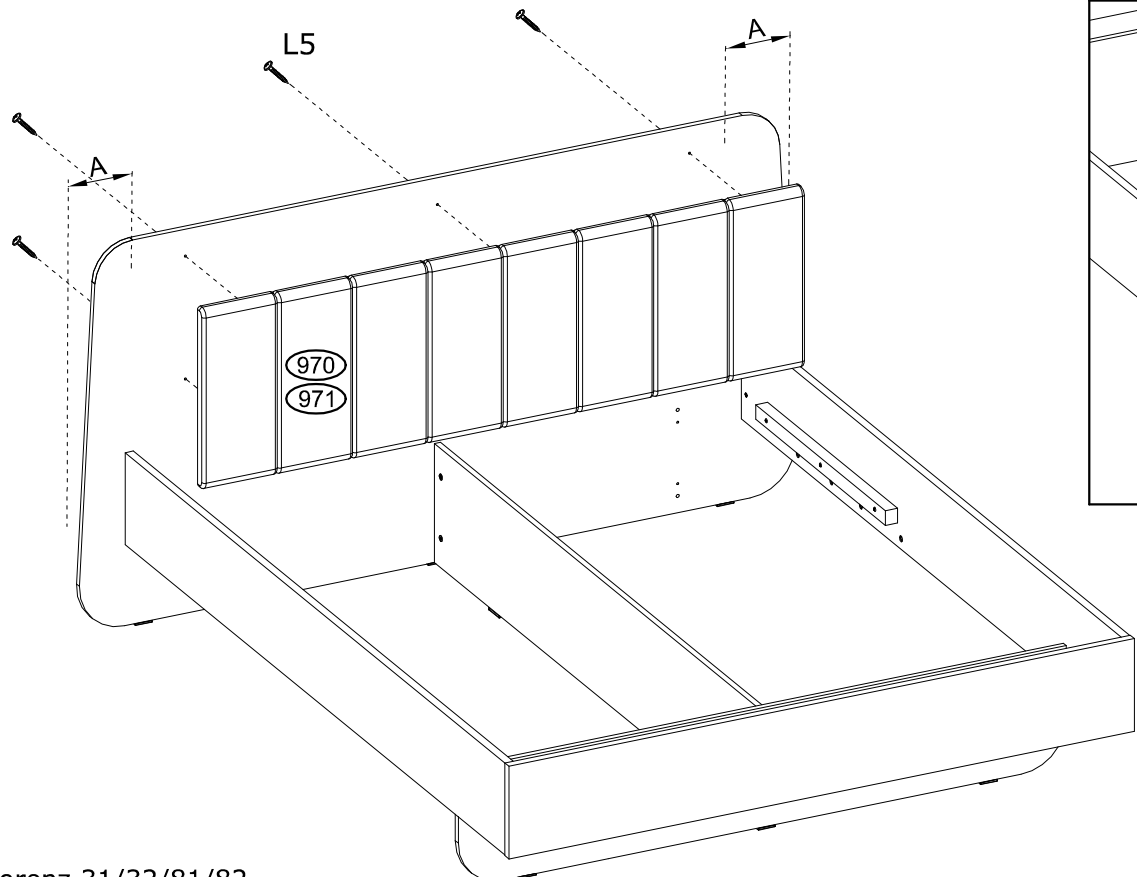

12

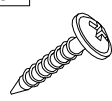
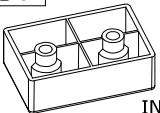
<b>L7</b>  Ø4x20 mm x4 IN01613	<b>ST</b>  60x40x20 mm x2 IN00445
--	---

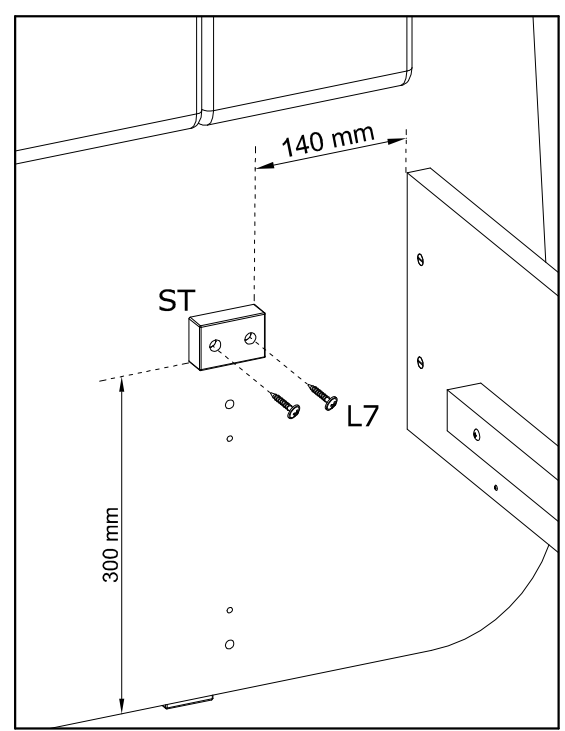
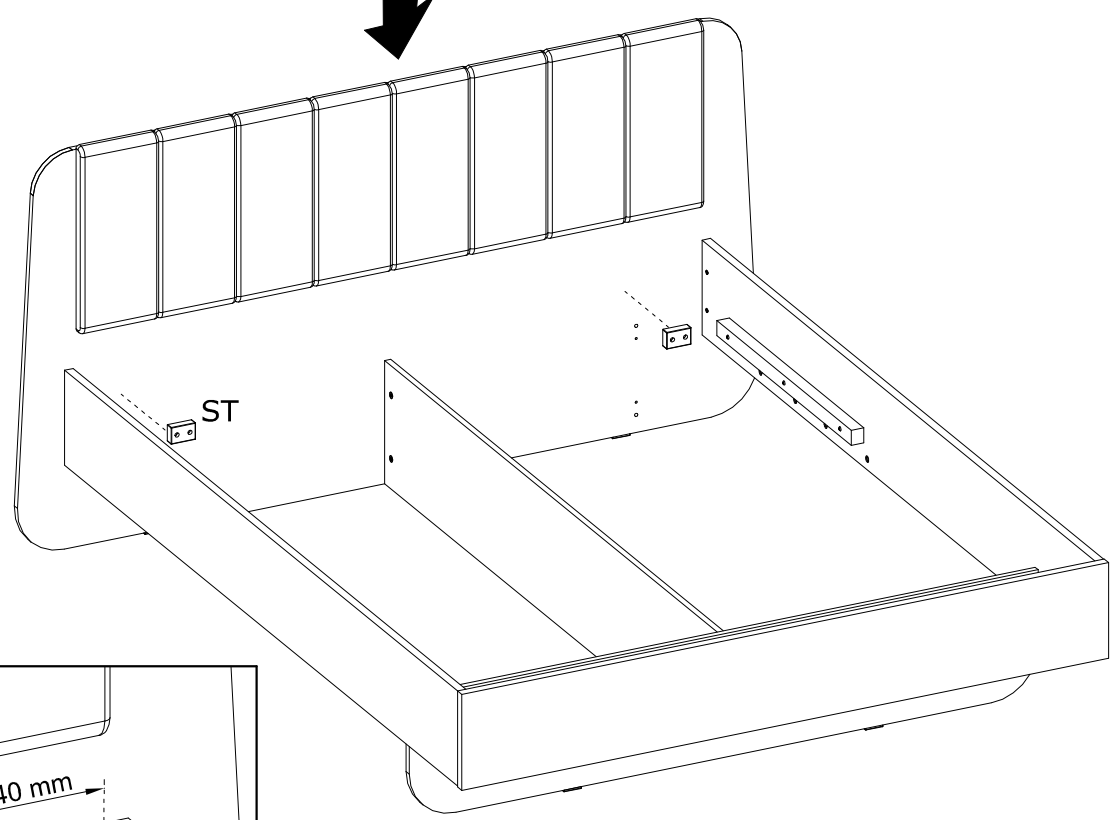
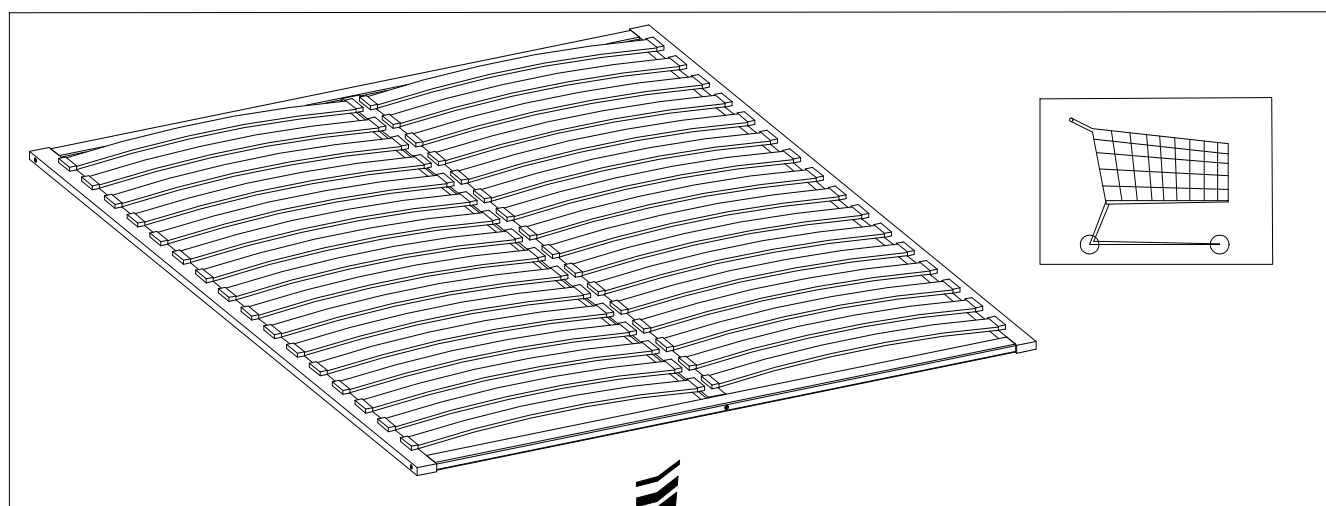
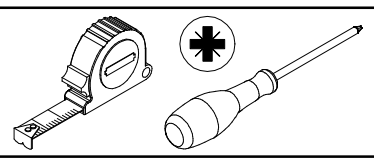

# 81/82

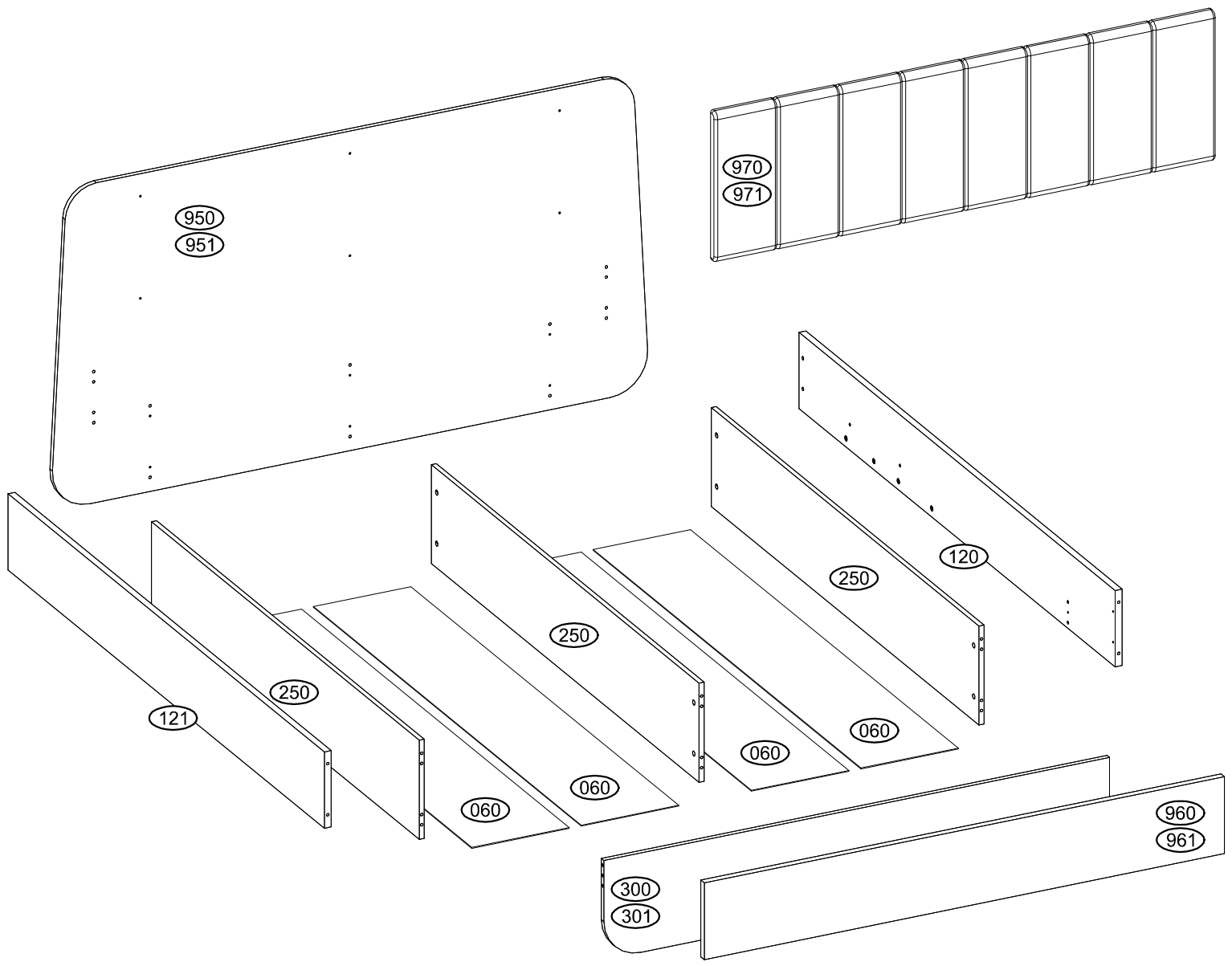

<b>LORENZ 81</b>	950	300	960	970
------------------	-----	-----	-----	-----

<b>LORENZ 82</b>	951	301	961	971
------------------	-----	-----	-----	-----

1

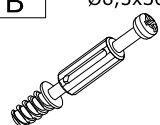
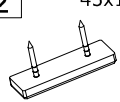
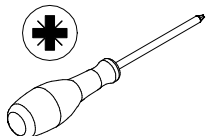
<b>B</b> Ø6,5x36,5 mm  <b>x6</b> 4066	<b>Z2</b> 45x15x5 mm  <b>x2</b> 90907	
--	--	--

# 81/82

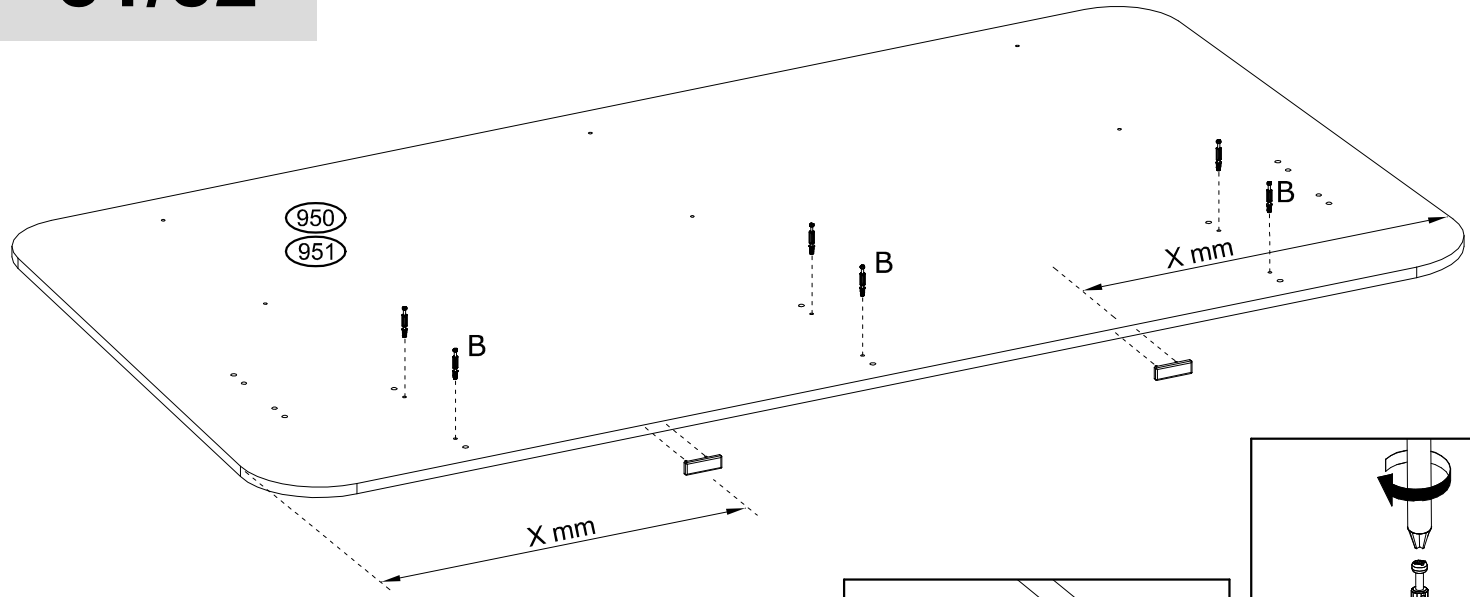

<b>81</b>	<b>X = 630 mm</b>
<b>82</b>	<b>X = 730 mm</b>

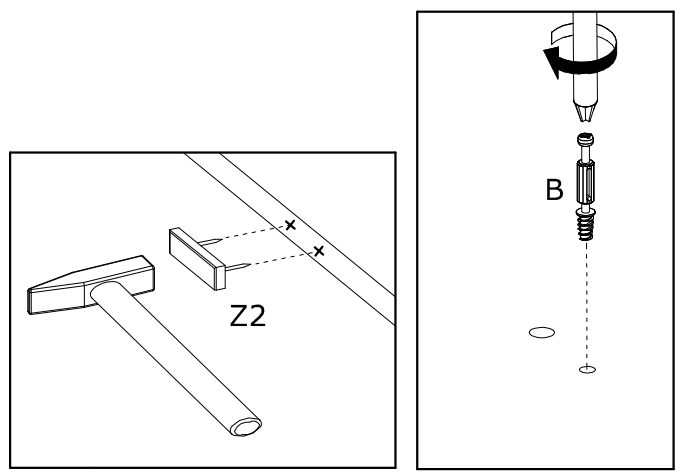

2

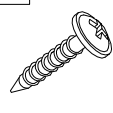
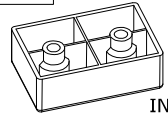
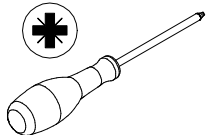
<b>L7</b> Ø4x20 mm  <b>x4</b> IN01613	<b>ST</b> 60x40x20 mm  <b>x2</b> IN00445	
---	--	---

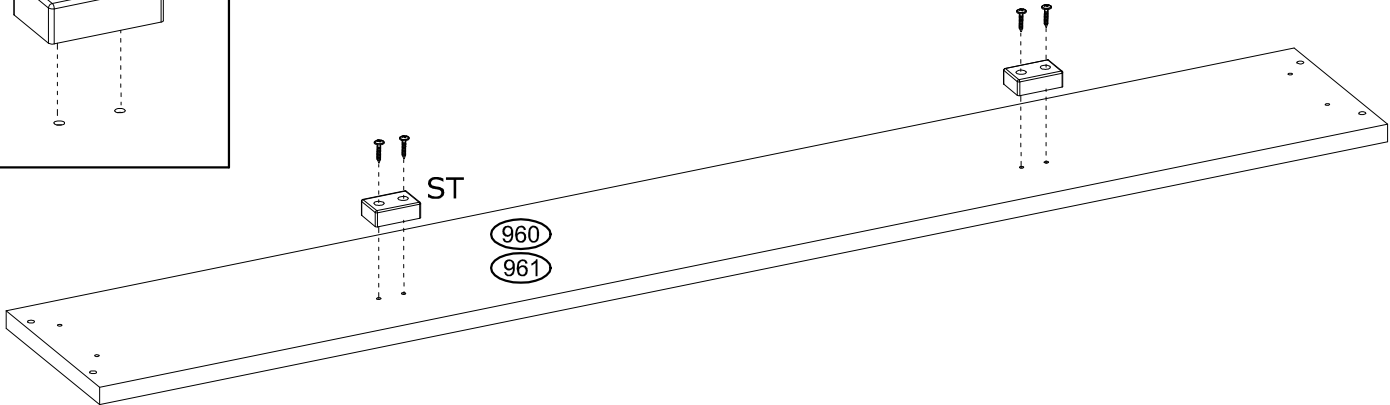
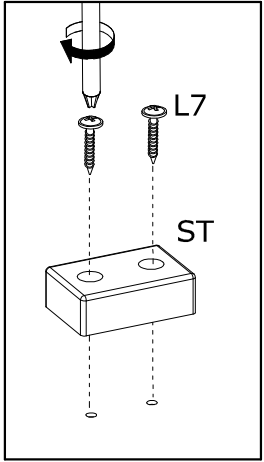

3

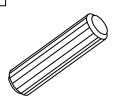
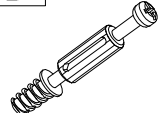
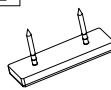
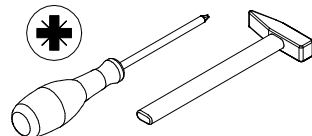
<p><b>A</b>    <math>\varnothing 8 \times 30</math> mm</p>  <p>x4 92597</p>	<p><b>B</b>    <math>\varnothing 6,5 \times 36,5</math> mm</p>  <p>x6 4066</p>	<p><b>Z2</b>    45x15x5 mm</p>  <p>x2 90907</p>	
---	--	---	--

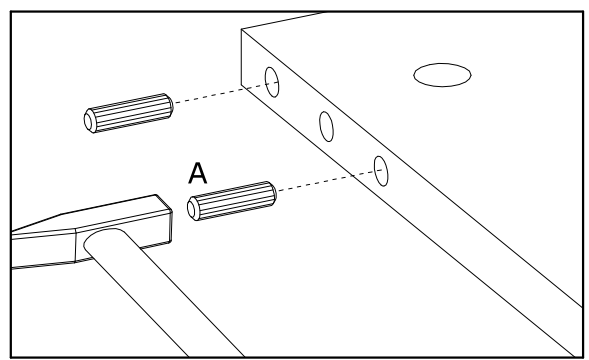
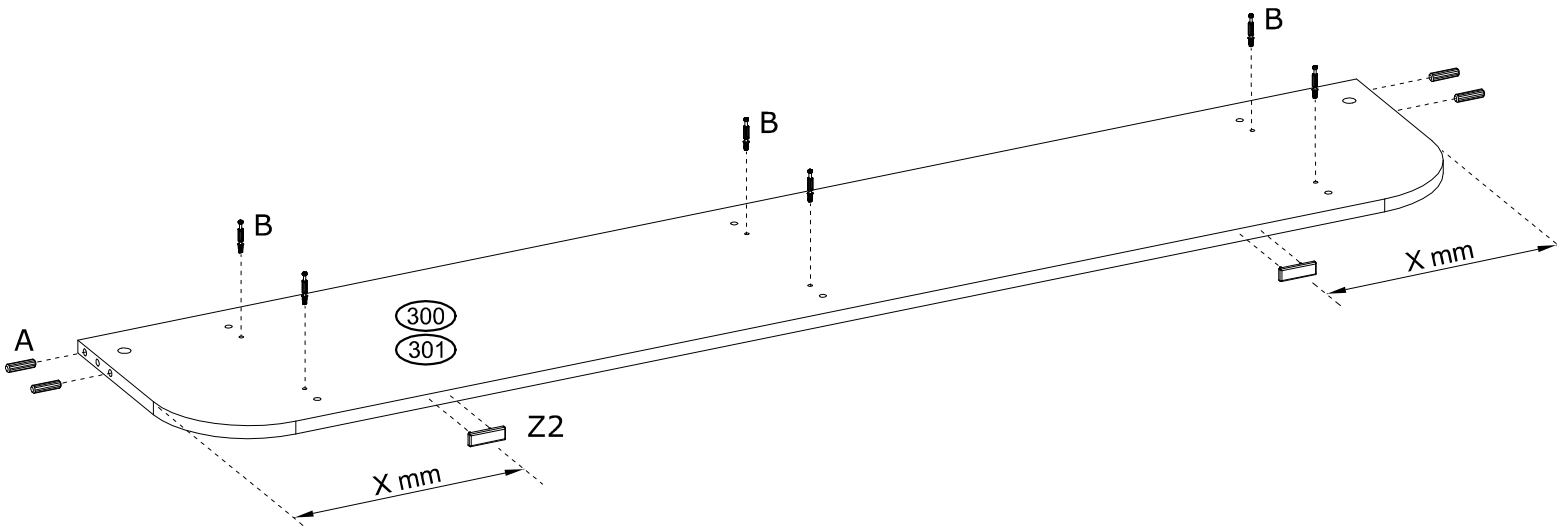

81 X = 490 mm  
82 X = 590 mm

4

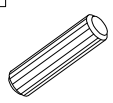
<p><b>A</b>    <math>\varnothing 8 \times 30</math> mm</p>  <p>x12 92597</p>	<p><b>Z2</b>    45x15x5 mm</p>  <p>x6 90907</p>	
---	--	---

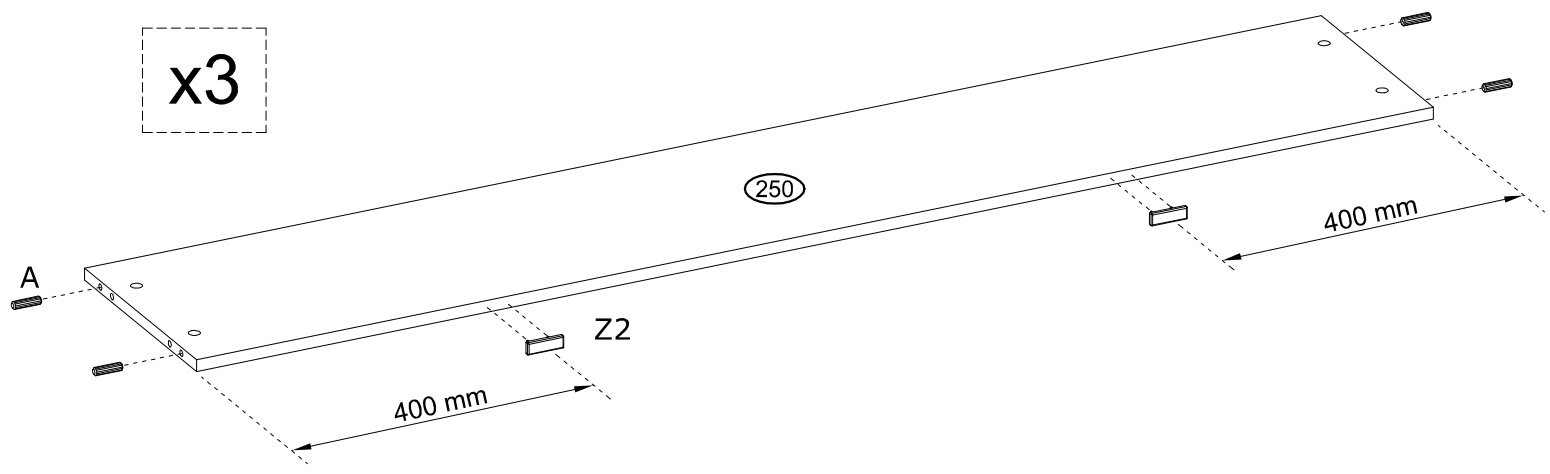

# 5

<b>A</b>	Ø8x30 mm x4 92597	<b>B</b>	Ø6,5x36,5 mm x1 4066	<b>K</b>	Ø3,5x16 mm x2 3918	<b>IM2</b>	6 mm	
<b>MU</b>	M6X17 mm x4 168986	<b>P1</b>	Ø6,3x13 mm x2 3880	<b>ZK</b>	128x30x23 mm x1 210474			

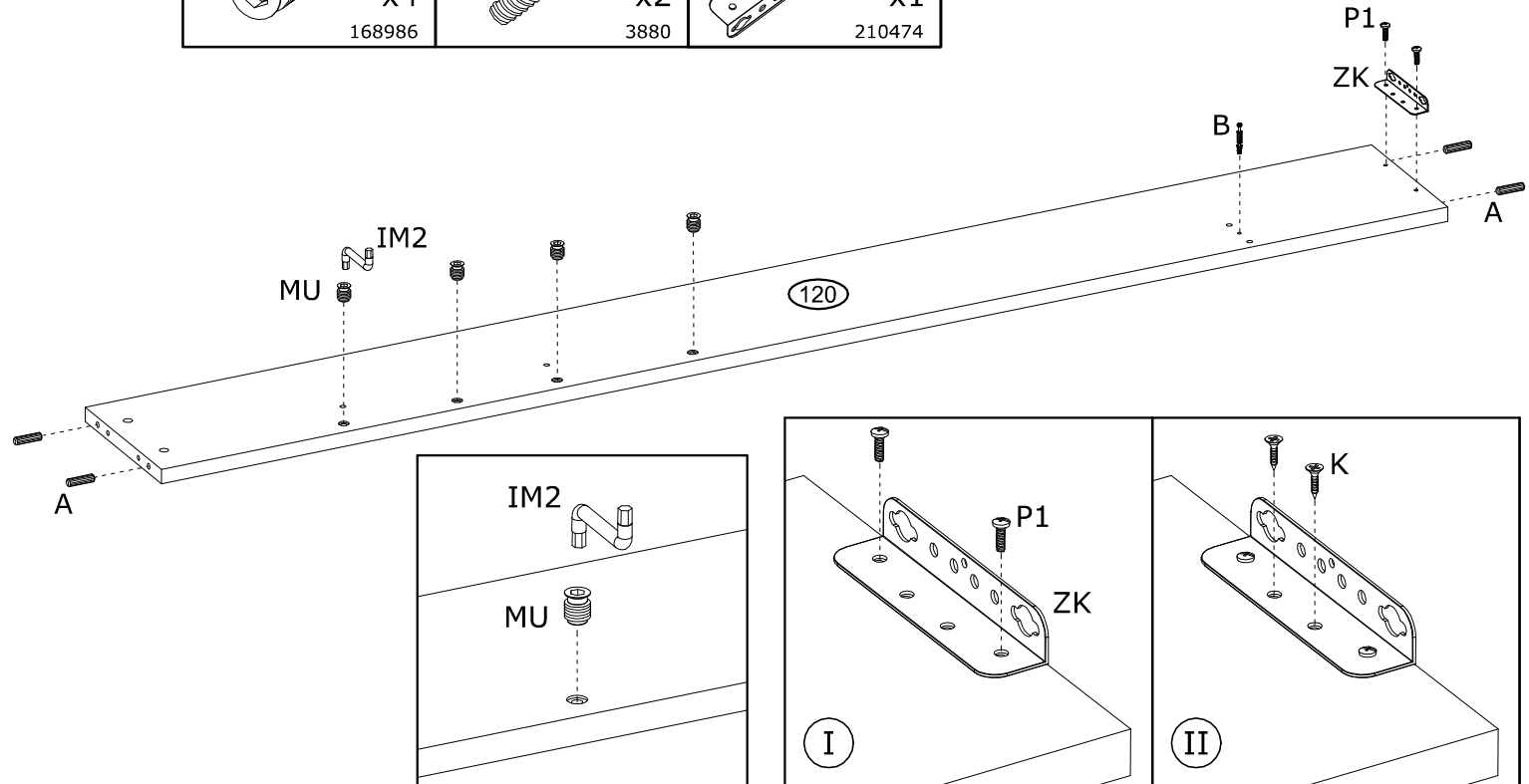

# 6

<b>A</b>	Ø8x30 mm x4 92597	<b>B</b>	Ø6,5x36,5 mm x1 4066	<b>K</b>	Ø3,5x16 mm x2 3918	<b>IM2</b>	6 mm	
<b>MU</b>	M6X17 mm x4 168986	<b>P1</b>	Ø6,3x13 mm x2 3880	<b>ZK</b>	128x30x23 mm x1 210474			

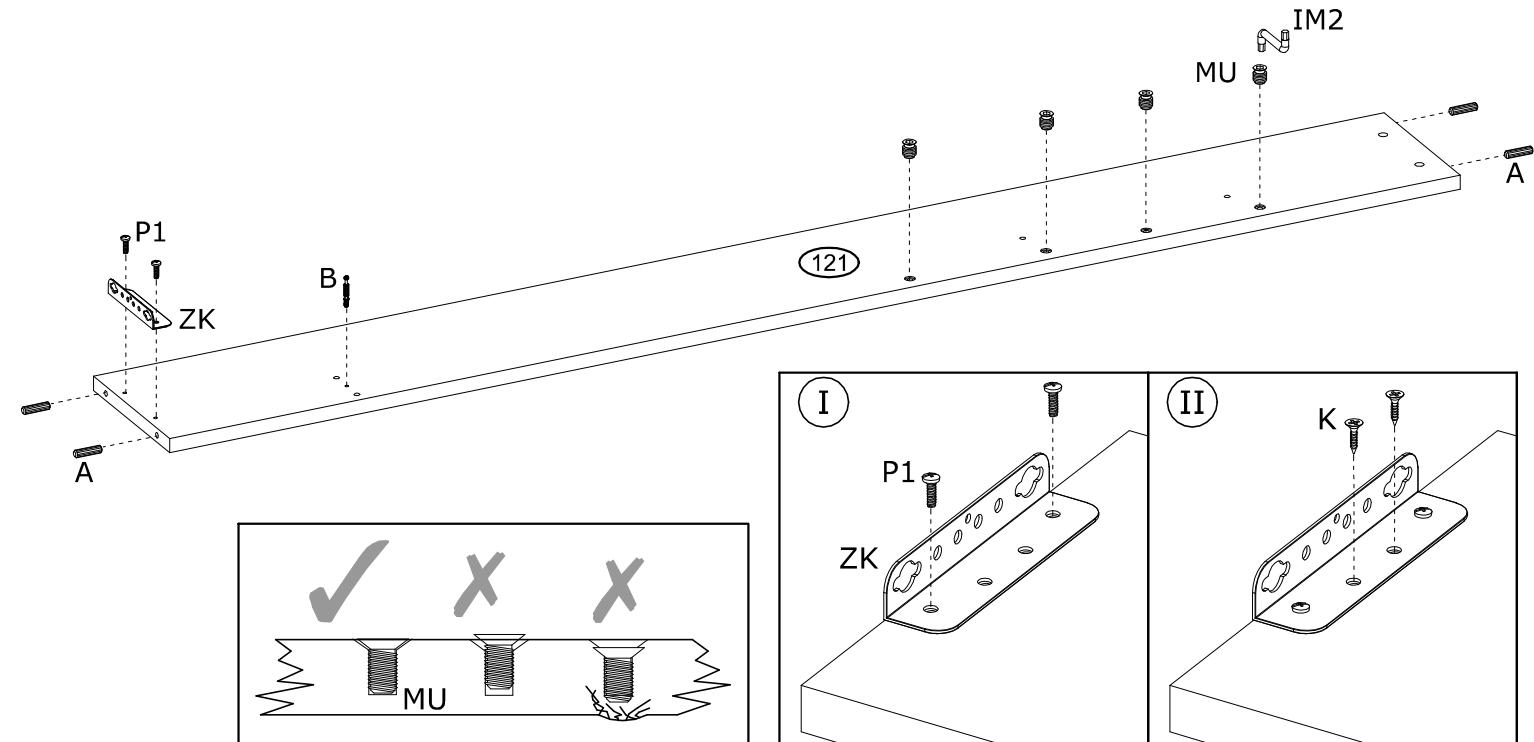



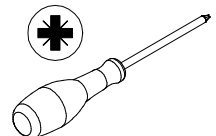

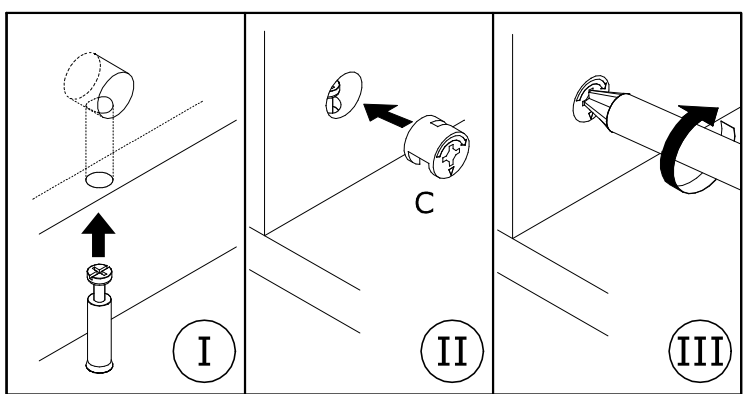
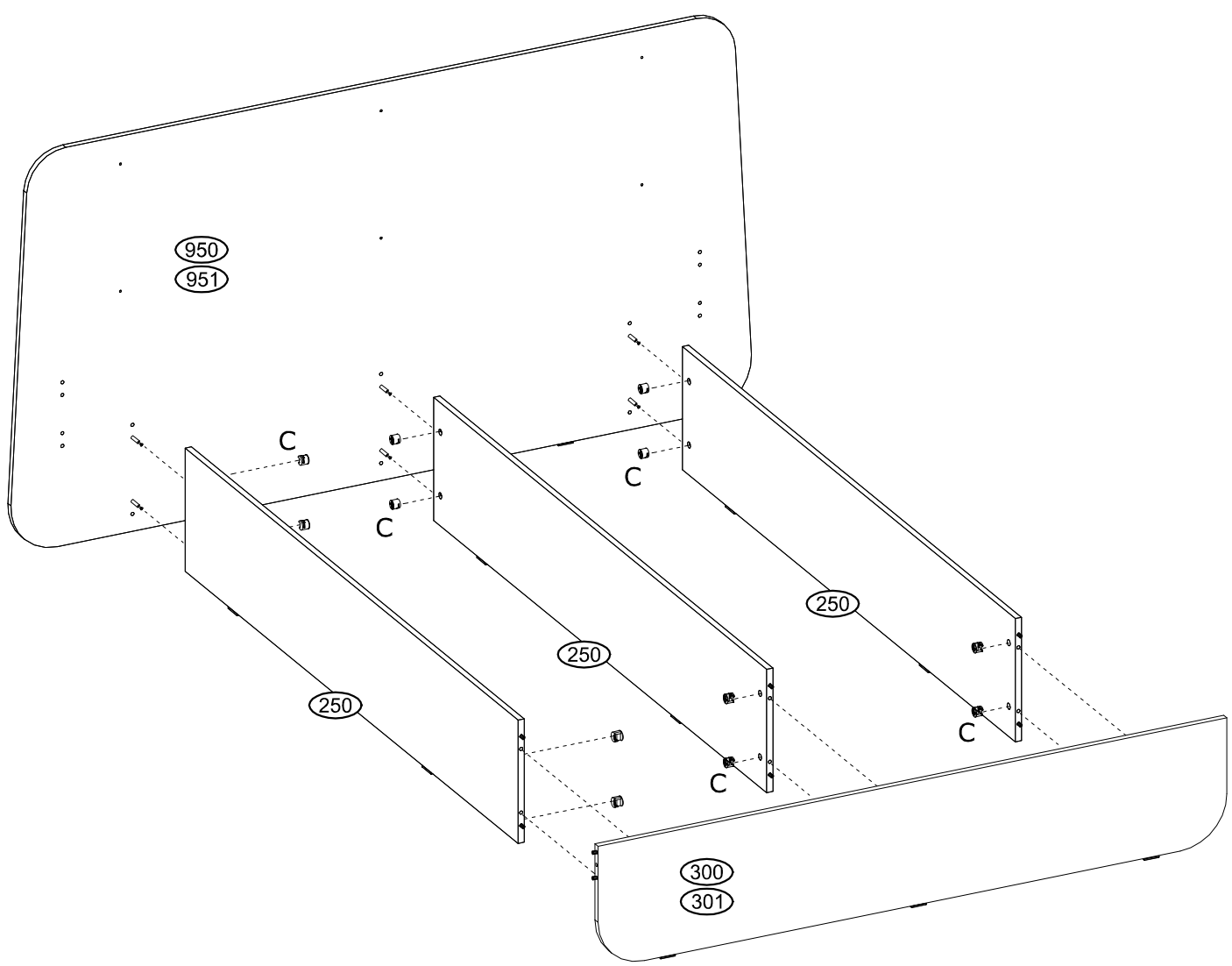

7

C	Ø15x12 mm x12 3996	
---	--------------------------	--

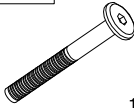

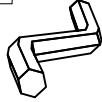
8

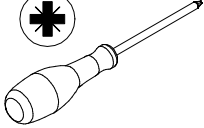
<b>C</b> Ø15x12 mm  x2 3996	<b>NW1</b> Ø10x16 mm  x4 3939	<b>WM2</b> M6,0x50 mm  x4 154328	 x2	<b>IM</b> 4 mm   
---	---	--	---	---

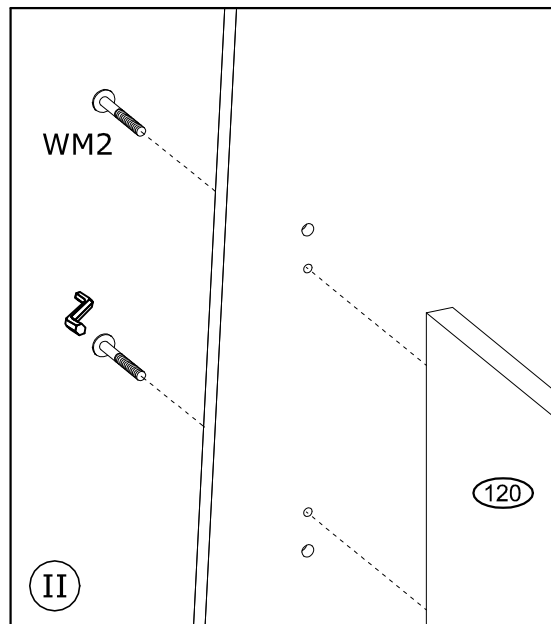
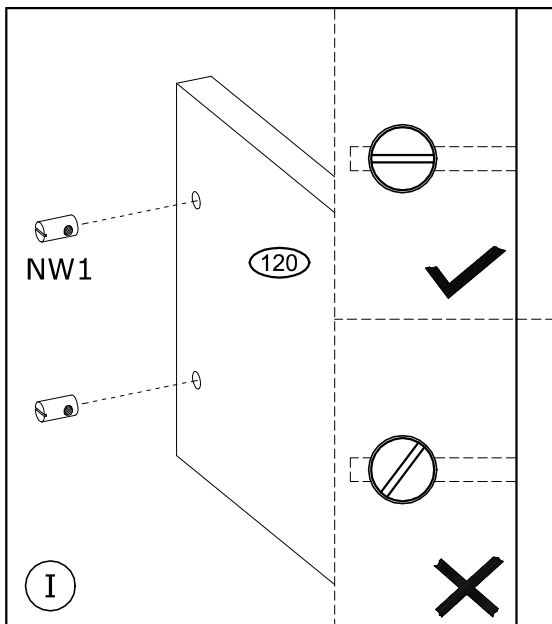
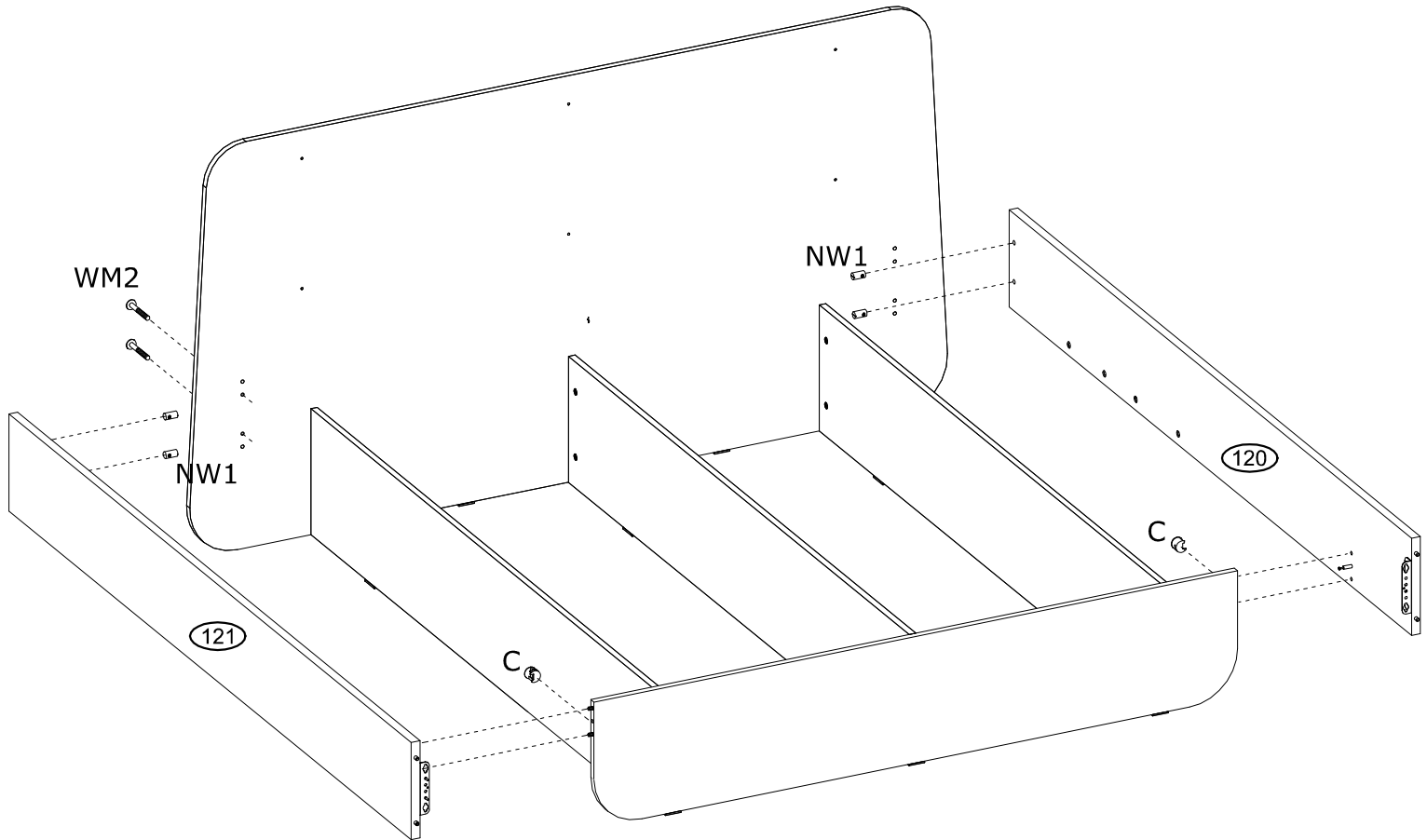
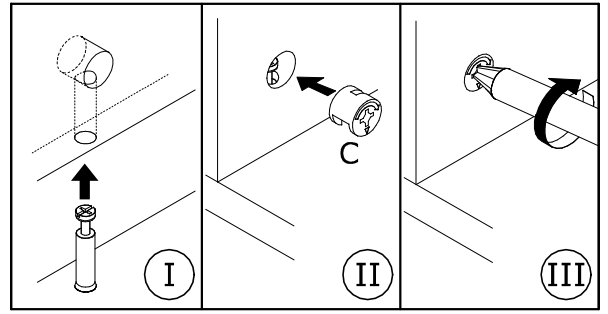

# 9

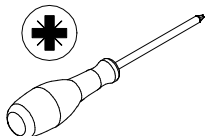
<b>K</b>	Ø3,5x16 mm	<b>P1</b>	Ø6,3x13 mm	<b>D</b>	Ø20 mm	
	x4 3918		x4 3880		x14 136239	

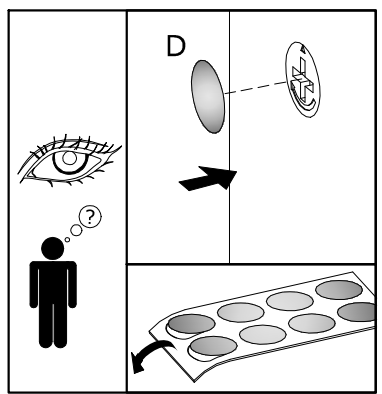
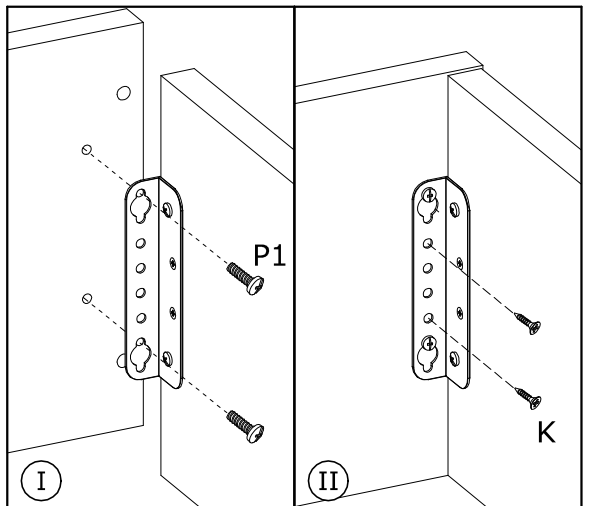
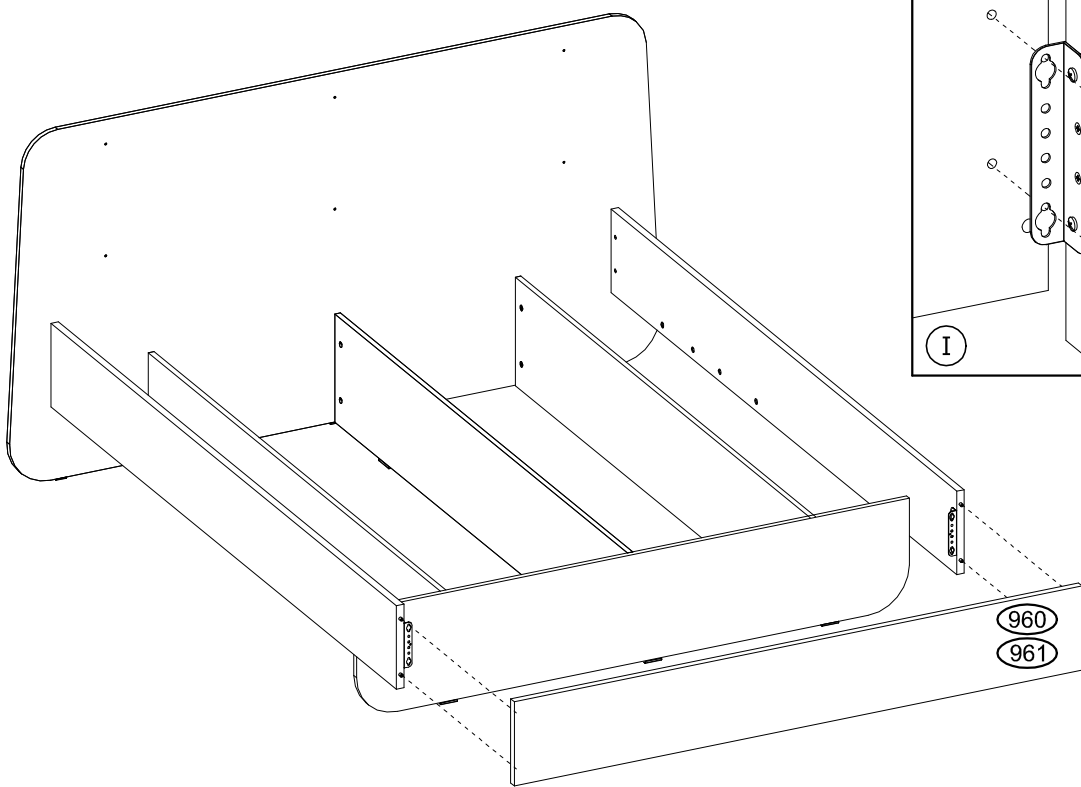

# 10

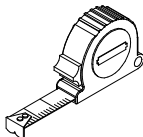
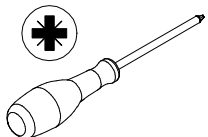
<b>L5</b>	Ø3,5x30 mm	 x2		
	x6 142372			

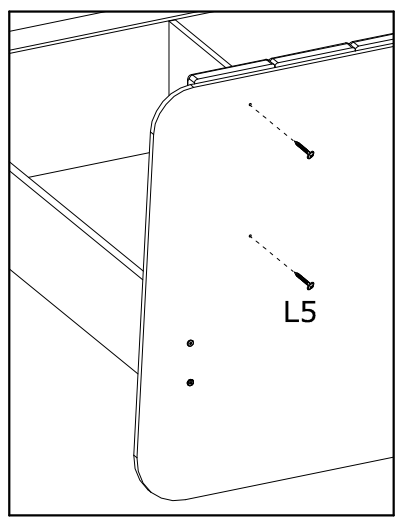
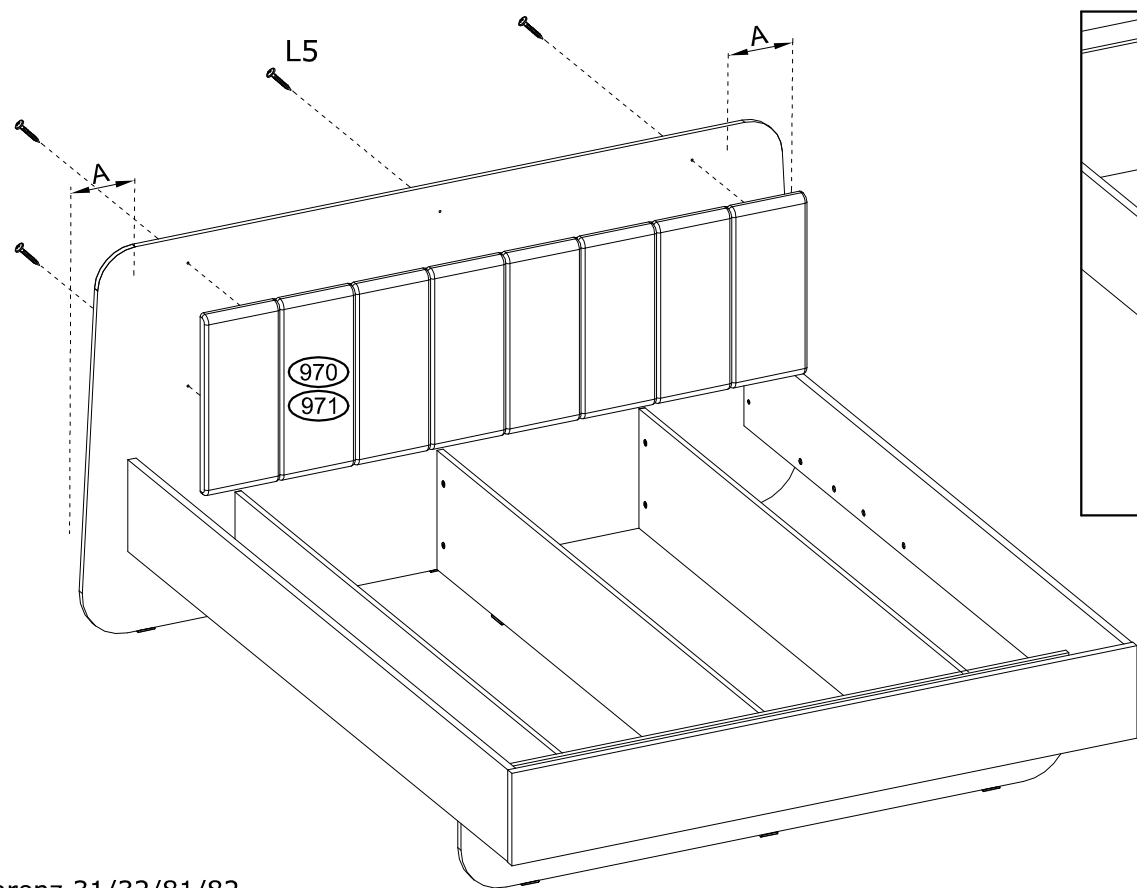

11

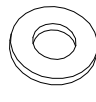
KA	M6x20 mm	PD	Ø8/Ø24-2 mm
	x8 261013		x8 3264

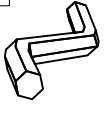
IM	4 mm
	

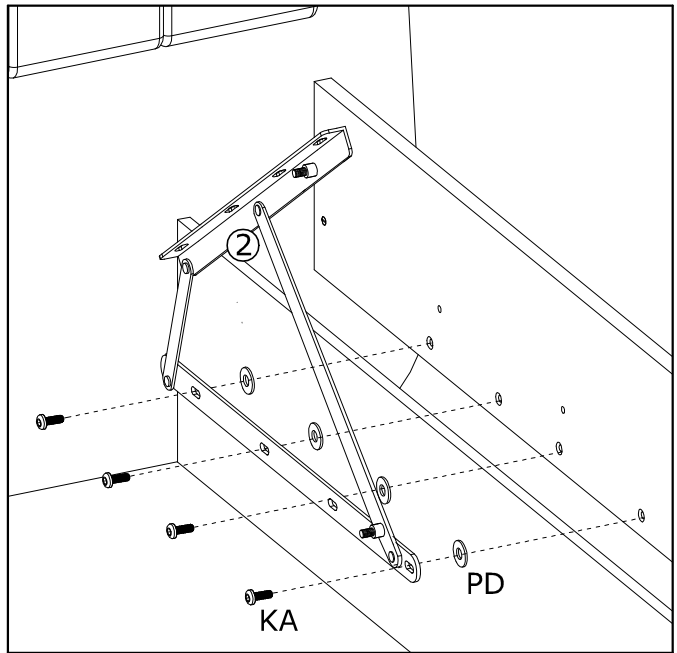
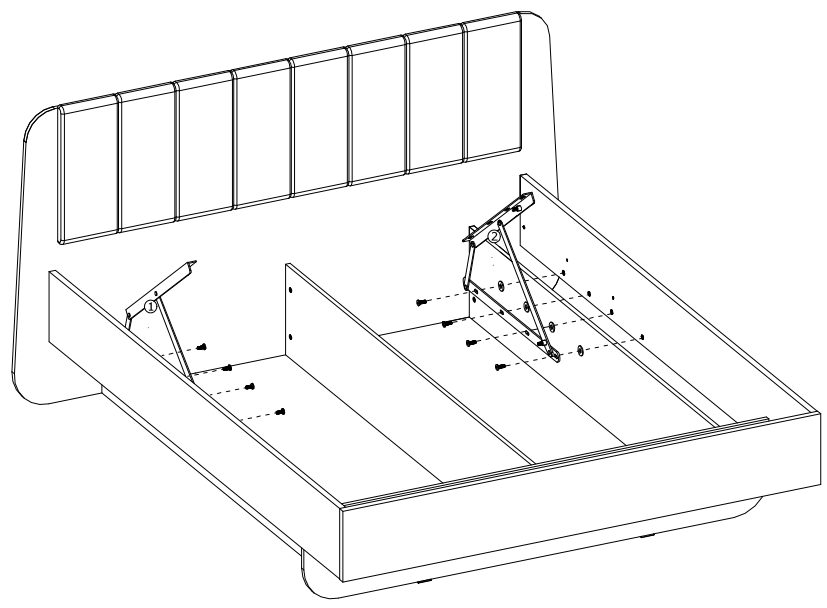

12

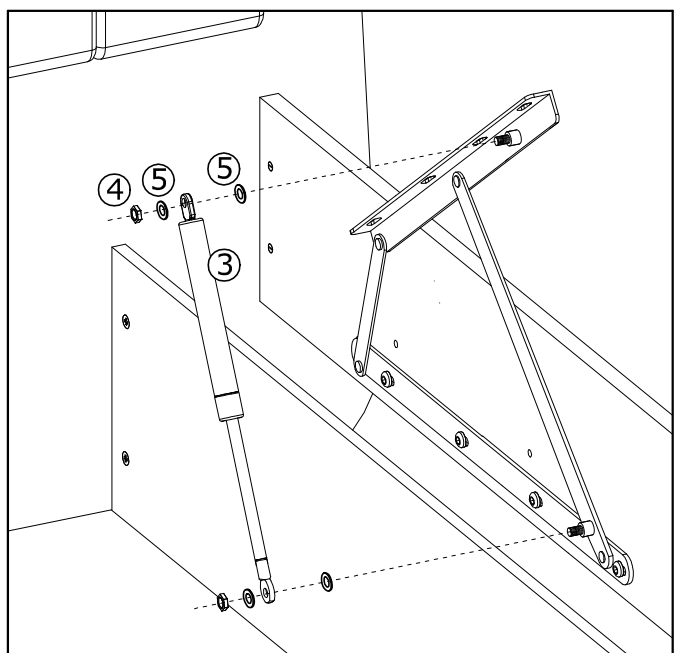
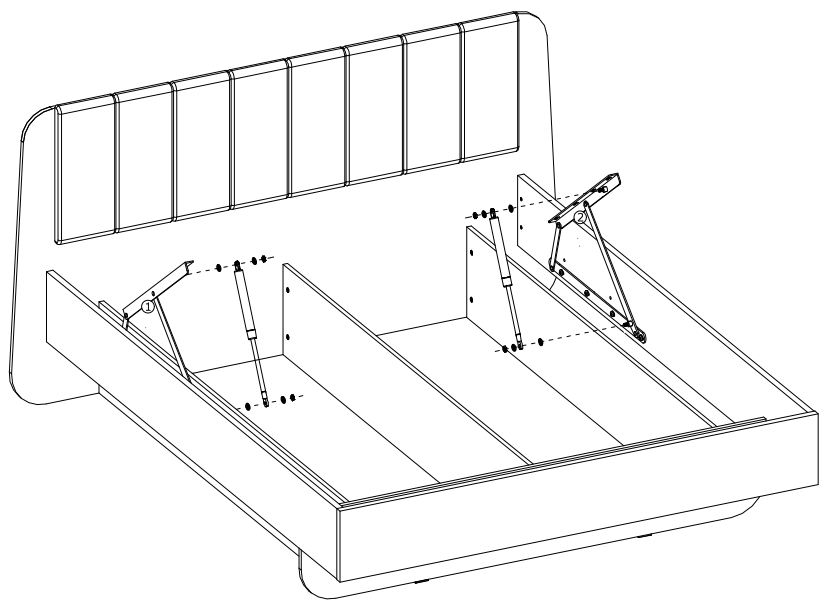

13

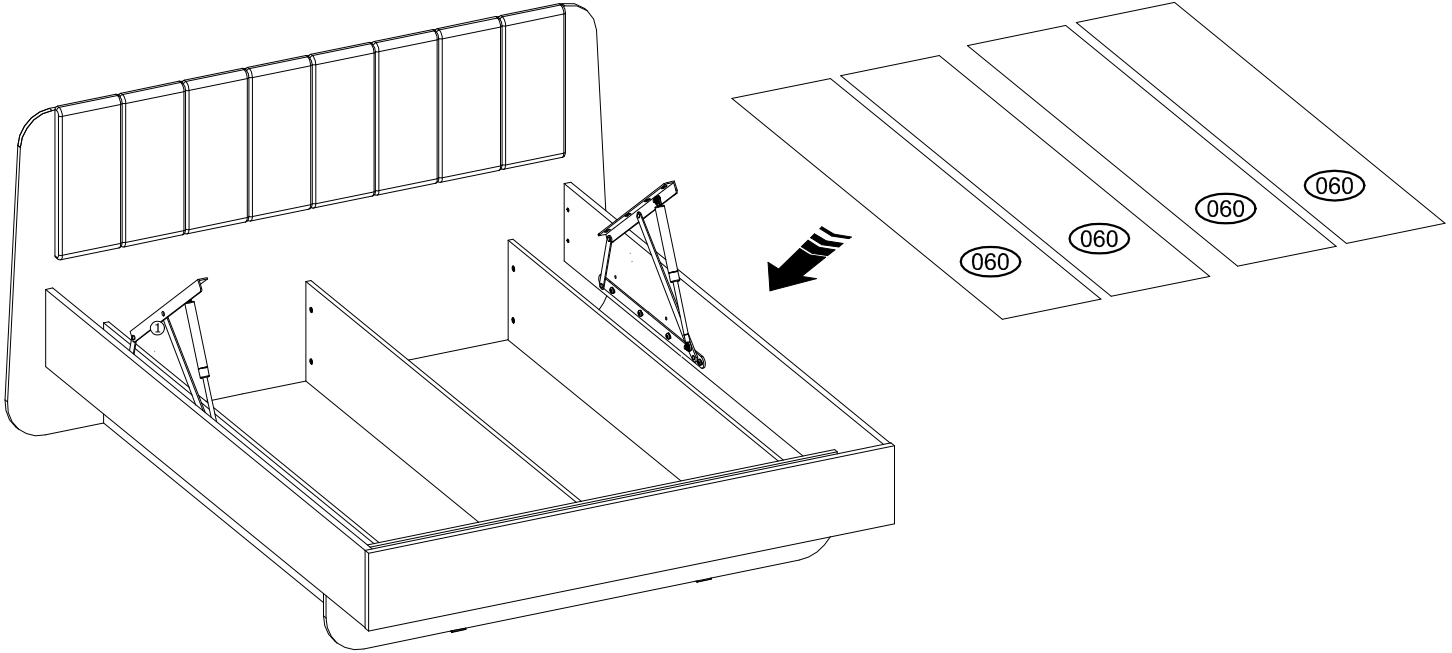

14

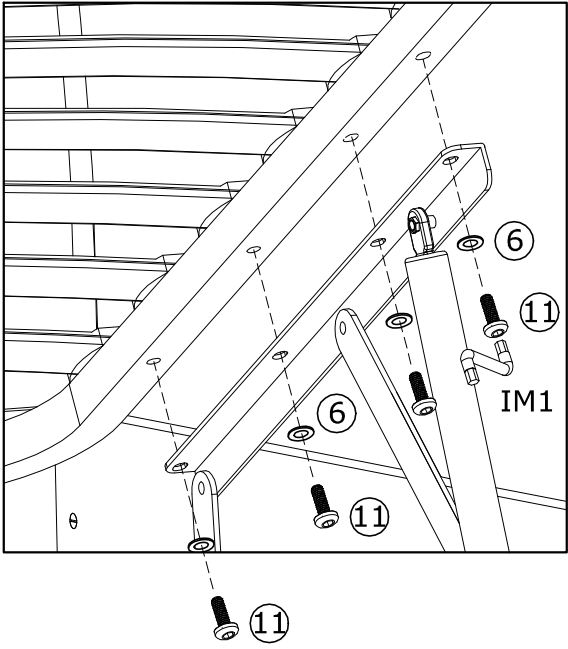
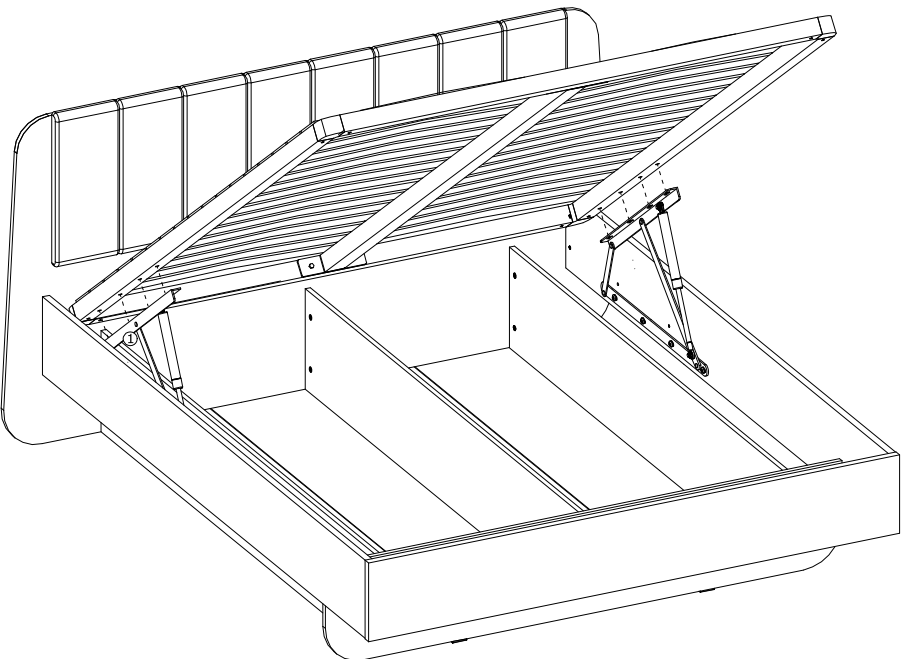

15

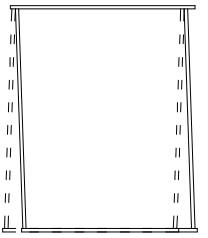
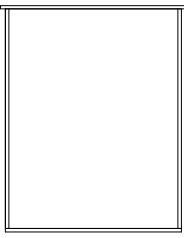
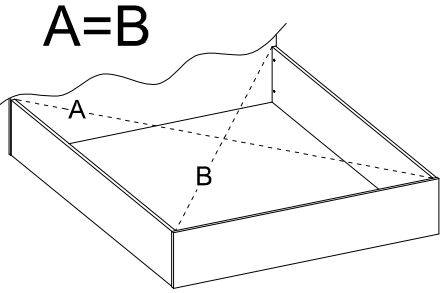
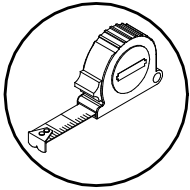
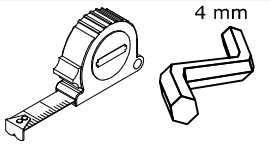

A=B

A≠B

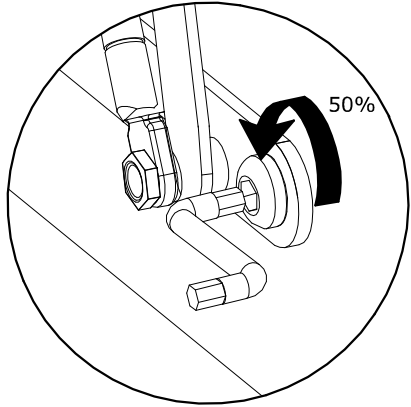

I

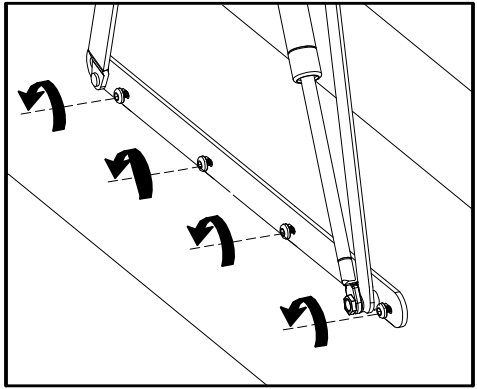

II

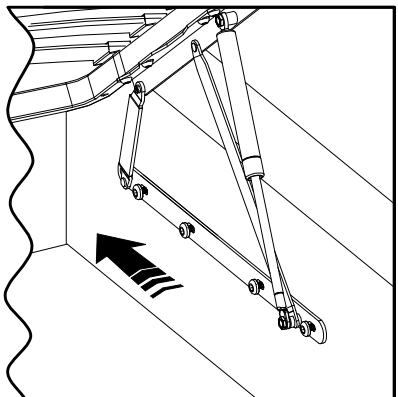
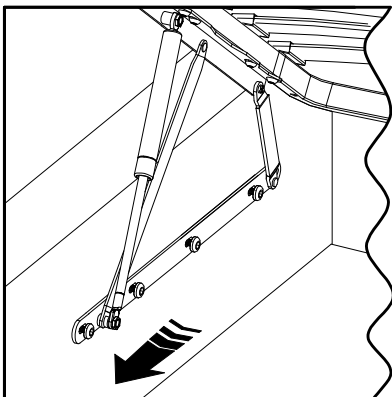
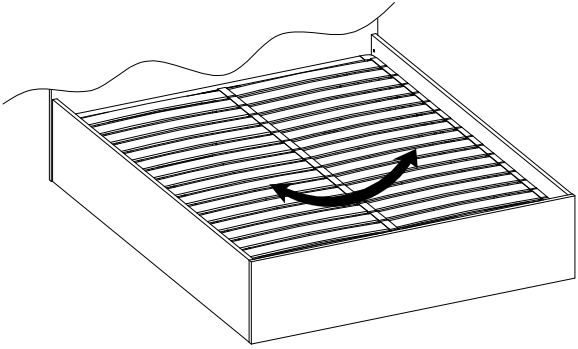
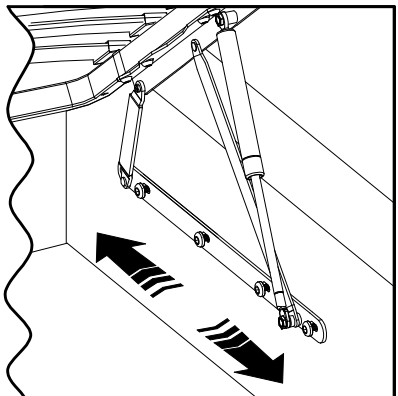
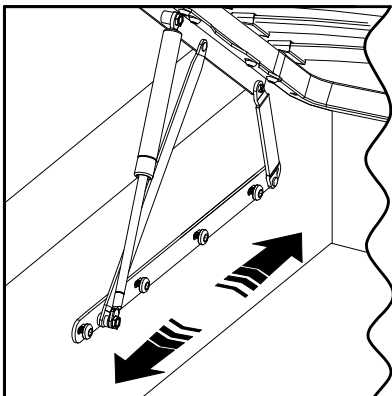
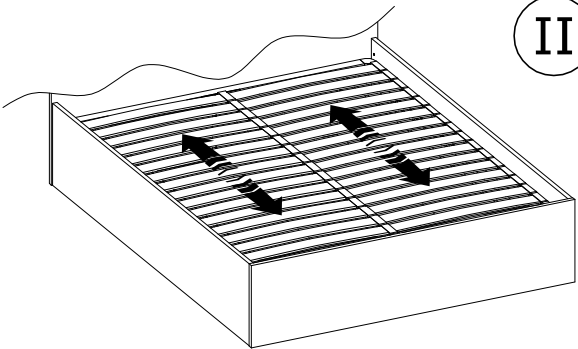

III

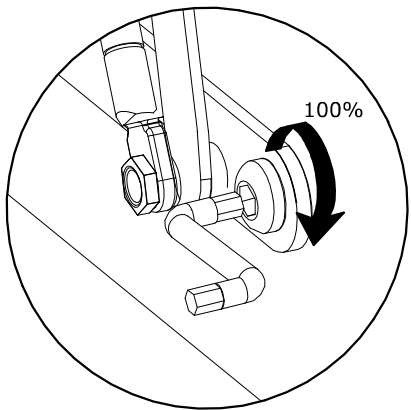
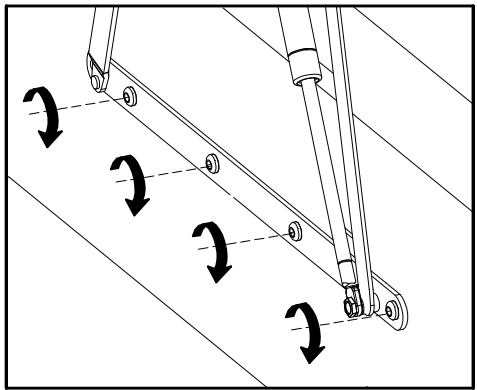

- D** Sicherheits- und Pflegehinweise
- FR** Conseils de sécurité et d'entretien
- NL** Veiligheids- en onderhoudstips
- CZ** Tipy pro bezpečnost a údržbu
- HU** Biztonsági és karbantartási tanácsok
- TR** Güvenlik ve bakım ipuçları
- ES** Instruções de segurança e manutenção
- SRB** Савети за безбедност и одржавање
- SL** Nasveti za varnost in vzdrževanje
- LV** Drošības un apkopes padomi

- GB** Safety and maintenance tips
- IT** Consigli per la sicurezza e la manutenzione
- PL** Wskazówki dotyczące bezpieczeństwa i konserwacji
- SK** Tipy na bezpečnosť a údržbu
- RO** Sfaturi de siguranță și întreținere
- RU** Советы по безопасности и обслуживанию
- PT** Instruções de segurança e manutenção
- HR** Savjeti za sigurnost i održavanje
- LT** Saugos ir priežiūros patarimai
- EE** Ohutus- ja hooldusnõuanded

