

PL Instrukcja montażu
CZ Instrukce k instalaci
D Montageanleitung
GB Assembly instruction
F Midel d'emploi
HU Szerelési útmutató
I Istruzione di montaggio
NL Handleiding voor de montage
RU Инструкция по установке
RO Instructiuni de instalare
SK Návod na inštaláciu
TR Montaj talimati
SE Montering instruktion
SLO Navodila za namestitev
HR Upute za sastavljanje

MONTÁŽNÍ/MONTÁŽNY NÁVOD LAIMA

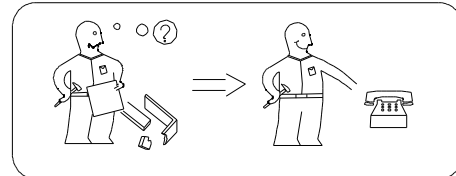

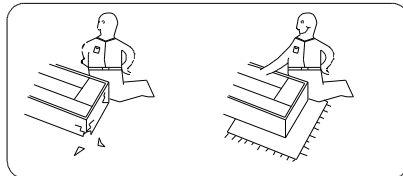

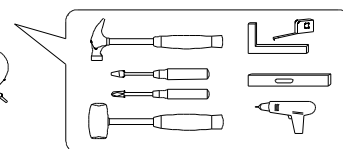
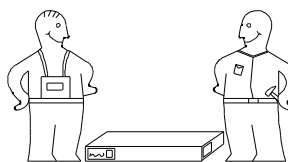

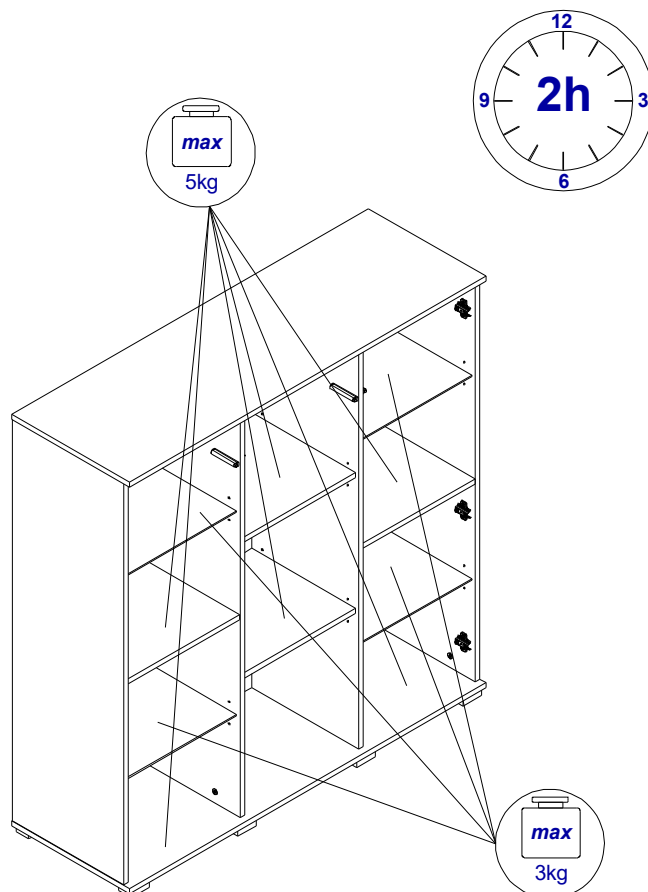
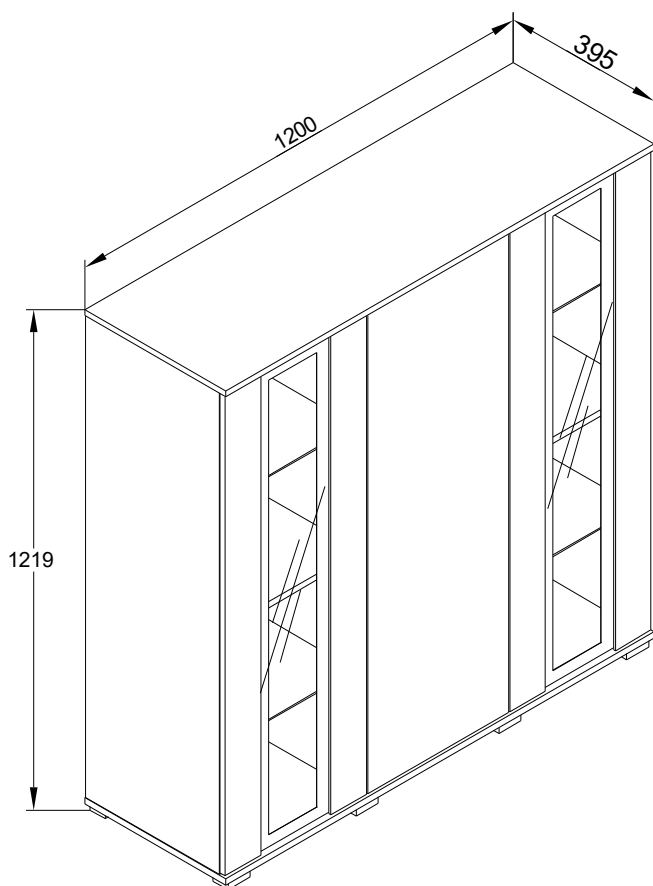

! Uwaga . Upozornini. Achtung . Attention . Caution . Firyelem . Attenzione . Opgelet . внимание .
 Atentie . Upozornenie . Dikkat . Uppmärksamhet . Uppmärksamhet . Pozor . Pažnja **!**







PL	Czyszczenie należy wykonywać wyłącznie za pomocą ściereczki lekko nawilżonego ręcznika. nie stosować środków ów czyszczących do szorowania.	I	La pulizia deve essere eseguita solo con un panno e un asciugamano leggermente inumidito. non utilizzare agenti abrasivi.
CZ	Čištění í by se mělo provádět pouze hadř íkem a mírn ě navlhčným ručníkem. nepou žívejte abrazivní prostředky.	NL	Reinig alleen met een stofdoek of lichtjes met een vochtige doek. Gebruik geen schurende of bijtende poetsmiddelen.
D	Bitte nur mit einem Staubtuch oder leicht feuchtem Lappen reinigen. Keine scheuernden Putzmittel verwenden.	RU	Чистку следует производить только тряпкой, слегка смоченной полотенцем. не используйте чистящие средства.
GB	Please only clean with a duster or a damp cloth. Do no use any abrasive cleaners.	RO	Curatare trebuie efectuată numai cu o carpa sau cu un prosop usor umezit. Nu utilizati agenti de curatare abrazivi.
F	Le nettoyage doit être effectué uniquement avec un chiffon, une serviette légèrement humidifiée. n'utilisez pas d'agents à récurer.	SK	Čistenie by sa malo uskutočňovať iba pomocou handričky a mierne navlhčen ěho uteráka. nepou žívaťe drsné prostriedky.
HU	A tisztítást csak ruhával, enyhén megnedvesített törölköz övel szabad elvégezni. ne használjon tisztítószert a súroláshoz.	TR	Temizlik sadece bezle, hafif çe nemlendirilmi ş havluyla yapılmalıdır. ovma maddeleri kullanmayın.
SE	Torka rent med en fuktig trasa. Använd endast vatten eller ett mild rengöringsmedel. Torka torrt med en ren trasa.	SLO	Obrišite z vlažno krpo. Uporabljajte le vodo ali blag detergent. Posušite s čisto krpo.
HR	Očistite vlažnom krpom. Upotrijebite samo vodu ili blagi deterđent. Posušite čistom krpom.		





I-III

						
L	S	A	B	D	PS	S3
x9	x8	x8	x16	x16	x3	x16

IV-VI

						
H14	M	A	D	B	H8	ZD1
x16	x8	x16	x8	x8	x12	x6

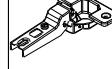

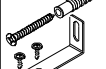

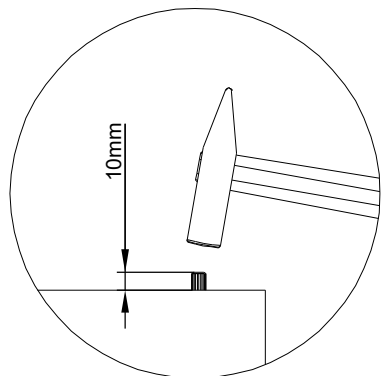
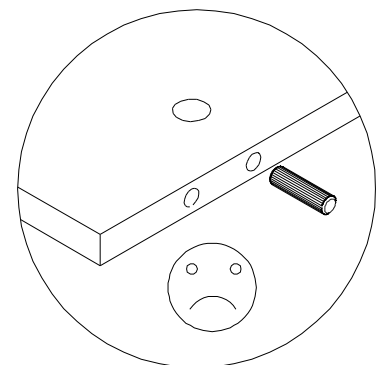
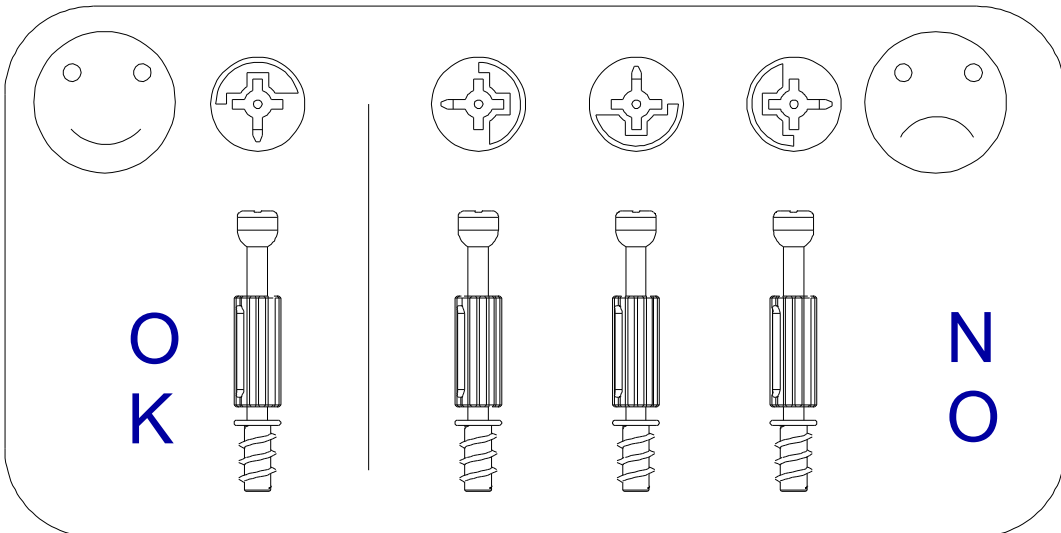
VII-XV

				
H8	ZD2	I	X3	KM
x6	x3	x24	x24	x2

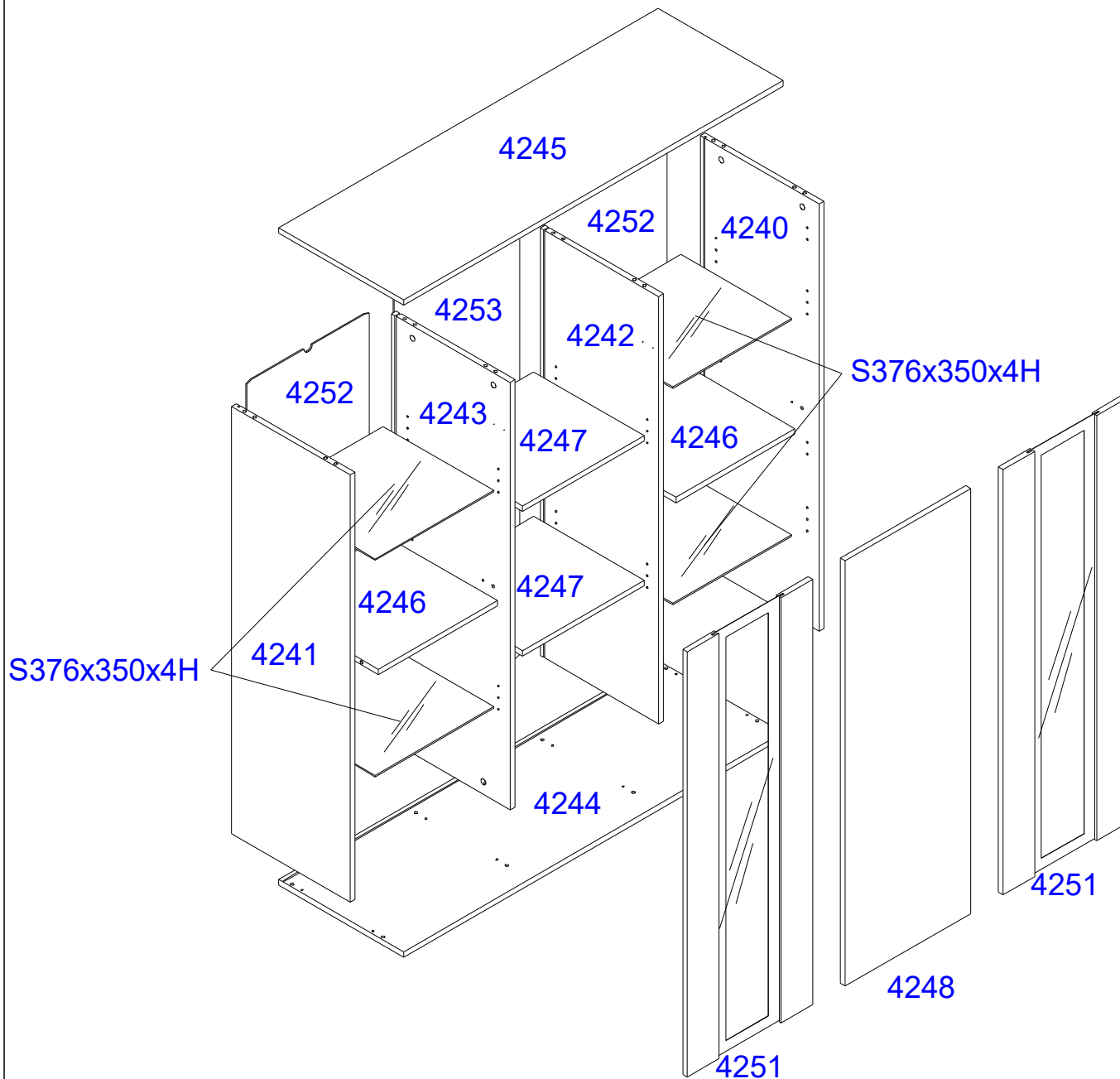
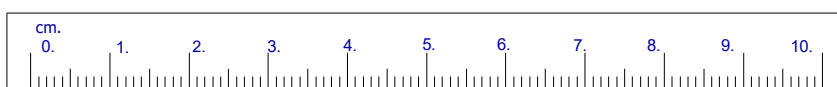
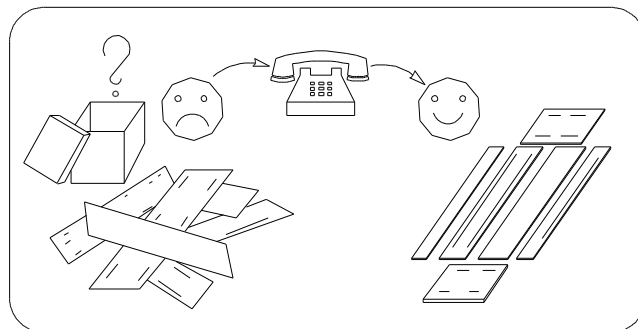
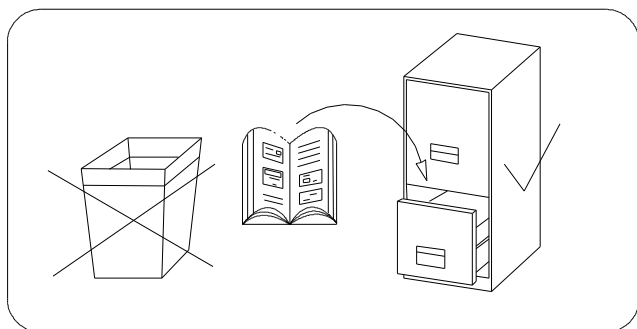

Karta serwisowa . Servisní list Service . Karte Service card . Carte de service . Szervizkártya
Scheda di servizio . Service kaart . Сервисная карта . Fisa service . Servisný list . Servis karti
servicekort . servisno kartico . servisa kartica



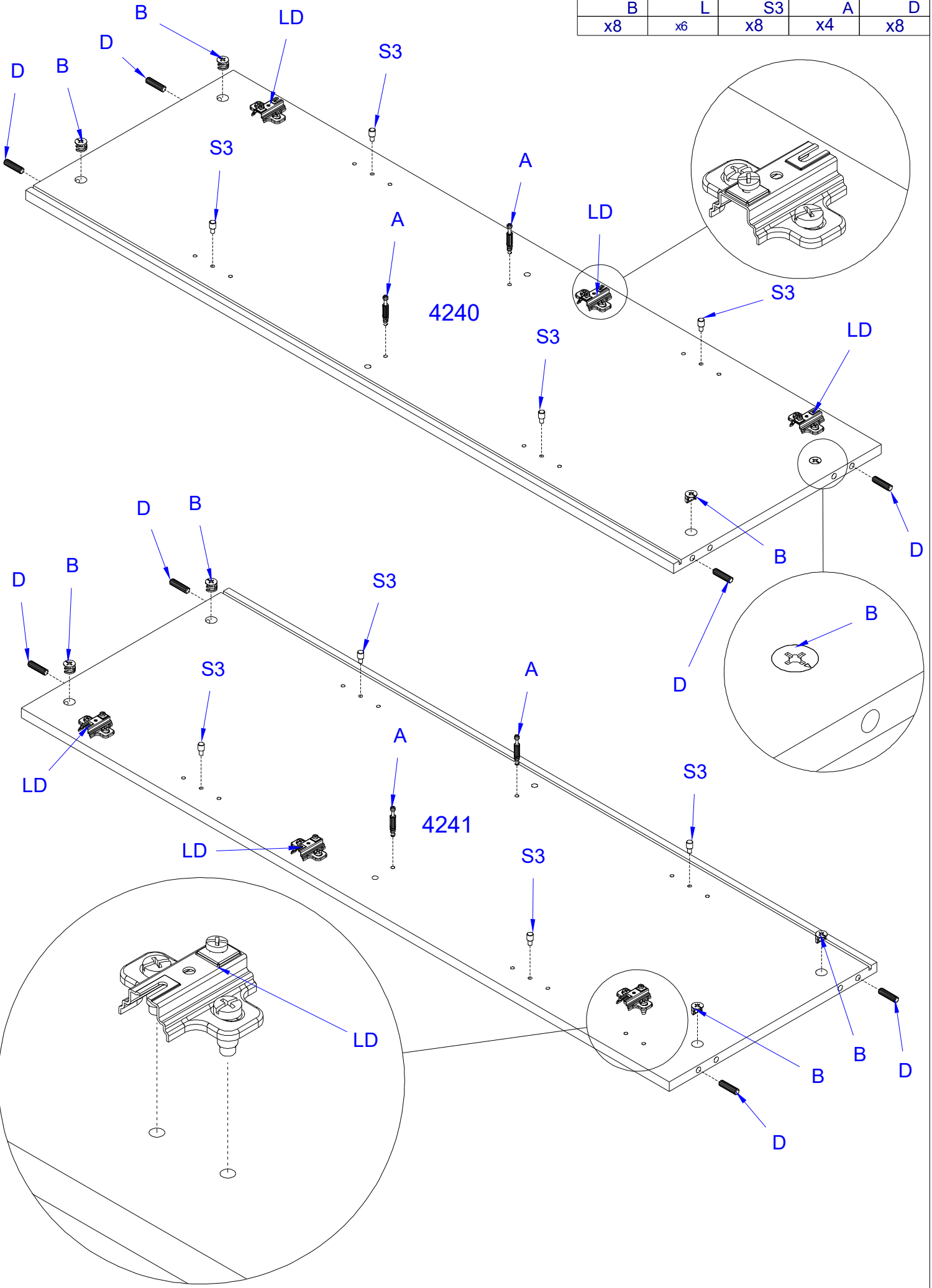

				
B	L	S3	A	D
x8	x6	x8	x4	x8

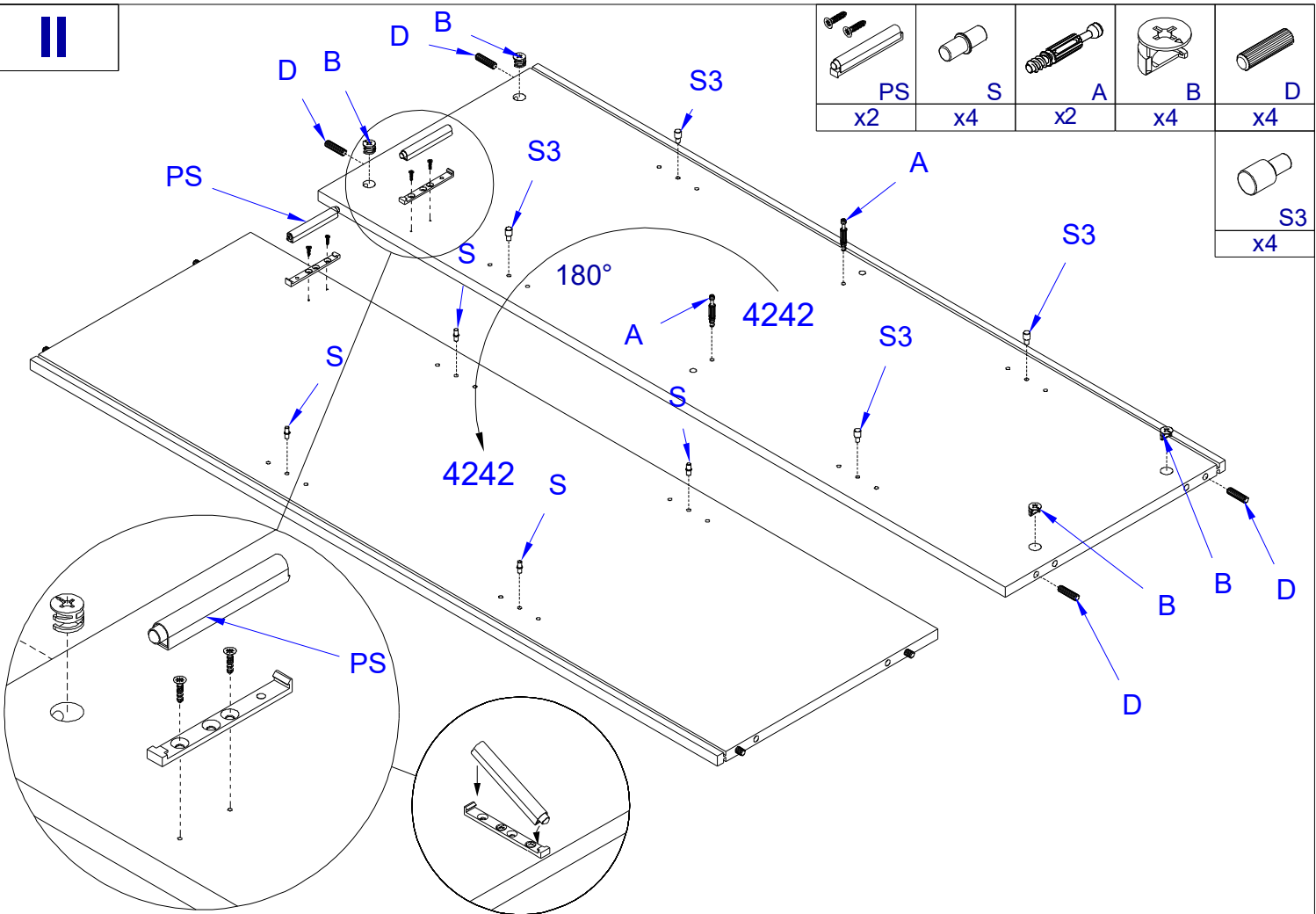
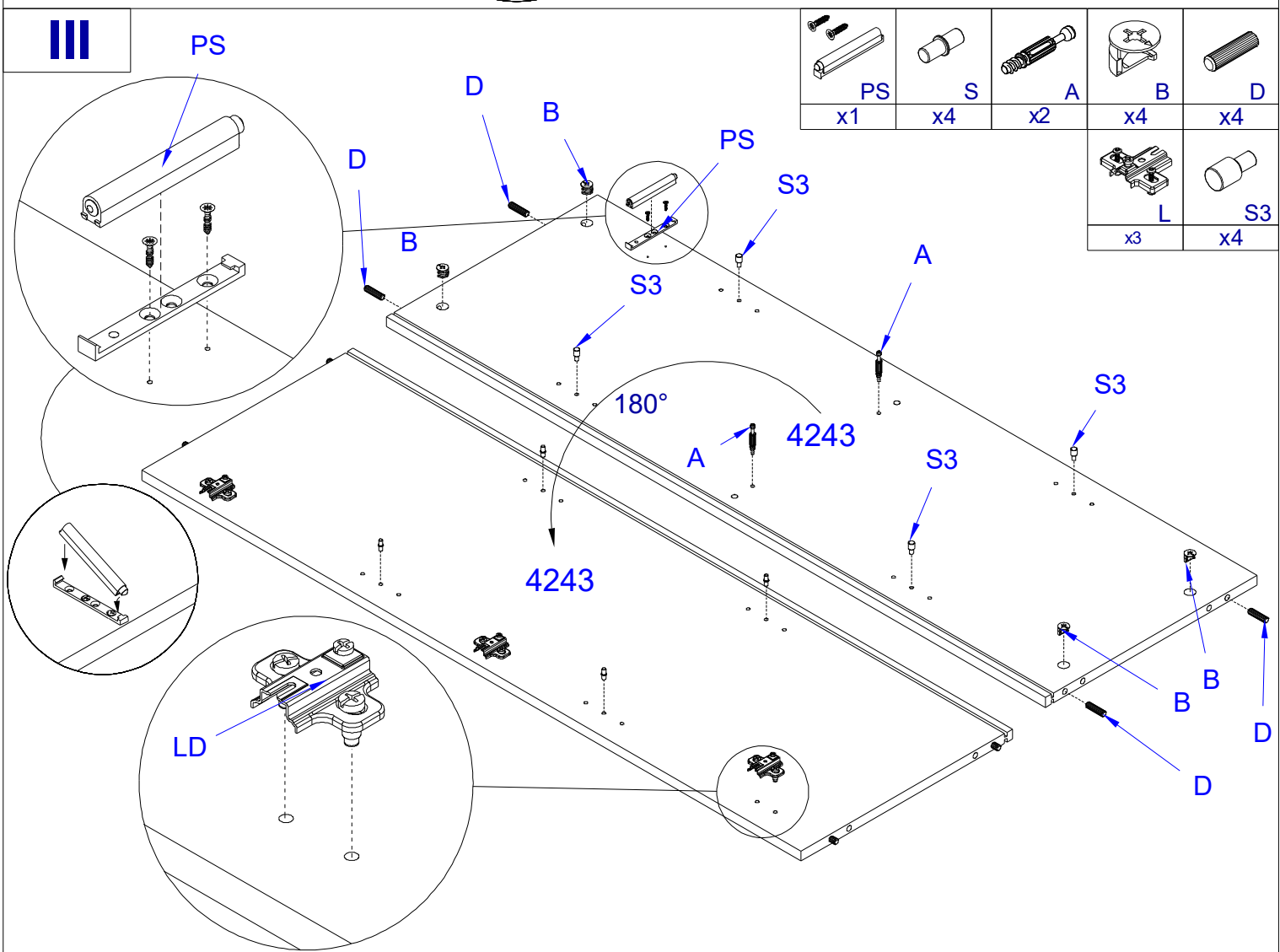



II**III**

IV

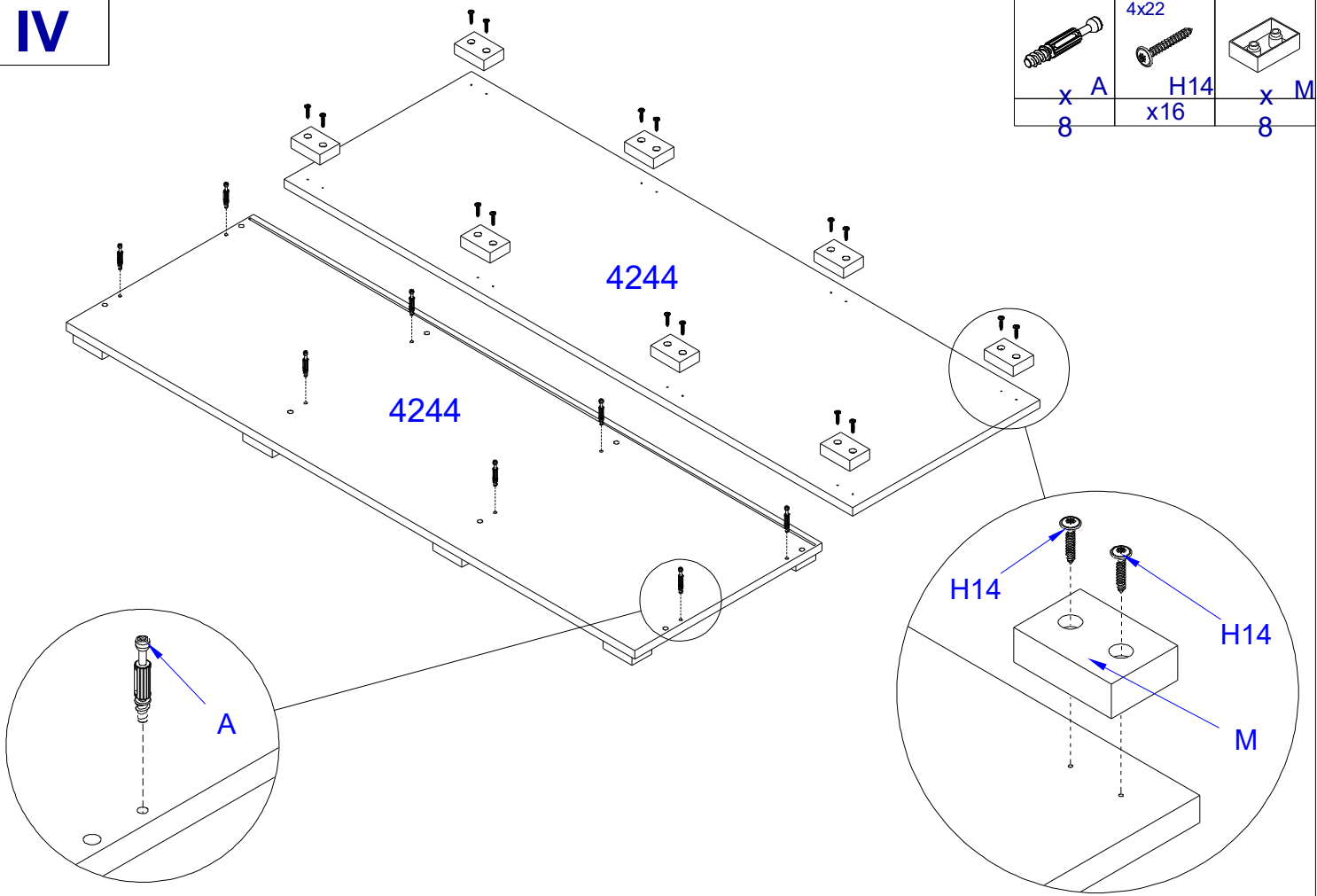
	4x22		
x 8	A	H14 x16	x M



V

		
x 8	D	B

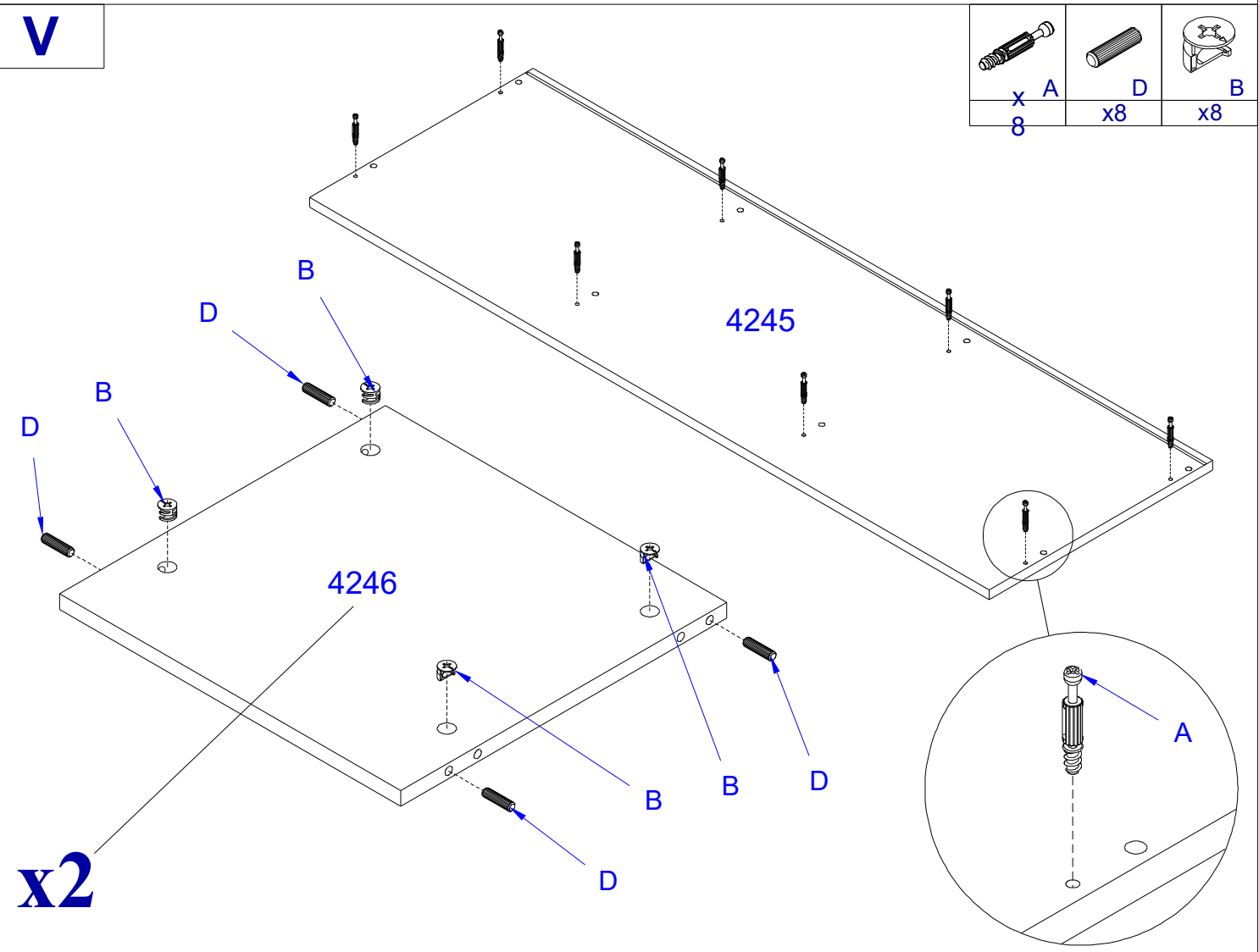

VI

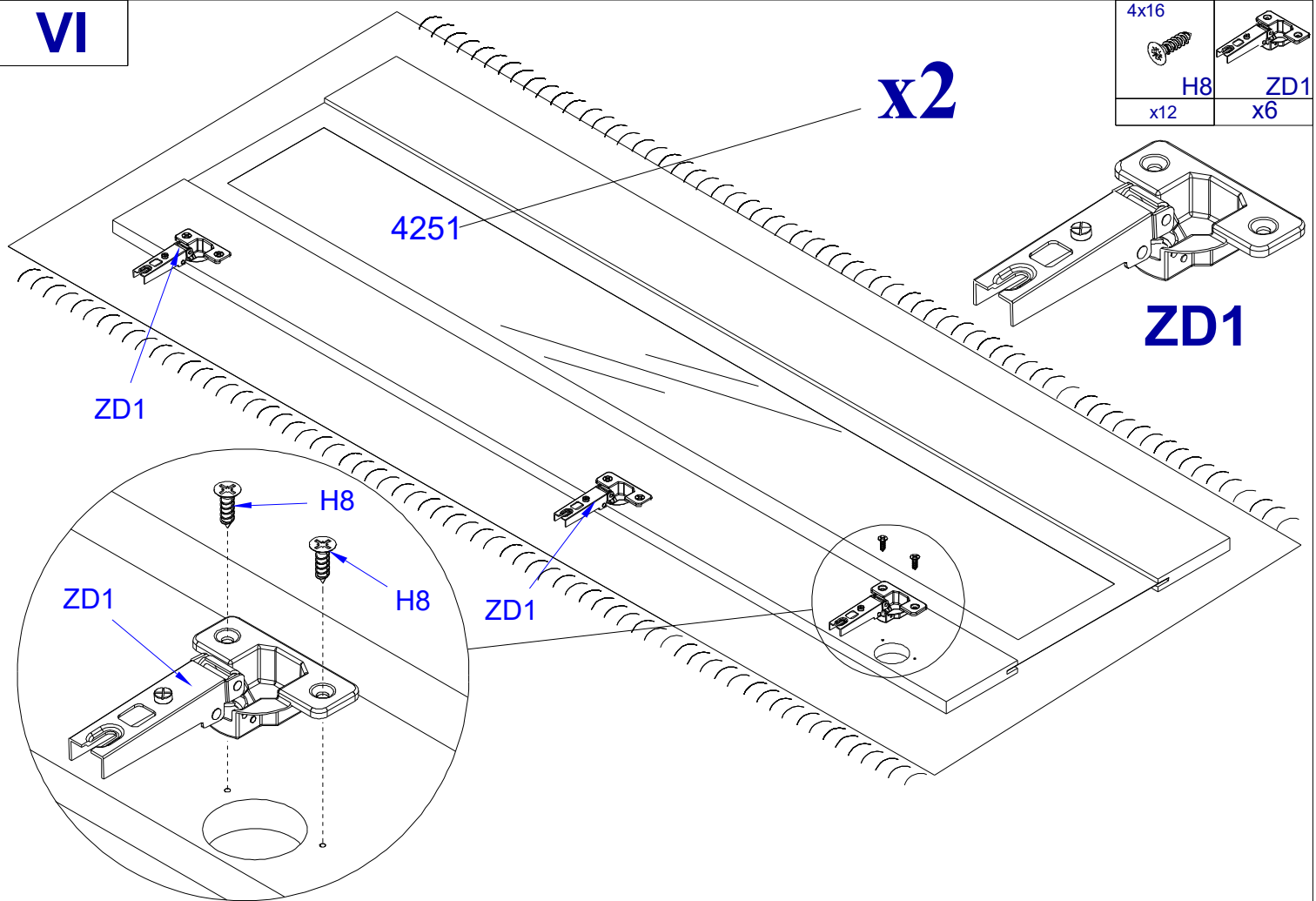

VII

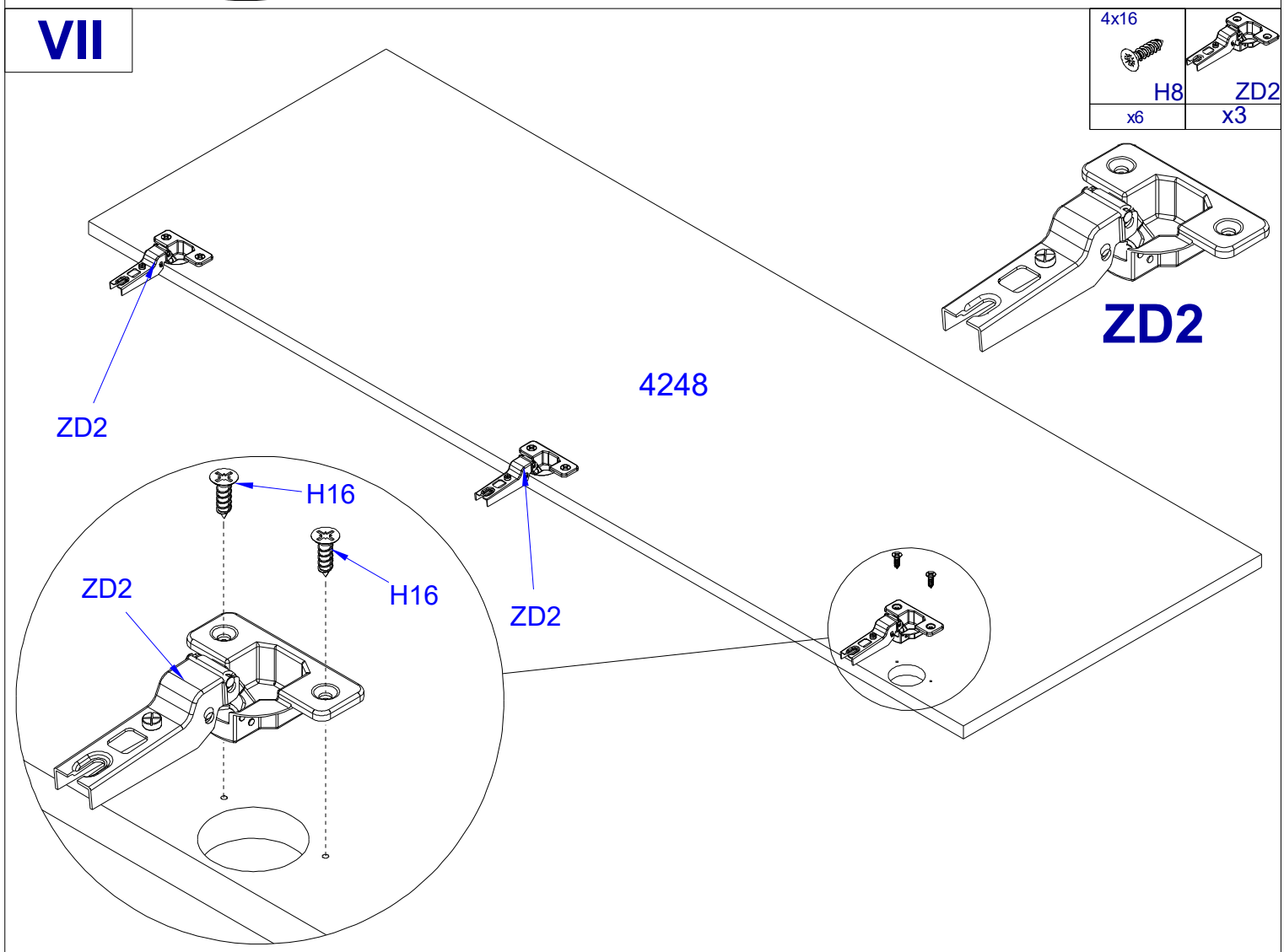

VIII

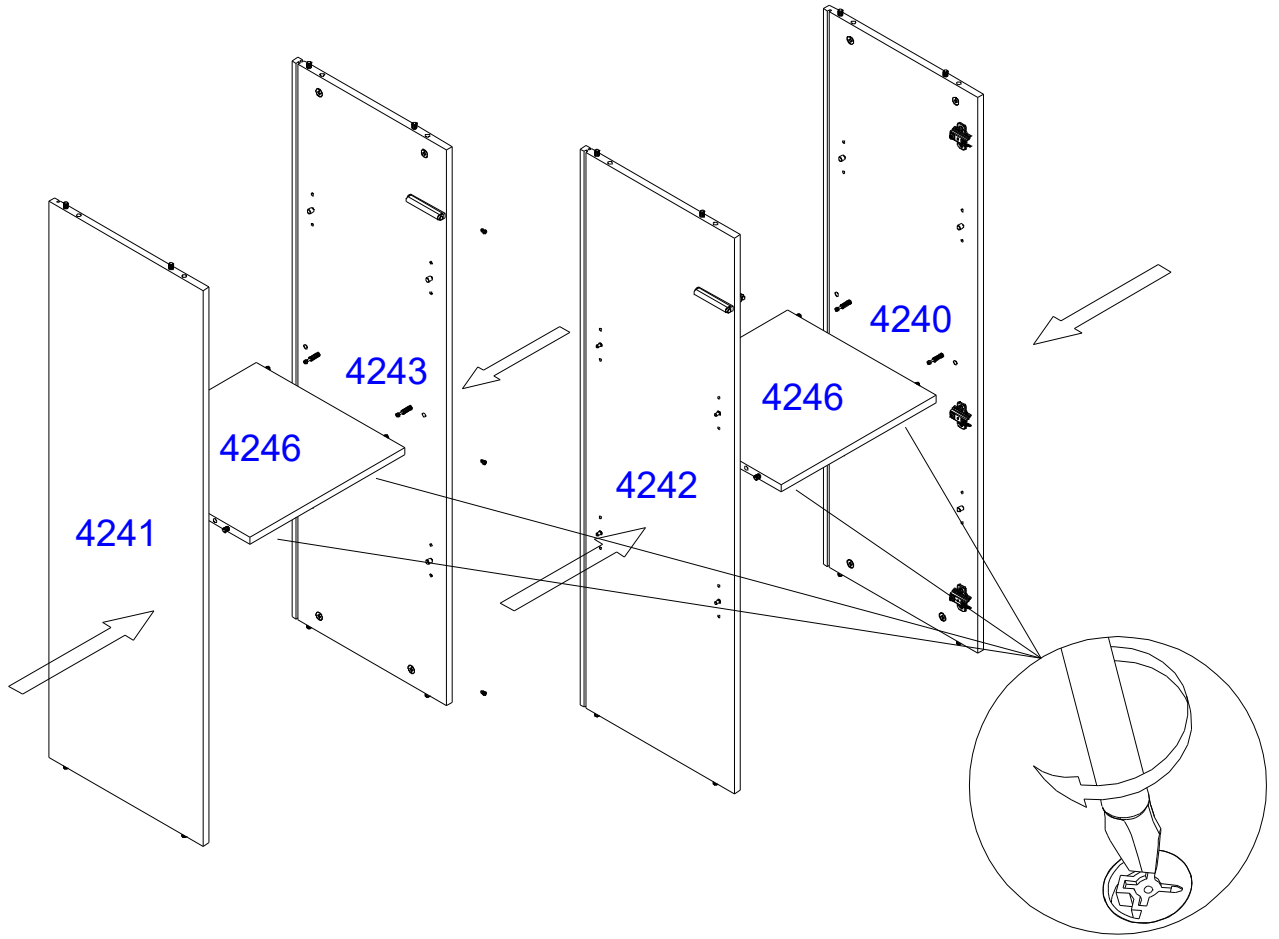

IX

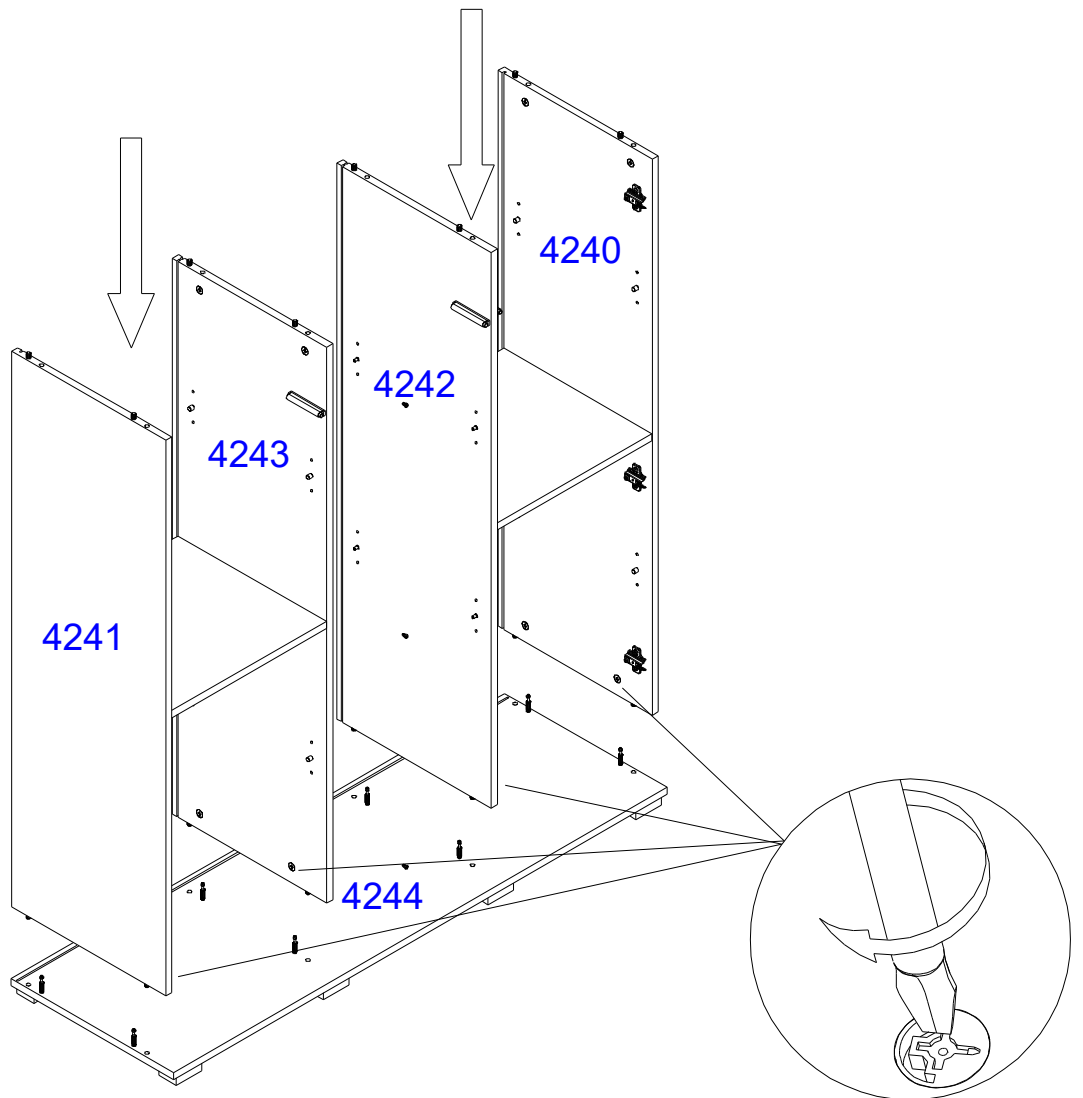

X

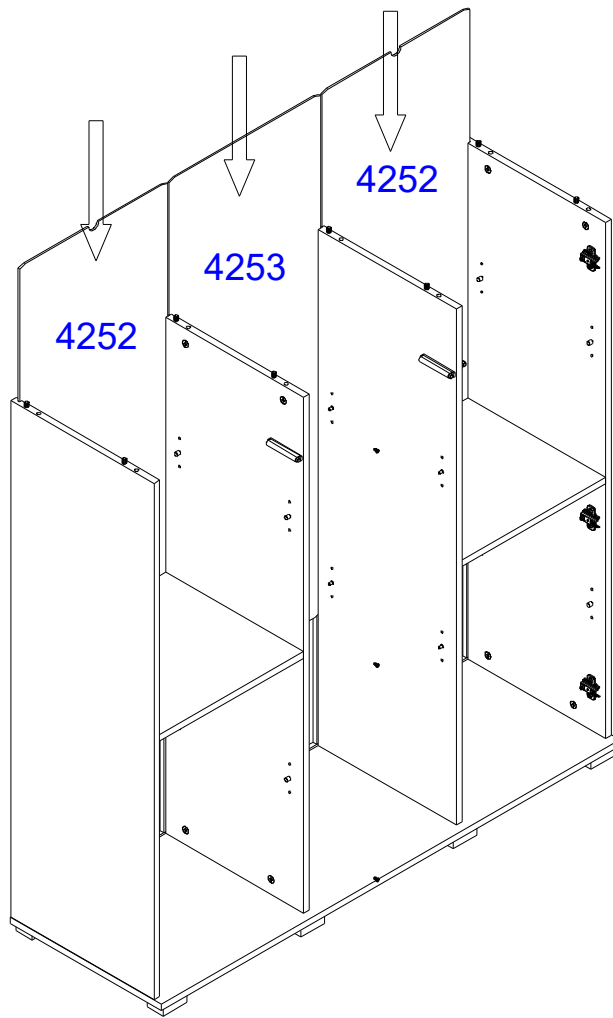

XI

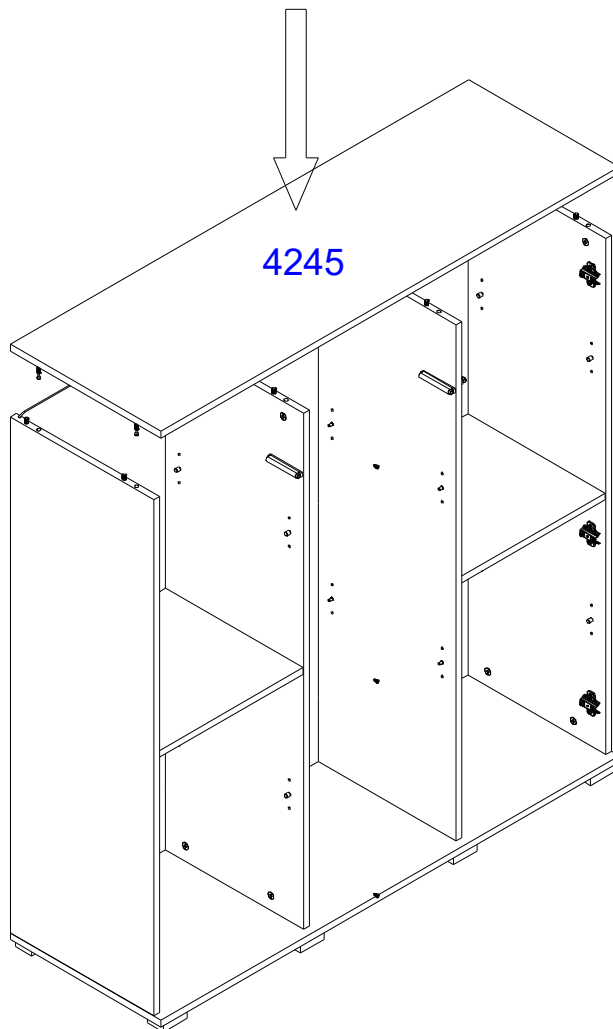
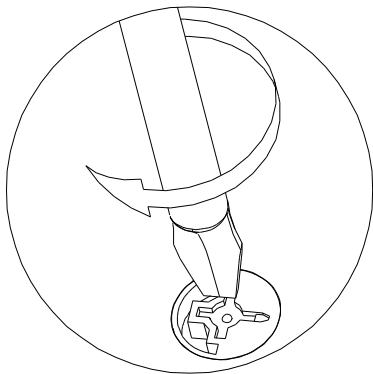

XII

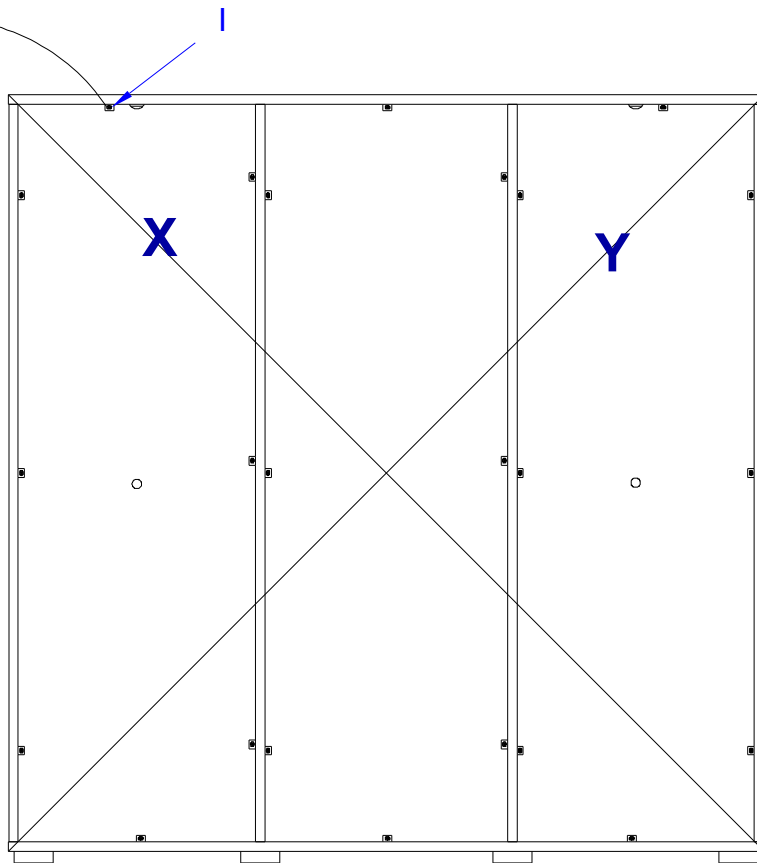
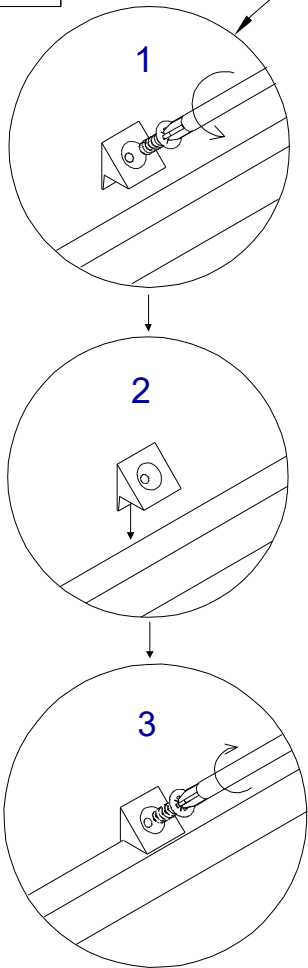

x24

$X=Y$

XIII

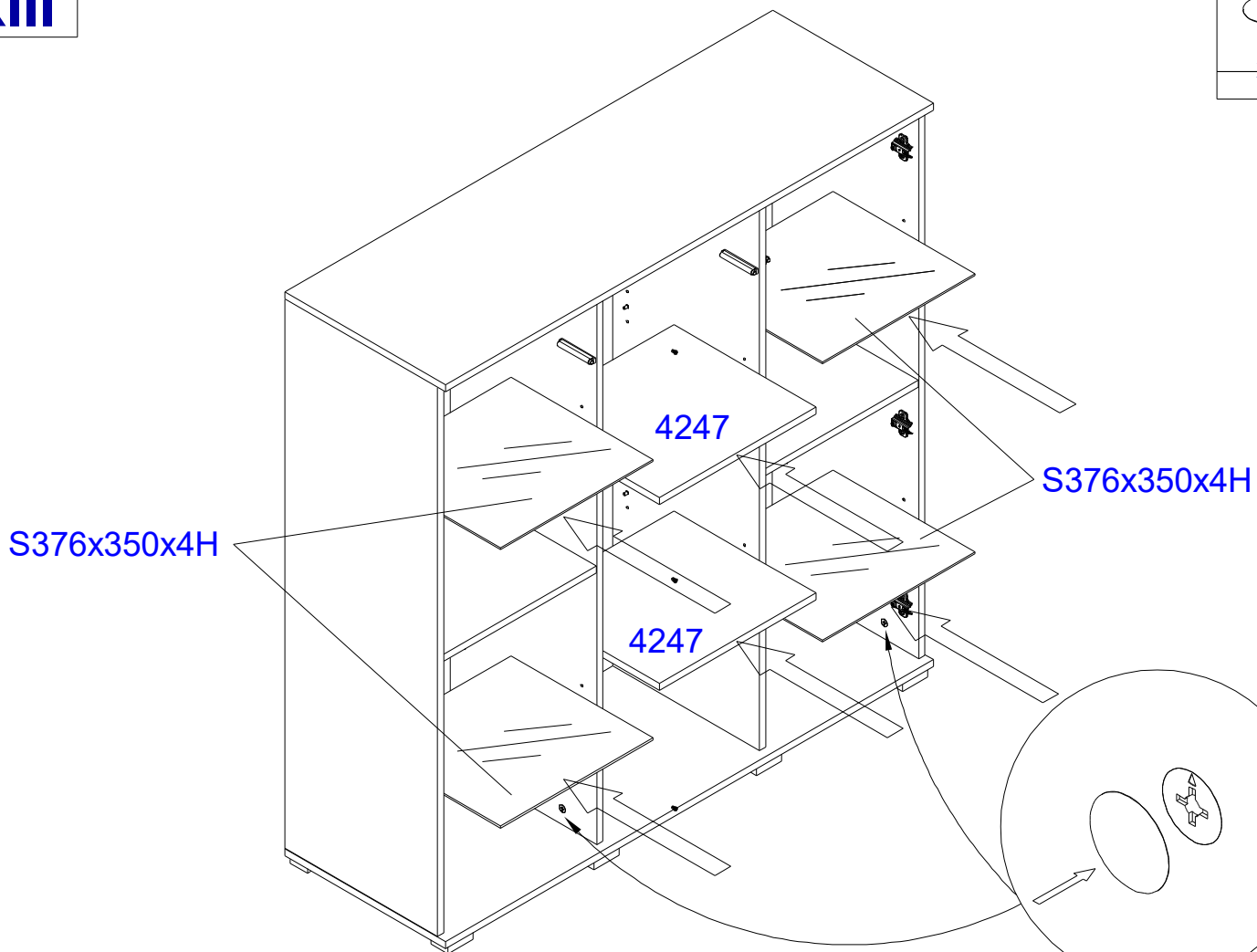

x2 X3
4

XIV

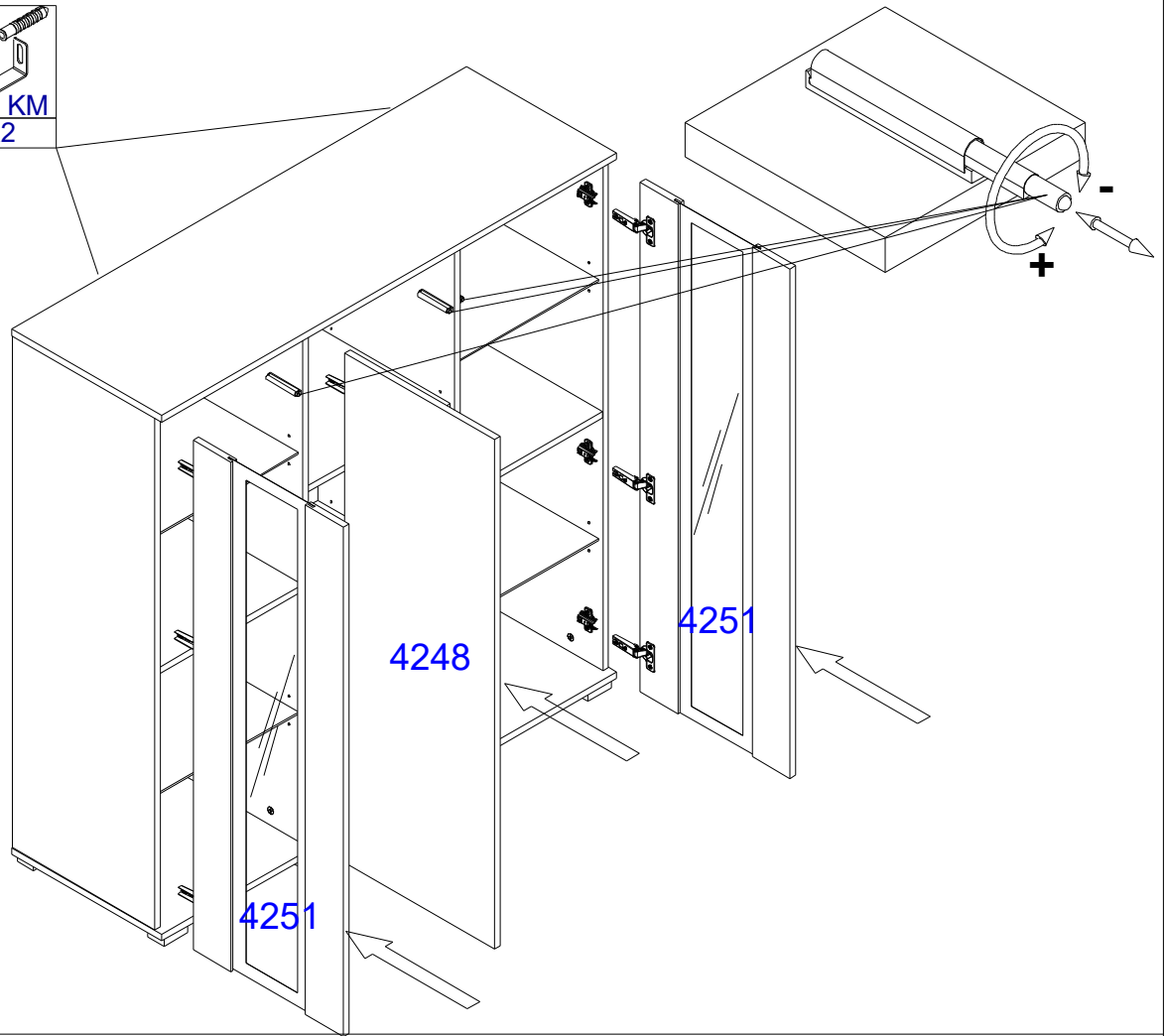
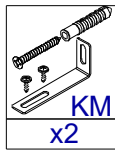

XV

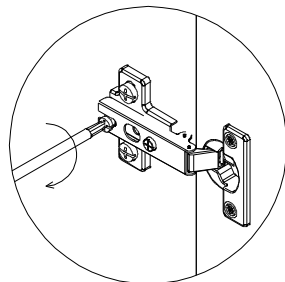
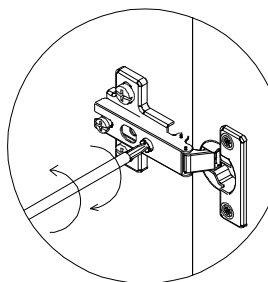
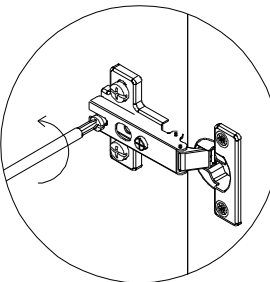
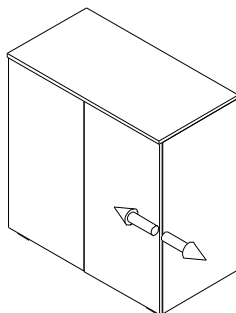
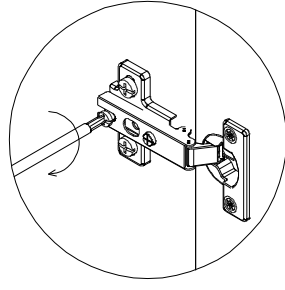
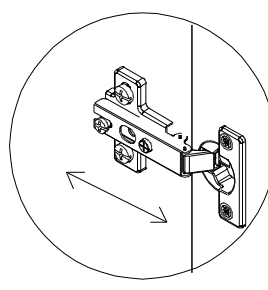
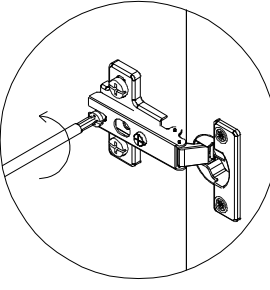
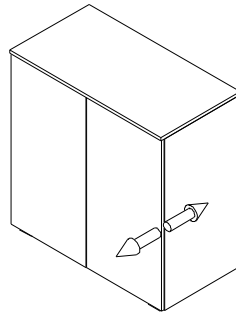
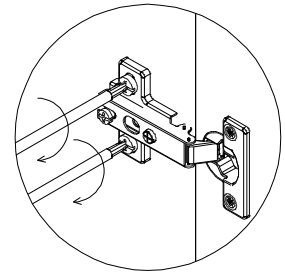
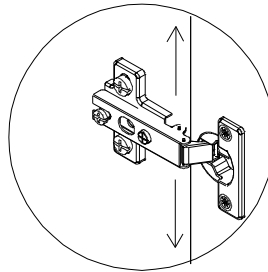
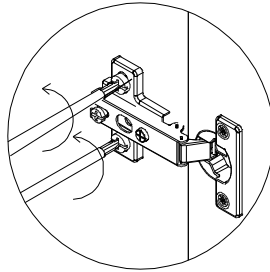
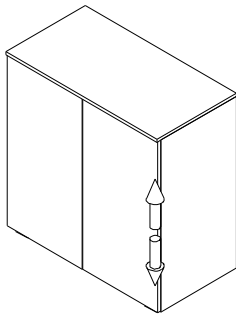

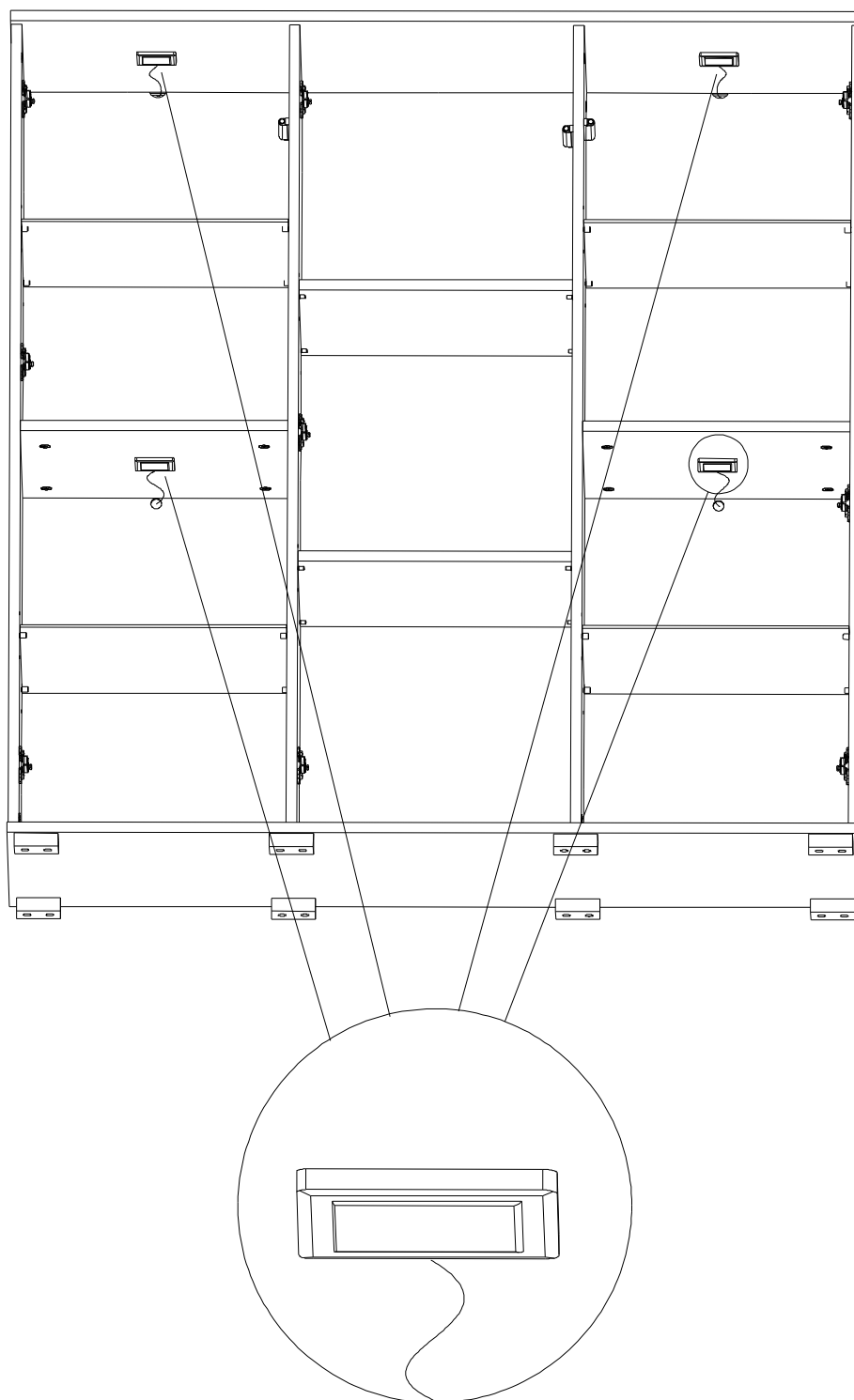

- | | | | |
|----|--|-----|---|
| PL | Uwaga: Punkt mocowania opcjonalnego oświetlenia | RO | Notă: Punct de atașare pentru iluminatul opțional |
| CZ | Poznámka: Připojovací bod pro volitelné osvětlení | SK | Poznámka: Pripojovací bod pre voliteľné osvetlenie |
| D | Hinweis: Befestigungspunkt für optionale Beleuchtung | TR | Not: İsteğe bağlı aydınlatma için bağlantı noktası |
| GB | Note: Attachment point for optional lighting | SE | Obs: Monteringspunkt för valfri belysning |
| F | Remarque: point de fixation pour éclairage optionnel | SLO | Opomba: Montažna točka za dodatno razsvetljavo |
| HU | Megjegyzés: Az opcionális világítás rögzítési pontja | HR | Napomena: Montažna točka za opcijnsko osvjetljenje |
| I | Nota: punto di attacco per illuminazione opzionale | RU | Примечание: точка крепления для дополнительного освещения |
| NL | Opmerking: bevestigingspunt voor optionele verlichting | | |

1

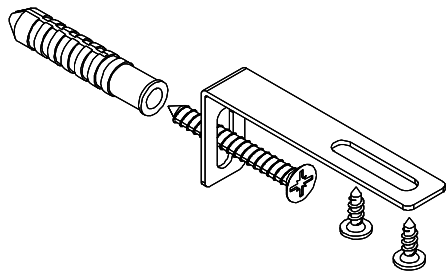

Uwaga . Upozornini. Achtung . Attention . Caution Firyelem . Attenzione . Opgelet . ВНИМАНИЕ . Atentie . Upozornenie . Dikkat . Uppmärksamhet . Uppmärksamhet . Pozor . Pažnja

PL	Mocowanie do ściany jest jednocześnie zabezpieczeniem przed przewróceniem - koniecznie zamontować! Do niektórych rodzajów ścian koniecznie zastosować specjalne kołki mocujące.	I	Il fissaggio alla parete serve da protezione anti-ribaltamento - attaccarla assolutamente! Per alcune strutture di parete può essere necessario un tassello speciale!
CZ	Montáž na stěnu slouží jako ochrana proti převrnutí - bezpodmínečně umístěte! U některých typů stěn může být zapotřebí speciální hmoždinka!	NL	Bevestiging aan de muur dient als kantelbescherming - zeker en vast bevestigen! Bij enkele muurtypes is een speciale plug misschien vereist!
D	Wandbefestigung dient als Kippschutz - unbedingt anbringen! Bei einigen Wandtypen kann ein Spezialdübel erforderlich sein!	RU	Крепление к стене также является защитой от опрокидывания - обязательно установите! Для некоторых типов стен необходимо использовать специальные крепежные штифты.
GB	The wall fastening serves to prevent tipping - be absolutely sure to mount it! For certain wall types, a special wall plug may be necessary!	RO	Sistemul de fixare la perete serve și ca protecție la răsturnare - de montat obligatoriu! Pentru unele tipuri de pereți este posibil să fie necesar un diblu special!
F	La fixation murale sert de protection contre le basculement - à installer impérativement ! Pour certains types de murs il faut des chevilles spéciales !	SK	Upevnenie na stenu slúži ako ochrana proti prevráteniu - bezpodmienečne použite! Pre niektoré druhy stien môže byť potrebná špeciálna hmoždinka!
HU	A termékét a falhoz keletve rögzíteni, különben az felborulhat! Egyes fal típusoknál speciális tiplit kell használni!	TR	Duvardaki sabitleme, devrilmeye karşı, bir emniyet tedbiridir ve mutlaka monte edilmelidir! Bazı duvar tiplerinde bunun için özel bir dübel gereklidir!
SE	Att fästa den på väggen är också ett skydd mot att välta - se till att installera det! För vissa typer av väggar är det nödvändigt att använda speciella monteringsstift.	SLO	Pritrđitev na steno je tudi zaščita pred prevrnitvijo - obvezno jo namestite! Za nekatere vrste sten je treba uporabiti posebne pritrđilne zatiče.
HR	Pričvršćivanje na zid je ujedno i zaštita od prevrtanja - obavezno ga postavite! Za neke vrste zidova potrebno je koristiti posebne pri čvršćne igle.		

2a

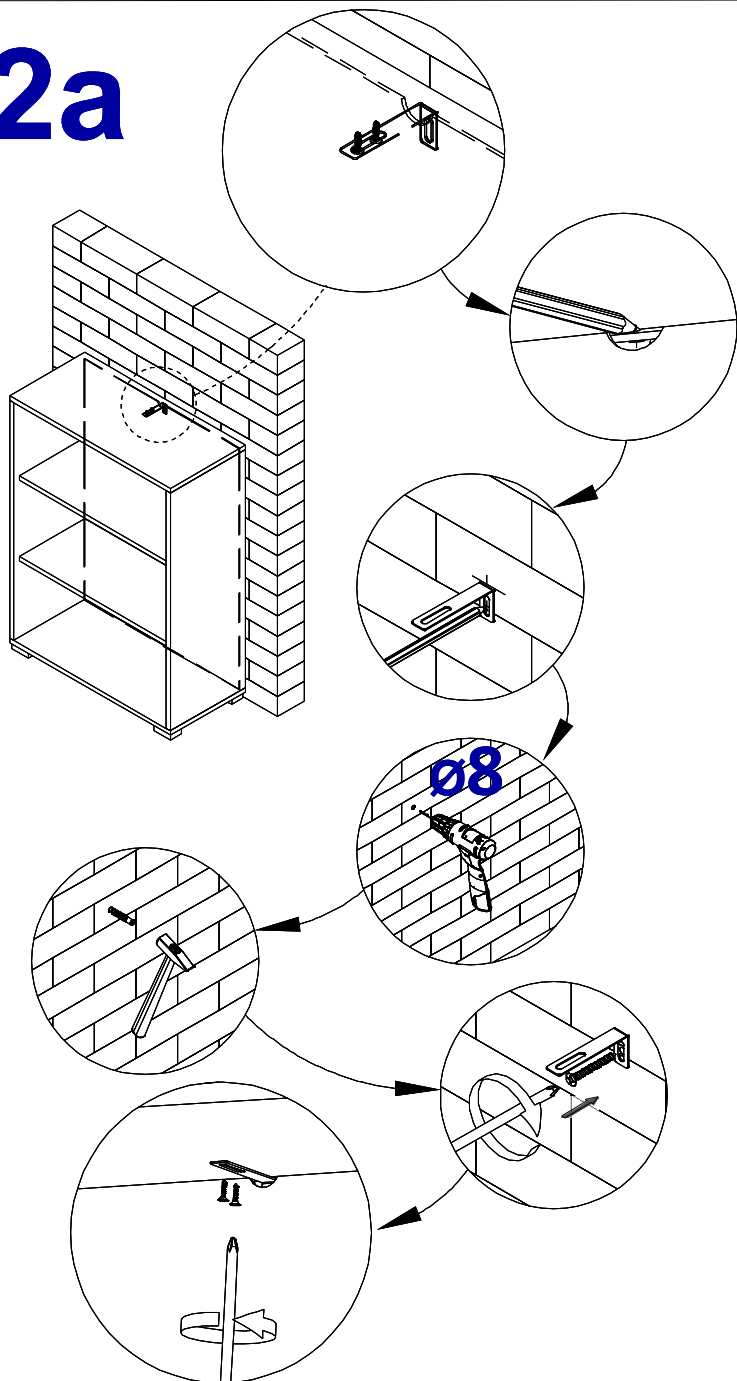

2b

