

# MONTÁŽNÍ/MONTÁŽNY NÁVOD LACO

**PL** Instrukcja montażu

**CZ** Návod k montáži

**D** Montageanleitung

**GB** Assembly instruction

**F** Model d'emploi

**HU** Szerelési útmutató

**I** Istruzione di montaggio

**NL** Handleiding voor de montage

**RU** Инструкция по монтажу

**RO** Instrucțiuni de montare

**SK** Návod k montáži

**TR** Montaj talimatı

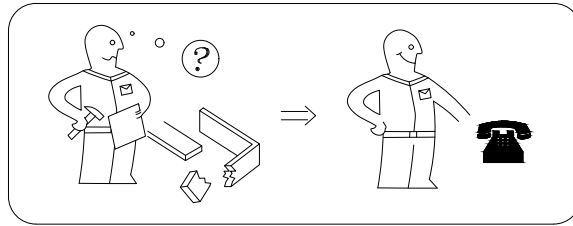
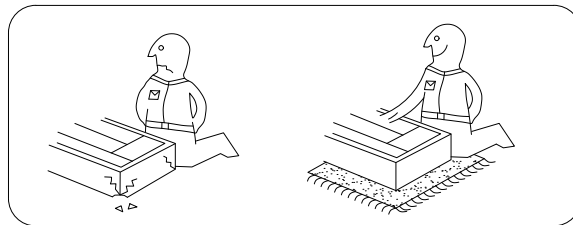
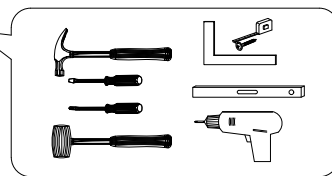
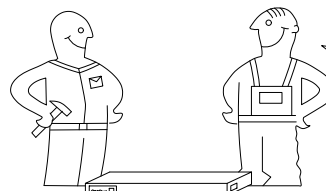

**!** Uwaga • Upozornini • Achtung • Attention • Caution • Figyelem  
**!** Attenzione • Opgelet • Внимание • Atentie • Upozornenie • Dikkat

**PL** Czyszczenie należy wykonać wyłącznie za pomocą ściereczki lub lekko nawilżonego ręcznika. Nie stosować środków czyszczących do szorowania.

**CZ** Čistění je nutné vykonávat výhradně pomoci utěrky nebo lehce navlhčeného ručníku. Nepoužívejte čističí prostředky obsahující abrazivní částice.

**D** Bitte nur mit einem Staubtuch oder leicht feuchtem Lappen reinigen. Keine scheuernden Putzmittel verwenden.

**GB** Please only clean with a duster or a damp cloth. Do not use any abrasive cleaners.

**F** Le nettoyage se fait uniquement à l'aide d'un torchon ou d'une serviette légèrement mouillée.

**HU** A tisztítás kizárólag törölruha vagy enyhén nedvesített törölköző segítségével végezhető. Súroló hatású tisztítószereket nem szabad használni.

**I** Pulire esclusivamente con un panno o un asciugamano umido.

**NL** Reinig alleen met een stofdoek of een lichtjes vochtige doek. Gebruik geen schurende poetsmiddelen.

**RU** Очищайте от пыли тряпкой или слегка влажной ветошью. Не допускается применение чистящих средств, не предназначенных для ухода за мебелью.

**RO** Curățarea trebuie efectuată numai cu o cârpă sau cu un prosop ușor umezit. Nu utilizați agenți de curățare abrazivi.

**SK** Čistenie je nutné vykonávať výhradne pomoci utierky alebo ľahko zvlhnutým ručníkom. Nepoužívajte čistiace prostriedky obsahujúce abrazívni častice.

**TR** Lütfen sadece bir toz bezilye veya hafif nemli yumuşak bir bezle siliniz. Aşındırıcı temizlik malzemeleri kullanmayınız.

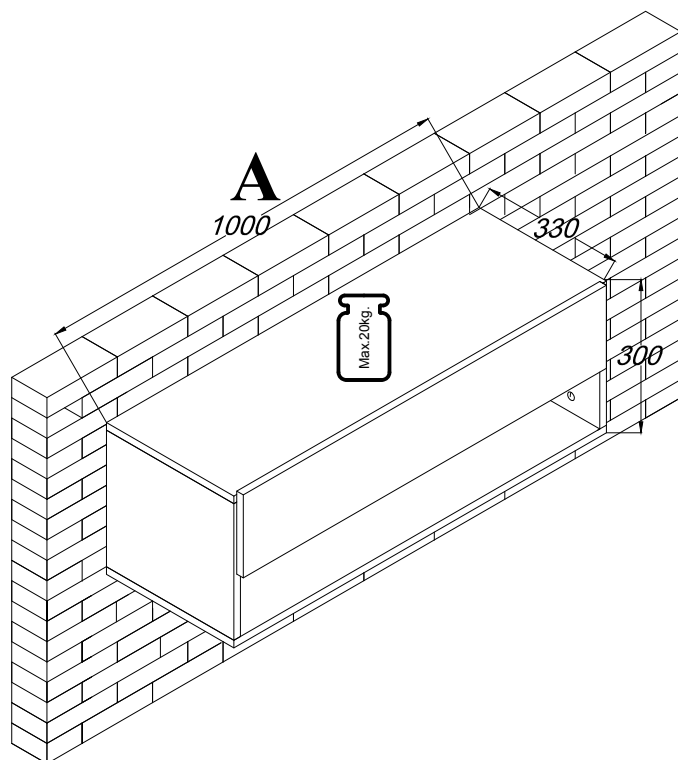



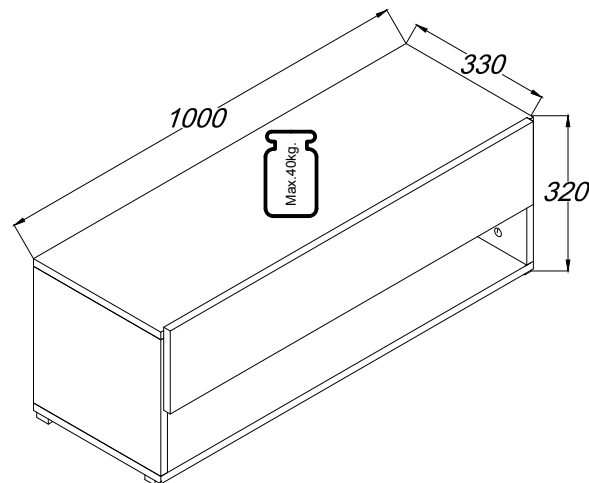

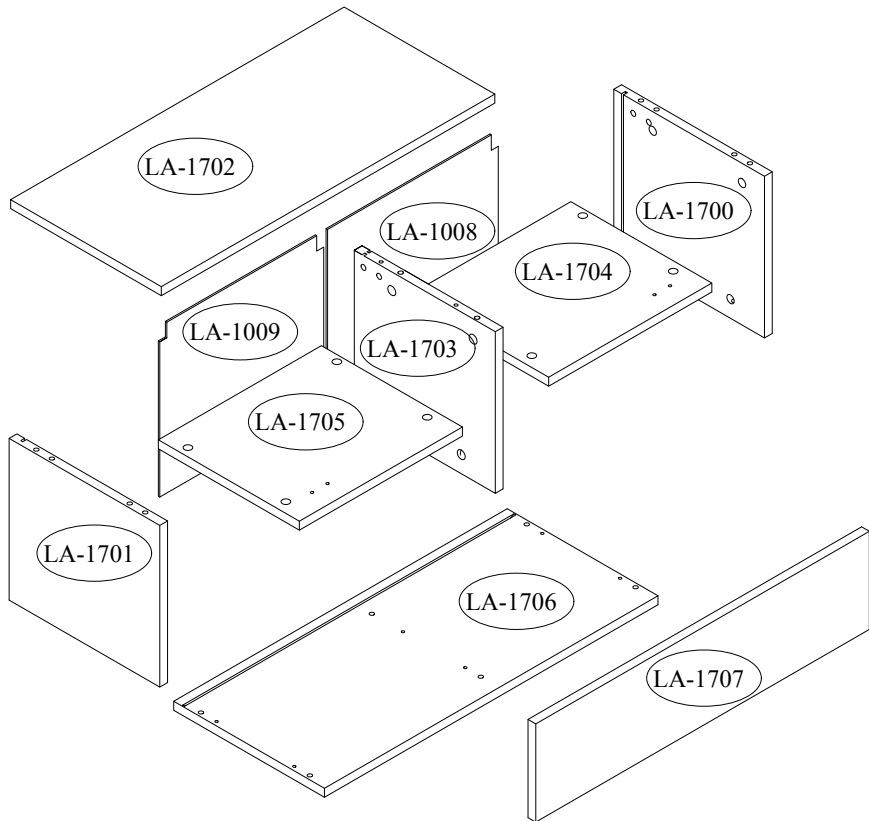
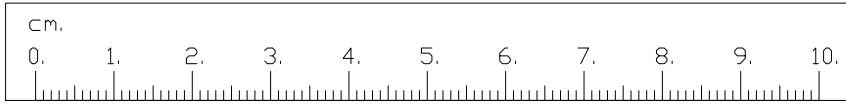
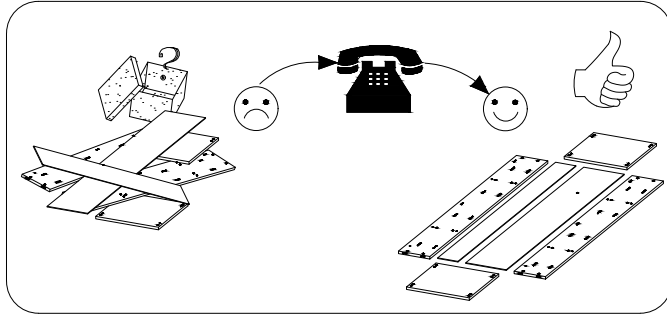
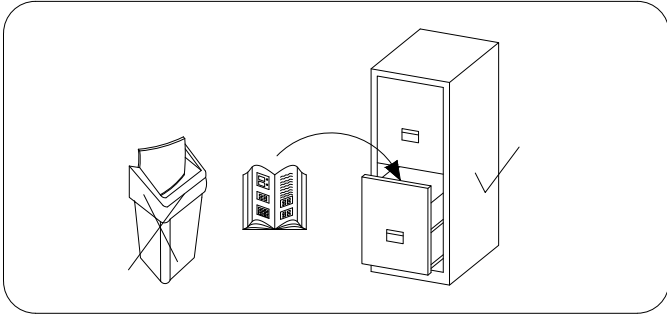

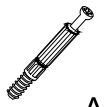

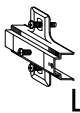
**B**

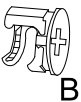





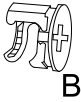
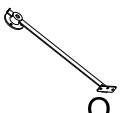







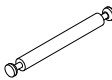

A
12

	8.0x30 	
L	D	B
2	8	8

	4.0x30 	8.0x30 			3.0x13 	
G	H1	D	B	Q	H	A
2	4	8	8	2	6	4

	4.0x30 	8.0x30 	
G	H1	D	B
1	2	4	4

# V-VIII-IX-X-XIII

	6.3X13 			3.0x13 			4.0x25 
A1	F	Z	X	H	I	M	G1
2	4	2	20	6	8	6	12

Ø-10.0 
KR
1



**Uwaga • Upozornini • Achtung • Attention • Caution • Figyelem  
Attenzione • Opgelet • Внимание • Atentie • Upozornenie • Dikkat**



<b>PL</b>	<p>Załączony zestaw montażowy do zamocowania artykułu do ściany (kołki, wkręty, haki itp.) , przeznaczony jest wyłącznie do montażu artykułu na ścianach wykonanych z cegły lub betonu. Przy montażu artykułu na ścianie wykonanej z innych materiałów, należy zastosować odpowiednie do niej zamocowania. W razie wątpliwości prosimy zasięgnąć porady fachowca.</p> <p>Uwaga: Mocowanie mebla do ściany mogą przeprowadzić wyłącznie wykwalifikowane osoby, z uwagi na zastosowanie odpowiednio dopasowanych kołków do rodzaju ściany.</p>
<b>CZ</b>	<p>Přiložený materiál pro montáž na stěnu ( hmoždinky a šrouby) je vhodný jen pro pevné zdivo ( např. betonové nebo cihlové stěny) . Pro jiné skladby stěn budou případně nutné speciální hmoždinky a jiné šrouby. Poradte se případně s odborníkem.</p> <p>Pozor: Montáž nábytku na stěnu musí provést odborník, protože k montáži na stěnu jsou zapotřebí upravené hmoždinky.</p>
<b>D</b>	<p>Das beigefügte Wandbefestigungsmaterial ( Dübel und Schrauben) eignet sich nur für festes Mauerwerk ( z.B. Beton- oder Ziegelwände) . Für andere Wandaufbauten sind eventuell Spezialdübel und andere Schrauben notwendig. Ziehen Sie gegebenenfalls eine Fachkraft zurate.</p> <p><b>Achtung:</b> Die Befestigung des Möbelstückes an der Wand muss von einer fachkundigen Person vorgenommen werden, da für die Montage an die Wand angepasste Dübel erforderlich sind.</p>
<b>GB</b>	<p>The enclosed wall mounting materials ( dowels and screws) are only suitable for solid masonry ( e. g. concrete or brick walls) . Special dowels and other screws may be necessary for other wall constructions. If necessary, please consult a qualified professional.</p> <p><b>Attention:</b> A qualified professional is required when mounting furniture to the wall since dowels corresponding to the wall are required for this.</p>
<b>F</b>	<p>Le matériel de fixation murale fourni ( chevilles et vis) convient uniquement à des murs solides ( p. ex. murs en béton ou en briques) . Pour les autres constructions de murs, il faut éventuellement des chevilles spéciales et d'autres vis. Faites-vous conseiller par un spécialiste.</p> <p><b>Attention :</b> La fixation du meuble contre le mur doit être effectuée par une personne compétente car, pour le montage mural, il faut utiliser des chevilles adaptées.</p>
<b>HU</b>	<p>A mellékelt fali rögzítőkészlet ( tipli és csavarok) csak tömött falazatban ( pl. betonfalban, téglafalban) használható. Más faltípusokhoz speciális tiplire és csavarra lesz szükség. Szükség esetén kérje ki egy szakember véleményét</p> <p><b>Figyelem:</b> A bútorelemek falra rögzítését szakembernek kell végeznie, mert a rögzítéshez megfelelő tiplit kell használni.</p>
<b>I</b>	<p>I materiali di fissaggio allegati ( tasselli e viti) sono adatti solo ai muri compatti ( ad es. di calcestruzzo o mattoni) . Per altri tipi di pareti è probabile che occorrono tasselli speciali e altre tipologie di viti. Richiedere eventualmente il consiglio di un esperto.</p> <p><b>Attenzione:</b> Il fissaggio del mobile alla parete deve essere eseguito da persone esperte, dato che occorrono tasselli adeguati</p>
<b>NL</b>	<p>Het bijgeleverde bevestigingsmateriaal ( pluggen en schroeven) is geschikt voor vaste muren ( bijv. betonnen of bakstenen muren) . Voor andere muurconstructies zijn eventueel speciale pluggen en andere schroeven noodzakelijk. Consulteer eventueel een vakman</p> <p><b>Opgelet:</b> een vakkundige persoon dient het meubelstuk aan de muur te bevestigen; voor de montage aan de muur zijn immers aangepaste pluggen vereist.</p>
<b>RU</b>	<p>Входящий в комплект поставки материал для крепления на стене (дюбели и болты) предназначен только для прочных каменных стен (например, бетонных или кирпичных). Для других типов стен используйте по мере необходимости специальные дюбели и другие болты. По мере необходимости обратитесь за помощью к специалистам.</p> <p><b>Внимание:</b> Поскольку для монтажа на стене необходимо использовать специальные дюбели, мебель должна быть закреплена на стене квалифицированным персоналом.</p>
<b>RO</b>	<p>Materialul furnizat pentru montajul de perete ( dibluri și șuruburi) este adecvat numai pentru zidărie solidă ( de exemplu pereți din beton sau din cărămidă) . Pentru alte structuri de pereți, este posibil să fie necesare dibluri speciale, precum și alte șuruburi. Dacă este necesar, consultați un specialist.</p> <p><b>Atenție:</b> Fixarea la perete a piesei de mobilier se realizează numai de către personal competent, deoarece montajul de perete necesită dibluri adecvate.</p>
<b>SK</b>	<p>Priložený materiál pre upevnenie na stenu ( hmoždinky a skrutky) je vhodný len pre pevné murivo ( napr. betónové alebo tehlové steny) . Pre iné steny sú potrebné príp. špeciálne hmoždinky a iné skrutky. V prípade potreby sa poradte s odborníkom.</p> <p><b>Pozor:</b> Upevnenie nábytku na stenu musí vykonať odborník, nakoľko sú pre montáž na stenu potrebné vhodné hmoždinky.</p>
<b>TR</b>	<p>Teslimat kapsamındaki duvar tipi sabitleme materyali (dübel ve vidalar) sadece beton ve tuğla duvarları gibi sağlam duvar yapıları için uygundur. Başka duvar yapıları için özel dübeller veya başka vidalar gerekli olabilir. Gerekirse bir uzmandan yardım alınız.</p> <p><b>Dikkat:</b> Mobilya parçasının duvara sabitlenmesi, duvar montajı için özel uyarlanmış dübeller gerektirdiğinden bu iş sadece bu konuda uzman bir kişi tarafından gerçekleştirilmelidir.</p>

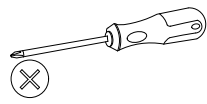

1x

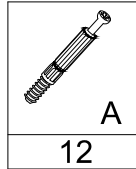

1x

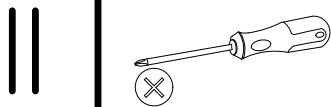
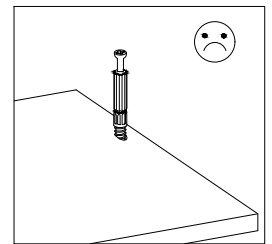
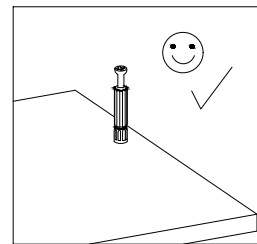
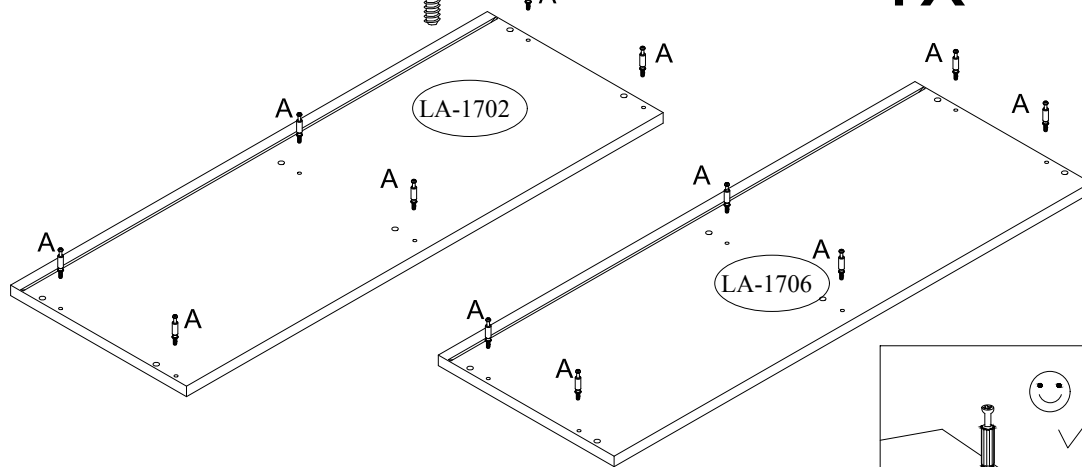

1x



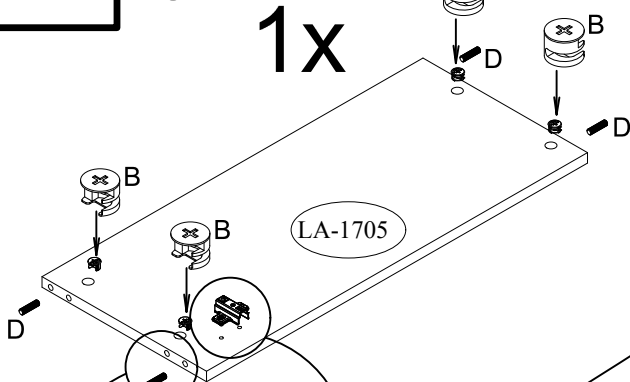

	8.0x30 	
2	8	8

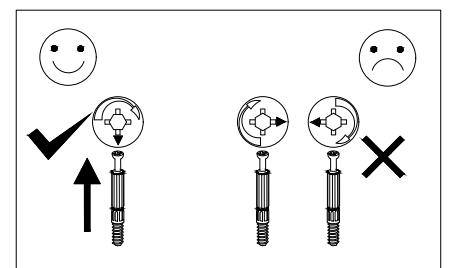
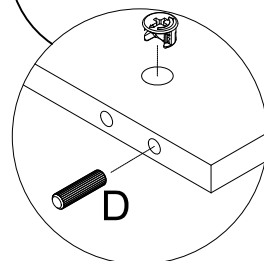
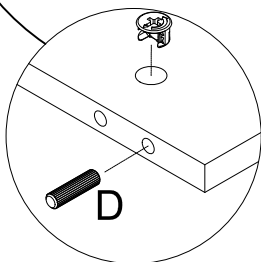
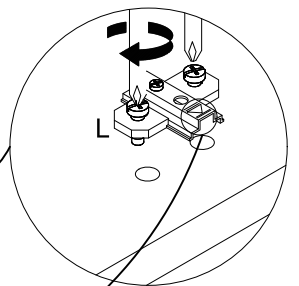
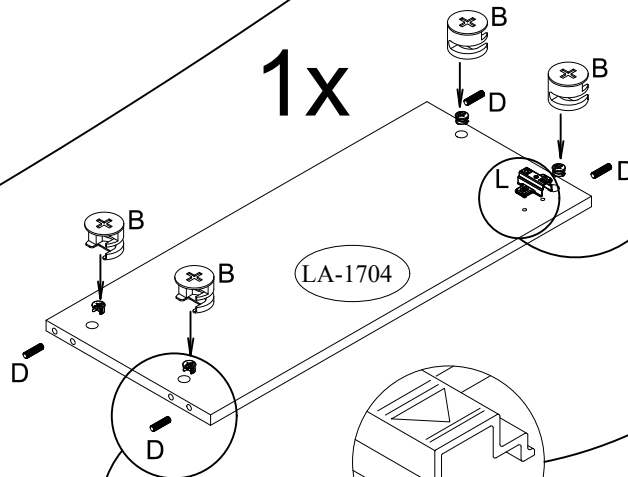
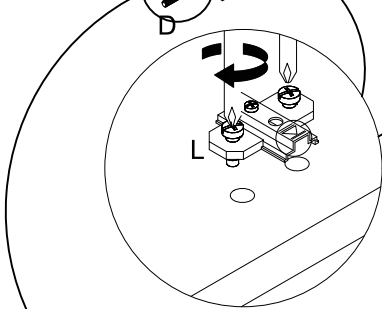

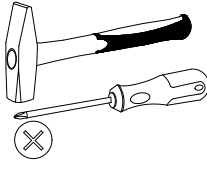
1x

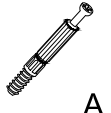

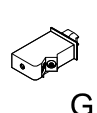
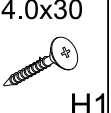

	3.0x13 		4.0x30 	8.0x30 	
A	H	G	H1	D	B
4	6	2	4	8	8

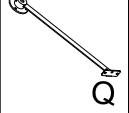

Q
2

1x

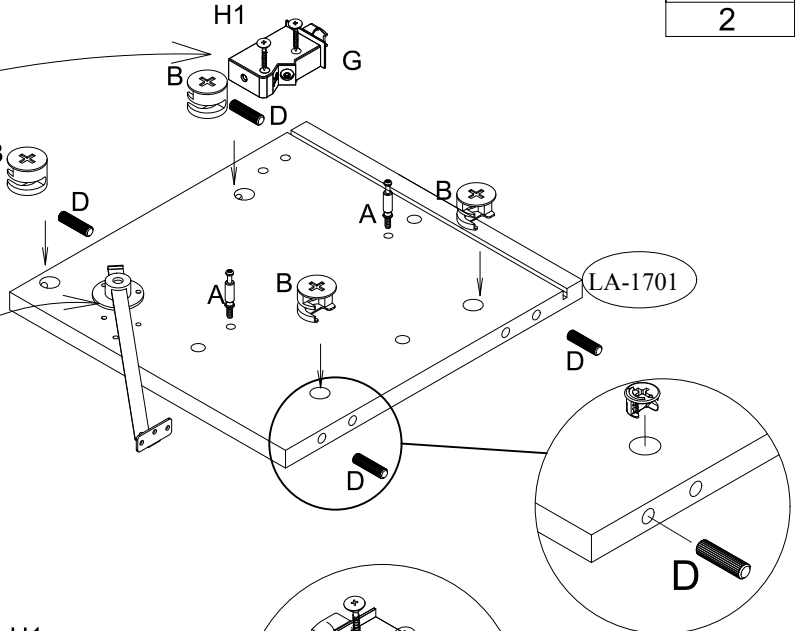
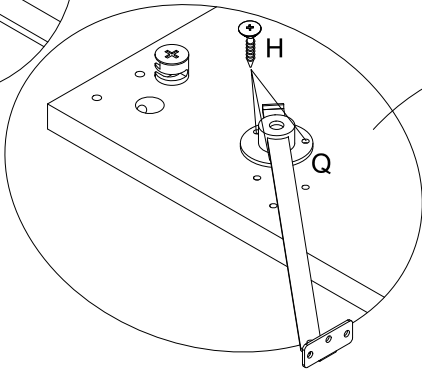
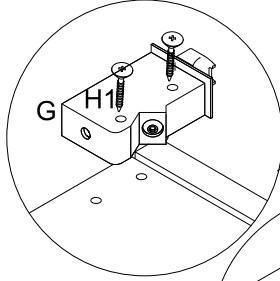

1x

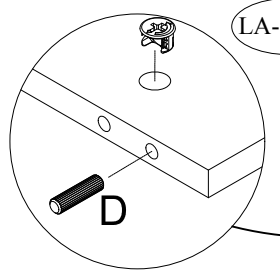

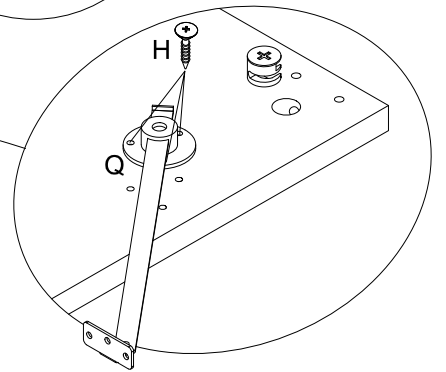
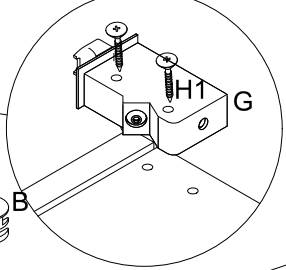
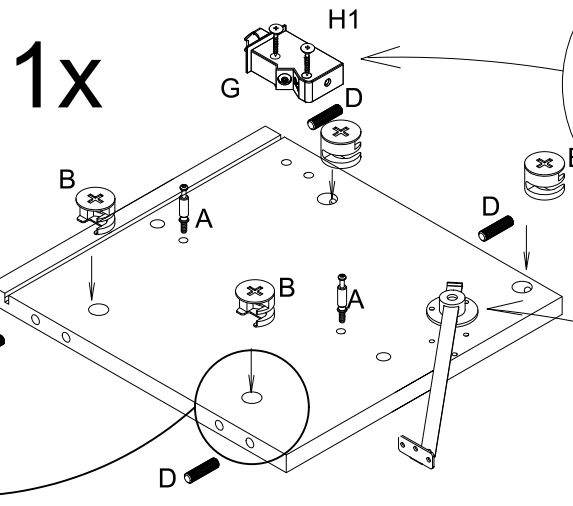

LA-1700

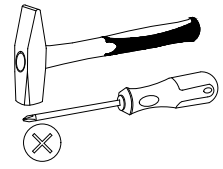

IV

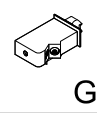

1x

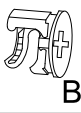
	4.0x30 	8.0x30 	
G	H1	D	B
1	2	4	4

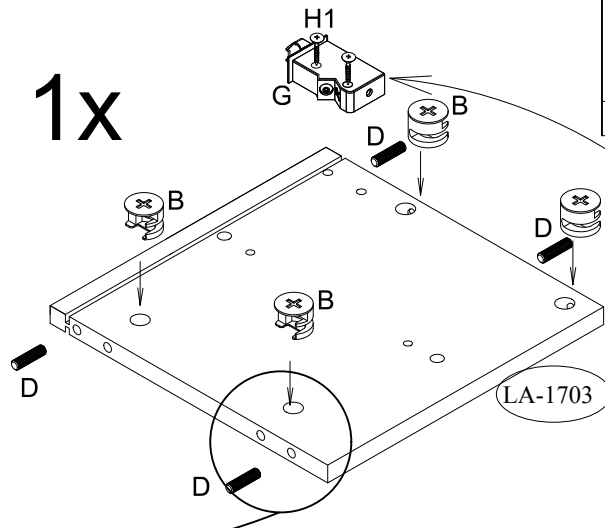
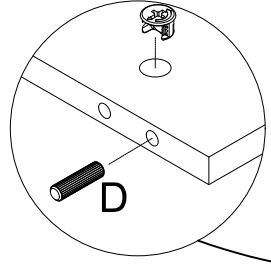

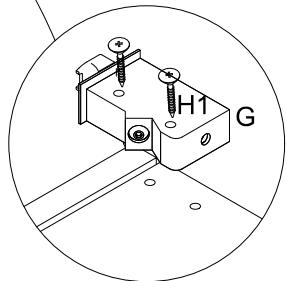

LA-1703

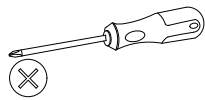

V

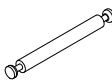

	6.3X13 	
A1	F	Z
2	4	2

1x

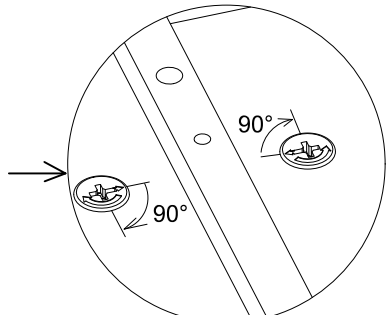
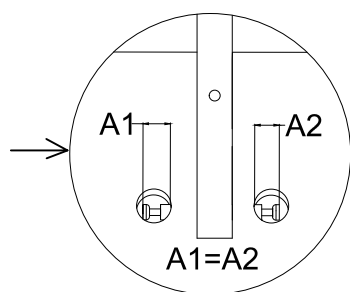
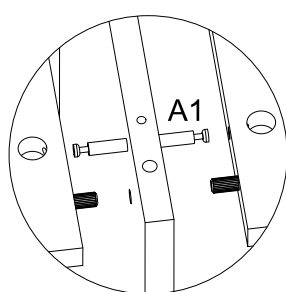
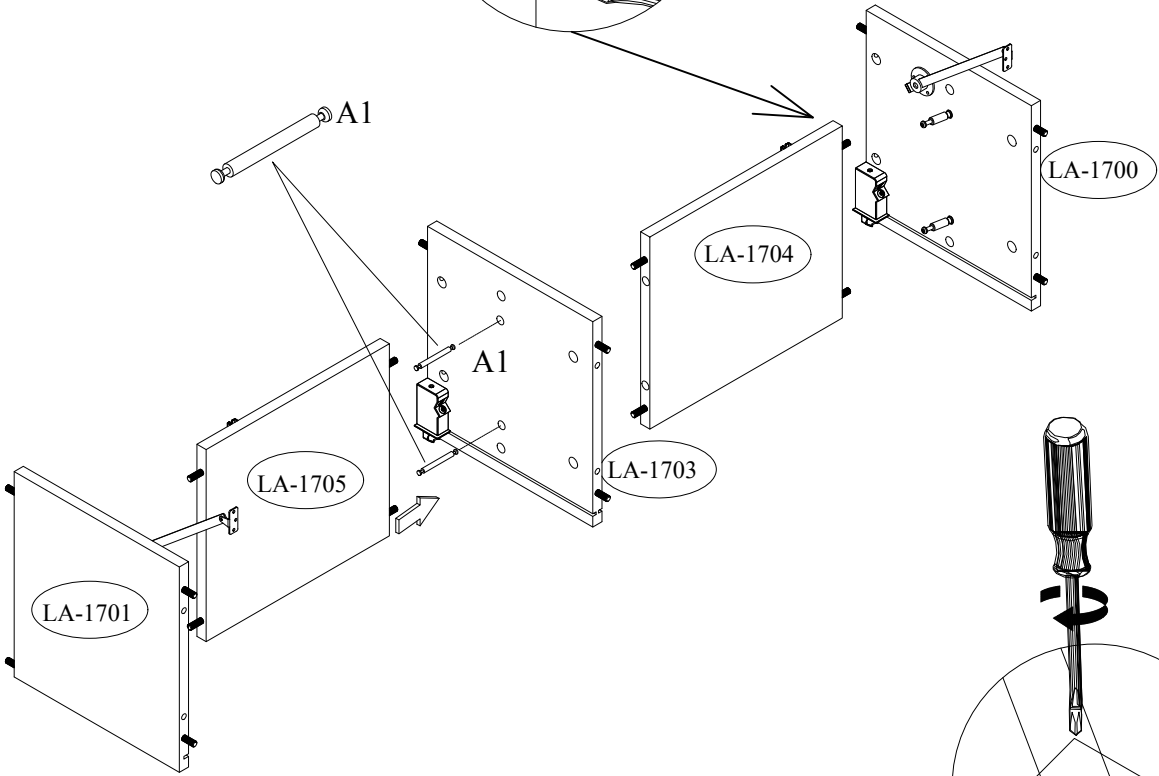
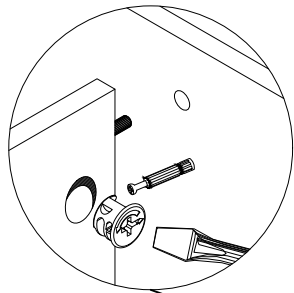
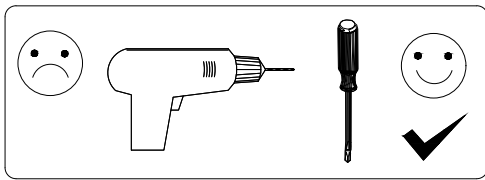
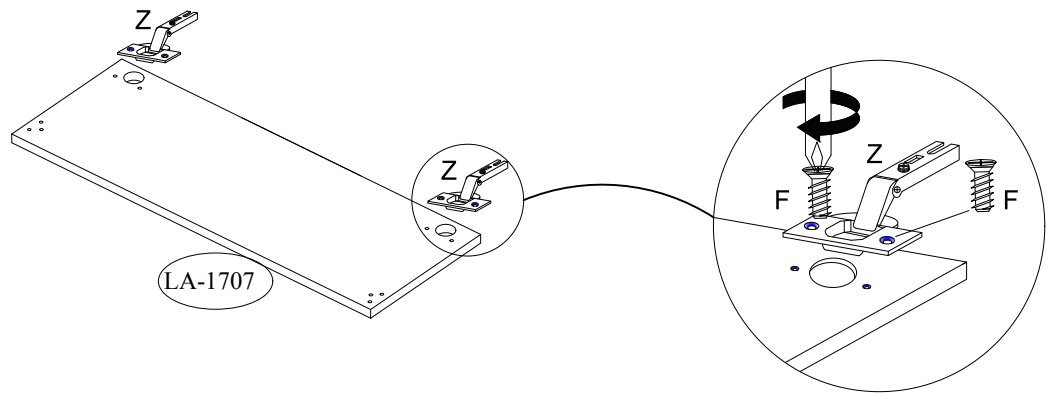

# VI

MAX.100 mm

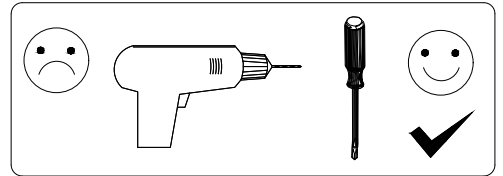
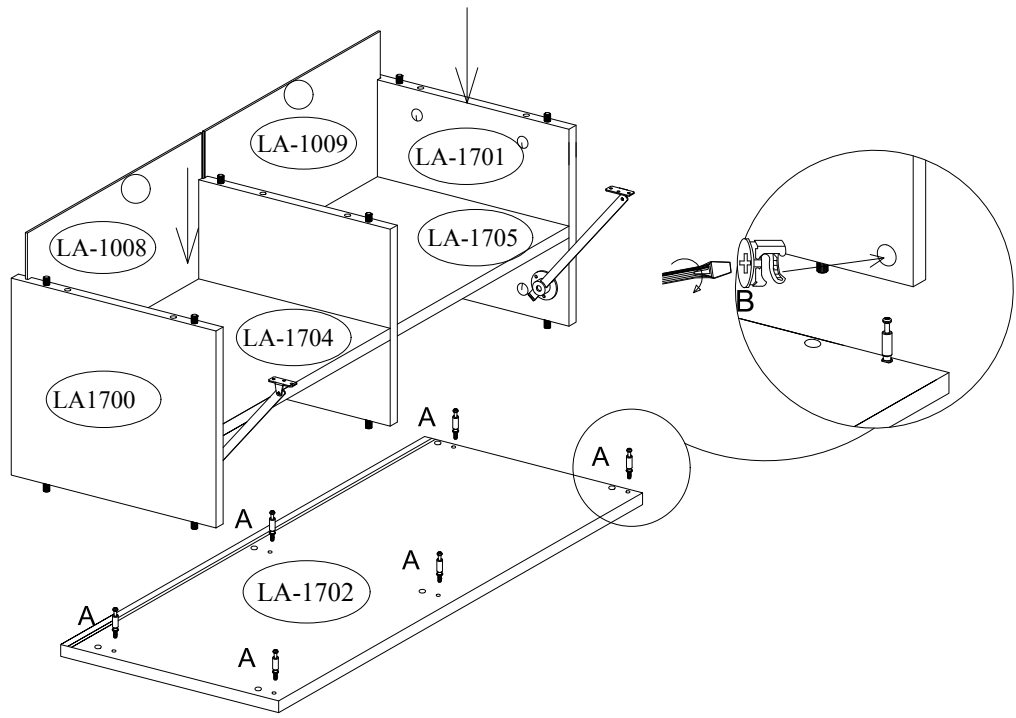

# VII

MAX.100 mm

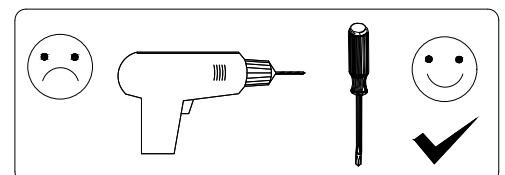
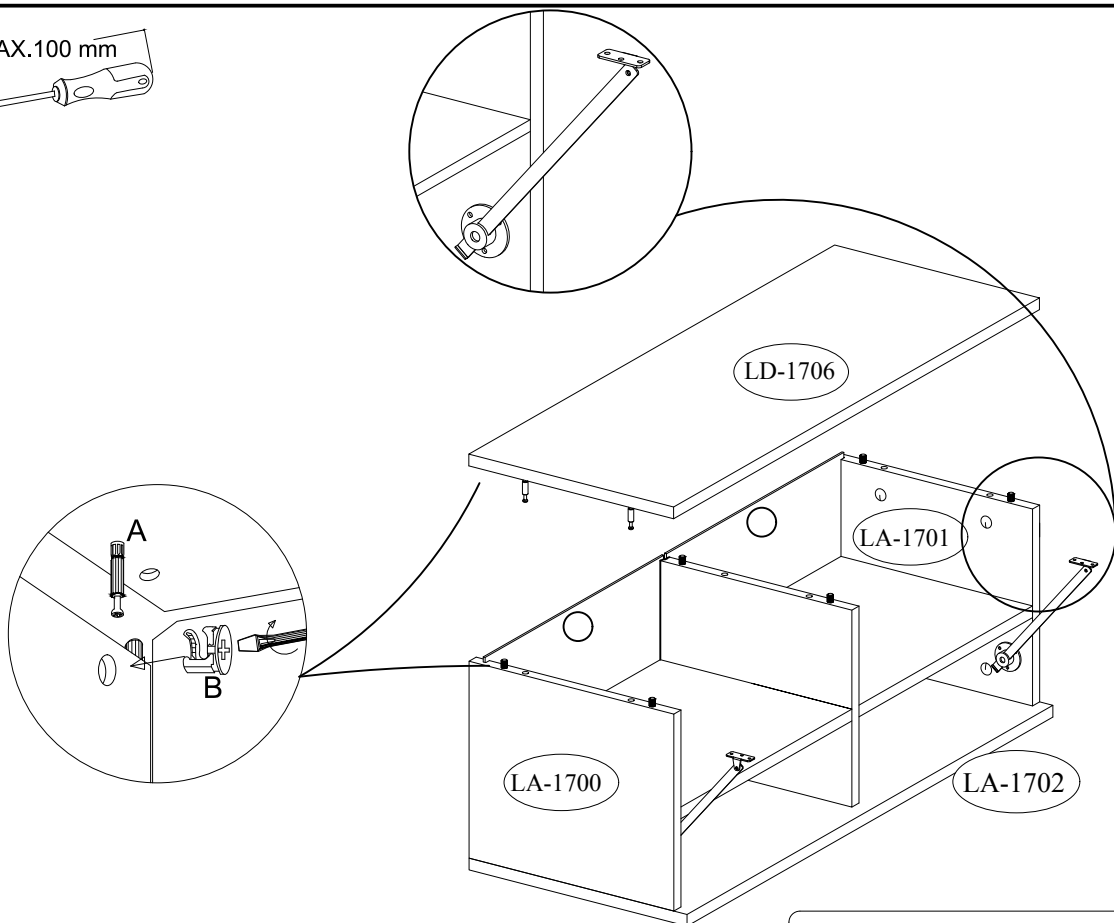

# VIII

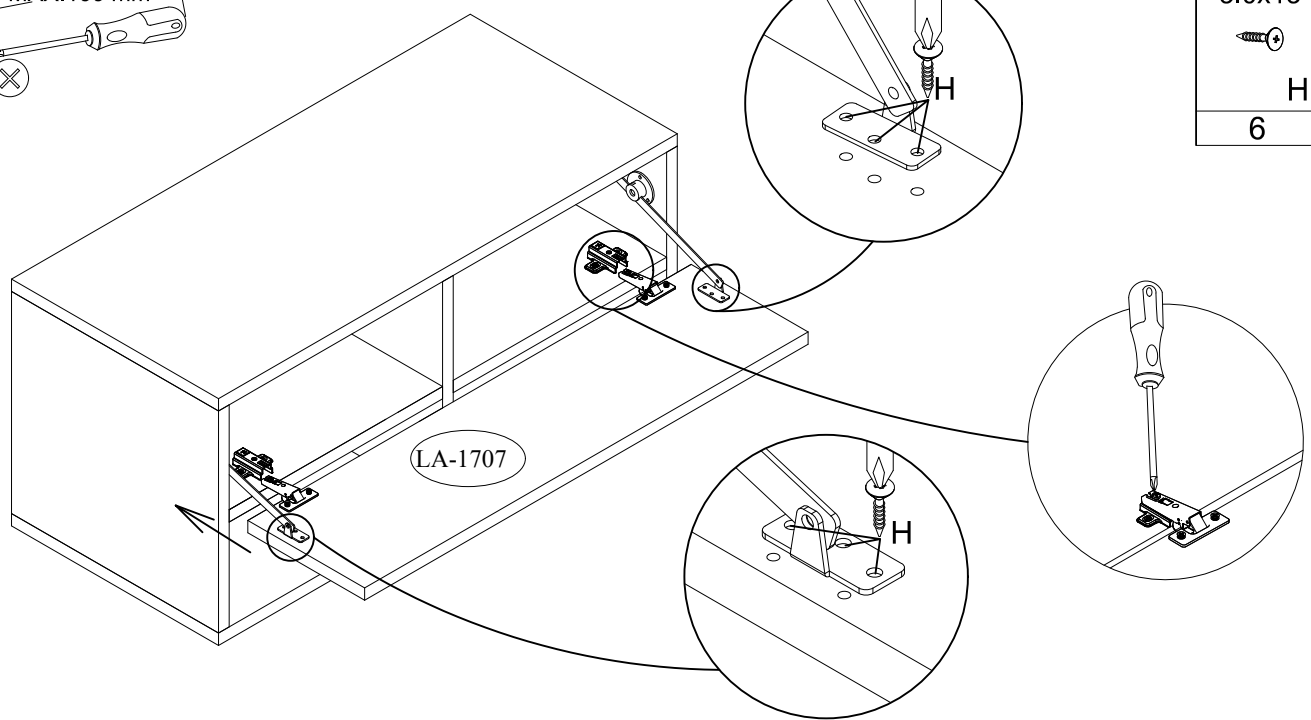
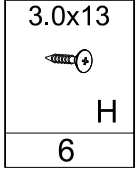
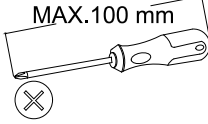

# IX

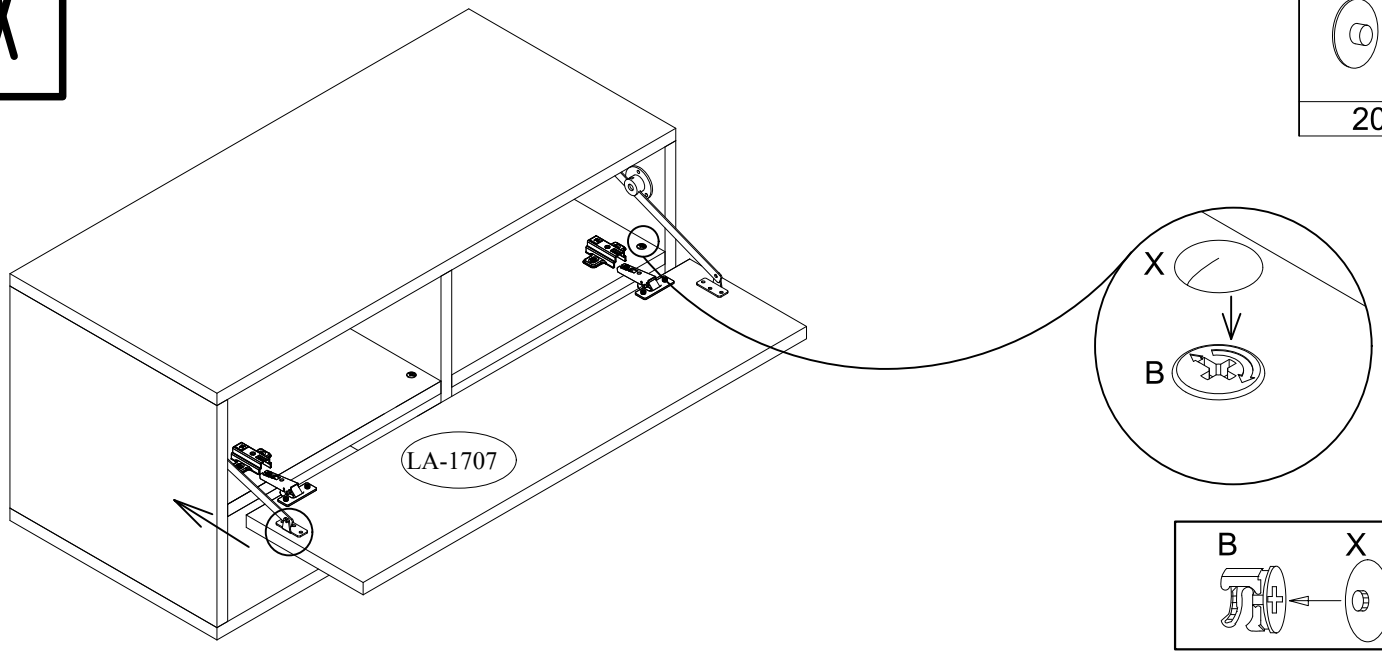
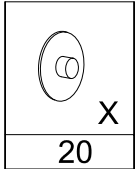

# X

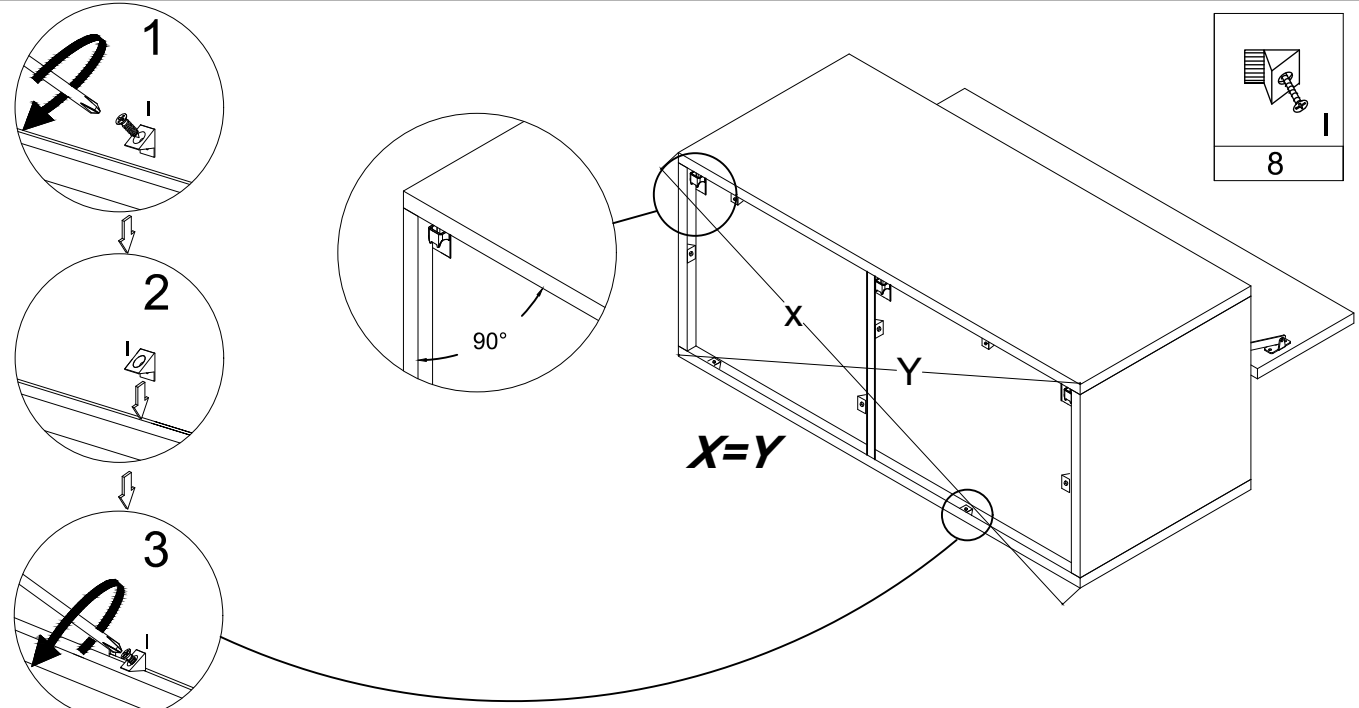
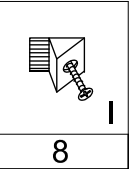

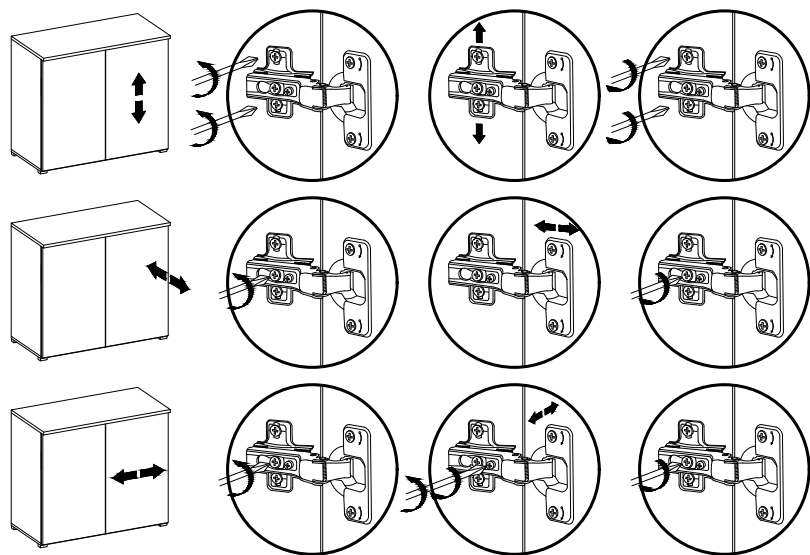

- (F) Mettre la porte (égaliser les gonds)
- (I) Regolare la porta (livellare le parentesi)
- (D) Turen einstellen (Scharniere justieren)
- (GB) Adjusting the doors (adjusting the hinges)
- (NL) Deuren instellen (scharnieren afstellen)
- (PL) Nastawic drzwi (wyrownac zawiasy)
- (TR) Kapilarin ayarlanmasi (menteşelerin seviye ayari)
- (RU) Регулировка дверей (регулировка шарнира)
- (RO) Ajustați ușa (aliniați balamalele)
- (CZ) Seřid'te dveře (vyrovnejte závěsy)
- (SK) Zrad'te dvere (vyrovnajzte závesy)
- (HU) Állítsa be az ajtót (igazítsa be a zsanérokot)

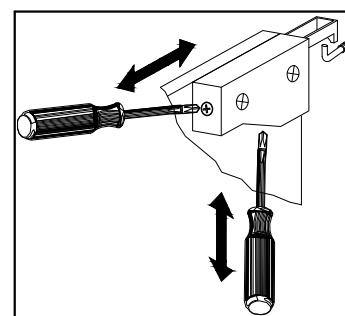
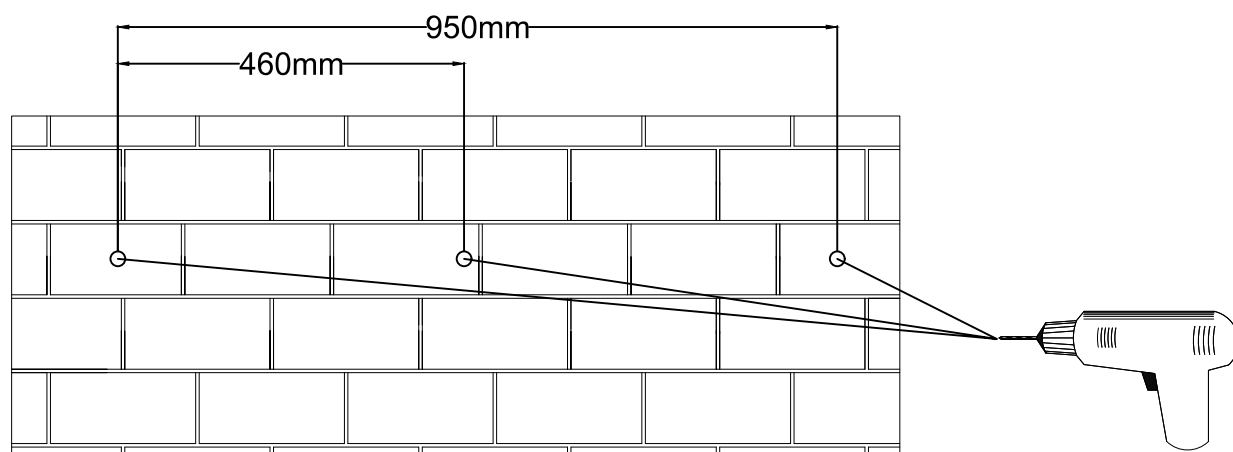

- (PL)** Uwaga: Punkty mocowania opcjonalnego oświetlenia
- (CZ)** Upozornění: body k připevnění doplňkového osvětlení
- (D)** Hinweis: Befestigungspunkte für optionale Beleuchtung
- (GB)** N.B.: Fixing points for optional lighting
- (F)** Remarque: Points de fixation de l'éclairage optionnel
- (HU)** Figyelem: Opcionális világítás rögzítési pontjai
- (I)** NOTA: punti di fissaggio opzionale dell'illuminazione
- (NL)** OPGELET: Optionele bevestigingspunten van de verlichting.
- (RU)** ВНИМАНИЕ: Точки крепления дополнительного освещения
- (RO)** Atenție: Punctele opționale de fixare a iluminatului
- (SK)** Upozornenie: body k pripevnení dodatočného osvetlení
- (TR)** Dikkat: Seçenekli aydınlatmanın yerleştirilmesinin noktaları

OSWLED2PBZ-SQUSIE

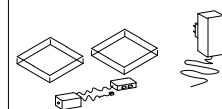

1 kpl.

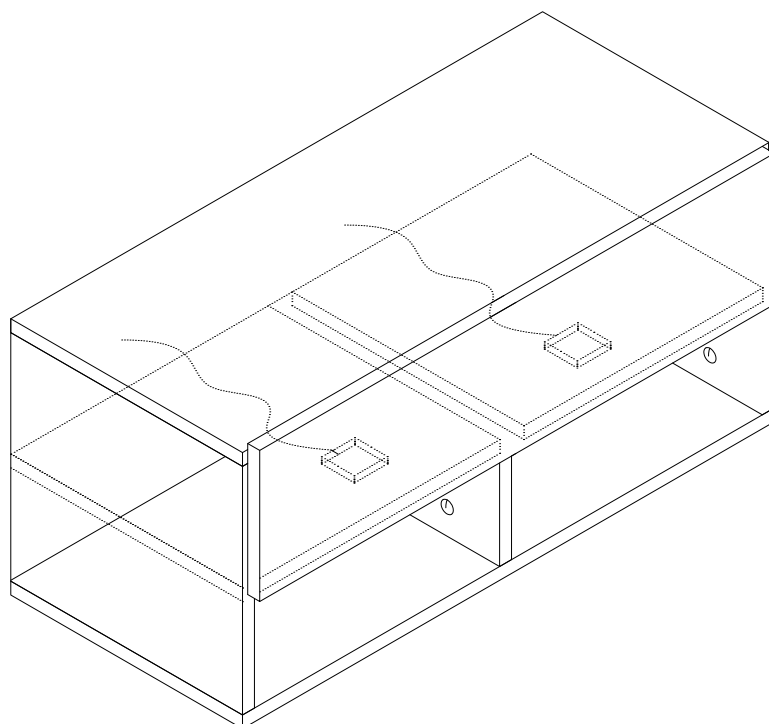

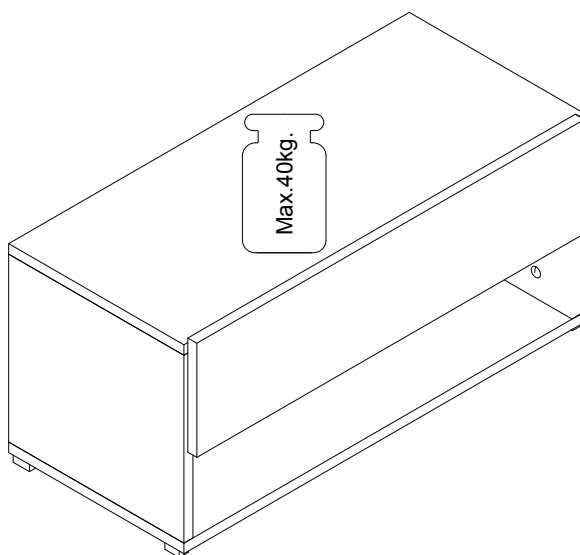

XII

B

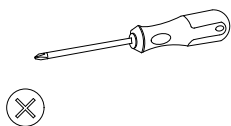

XIII



	4.0x25
M	
4	G1 8

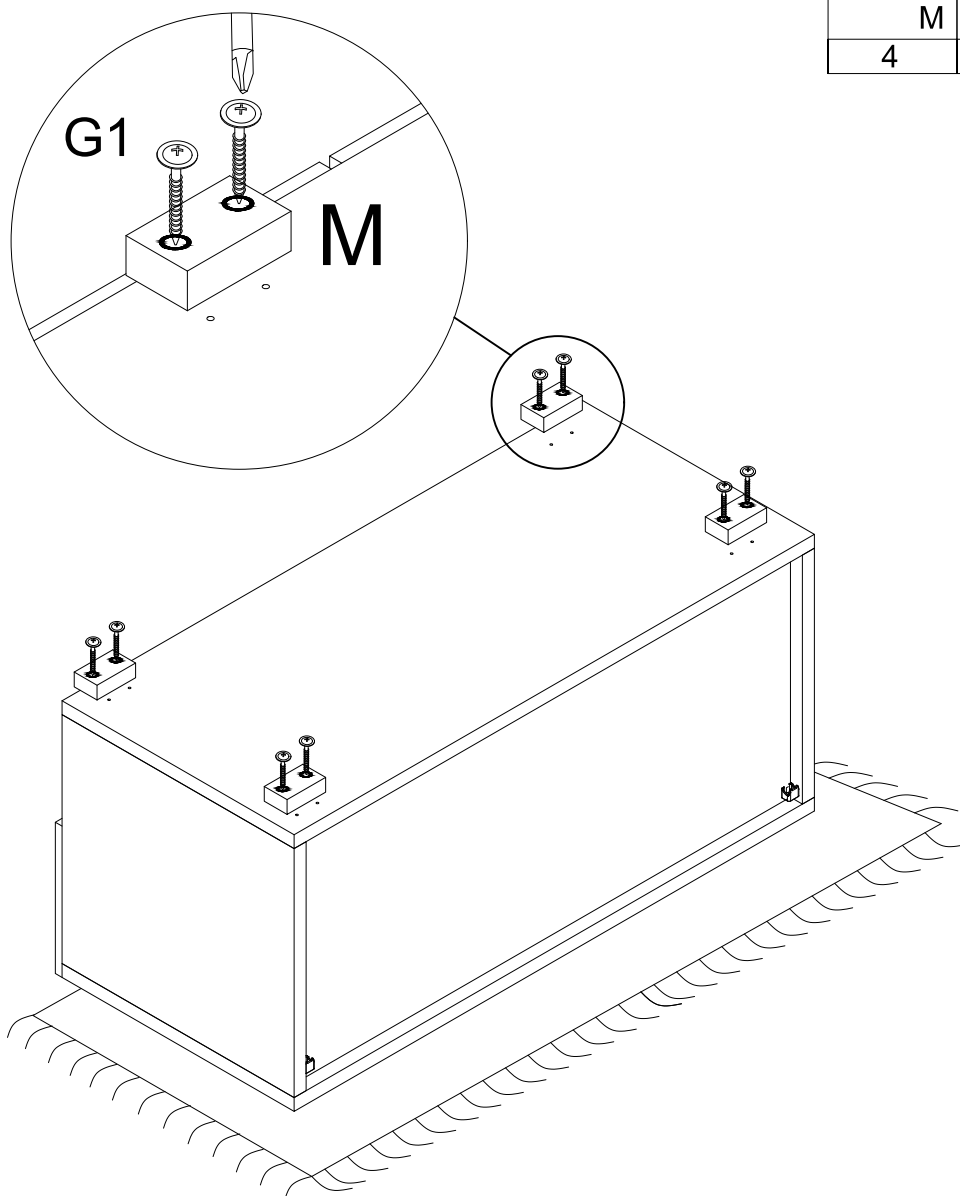

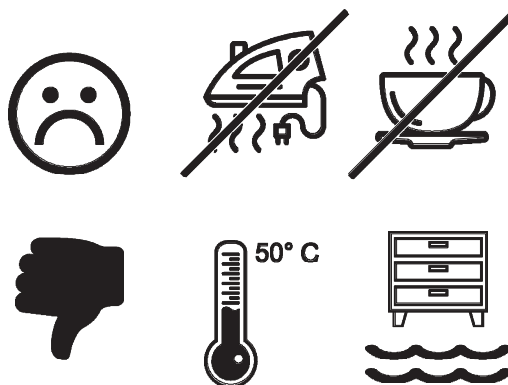
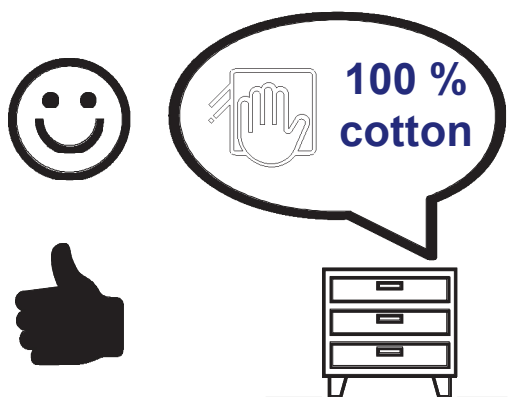

FR

Donnez ou recyclez vos meubles.



Association

ou



Magasin

ou



Déchèterie



CARTON  
+ PLASTIQUE  
+ NOTICE



Séparez les éléments avant de trier