

MODEL : ATO7

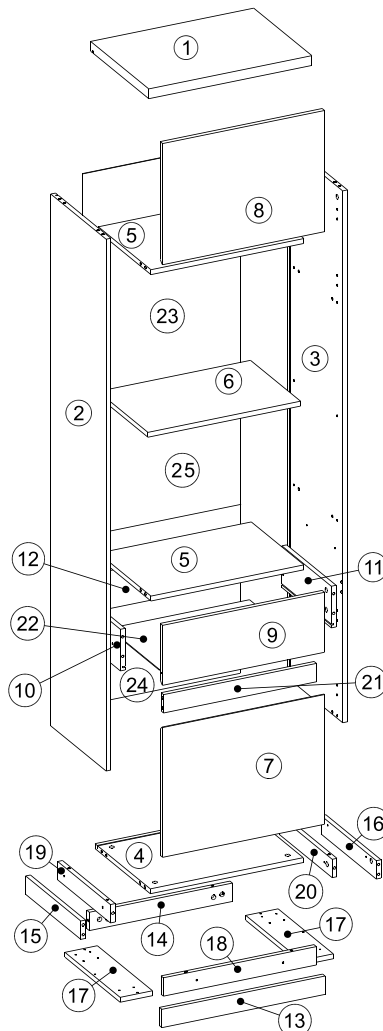

25	710x525	1/3
24	638x525	1/3
23	387x525	1/3
22	336x468	1/3
21	510x60	2/3
20	352x60	2/3
19	352x60	2/3
18	510x60	2/3
17	368x108	2/3
16	368x60	2/3
15	368x60	2/3
14	477x60	2/3
13	544x60	2/3
12	453x124	2/3
11	330x136	2/3
10	330x136	2/3
9	540x196	3/3
8	396x540	3/3
7	424x540	3/3
6	509x334	1/3
5	510x351	1/3
4	510x369	1/3
3	1738x369	2/3
2	1738x369	2/3
1	545x388	1/3

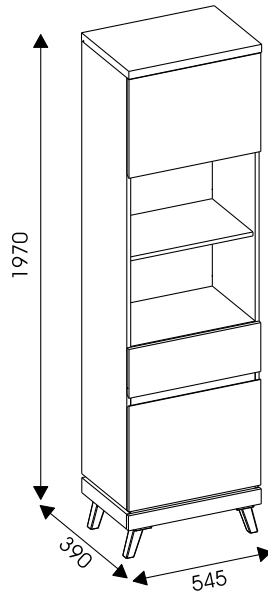
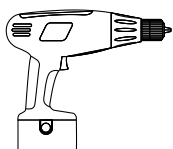
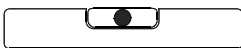
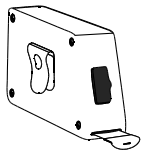
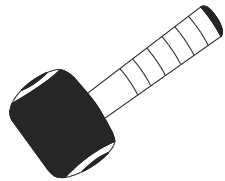
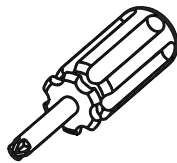
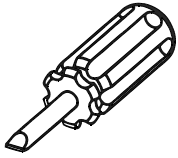
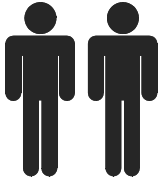
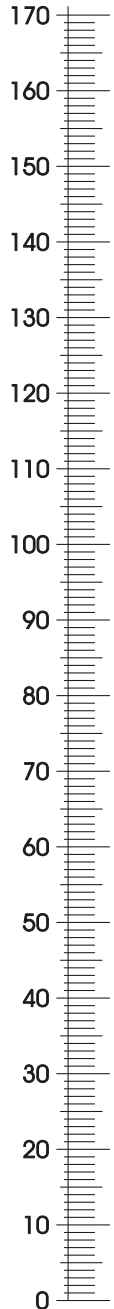

4x ZW000235X ZP1	1x LK008121S L1	8x BS1						
16x #20/981 ZN1	10x 3.5x16 W3	14x ST1	1 kpl. #300 PK3	4x B1	14x 3x20 W9	4x ZC90	16x 4x30 W4	4x N1
4x 6.4x50 K5	26x 8x30 K1	4x Z10	1x K20	30x #15/15 M1	30x DU232T T1	12x 3.5x20 W8	13x 2x20 G1	8x 5x11 E1

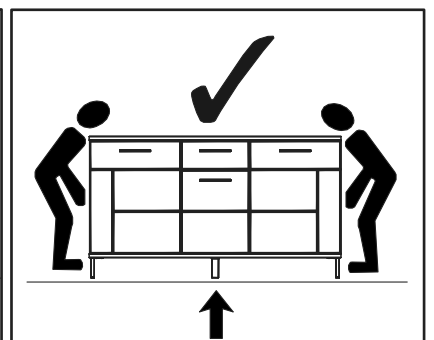
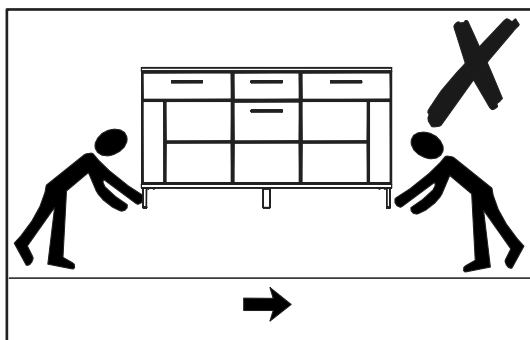
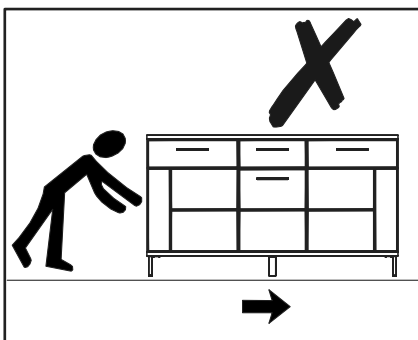
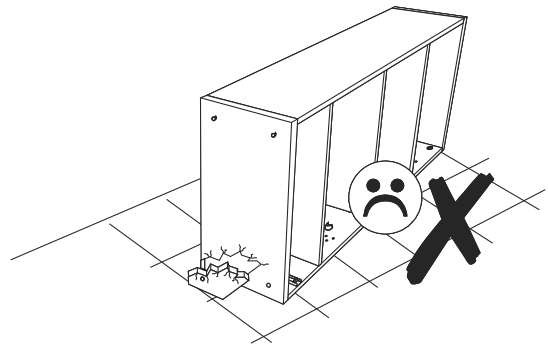
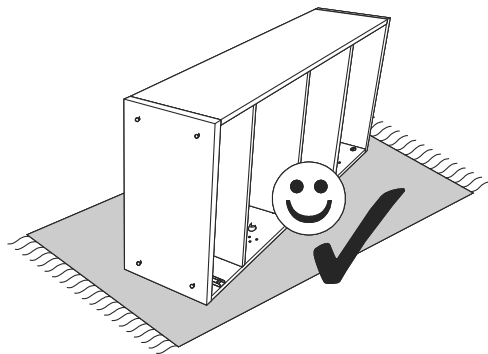
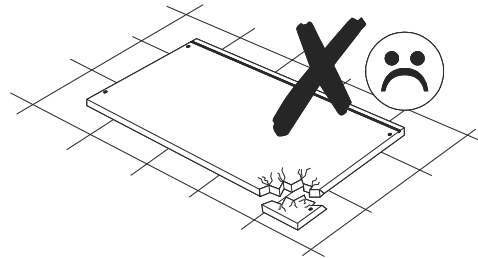
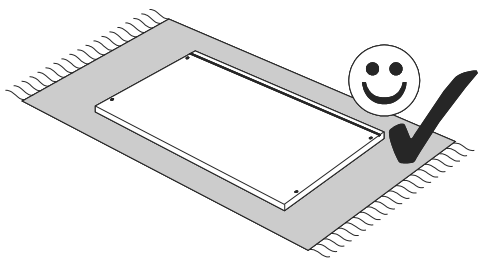
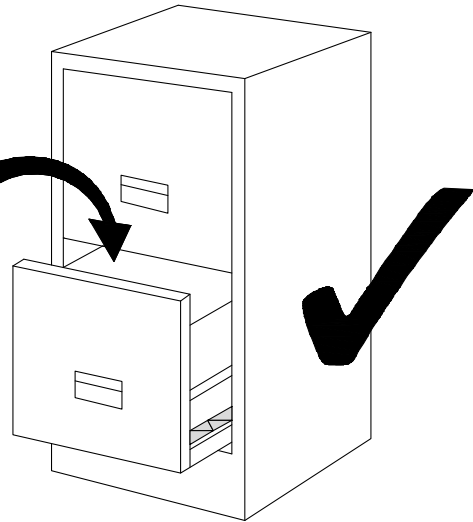
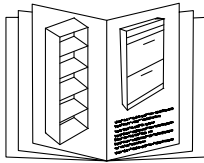
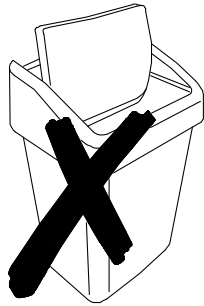

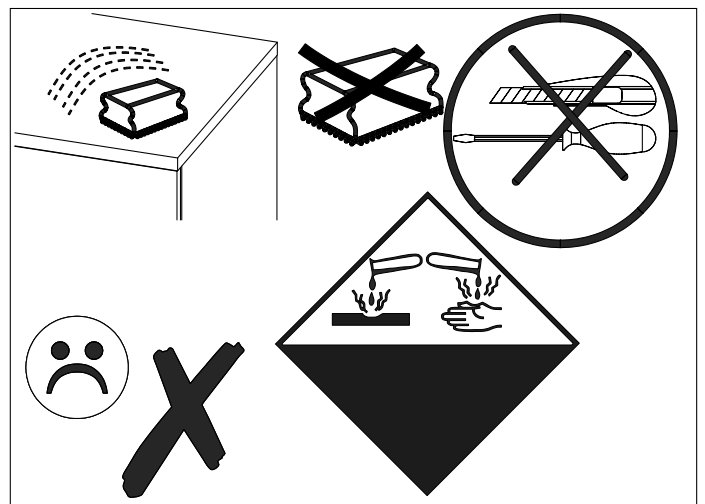
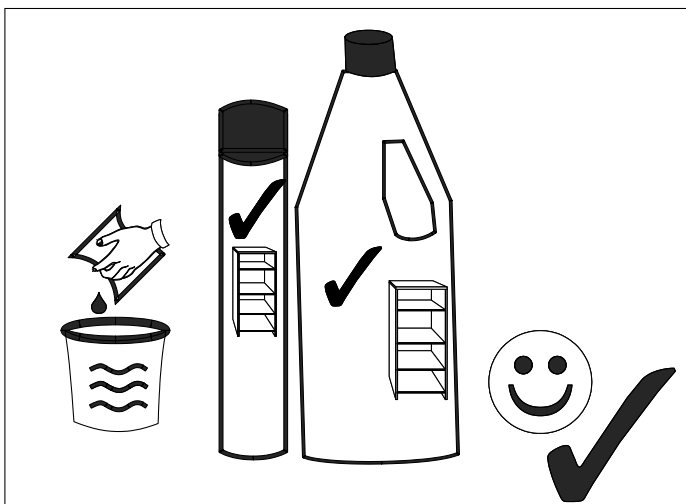
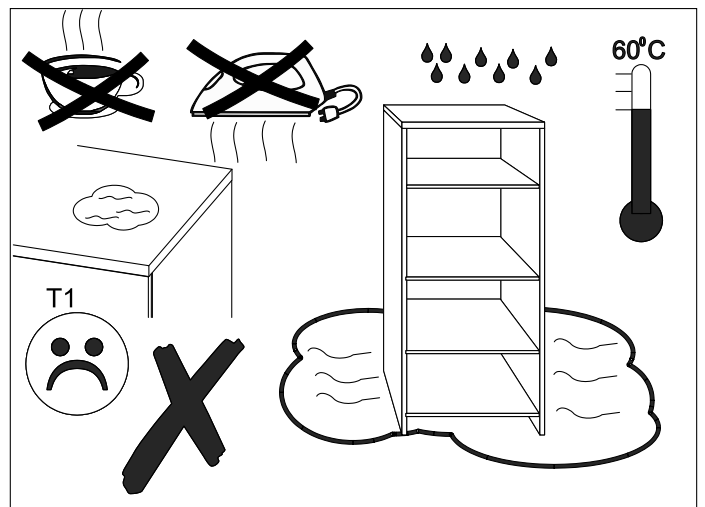
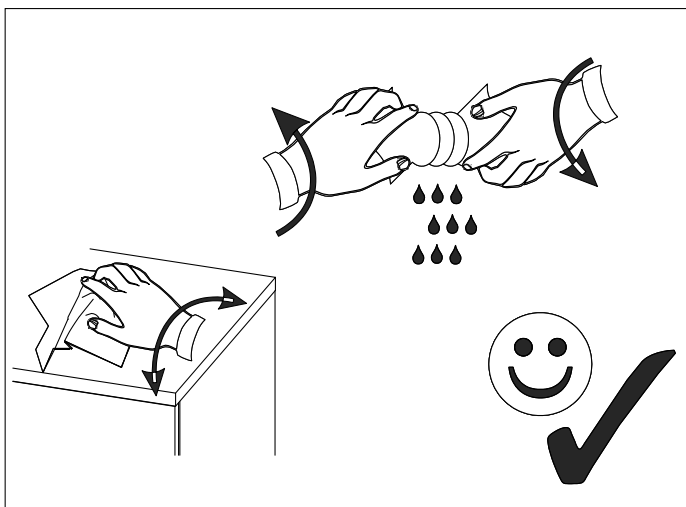
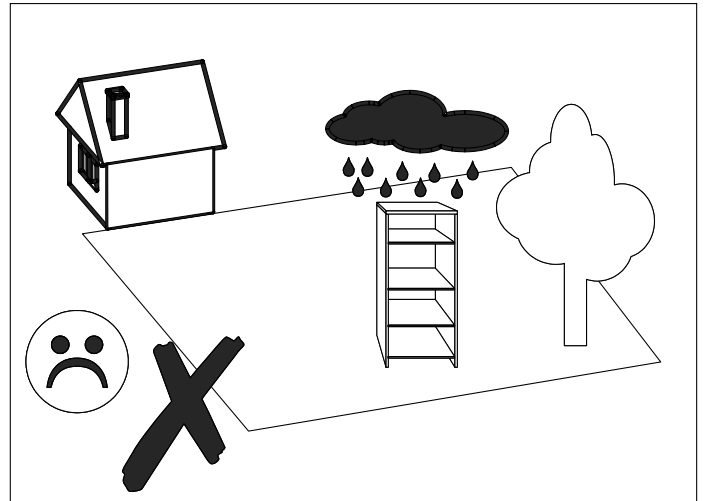
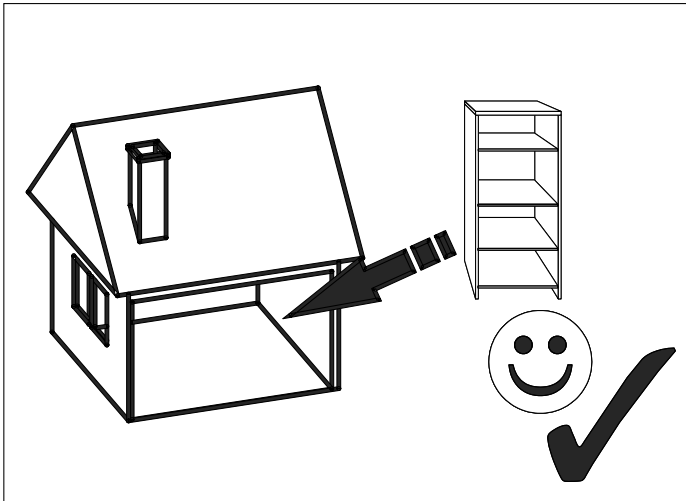
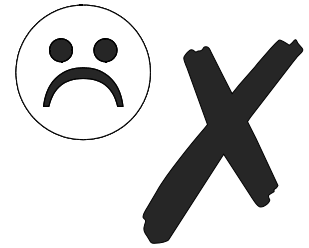

1

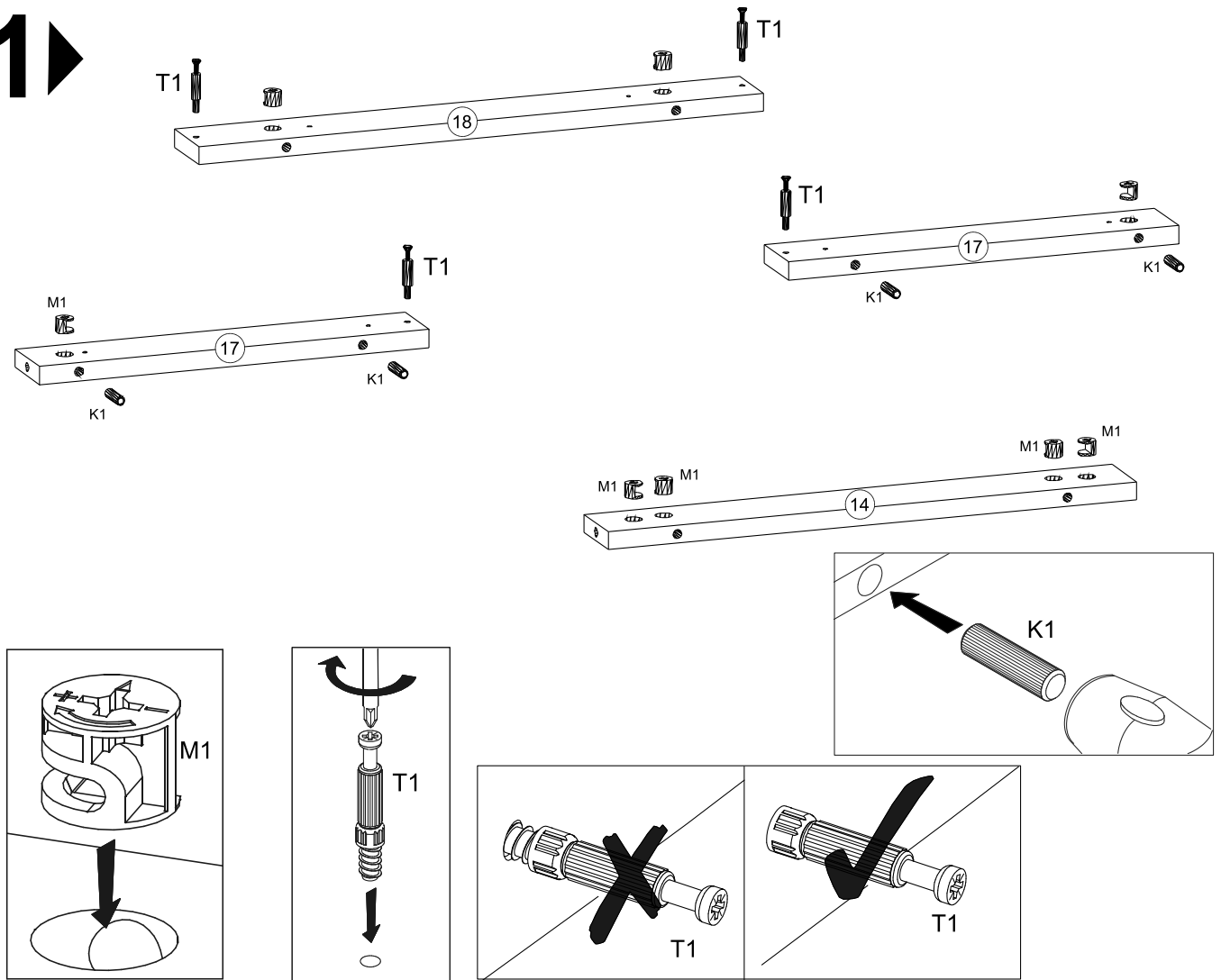

2

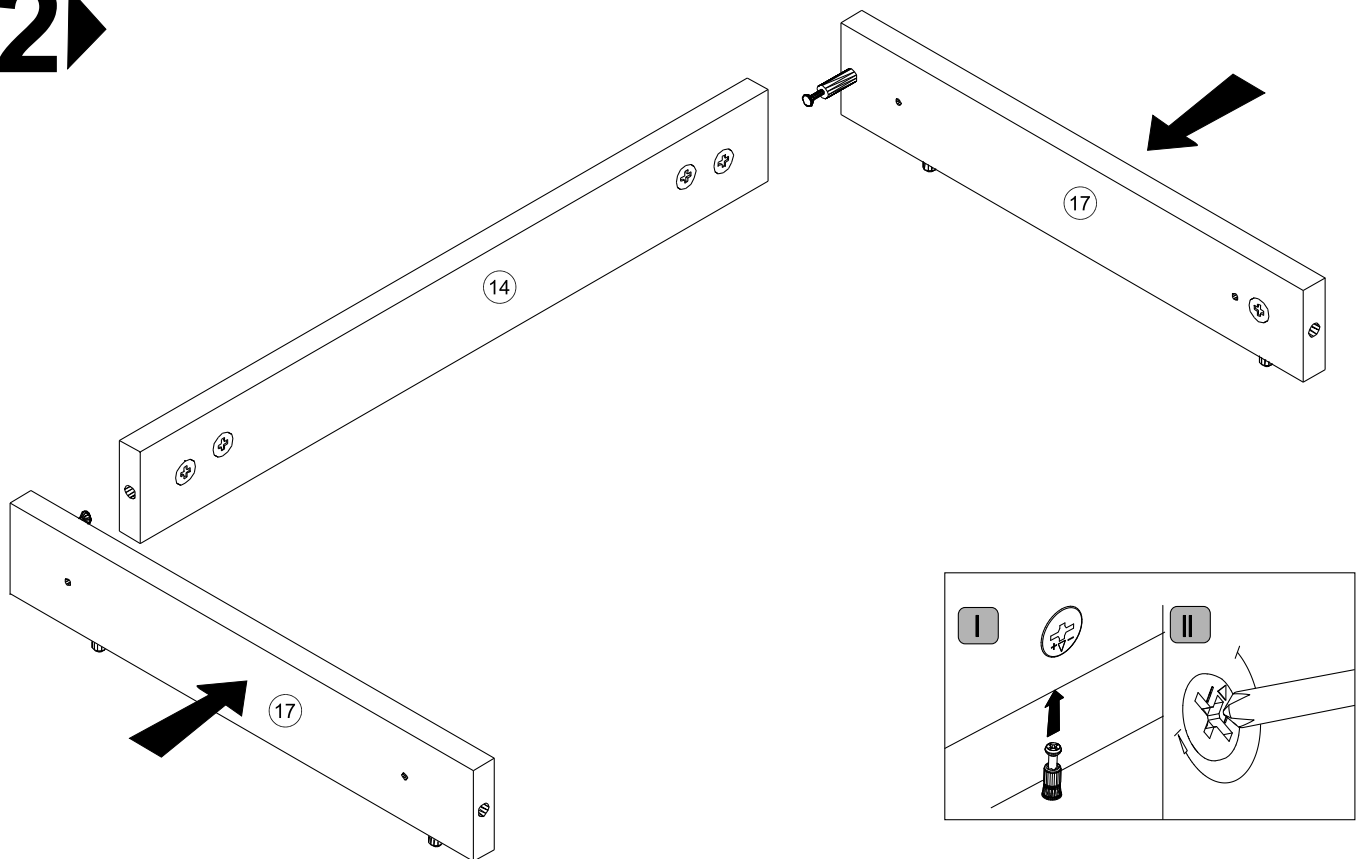

3

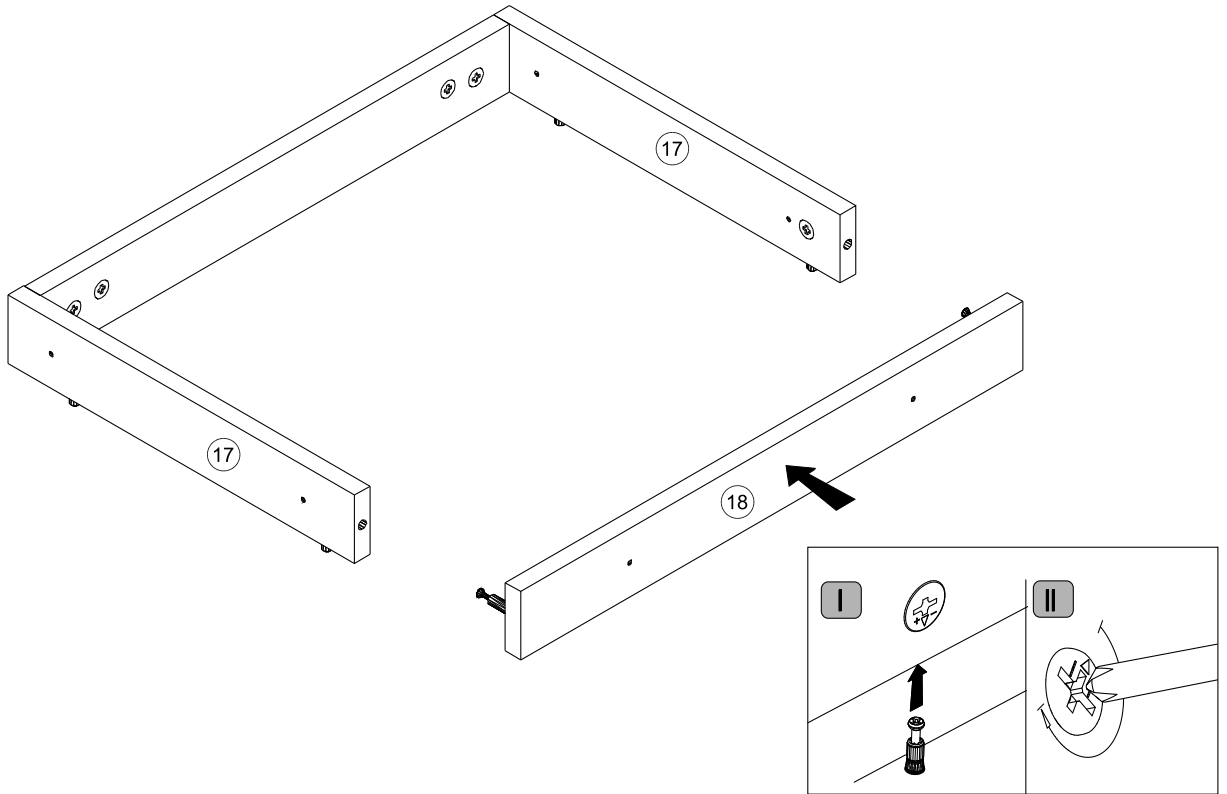

4

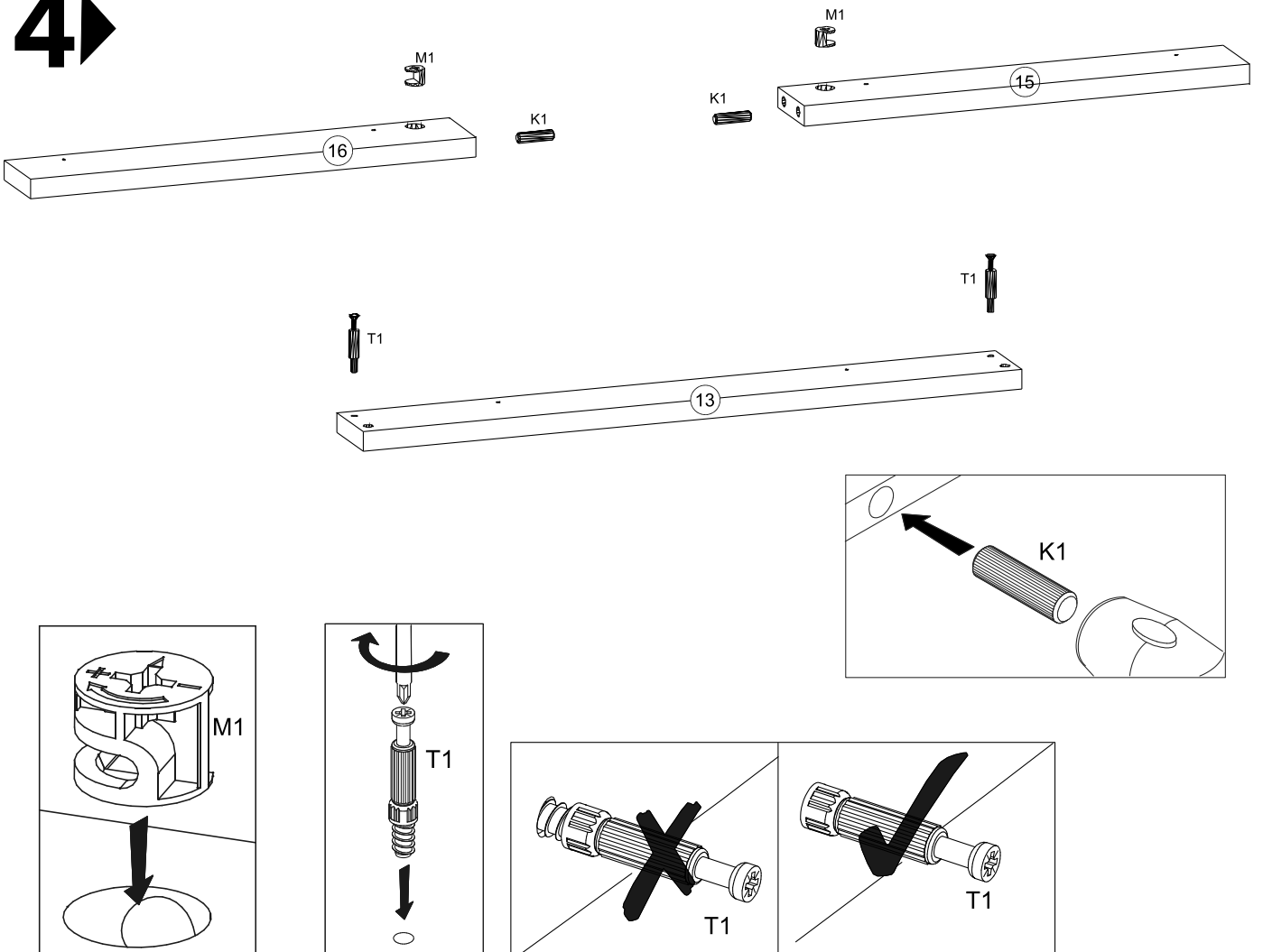

5

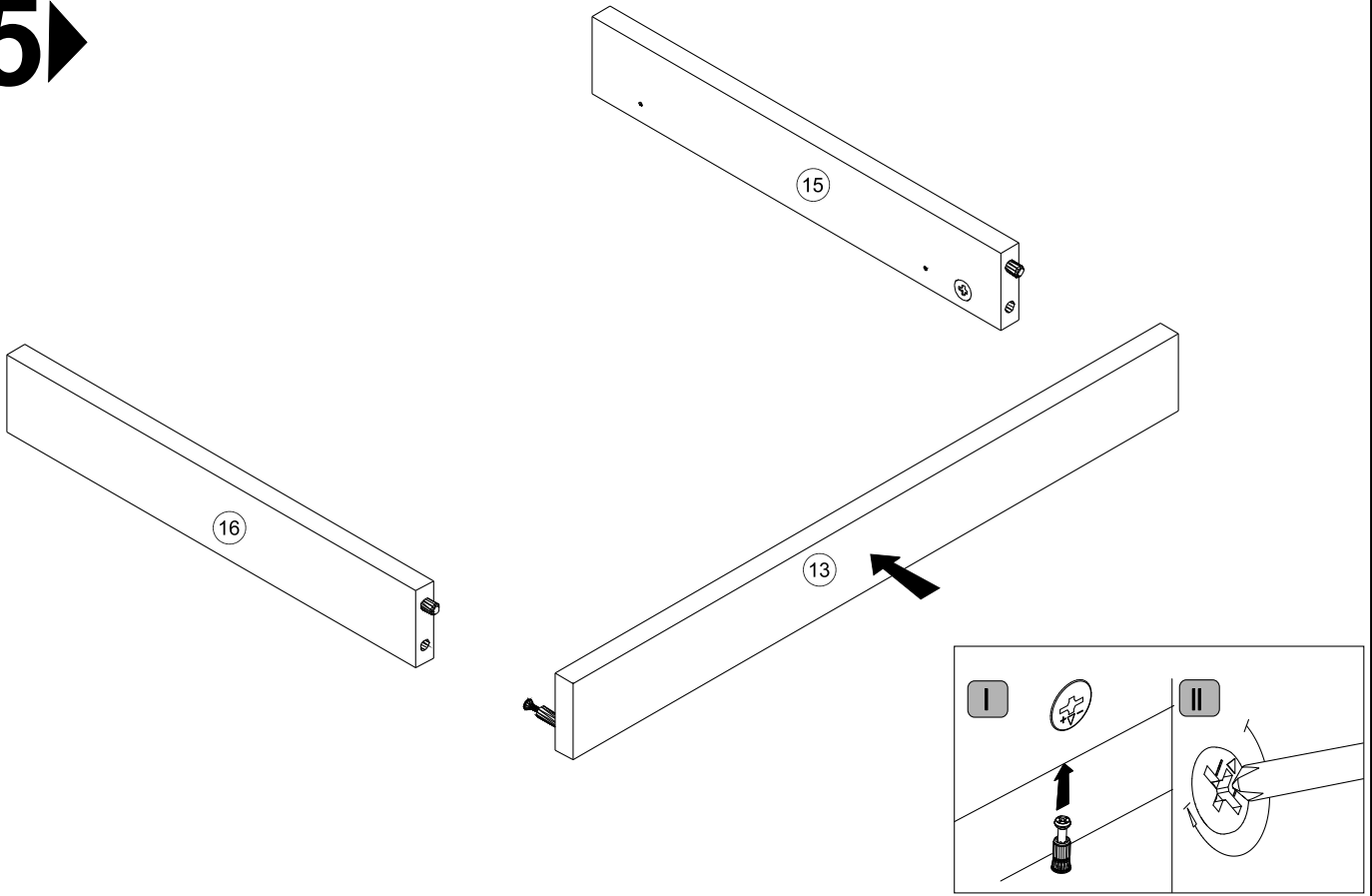

6

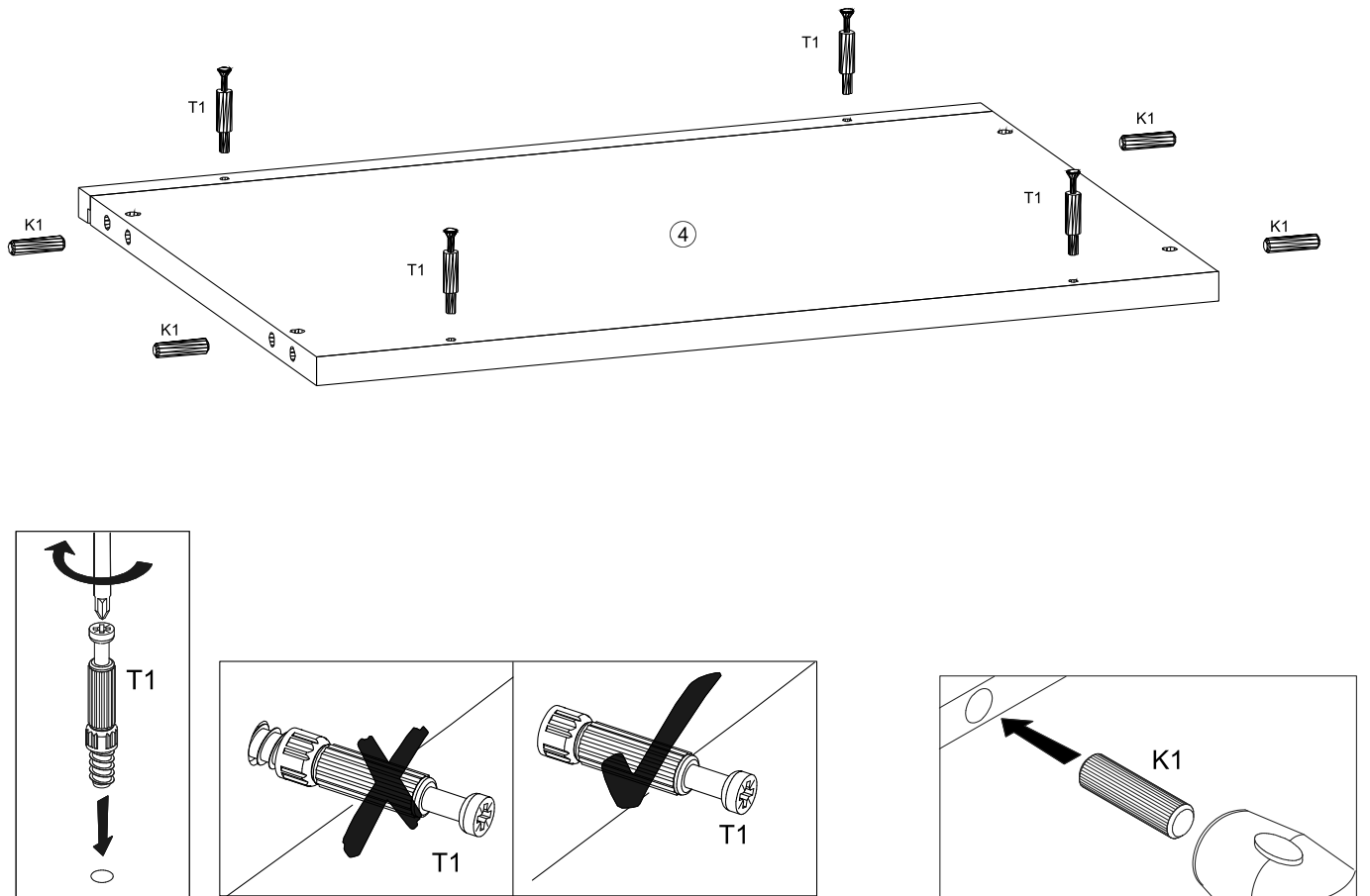

7

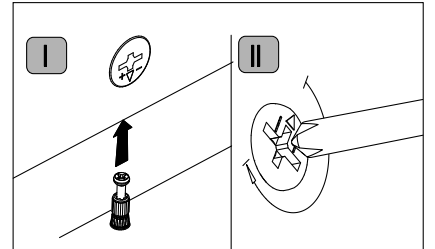
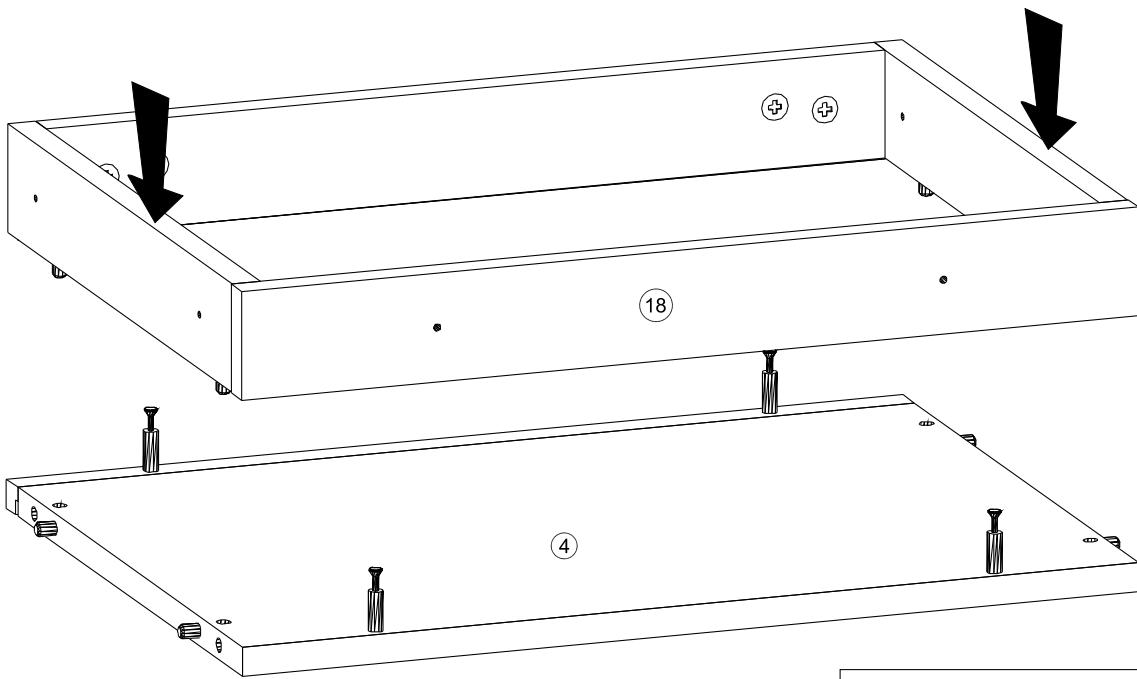

8

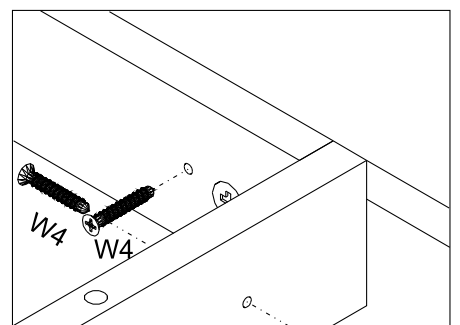
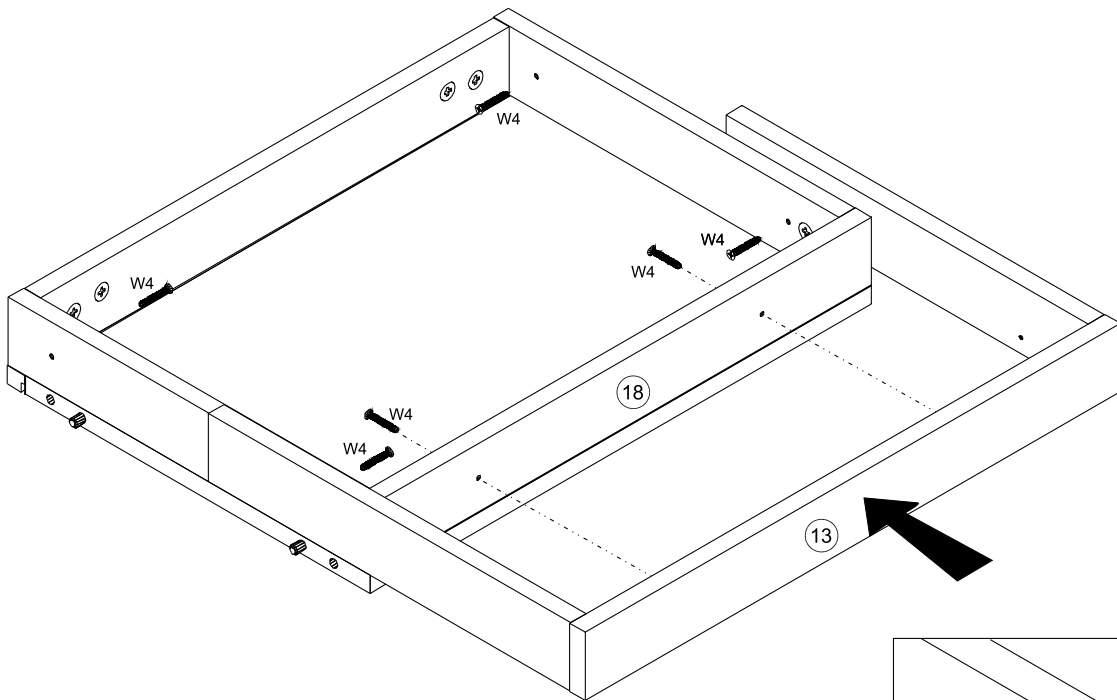

9 ▶

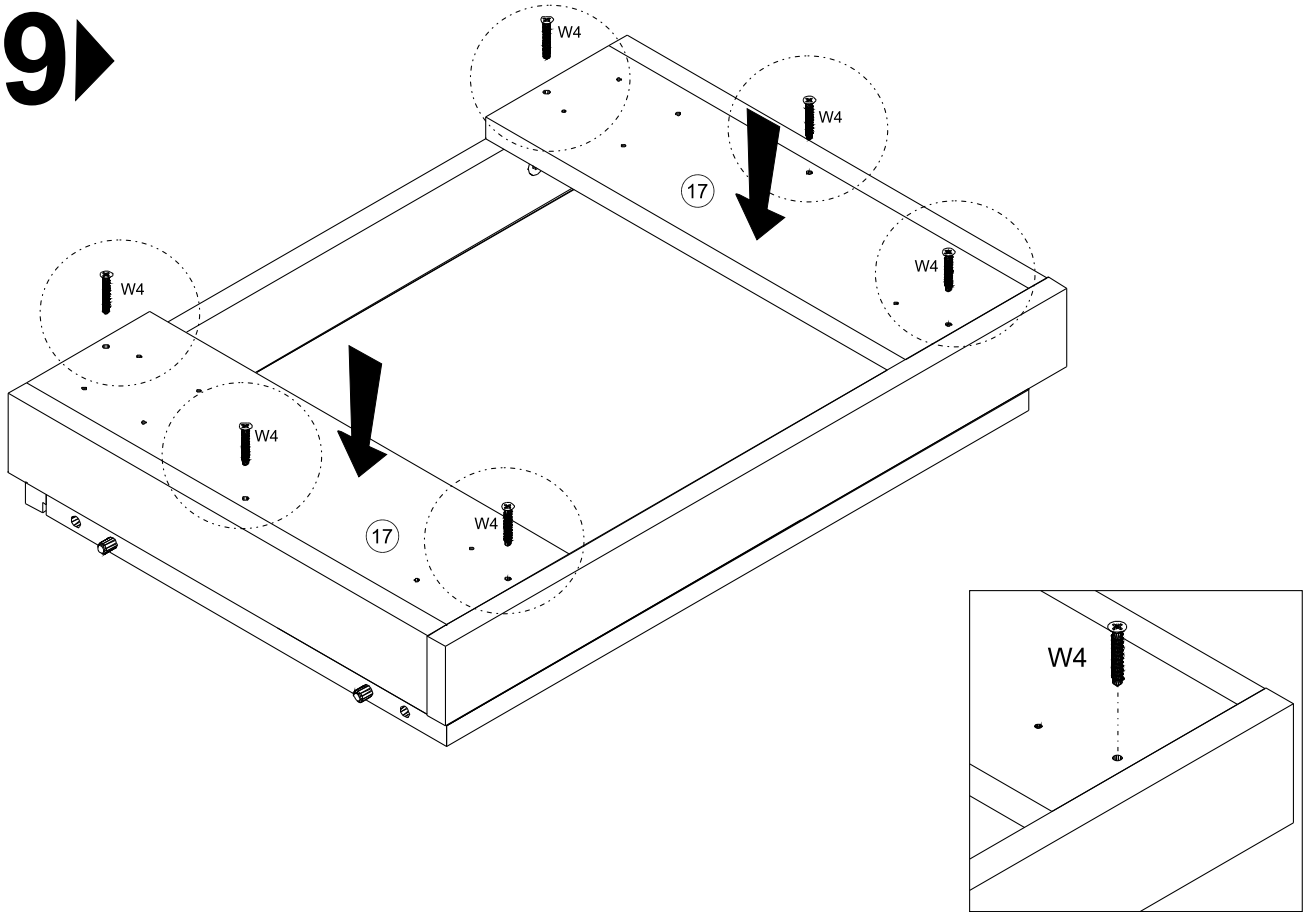

10 ▶

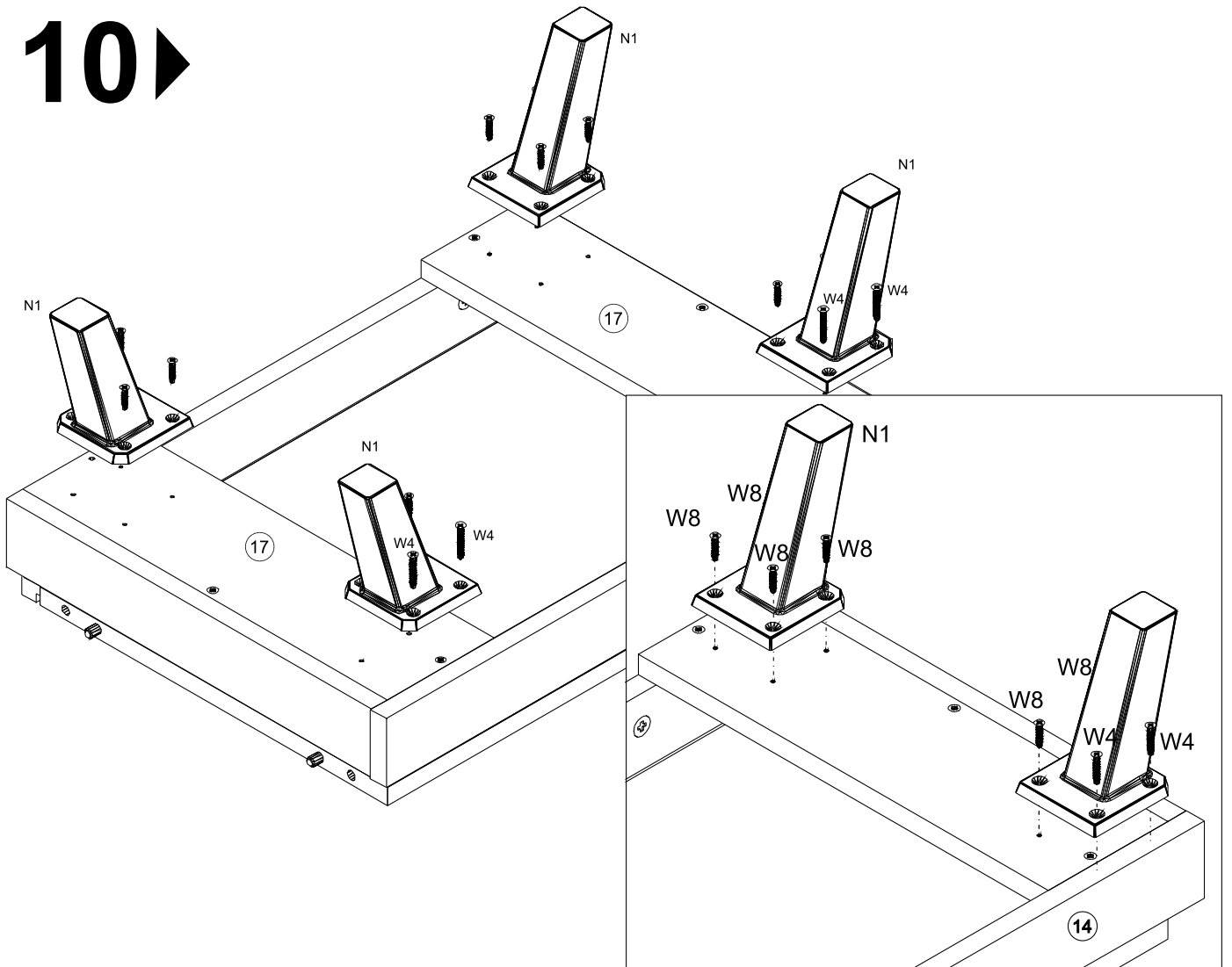

11 ▶

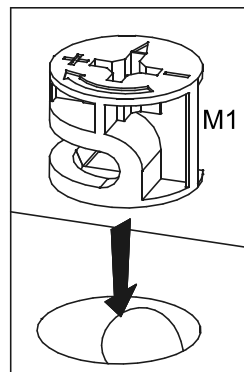
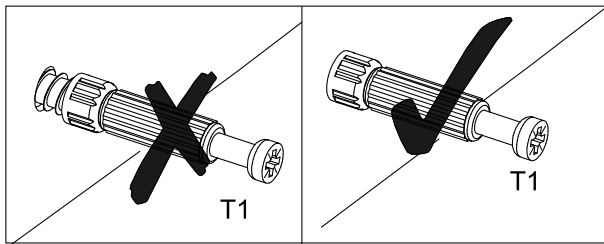
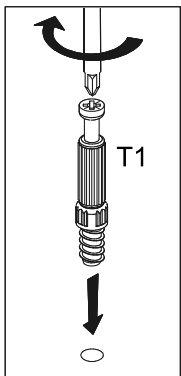
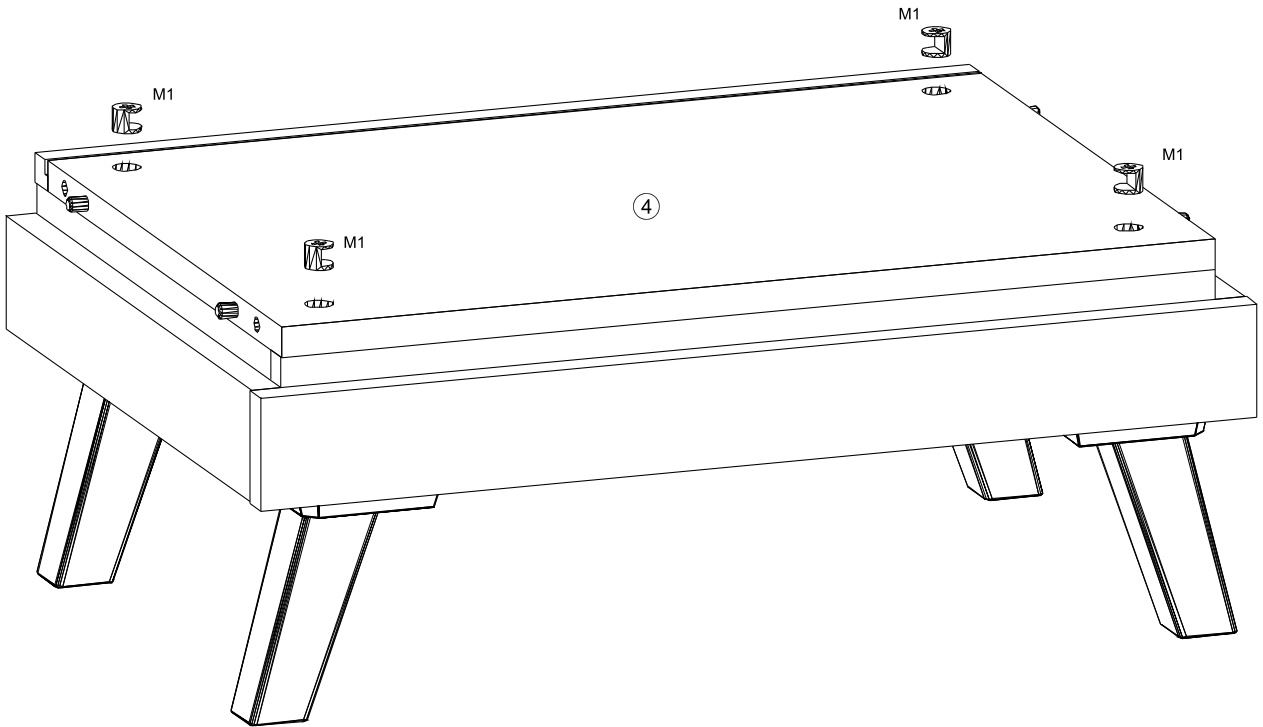

12 ▶

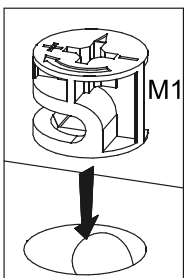
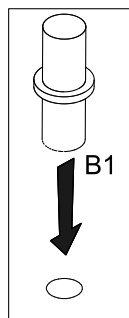
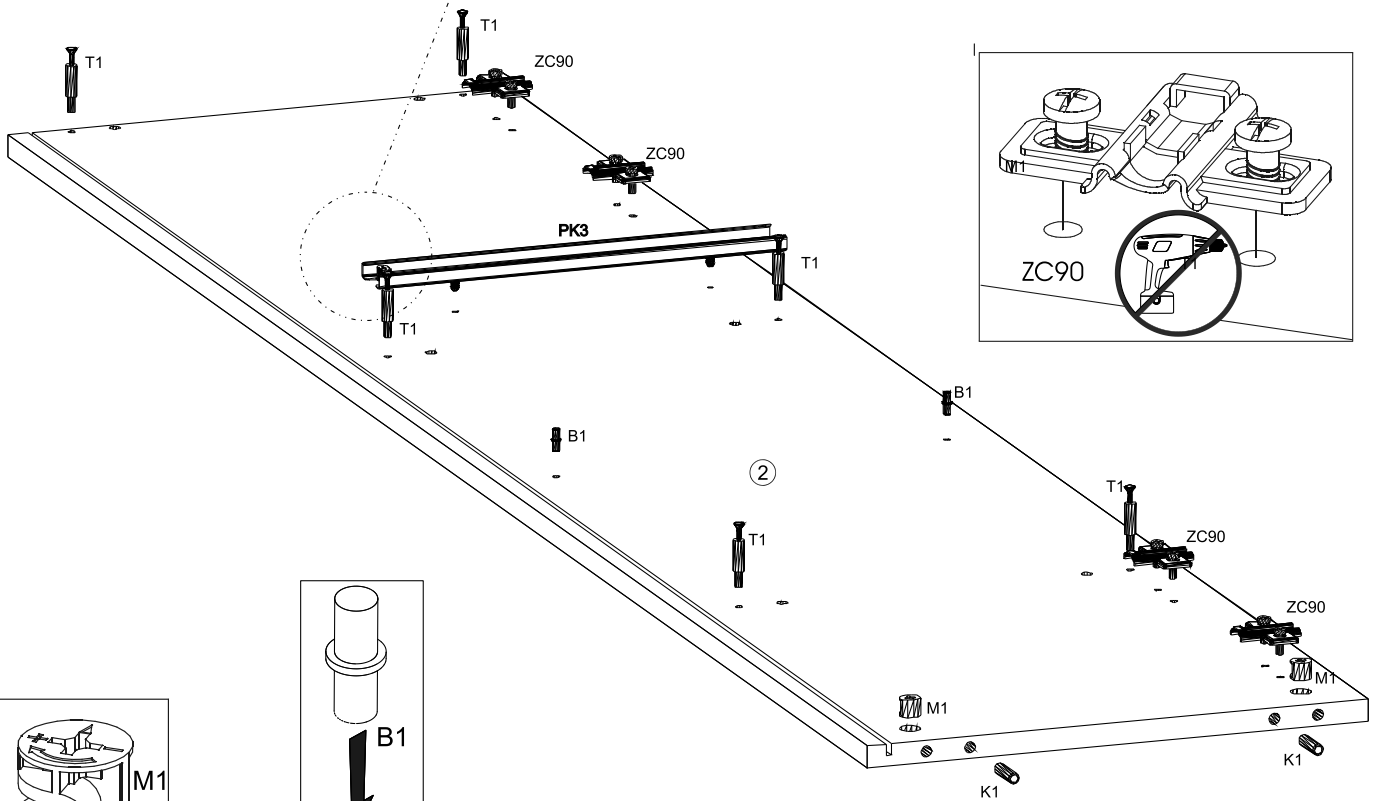
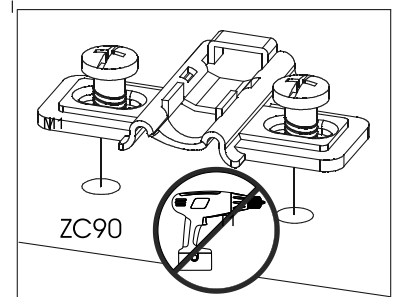
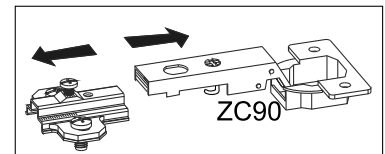
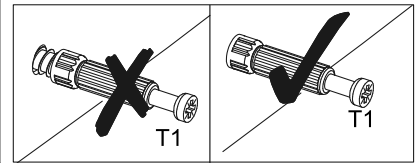
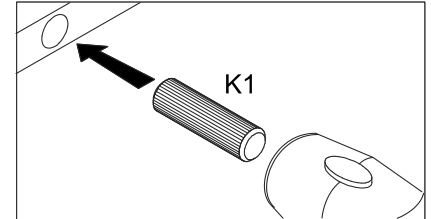
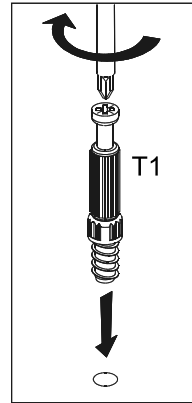
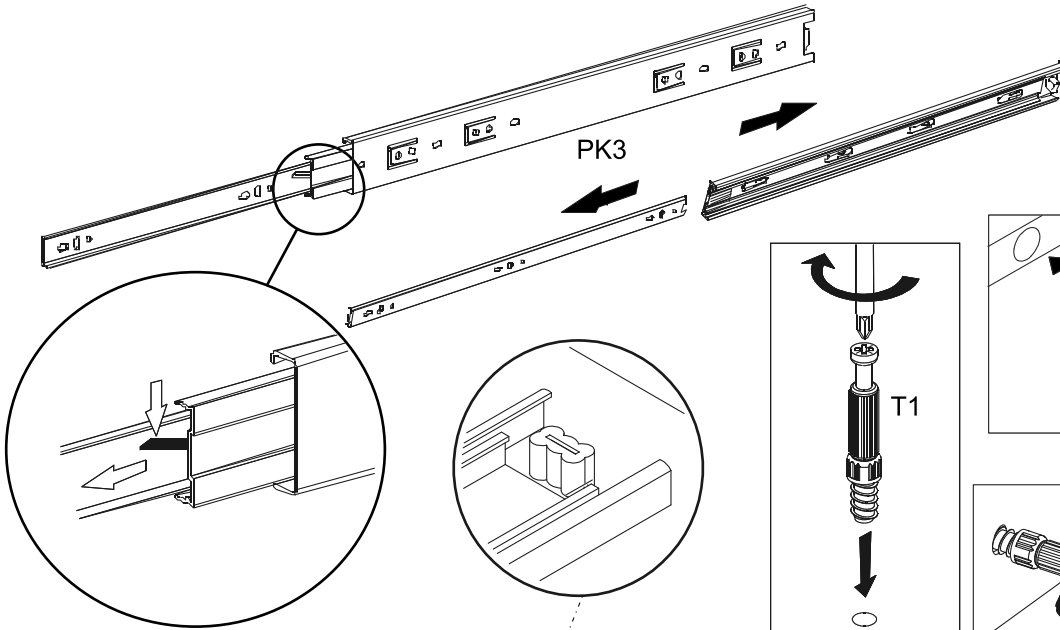
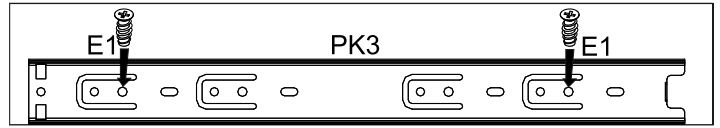

13 ▶

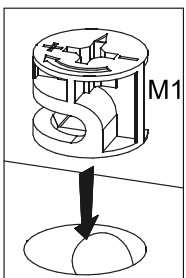
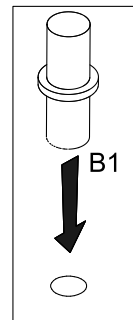
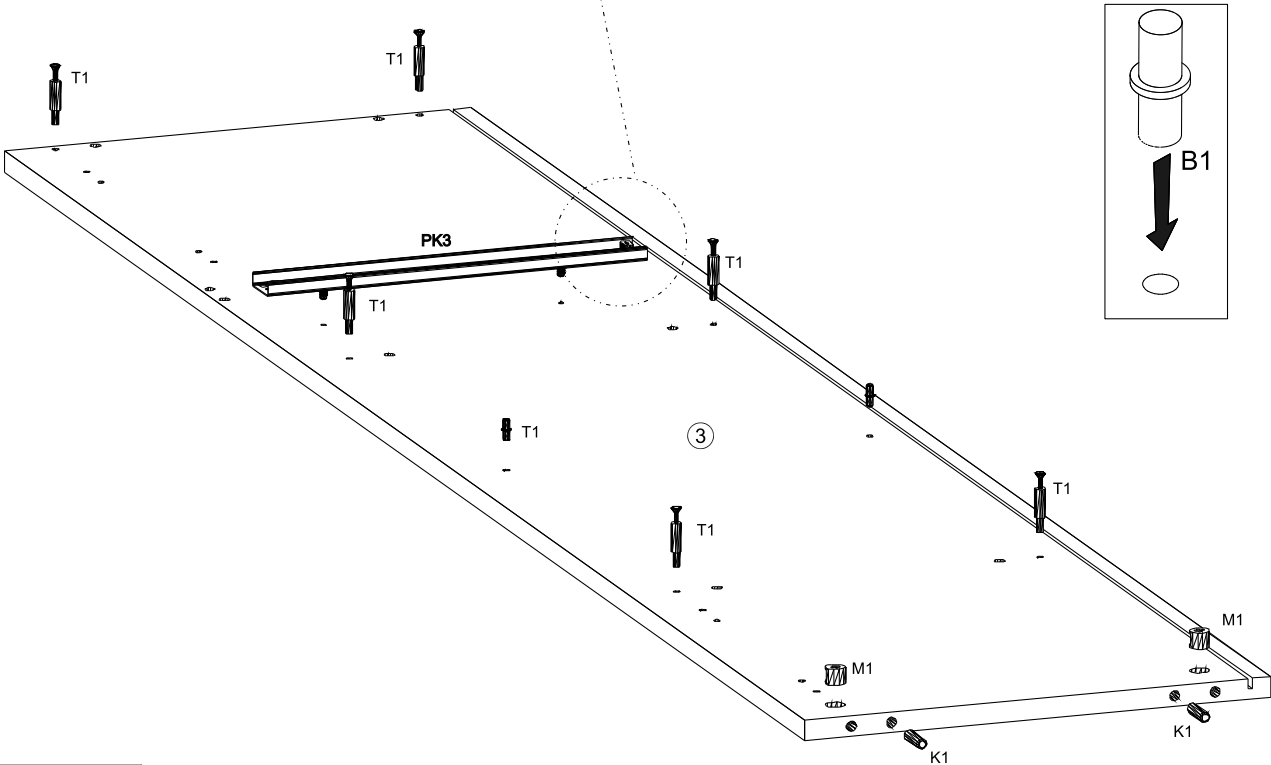
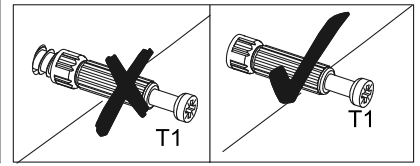
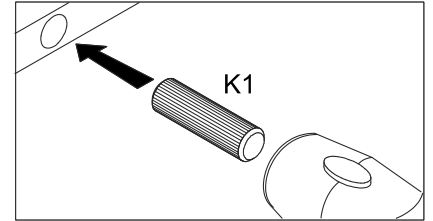
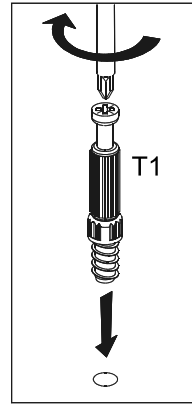
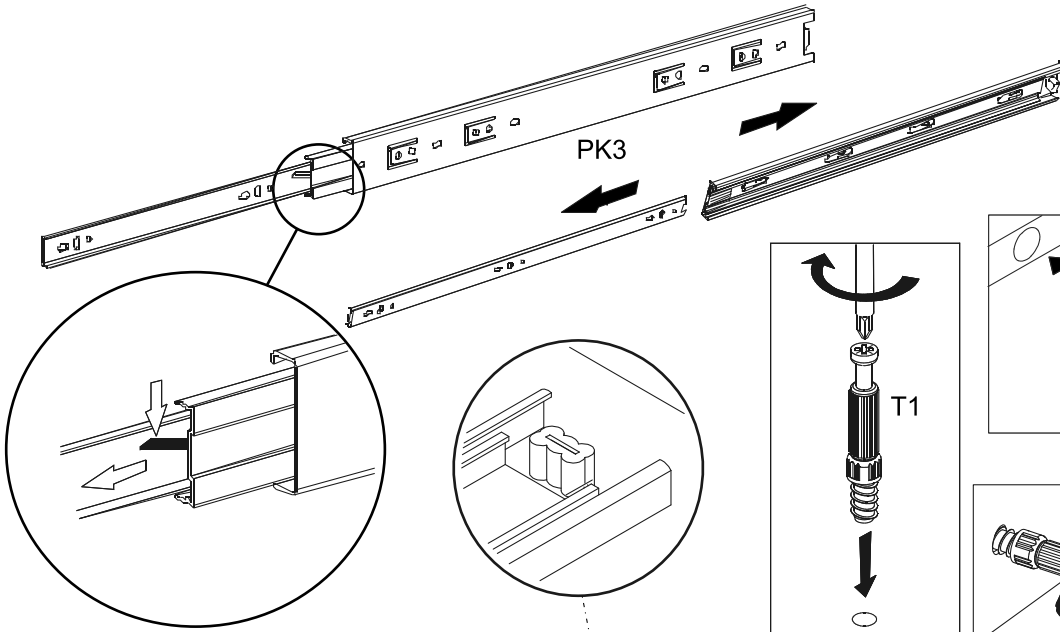
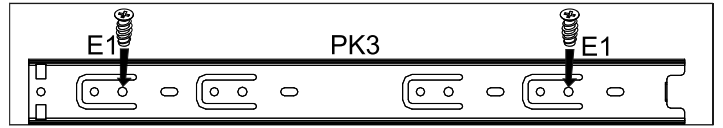

14▶

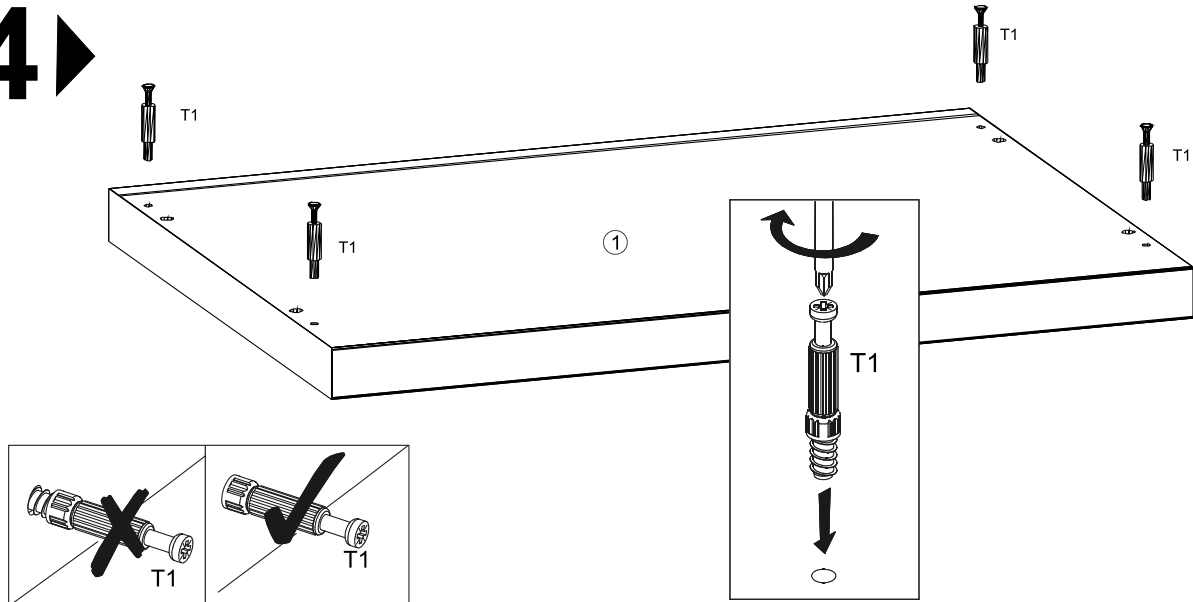

15▶

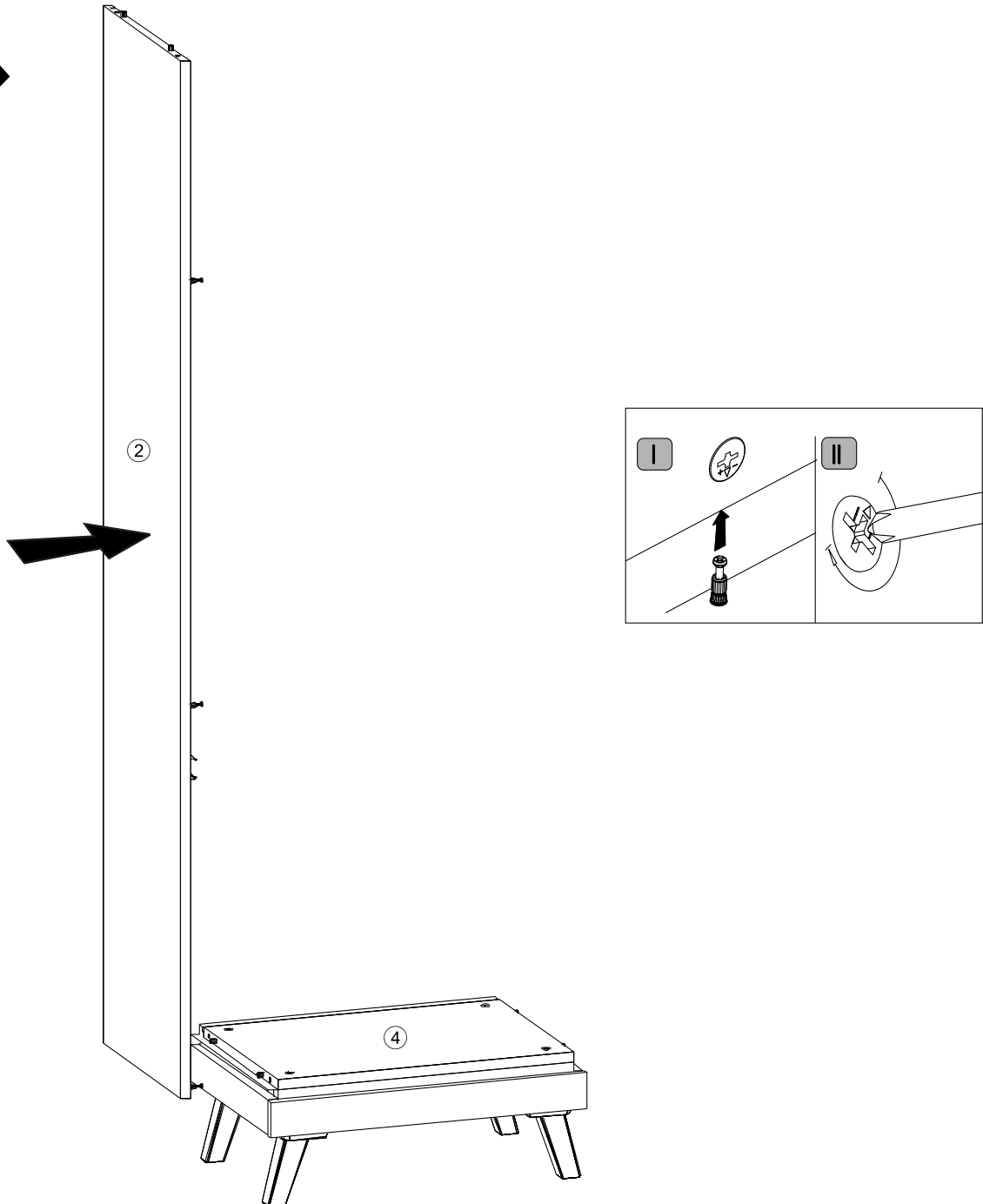

16 ▶

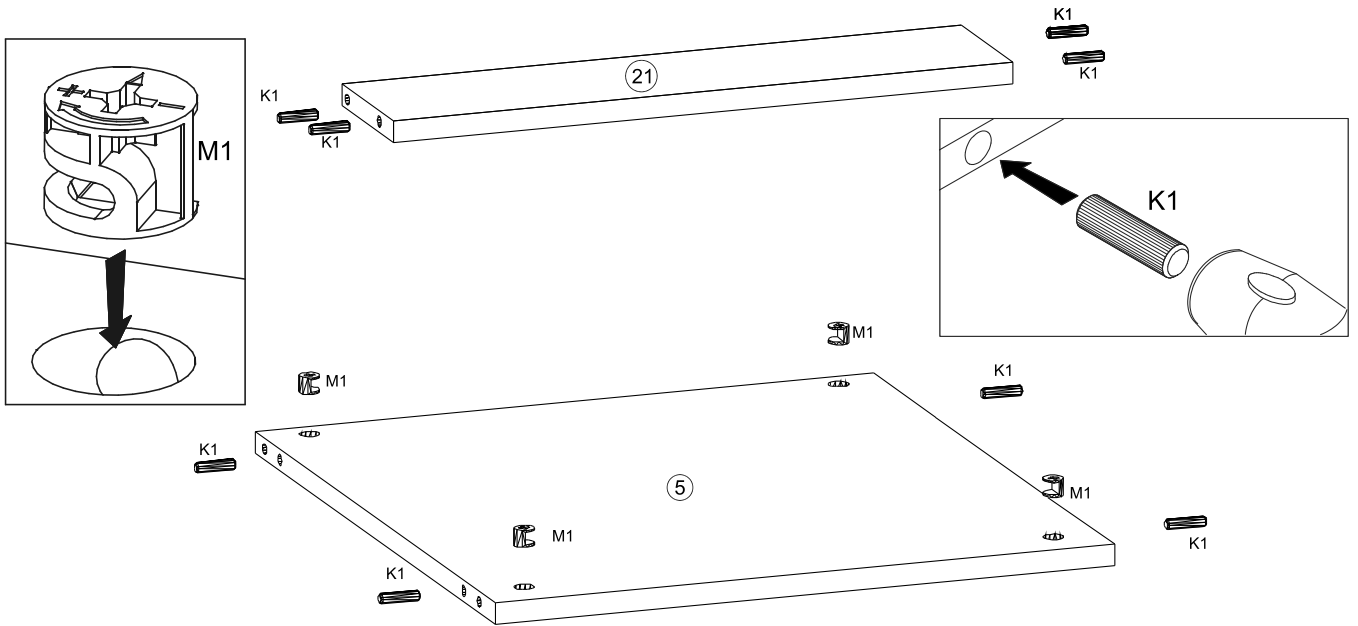

17 ▶

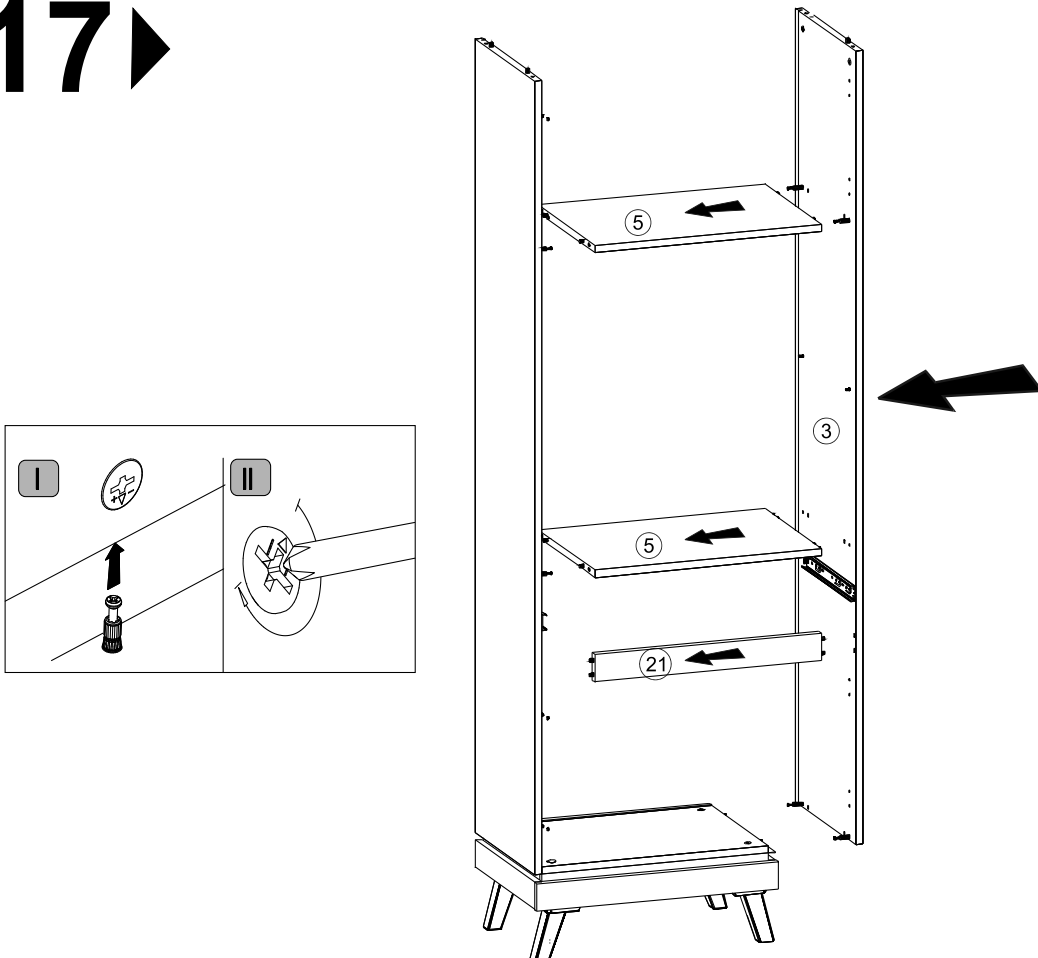

18 ▶

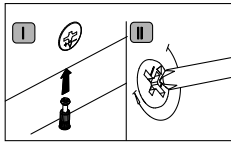
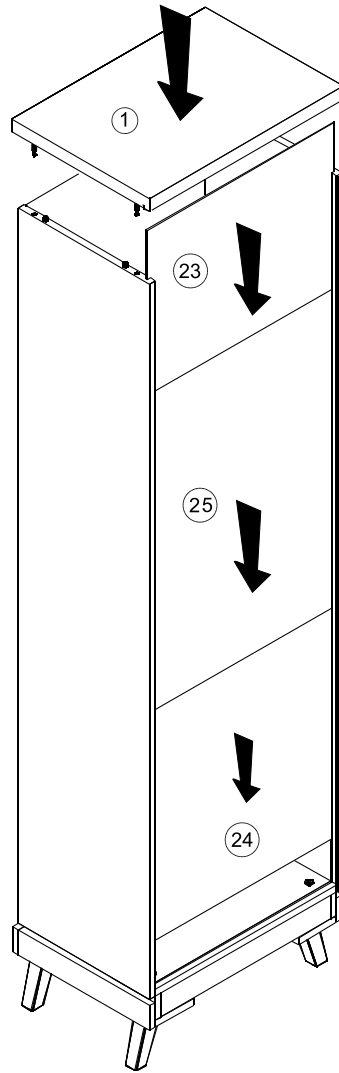

19 ▶

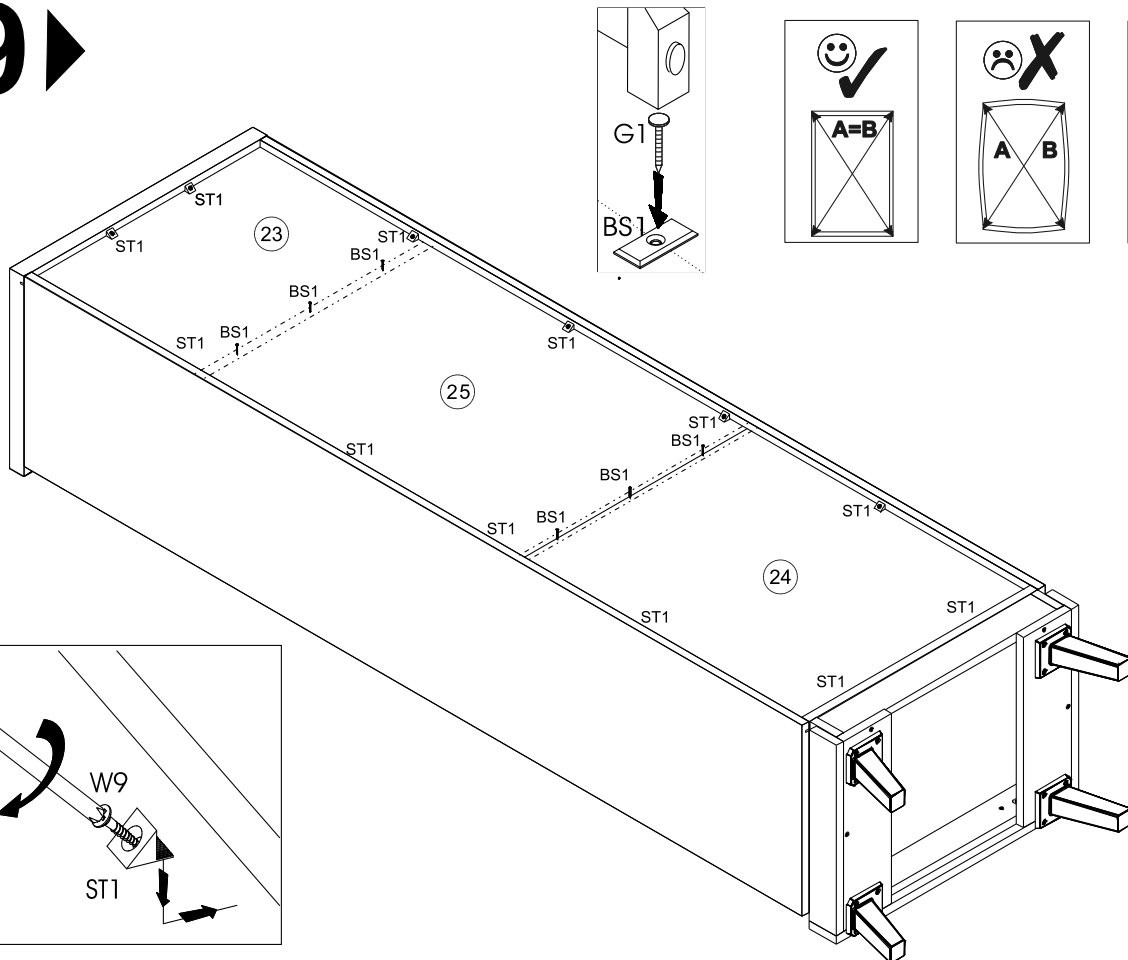

20 ▶

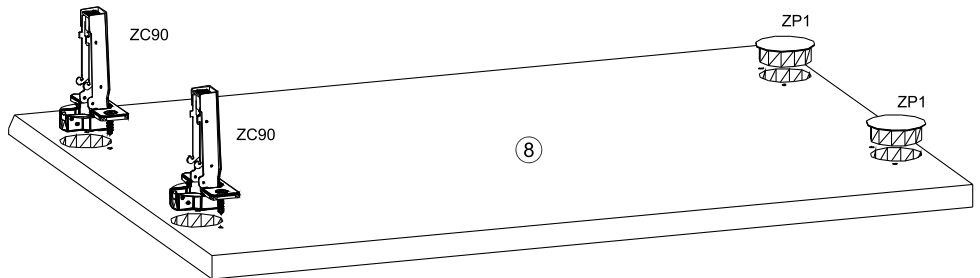
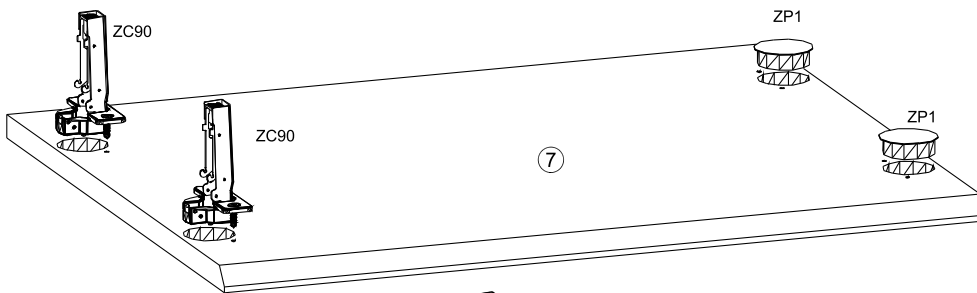
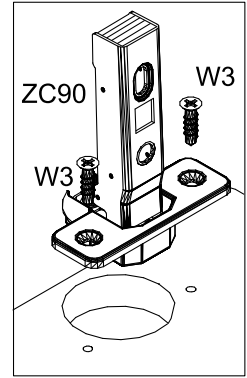
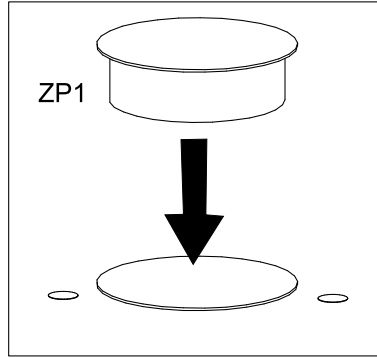
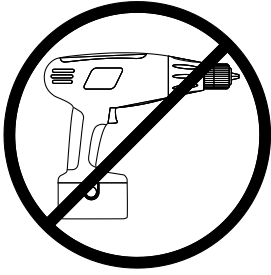

21 ▶

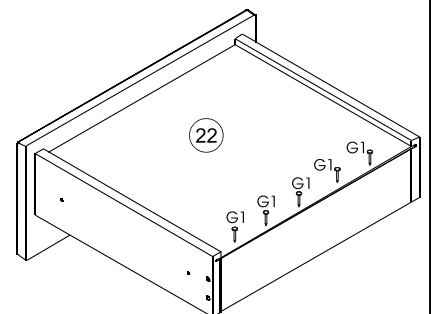
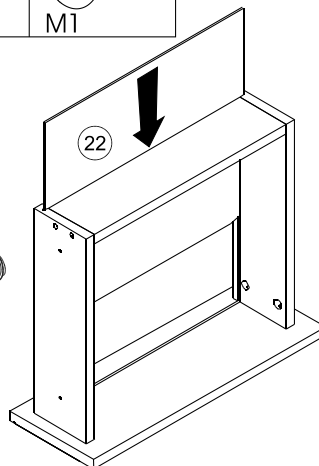
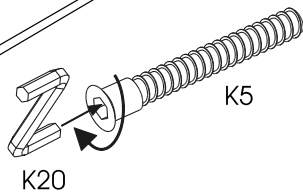
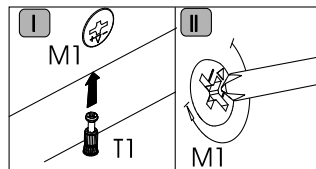
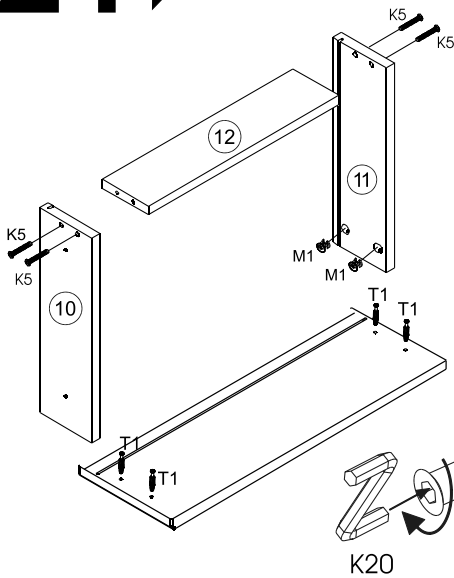

22

