

# MONTÁŽNÍ/MONTÁŽNY NÁVOD

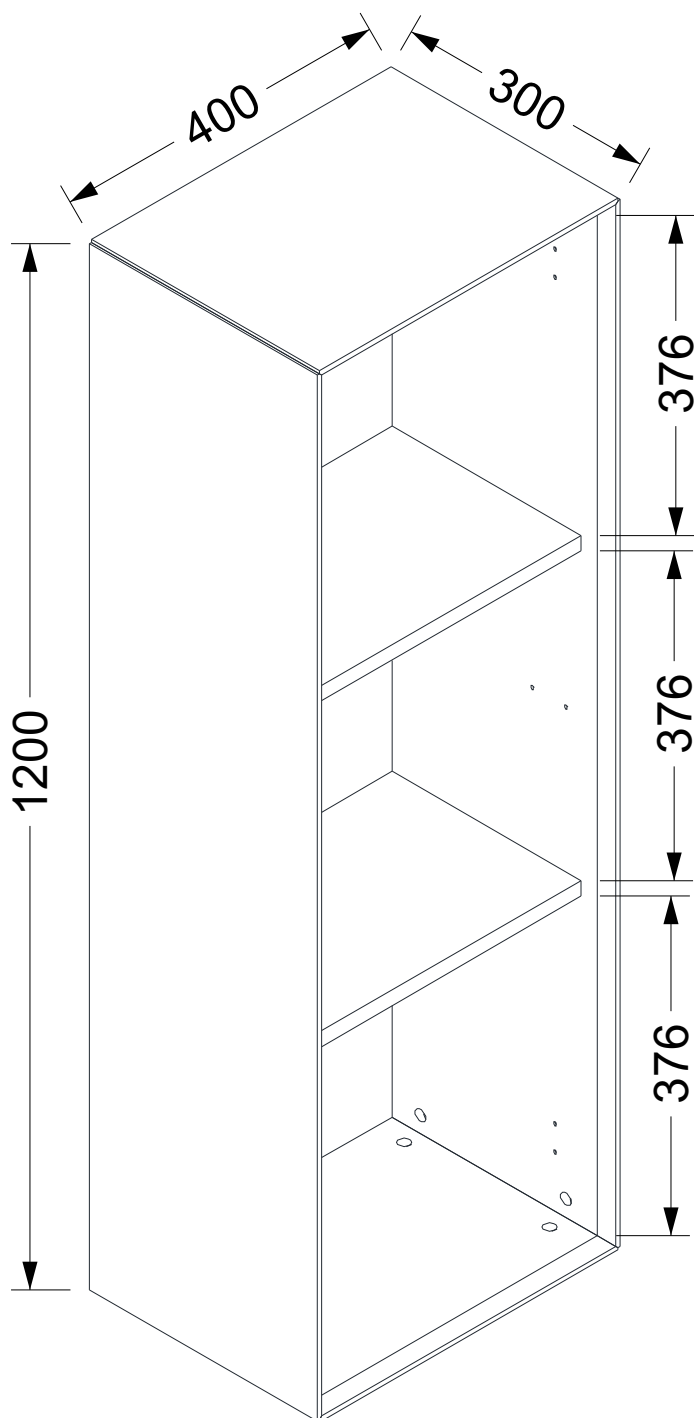

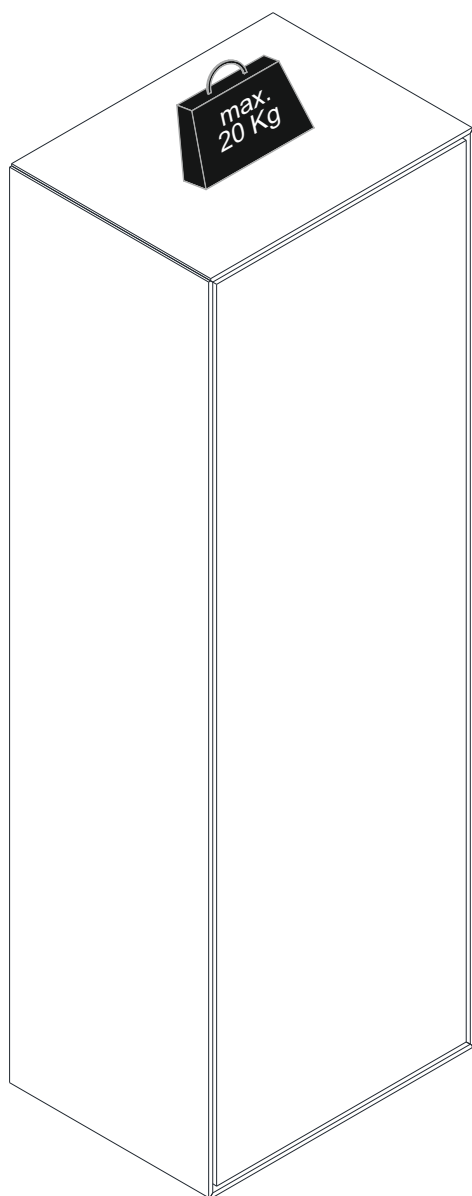
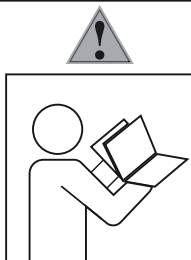

- Ⓓ Befolgen Sie stets die Anleitung des Herstellers!
- Ⓖ Please generally follow the manufacturer's instructions!
- Ⓕ Suivez toujours les instructions du fabricant!
- Ⓓ Volg steeds de handleiding van de producent!
- Ⓔ Siga siempre las instrucciones del fabricante!
- Ⓒ Stale przestrzegaj instrukcji producenta!

- ⒲ Всегда следуйте инструкции производителя!
- Ⓙ Seguire sempre le istruzioni del produttore!
- Ⓔ Mindig tartsa be a gyártó utasításait!
- Ⓖ Siga sempre as instruções do fabricante!
- Ⓒ Vždy dodržujte pokyny výrobce!
- Ⓒ Vždy dodržujte pokyny výrobcu!

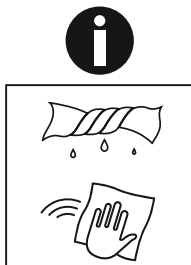

- Ⓓ Verwenden Sie zur Reinigung nur ein feuchtes Tuch!
- Ⓖ Please only clean with a damp cloth!
- Ⓕ N'utilisez qu'un chiffon humide pour le nettoyage!
- Ⓓ Gebruik voor de reiniging enkel een vochtige doek!
- Ⓔ Para limpiar utilice sólo un paño húmedo!
- Ⓒ Do czyszczenia używaj wilgotnej szmatki!

- ⒲ Для очистки используйте только влажную ткань!
- Ⓙ Per la pulizia, utilizzare solo un panno umido!
- Ⓔ A tisztításhoz elegendő egy nedves kendő használatát!
- Ⓖ Para a limpeza use apenas um pano húmido!
- Ⓒ Pro čištění používejte pouze vlhký hadřík!
- Ⓒ Na čistenie používajte iba vlhkú handričku!

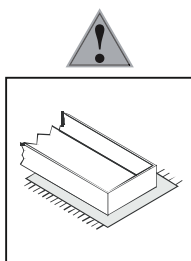

- Ⓓ Bauen Sie das Produkt auf einer Unterlage auf!
- Ⓖ Please mount the product on a bottom support!
- Ⓕ Montez le produit sur une base!
- Ⓓ Monteer het product op een basis!
- Ⓔ Monte el producto sobre una base!
- Ⓒ Rozkładaj produkt na podkładce!

- ⒲ Собирайте изделие на подстилке!
- Ⓙ Montare il prodotto su un supporto!
- Ⓔ Az összeszereléskor helyezzen a termék alá megfelelő alátétet!
- Ⓖ Monte o produto numa superfície plana!
- Ⓒ Výrobek smontujte na pevném podkladu!
- Ⓒ Výrobok zmontujte na pevnom podklade!

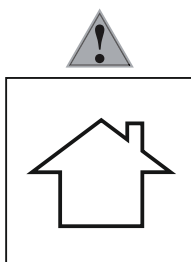

- Ⓓ Verwenden Sie das Produkt nur in Innenräumen!
- Ⓖ Please exclusively use the product indoors!
- Ⓕ N'utilisez le produit qu'à l'intérieur!
- Ⓓ Gebruik het product enkel binnenshuis!
- Ⓔ Utilice el producto sólo en interiores!
- Ⓒ Używaj produkt tylko w pomieszczeniach wewnętrznych!

- ⒲ Используйте изделие только во внутренних помещениях!
- Ⓙ Utilizzare il prodotto solo in ambienti interni!
- Ⓔ A termék csak bel terekben használható!
- Ⓖ Use o produto apenas no interior!
- Ⓒ Používejte výrobek pouze uvnitř!
- Ⓒ Výrobok používajte len vo vnútri!

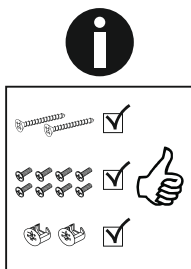

- Ⓓ Legen Sie die Beschläge zusammen und prüfen Sie die Vollständigkeit!
- Ⓖ Please join the fittings and verify their completeness!
- Ⓕ Pliez les raccords ensemble et vérifiez qu'ils sont complets!
- Ⓓ Leg de onderdelen samen en controleer de volledigheid!
- Ⓔ Junte los accesorios y compruebe que están todos!
- Ⓒ Rozłóż poszczególne części i sprawdź kompletność!

- ⒲ Положите фурнитуру в одно место и проверьте комплектность!
- Ⓙ Mettere insieme le garnizioni e verificarne la completezza!
- Ⓔ Állítsa össze a sarokvasakat, és ellenőrizze, hogy épek-e!
- Ⓖ Coloque os encaixes juntos e verifique se estão completos!
- Ⓒ Složte armatury a zkontrolujte úplnost!
- Ⓒ Zložte armatúry a skontrolujte úplnosť!

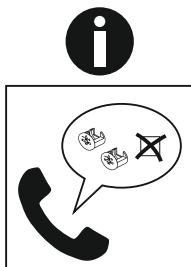

- Ⓓ Bei fehlenden Teilen kontaktieren Sie den Hersteller!
- Ⓖ If parts are missing, please turn to the manufacturer!
- Ⓕ En cas de pièces manquantes, veuillez contacter le fabricant!
- Ⓓ Contacteer de fabrikant als er onderdelen ontbreken!
- Ⓔ En el caso de que falten piezas, póngase en contacto con el fabricante!
- Ⓒ W razie braku części skontaktuj się z producentem!

- ⒲ При отсутствии каких-либо частей обратитесь к производителю!
- Ⓙ In caso di pezzi mancanti, contattare il produttore!
- Ⓔ Ha hiányozna valamelyik elem, lépjen kapcsolatba a gyártóval!
- Ⓖ Em caso de peças em falta, entre em contato com o fabricante!
- Ⓒ Pro chýbajúce diely kontaktujte výrobcu!
- Ⓒ Ak vám chýbajú diely kontaktujte výrobcu!

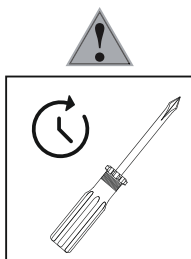

- Ⓓ Ziehen Sie die Schrauben nach einiger Zeit des Gebrauchs erneut fest!
- Ⓖ Please re-tighten the screws after having used the product for a while!
- Ⓕ Resserrer les vis après un certain temps d'utilisation!
- Ⓓ Draai de schroeven na een zekere gebruikstijd opnieuw vast!
- Ⓔ Asegure de nuevo los tornillos tras usarlo durante un tiempo!
- Ⓒ Po pewnym czasie użytkowania ponownie dokręć śruby!

- ⒲ Спустя некоторое время использования подкрутите гайки!
- Ⓙ Stringere nuovamente le viti dopo un certo periodo di utilizzo!
- Ⓔ A használat során némi idő elteltével húzza meg újra a csavarokat!
- Ⓖ Reaperte os parafusos após algum tempo de uso!
- Ⓒ Po určité době používání šrouby znovu utáhněte!
- Ⓒ Po určitej dobe používania skrutky znovu utiahnite!

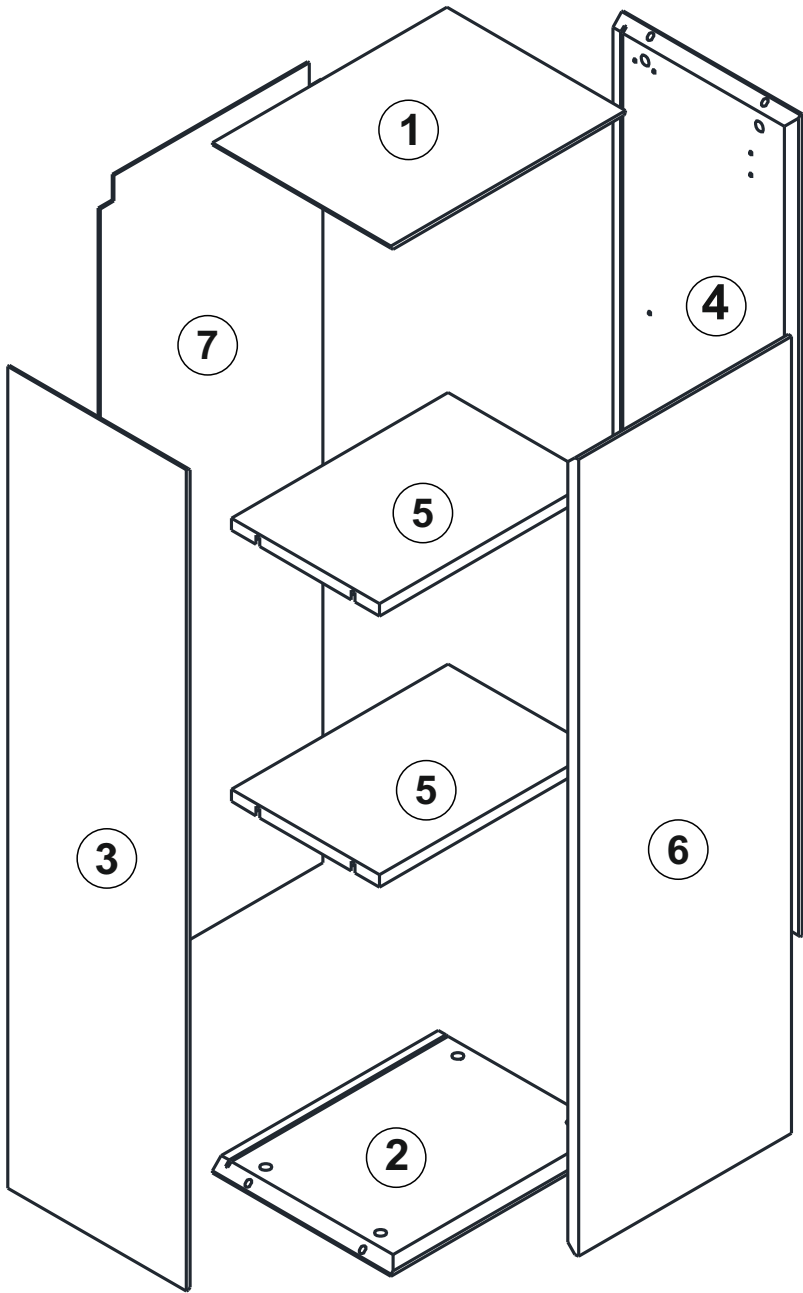
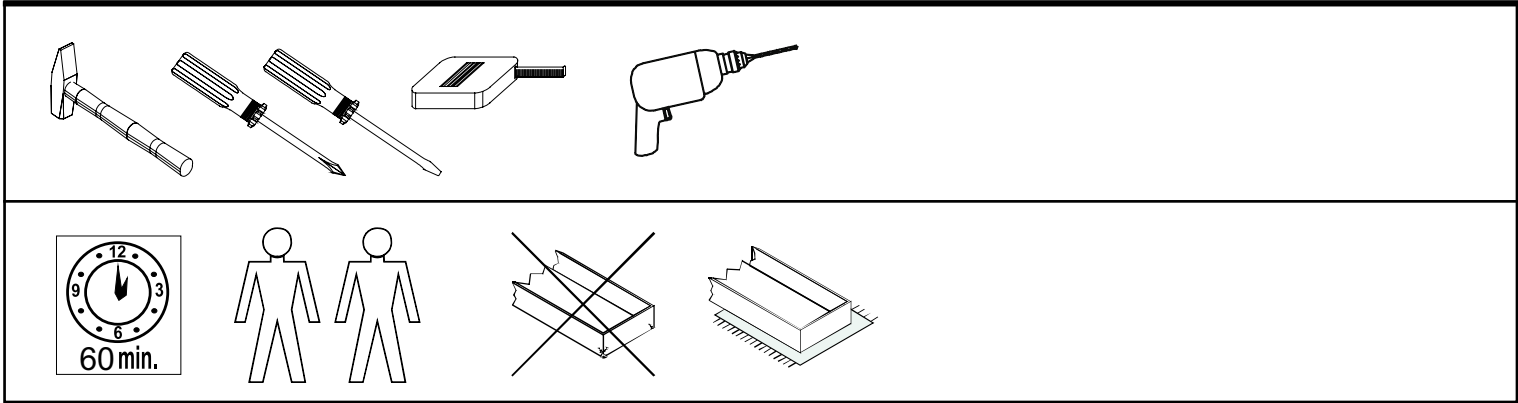

.01	1	394	300	18
.02	1	394	300	18
.03	1	1194	300	18
.04	1	1194	300	18
.05	2	364	249	18
.06	1	1158	358	18
.07	1	1174	374	3

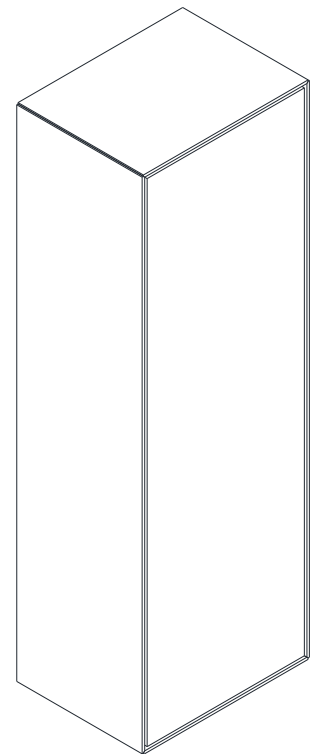

<b>BOX 1</b>	1,2,3,4,5,5,6,7
--------------	-----------------

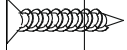

**A18x28**



**A41x16**

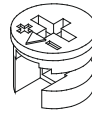

**A22x16**

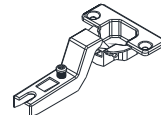

**C02x1**

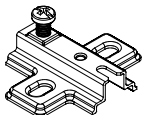

**C06x1**



**A06x16**  
18 mm

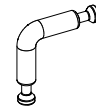

**K48x8**

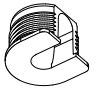

**V10x8**

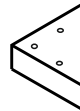

**A73x4**  
SYH

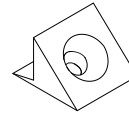

**A25x18**  
BYZ

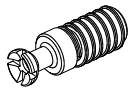

**V11x8**

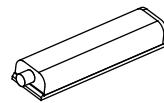

**K40x1**



**C10x1**

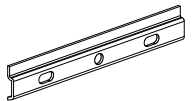

**B53x1**  
MESAN  
360 MM

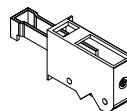

**B52x1**  
SAMET  
BYZ  
SOL

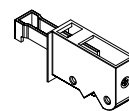

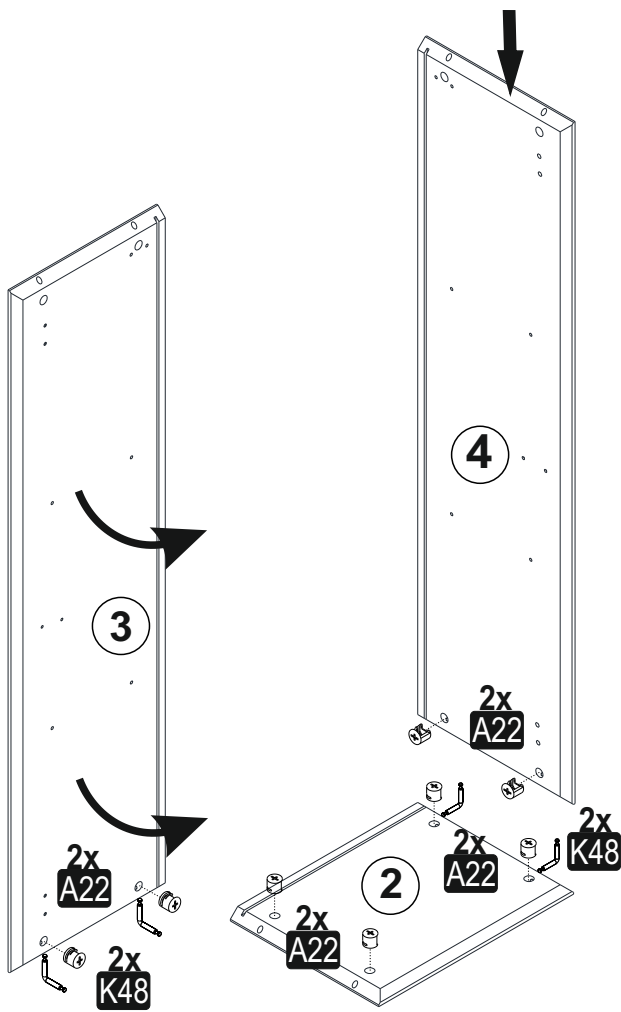

**B51x1**  
SAMET  
BYZ  
SaG

1

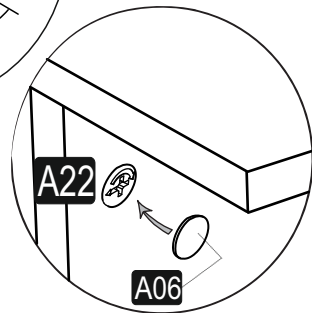
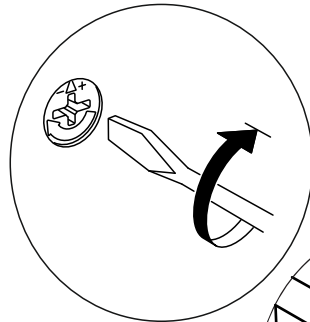
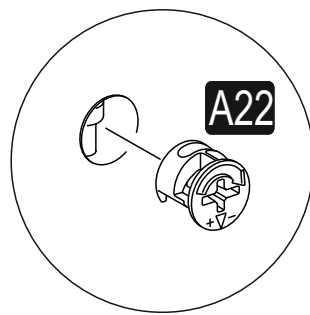

2

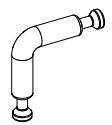

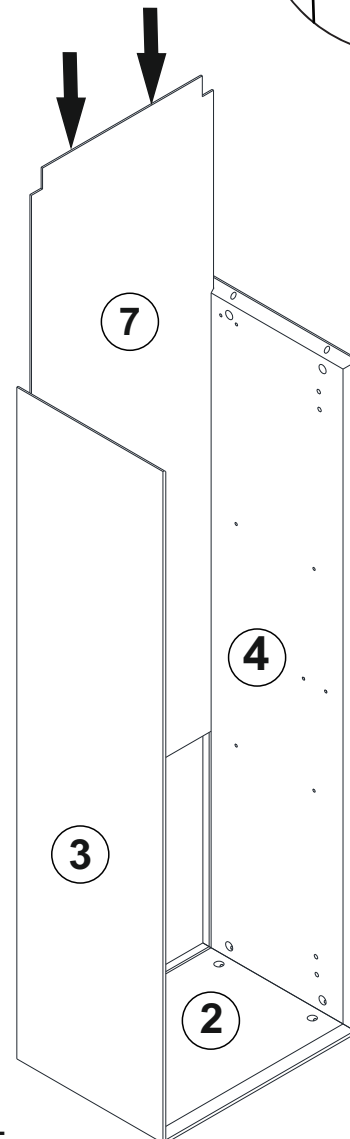

<b>K48</b>	Minifix Mil 90	
8x36		<b>4x</b>
<b>A22</b>	Minifix G18	
15x14		<b>8x</b>
<b>A06</b>	TAPA	
BYZ 18 mm		<b>8x</b>



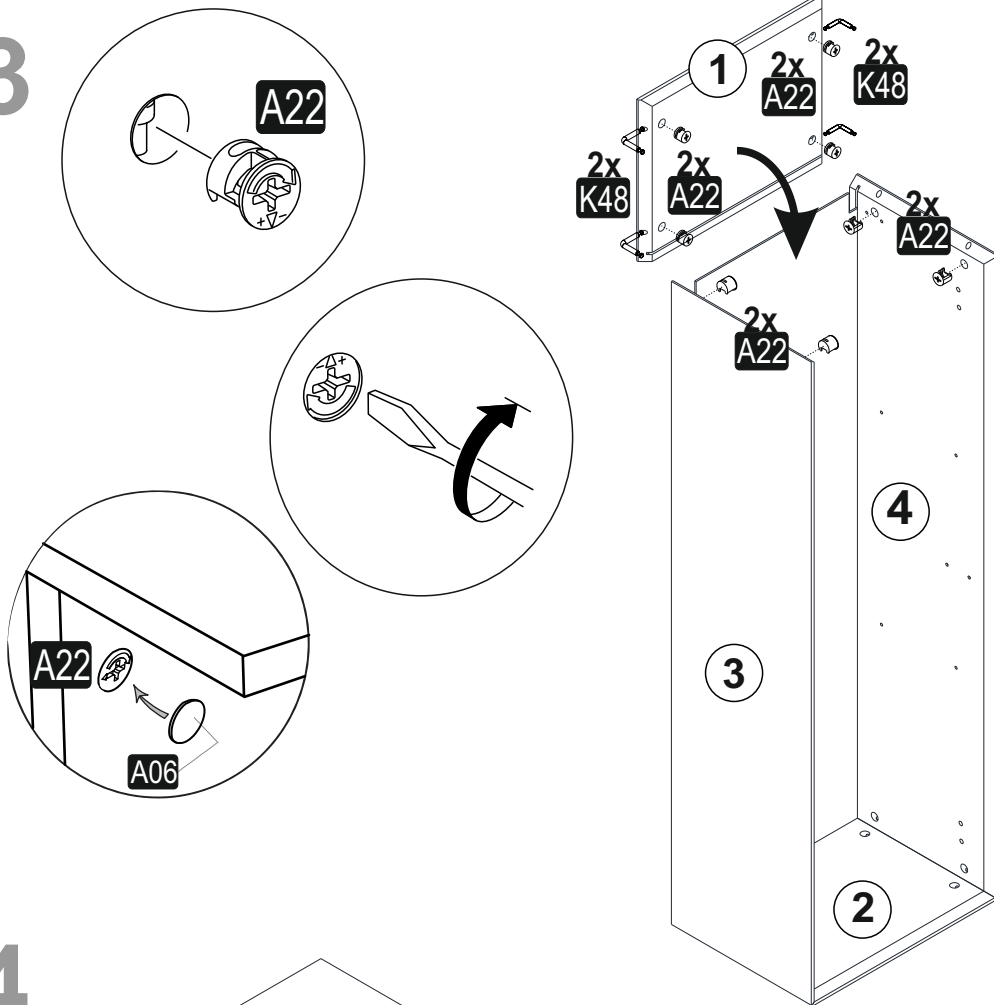

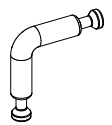
3

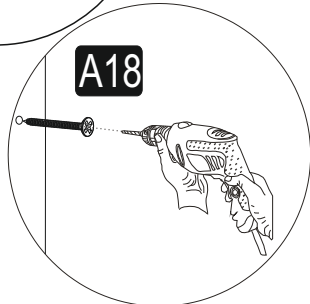
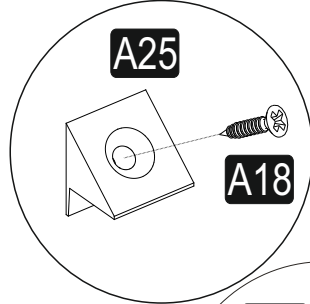
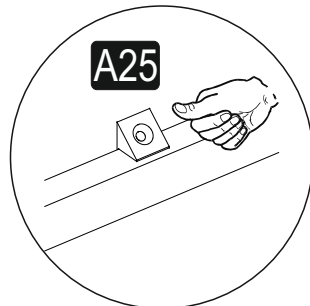
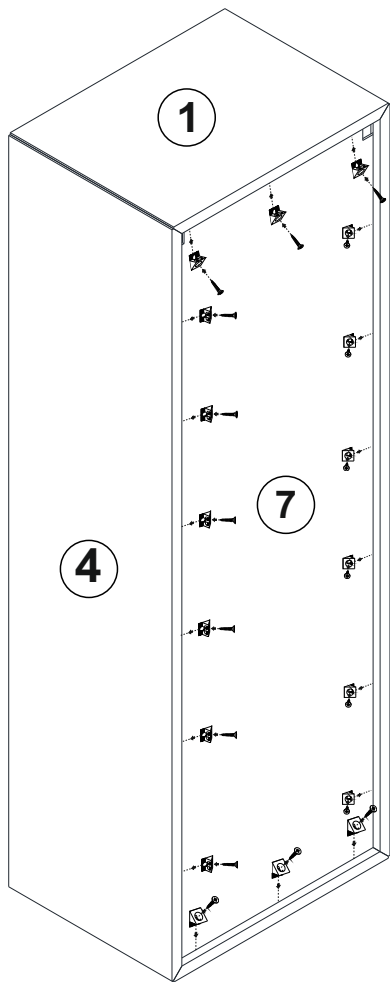

<b>K48</b>	Minifix Mil 90		<b>4x</b>
8x36			
<b>A22</b>	Minifix G18		<b>8x</b>
15x14			
<b>A06</b>	TAPA		<b>8x</b>
BYZ 18 mm			

4



<b>A25</b>	ARKLK PM		<b>18x</b>
BYZ			
<b>A18</b>	YHB VD		<b>18x</b>
3,5x18			

5

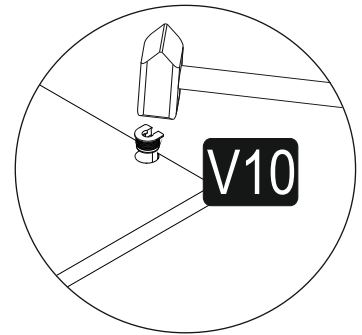
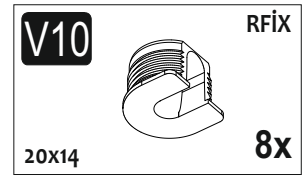
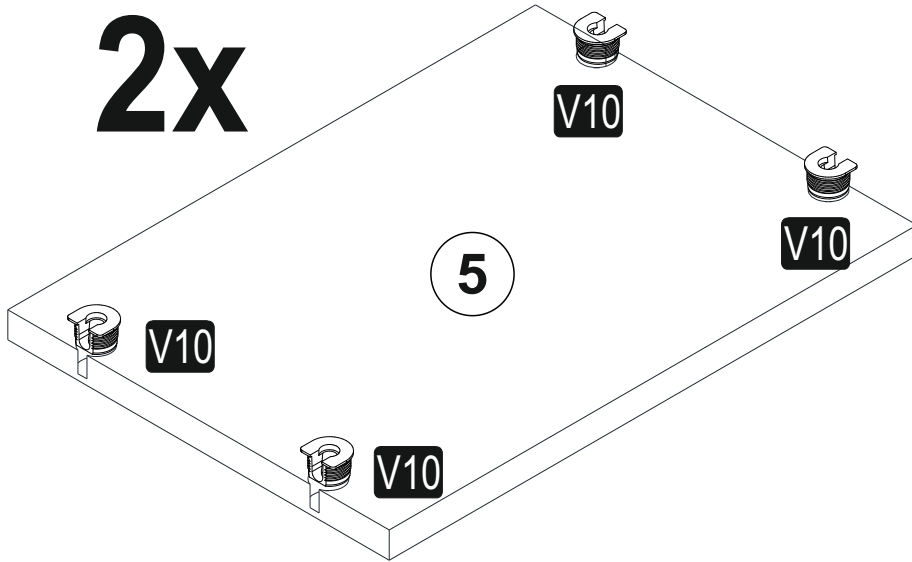

2x

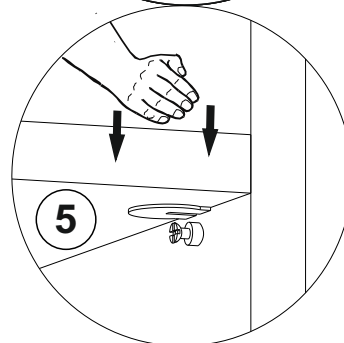
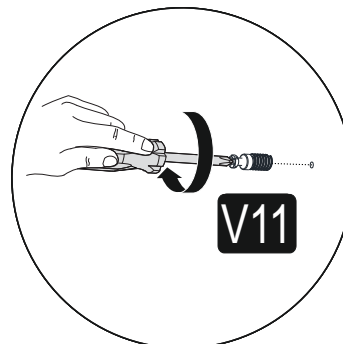
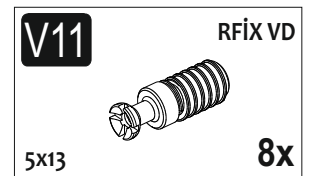
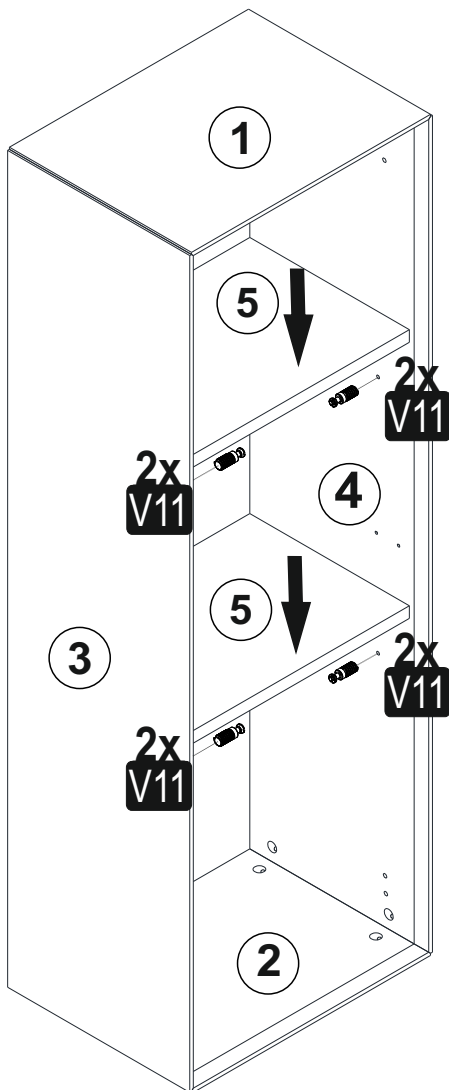

6

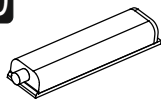

# 7 V1

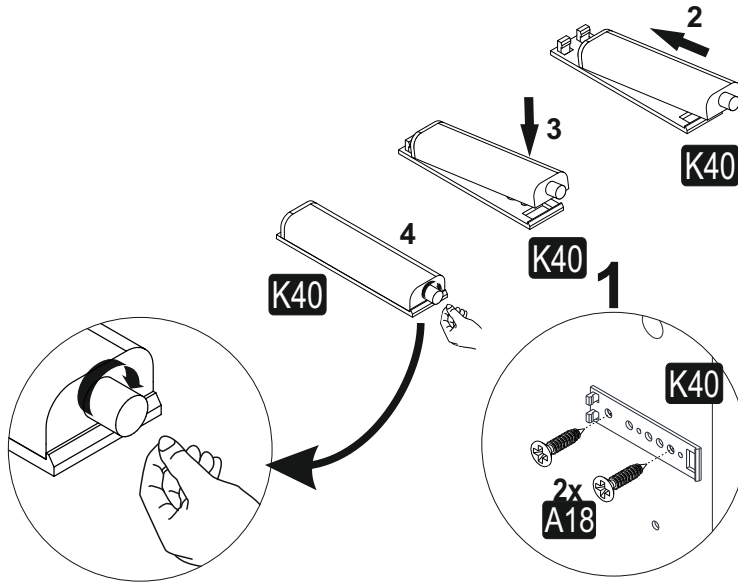
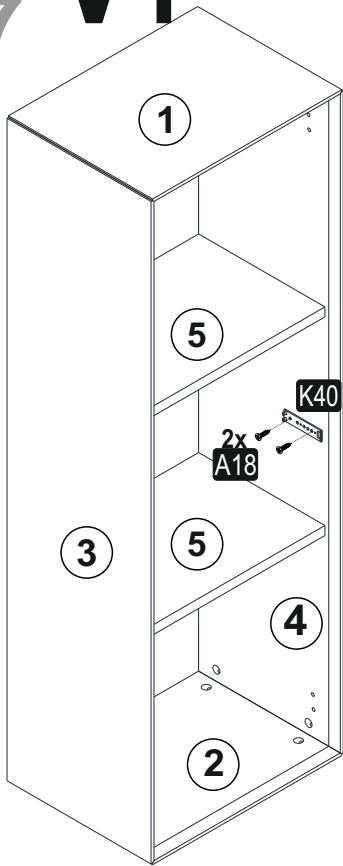

<b>K40</b>	BASAÇ	<b>A18</b>	YHB VD
STD			
	1x	3,5x18	2x

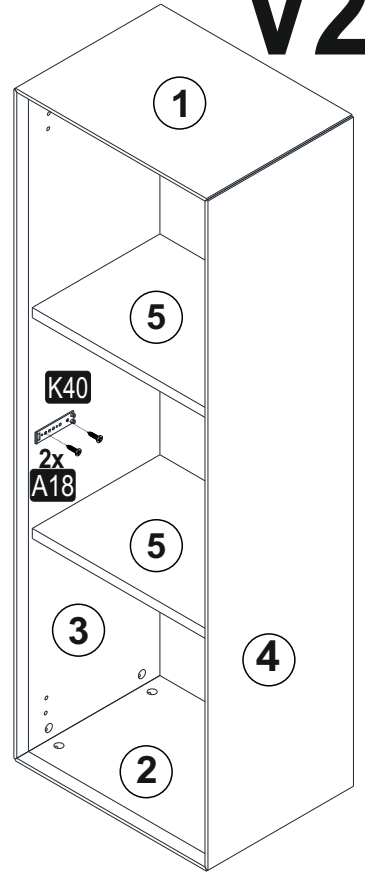

# V2



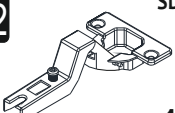
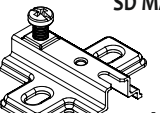
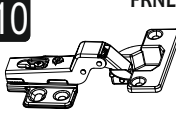

# 8

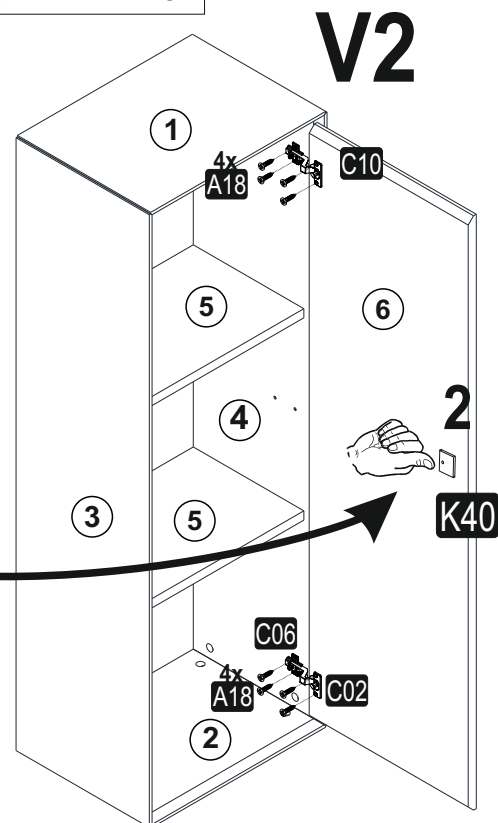
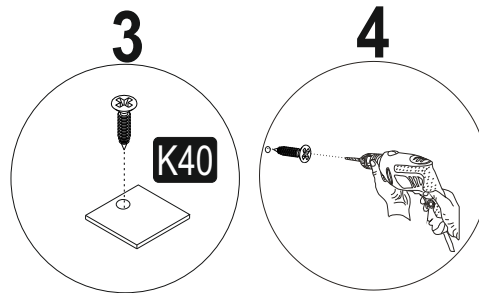
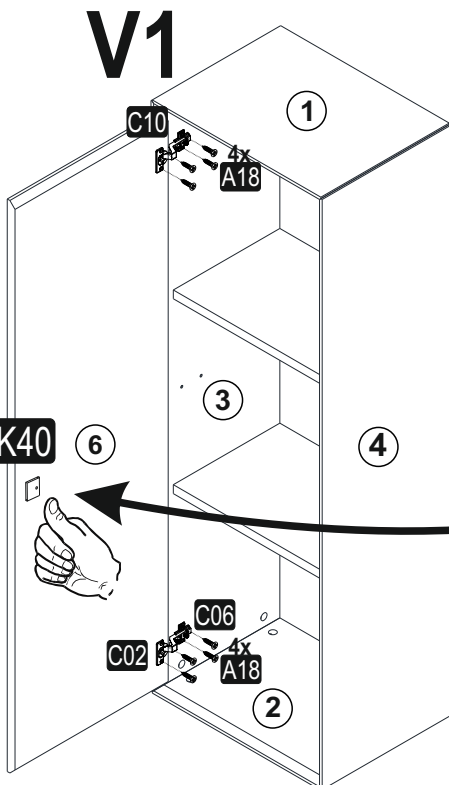
<b>C02</b>	SDM	<b>C06</b>	SD MA	<b>C10</b>	FRNL SDM	<b>A18</b>	YHB VD
							
1x		1x		1x	3,5x18	8x	

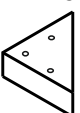

9

# V1

<b>A73</b>	UCGN AYK		<b>4x</b>
SYH 30mm			
<b>A41</b>	YHB VD		<b>12x</b>
4x30			

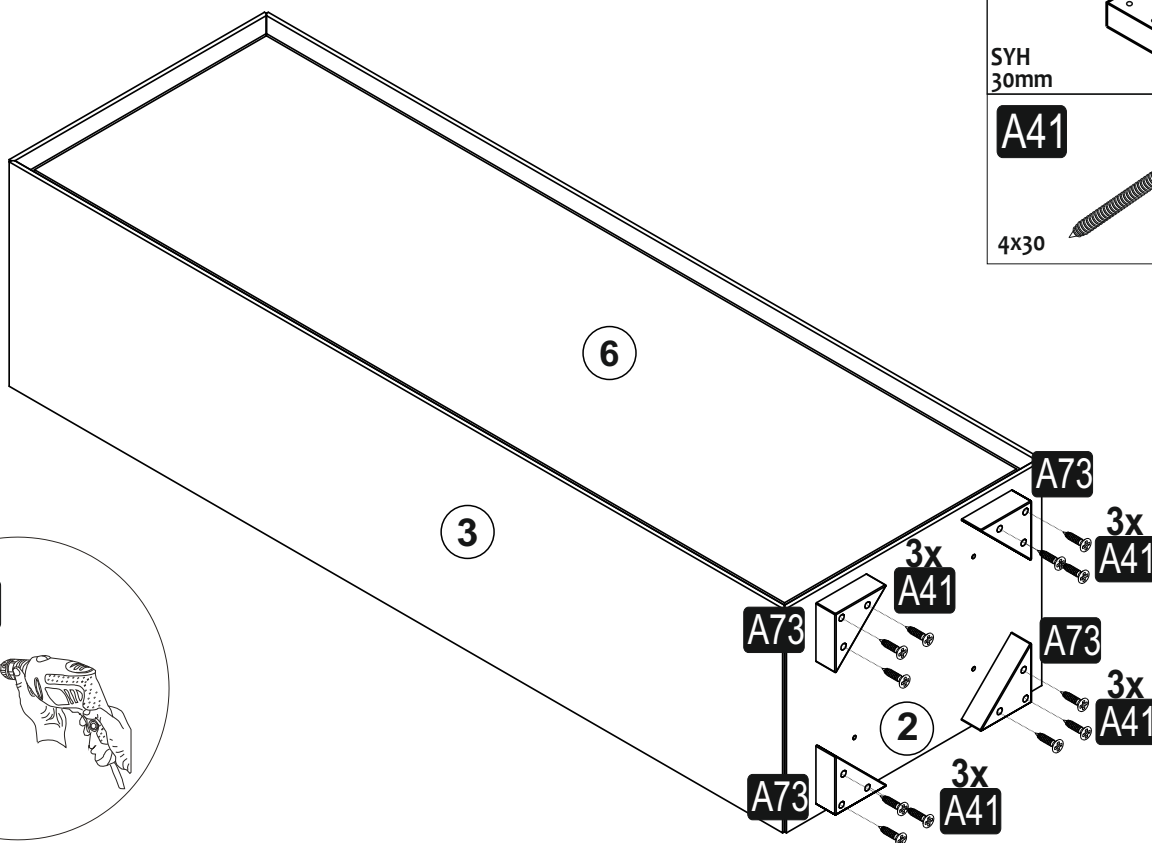

10

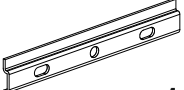
<b>B53</b>	DST ASK RY		<b>1x</b>
MESAN 360mm			

# V2

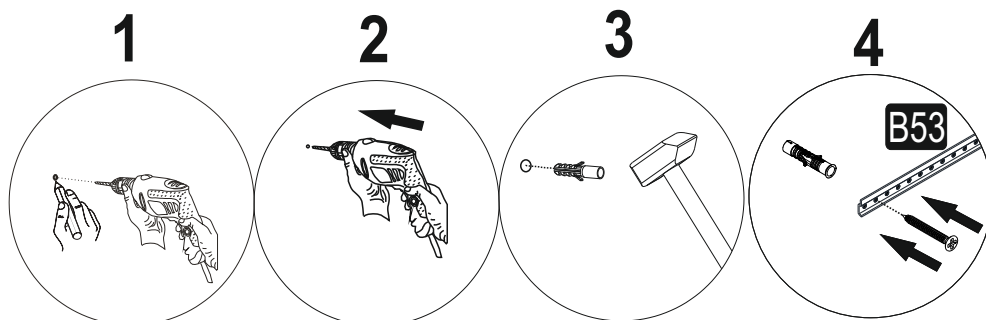
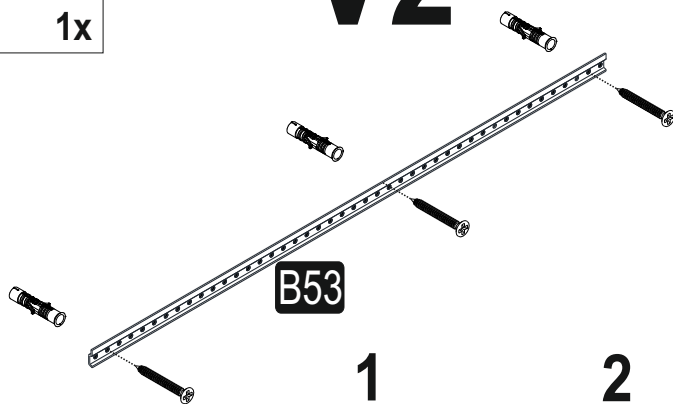

# 11

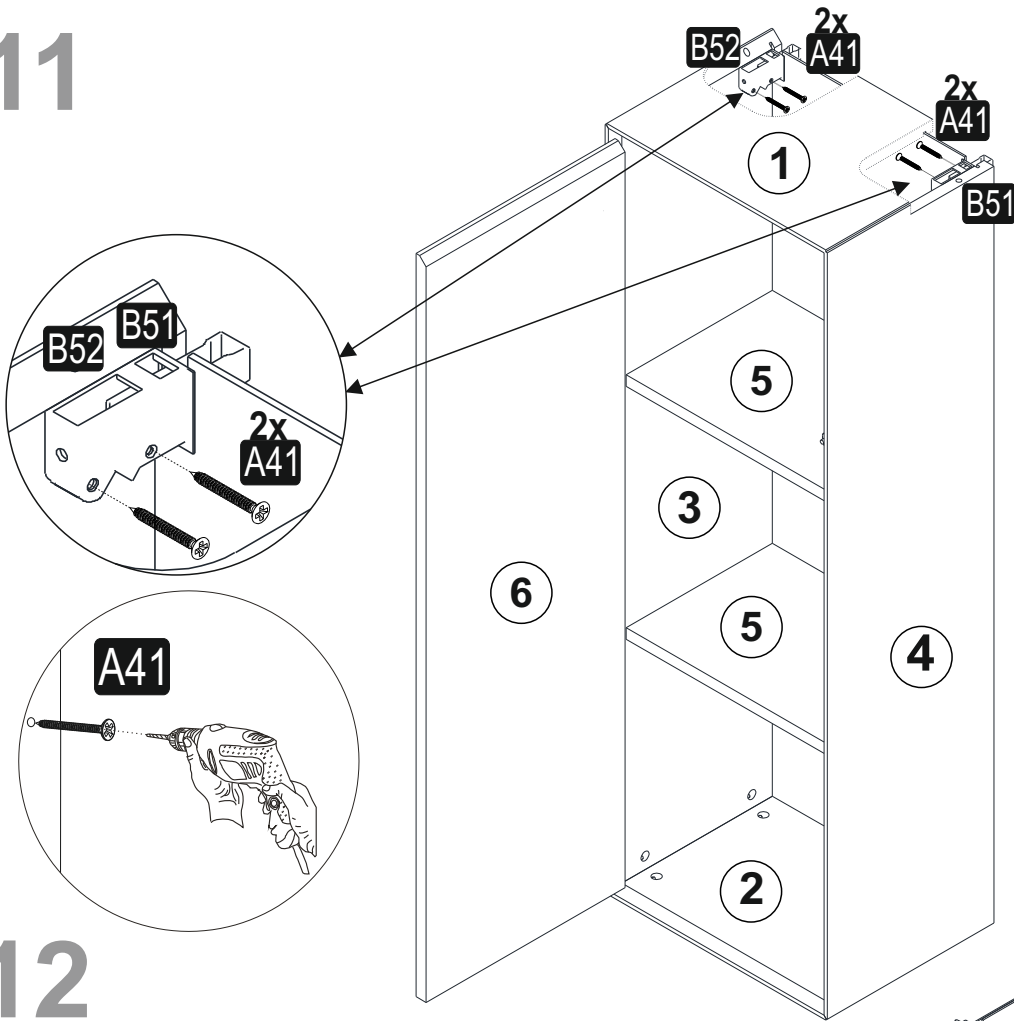

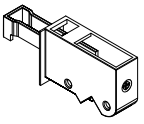
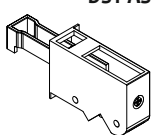
<b>A41</b>	YHB VD
	
4x30	4x
<b>B51</b>	DST ASK SaĎ
	
MESAN BYZ	1x
<b>B52</b>	DST ASK SOL
	
MESAN BYZ	1x

# 12

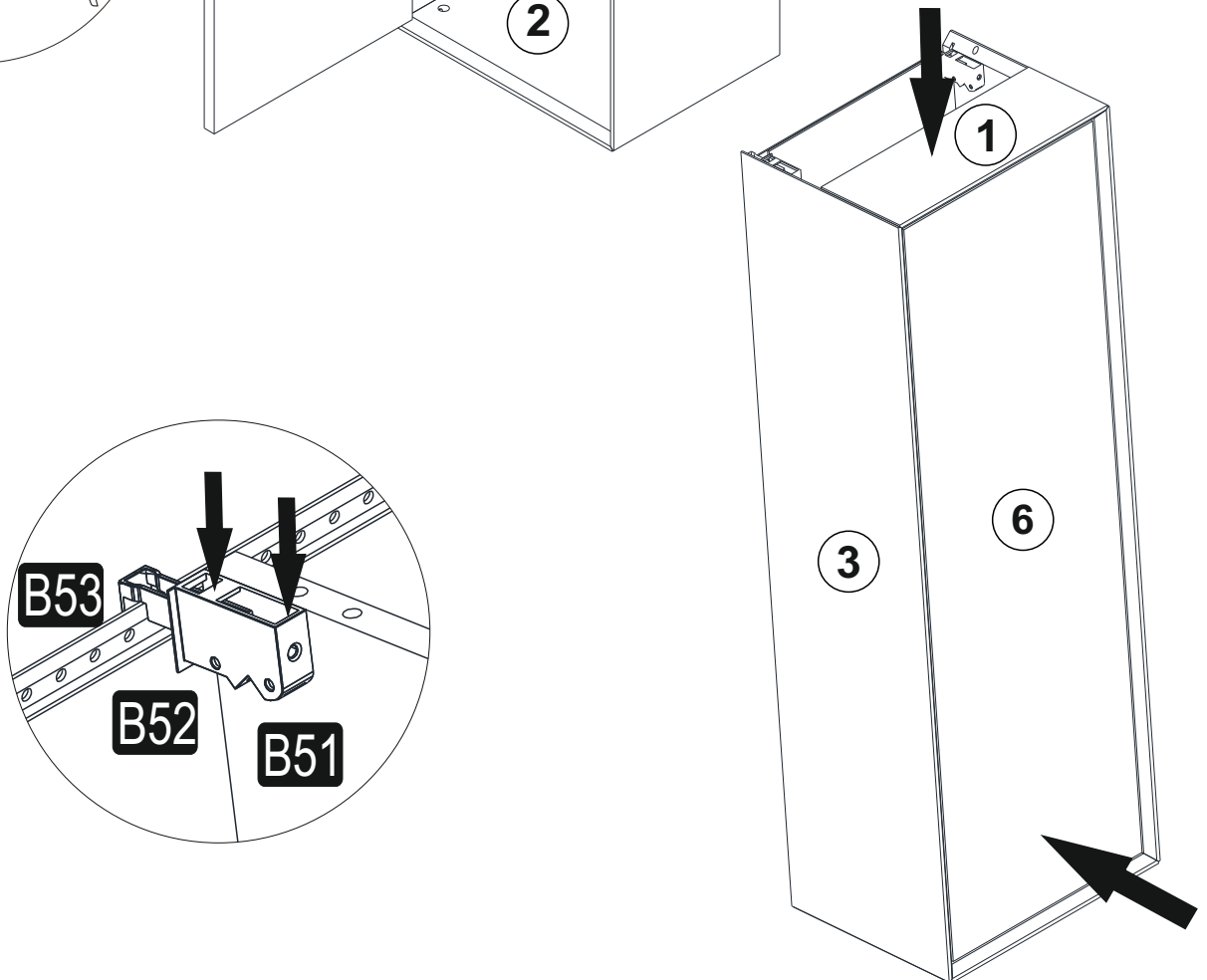

13

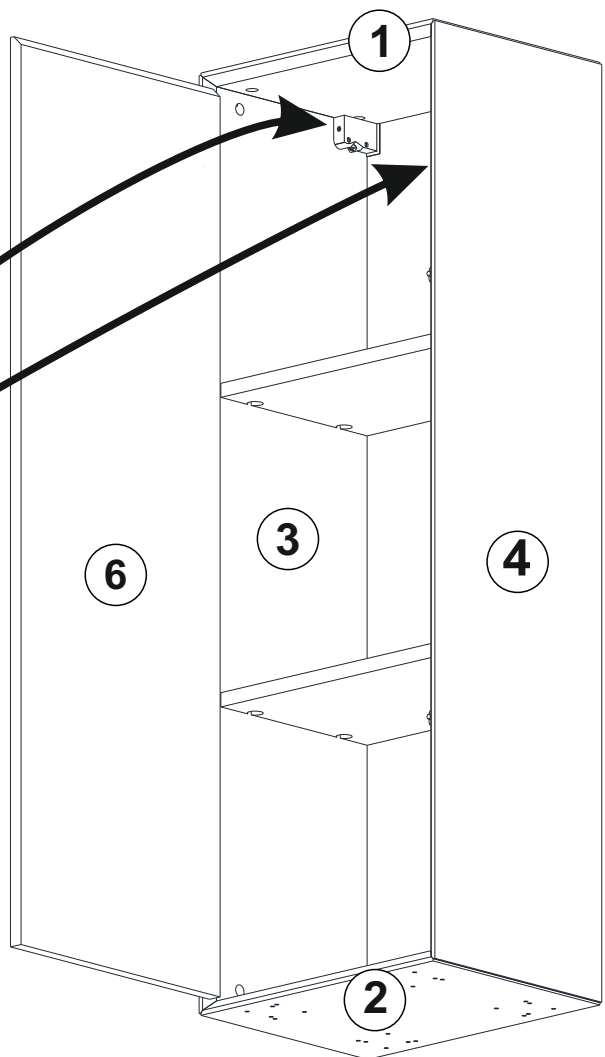
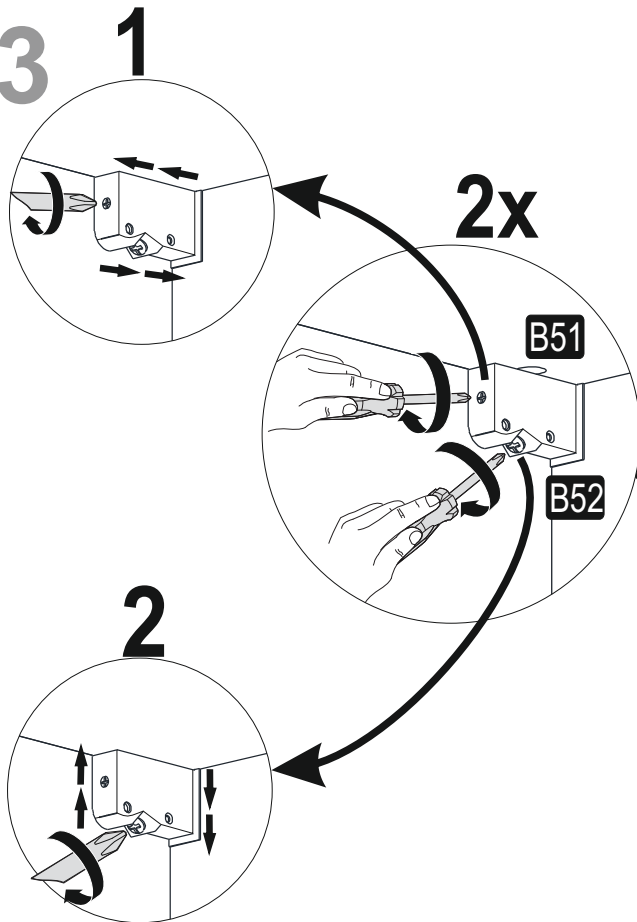

14

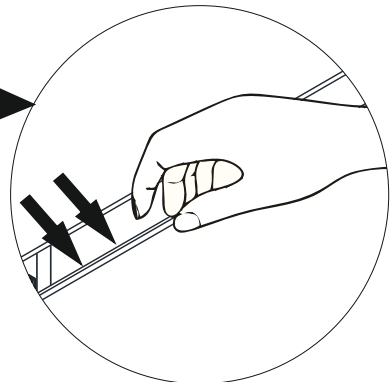
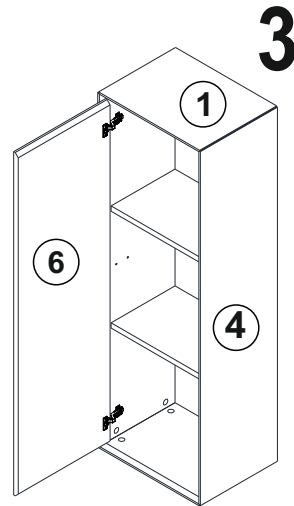
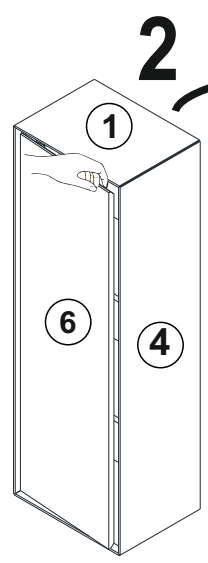
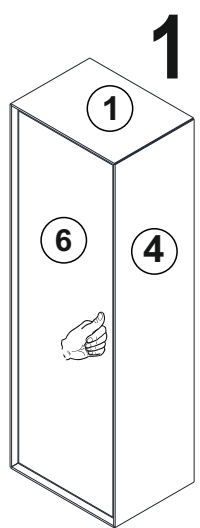



- Ⓓ Das Möbel muss an der Wand befestigt werden!
- ⒸⒷ Please ensure to mount the furniture to the wall!
- ⒻⒼ Les meubles doivent être fixés au mur!
- ⒶⒺ Het meubel moet aan de wand worden vastgemaakt!
- ⒺⒶ El mueble se tiene que fijar a la pared!
- ⒶⒺ Mebel należy przymocować do ściany!



- Ⓓ Informieren Sie sich vor der Wandmontage über das geeignete Montagematerial!
- ⒸⒷ Please get informed on suitable assembly materials before commencing the wall-mounting!
- ⒻⒼ Renseignez-vous sur le matériel de montage approprié avant le montage mural!
- ⒶⒺ Informeer u voor de wandmontage over het geschikte montagemateriaal!
- ⒺⒶ Infórmese antes del montaje en la pared del material apropiado de montaje!
- ⒶⒺ Przed montażem na ścianie upewnij się, jaki jest potrzebny właściwy materiał montażowy!



- Ⓓ Beschaffen Sie sich das angemessene Material zur Wandbefestigung!
- ⒸⒷ Please obtain suitable wall-mounting materials!
- ⒻⒼ Procurez-vous le matériel approprié pour le montage mural!
- ⒶⒺ Verschaf u het adequate materiaal voor de wandbevestiging!
- ⒺⒶ Procúrese el material adecuado para la fijación a la pared!
- ⒶⒺ Zakup odpowiedni materiał do przymocowania na ścianie!



- Ⓓ Lassen Sie die Wandbefestigung von einer fachkundigen Person vornehmen!
- ⒸⒷ Ensure all wall-mounting is carried out by competent personnel!
- ⒻⒼ Faites effectuer le montage mural par une personne compétente!
- ⒶⒺ Laat de wandbevestiging door een professional uitvoeren!
- ⒺⒶ Deje que la fijación a la pared la haga un profesional!
- ⒶⒺ Zleć przymocowanie do ściany odpowiednio doświadczonej osobie!

- ⒶⒺ Мебель должна крепиться к стене!
- ⒶⒺ Il mobile deve essere fissato alla parete!
- ⒶⒺ A bútor a falon rögzítendő!
- ⒶⒺ O móvel tem que ser fixado na parede!
- ⒶⒺ Nábytek musí být připevněn ke stěně!
- ⒶⒺ Montáž na stenu zverte kvalifikovanej osobe!

- ⒶⒺ Перед тем, как крепить мебель к стене, получите информацию о подходящем крепежном материале!
- ⒶⒺ Prima del fissaggio alla parete, informarsi sul materiale di montaggio adatto!
- ⒶⒺ A falra szerelés előtt tájékozódjon, hogy ehhez milyen szerelőanyagok szükségesek!
- ⒶⒺ Antes da montagem na parede, informe-se sobre o material de montagem adequado!
- ⒶⒺ Informujte se o vhodném montážním materiálu před montáží na stěnu!
- ⒶⒺ Pred montážou na stenu sa informujte o vhodnom montážnom materiáli!

- ⒶⒺ Приобретите соответствующий материал для крепления к стене!
- ⒶⒺ Procurarsi il materiale opportuno per il fissaggio alla parete!
- ⒶⒺ Szerezze be a falra szereléshez szükséges, megfelelő anyagokat!
- ⒶⒺ Obtenha o material adequado para a montagem na parede!
- ⒶⒺ Opatíte si vhodný materiál pro montáž na stěnu!
- ⒶⒺ Zabezpečte si vhodný materiál na montáž na stenu!

- ⒶⒺ Поручите выполнение работ по креплению к стене специалисту!
- ⒶⒺ Far effettuare il fissaggio alla parete ad un esperto!
- ⒶⒺ A bútor falra rögzítését végeztesse ehhez értő személlyel!
- ⒶⒺ A montagem na parede deve ser executada por uma pessoa competente!
- ⒶⒺ Montáž na stěnu nechť provést odborně způsobilou osobou!
- ⒶⒺ Montáž na stenu zverte kvalifikovanej osobe!

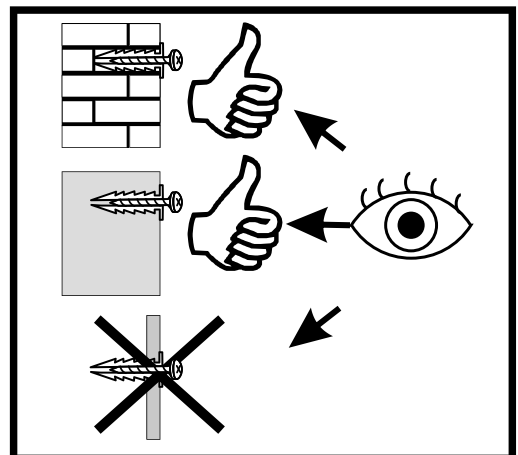

<https://quefairedemesdechets.fr>