

ATOKO

1

Aby se předešlo poškrábání nebo poškození, položte desku stolu na bílou pěnovou podložku při montáži. Vyhněte se narážení do rohů nebo hran.

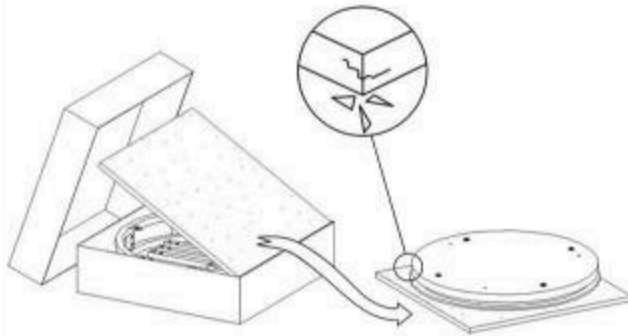

Aby ste predišli poškrábaniu alebo poškodeniu, položte dosku stola na bielu penovú podložku pri montáži. Vyhnite sa nárazom do rohov alebo hrán.

2

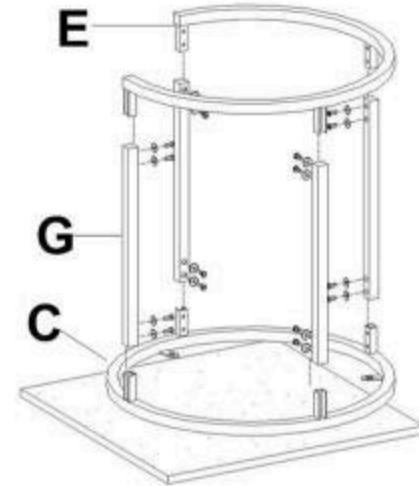
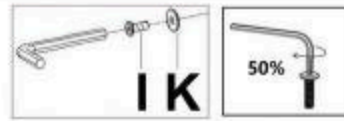

3

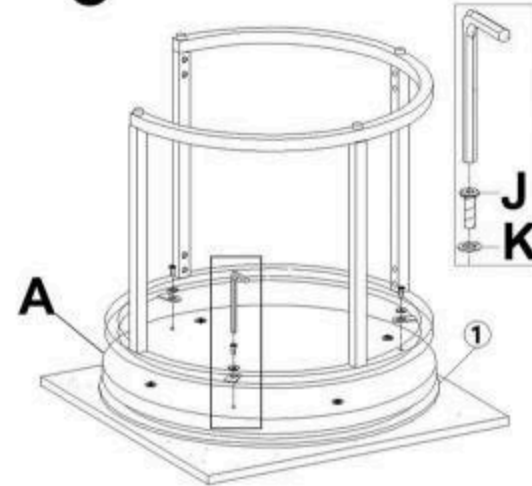

2

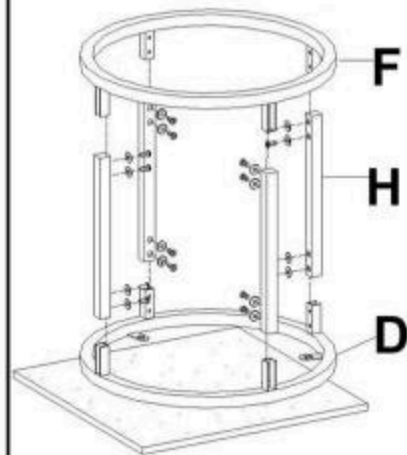
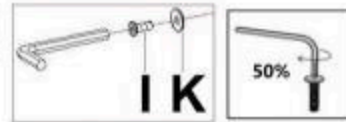

3

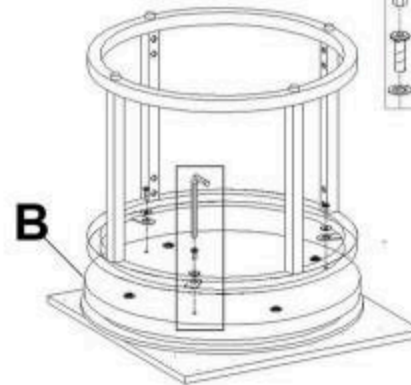
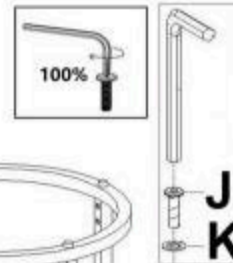

A		1
B		1
C		1
D		1
E		1
F		1
G		4
H		4
I		32
J		6
K		38

max. 15 kg



v.1