

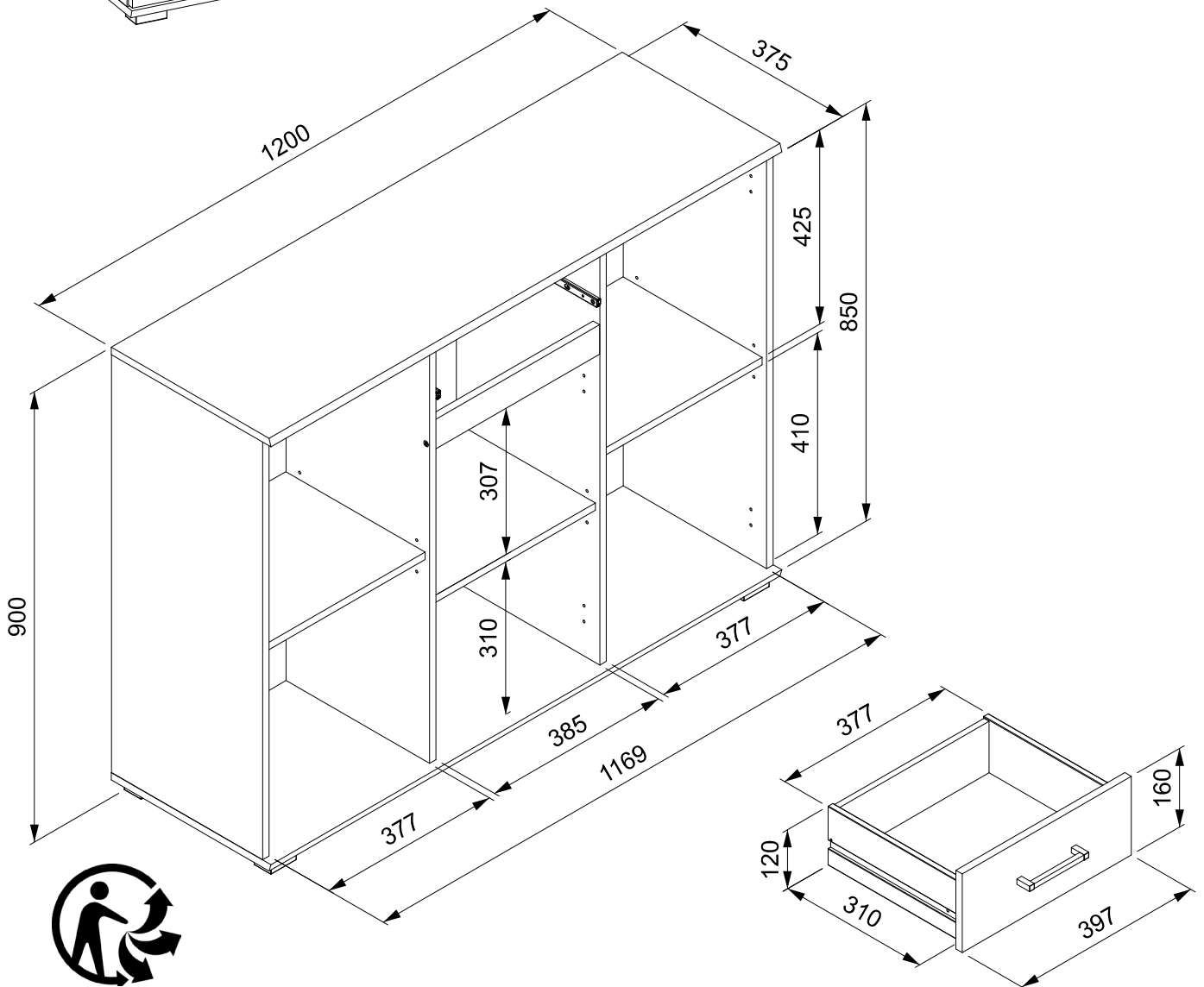

VLS01B/137

finori GmbH
Straßacker 2
D - 96253 Untersiemau

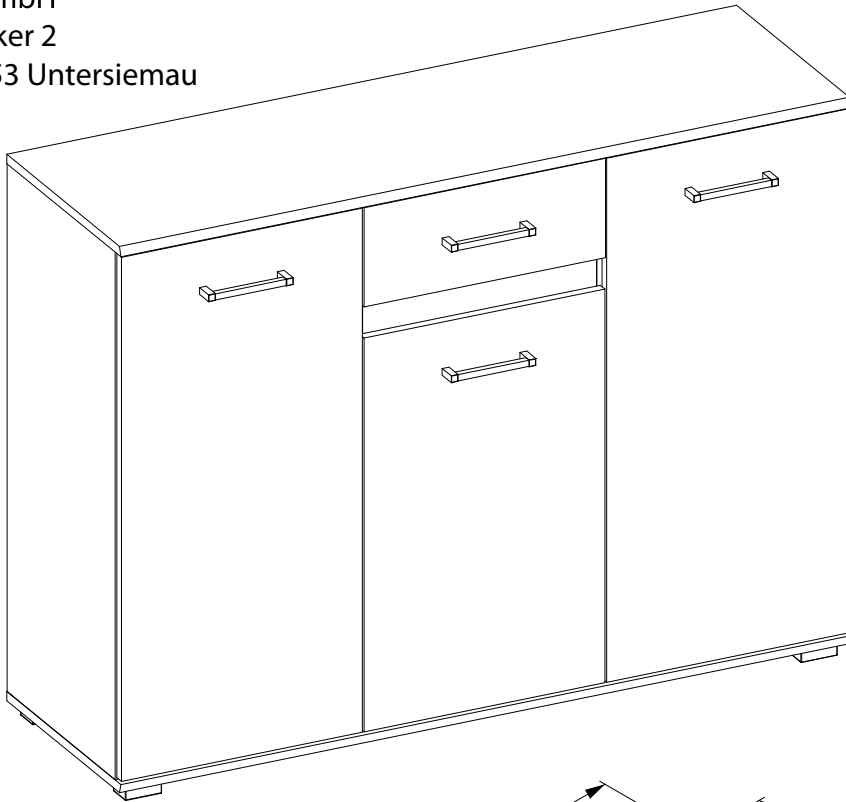



- ⓓ Befolgen Sie stets die Anleitung des Herstellers!
- ⒸⒷ Please generally follow the manufacturer's instructions!
- ⒻⓇ Suivez toujours les instructions du fabricant!
- ⓃⓁ Volg steeds de handleiding van de producent!
- ⒺⓈ Siga siempre las instrucciones del fabricante!
- ⓇⓁ Stale przestrzegaj instrukcji producenta!

- ⓇⓁ Всегда следуйте инструкции производителя!
- ⓇⓇ Seguire sempre le istruzioni del produttore!
- ⓇⓇ Mindig tartsa be a gyártó utasításait!
- Ⓡ Siga sempre as instruções do fabricante!
- ⒸⓏ Vždy dodržujte pokyny výrobce!



- ⓓ Verwenden Sie zur Reinigung nur ein feuchtes Tuch!
- ⒸⒷ Please only clean with a damp cloth!
- ⒻⓇ N'utilisez qu'un chiffon humide pour le nettoyage!
- ⓃⓁ Gebruik voor de reiniging enkel een vochtige doek!
- ⒺⓈ Para limpiar utilice sólo un paño húmedo!
- ⓇⓁ Do czyszczenia używaj wilgotnej szmatki!

- ⓇⓁ Для очистки используйте только влажную ткань!
- ⓇⓇ Per la pulizia, utilizzare solo un panno umido!
- ⓇⓇ A tisztításhoz elegendő egy nedves kendő használat!
- Ⓡ Para a limpeza use apenas um pano húmido!
- ⒸⓏ Pro čištění používejte pouze vlhký hadřík!

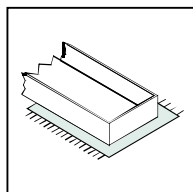

- ⓓ Bauen Sie das Produkt auf einer Unterlage auf!
- ⒸⒷ Please mount the product on a bottom support!
- ⒻⓇ Montez le produit sur une base!
- ⓃⓁ Monteer het product op een basis!
- ⒺⓈ Monte el producto sobre una base!
- ⓇⓁ Rozkładaj produkt na podkładce!

- ⓇⓁ Собирайте изделие на подстилке!
- ⓇⓇ Montare il prodotto su un supporto!
- ⓇⓇ Az összeszereléskor helyezzen a termék alá megfelelő alátétet!
- Ⓡ Monte o produto numa superfície plana!
- ⒸⓏ Výrobek smontujte na pevném podkladu!

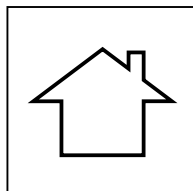

- ⓓ Verwenden Sie das Produkt nur in Innenräumen!
- ⒸⒷ Please exclusively use the product indoors!
- ⒻⓇ N'utilisez le produit qu'à l'intérieur!
- ⓃⓁ Gebruik het product enkel binnenshuis!
- ⒺⓈ Utilice el producto sólo en interiores!
- ⓇⓁ Używaj produkt tylko w pomieszczeniach wewnętrznych!

- ⓇⓁ Используйте изделие только во внутренних помещениях!
- ⓇⓇ Utilizzare il prodotto solo in ambienti interni!
- ⓇⓇ A termék csak bel terekben használható!
- Ⓡ Use o produto apenas no interior!
- ⒸⓏ Používejte výrobek pouze uvnitř!

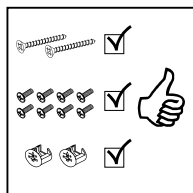

- ⓓ Legen Sie die Beschläge zusammen und prüfen Sie die Vollständigkeit!
- ⒸⒷ Please join the fittings and verify their completeness!
- ⒻⓇ Pliez les raccords ensemble et vérifiez qu'ils sont complets!
- ⓃⓁ Leg de onderdelen samen en controleer de volledigheid!
- ⒺⓈ Junte los accesorios y compruebe que están todos!
- ⓇⓁ Rozlož poszczególne części i sprawdź kompletność!

- ⓇⓁ Положите фурнитуру в одно место и проверьте комплектность!
- ⓇⓇ Mettere insieme le guarnizioni e verificarne la completezza!
- ⓇⓇ Állítsa össze a sarokvasakat, és ellenőrizze, hogy épek-e!
- Ⓡ Coloque os encaixes juntos e verifique se estão completos!
- ⒸⓏ Složte armatury a zkontrolujte úplnost!

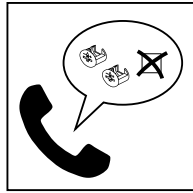

- ⓓ Bei fehlenden Teilen kontaktieren Sie den Hersteller!
- ⒸⒷ If parts are missing, please turn to the manufacturer!
- ⒻⓇ En cas de pièces manquantes, veuillez contacter le fabricant!
- ⓃⓁ Contacteer de fabrikant als er onderdelen ontbreken!
- ⒺⓈ En el caso de que falten piezas, póngase en contacto con el fabricante!
- ⓇⓁ W razie braku części skontaktuj się z producentem!

- ⓇⓁ При отсутствии каких-либо частей обратитесь к производителю!
- ⓇⓇ In caso di pezzi mancanti, contattare il produttore!
- ⓇⓇ Ha hiányozna valamelyik elem, lépjen kapcsolatba a gyártóval!
- Ⓡ Em caso de peças em falta, entre em contato com o fabricante!
- ⒸⓏ Pro chybějící díly kontaktujte výrobce!

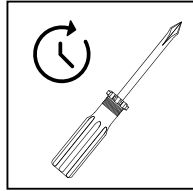

- ⓓ Ziehen Sie die Schrauben nach einiger Zeit des Gebrauchs erneut fest!
- ⒸⒷ Please re-tighten the screws after having used the product for a while!
- ⒻⓇ Resserrer les vis après un certain temps d'utilisation!
- ⓃⓁ Draai de schroeven na een zekere gebruikstijd opnieuw vast!
- ⒺⓈ Asegure de nuevo los tornillos tras usarlo durante un tiempo!
- ⓇⓁ Po pewnym czasie użytkowania ponownie dokręć śruby!

- ⓇⓁ Спустя некоторое время использования подкрутите гайки!
- ⓇⓇ Stringere nuovamente le viti dopo un certo periodo di utilizzo!
- ⓇⓇ A használat során némi idő elteltével húzza meg újra a csavarokat!
- Ⓡ Reaperte os parafusos após algum tempo de uso!
- ⒸⓏ Po určité době používání šrouby znovu utáhněte!



VLS01B/137

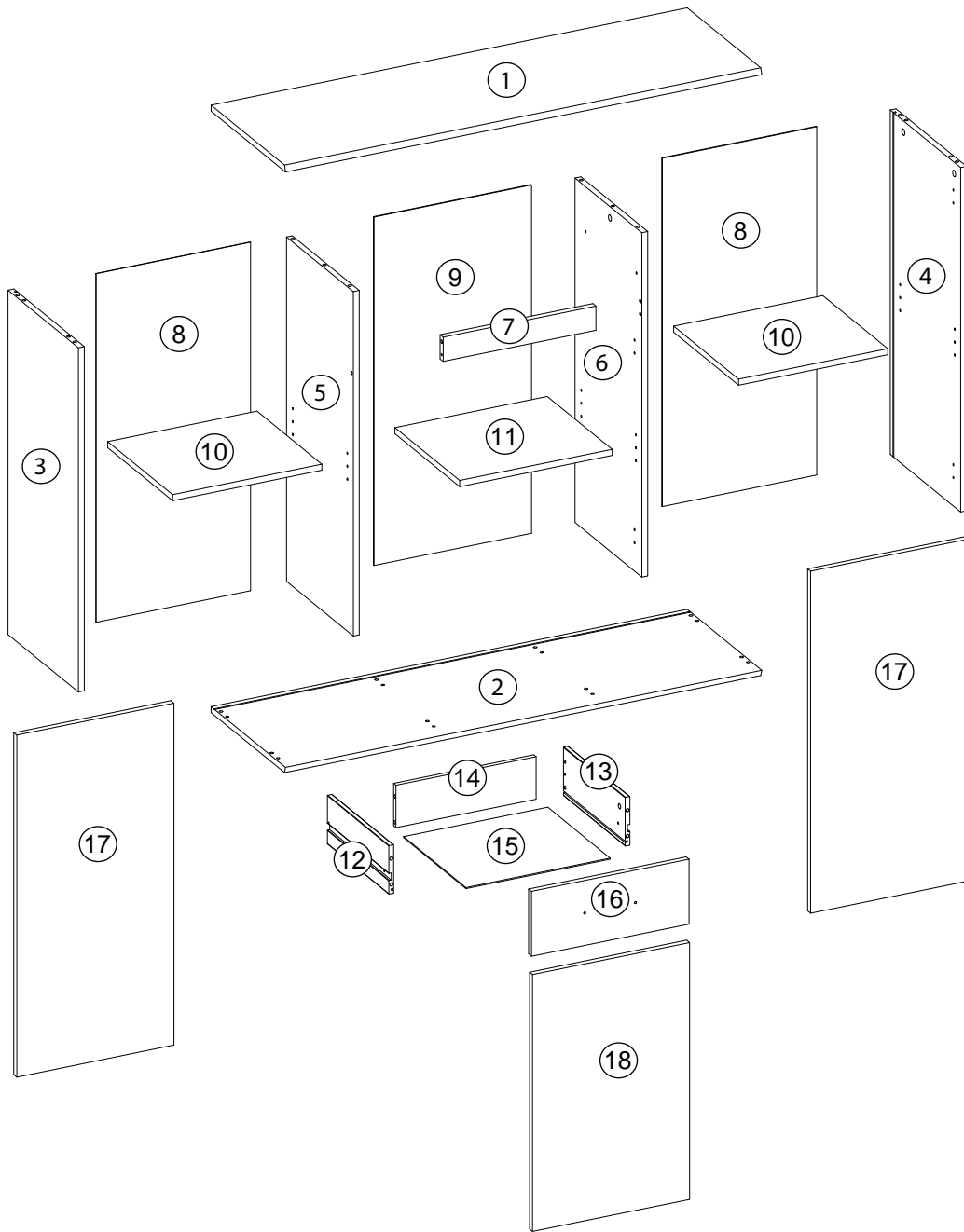
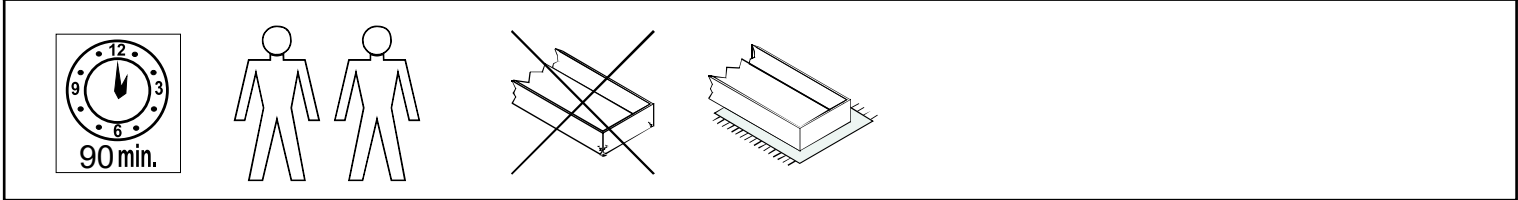
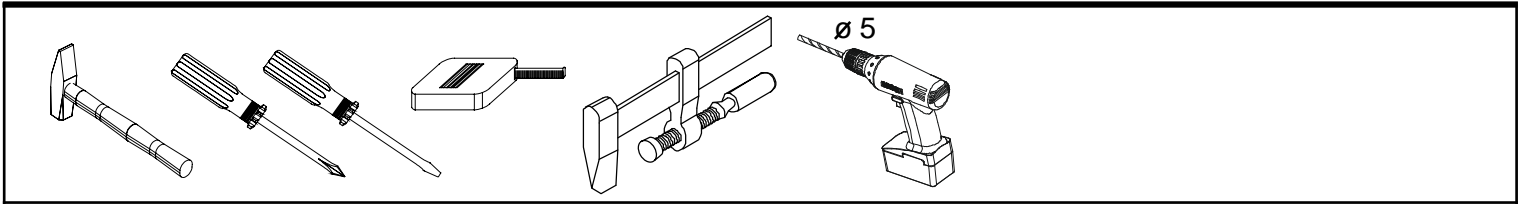

Dimensions / Abmessung in mm/		
①	1 x	1200 x 375 x 15
②	1 x	1200 x 375 x 15
③	1 x	850 x 355 x 15
④	1 x	850 x 355 x 15
⑤	1 x	850 x 337 x 15
⑥	1 x	850 x 337 x 15
⑦	1 x	385 x 60 x 15
⑧	2 x	860 x 389 x 2,5
⑨	1 x	860 x 397 x 2,5
⑩	2 x	376 x 327 x 15
⑪	1 x	384 x 327 x 15
⑫	1 x	310 x 120 x 12
⑬	1 x	310 x 120 x 12
⑭	1 x	353 x 105 x 12
⑮	1 x	363 x 314 x 2,5
⑯	1 x	396 x 160 x 15
⑰	2 x	844 x 396 x 15
⑱	1 x	634 x 396 x 15

BOX 1	1, 2, 3, 4, 5, 6, 7, 8, 9, 10, 11, 12, 13, 14, 15, 16, 17, 18
--------------	---



BOX 1

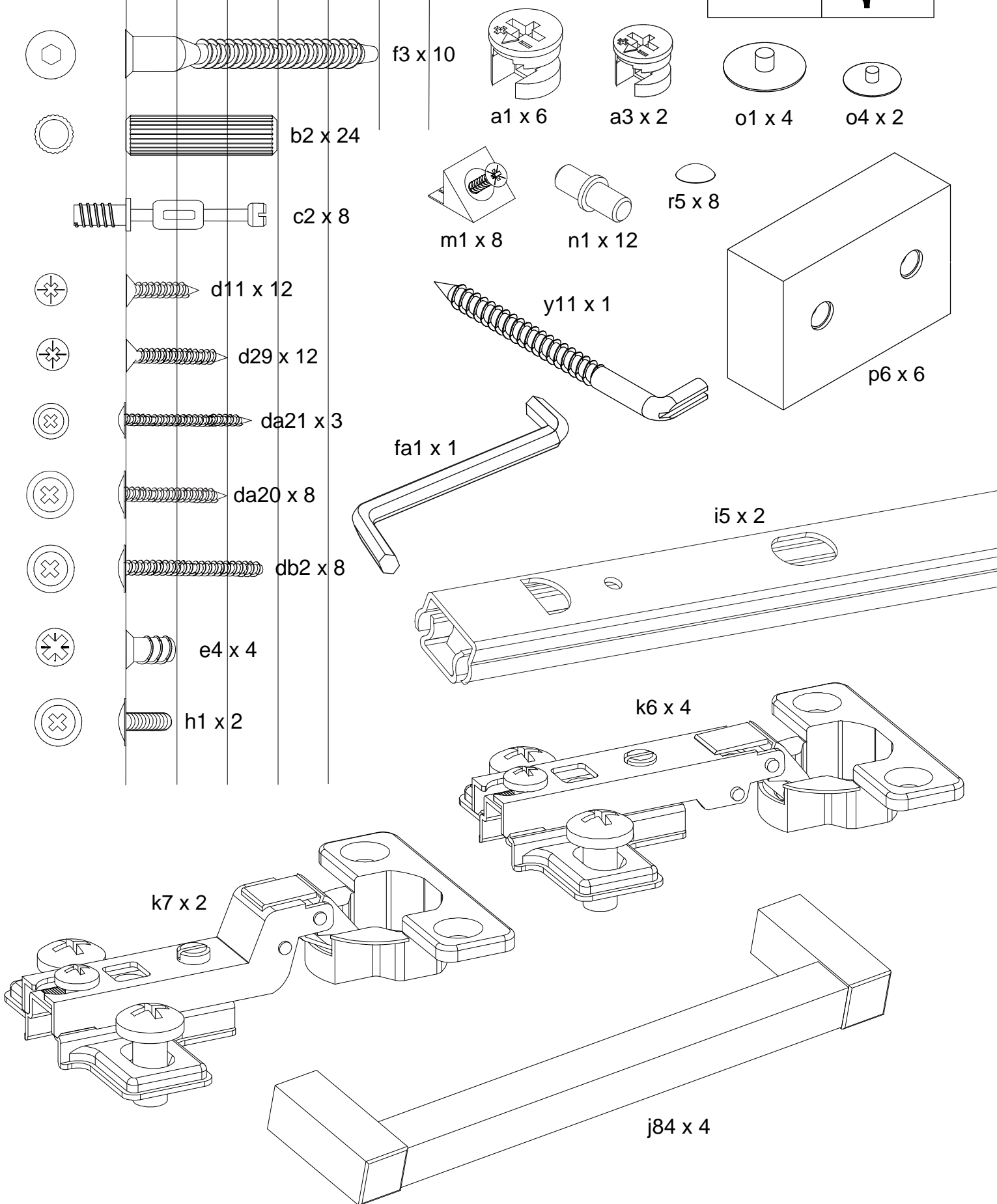

A

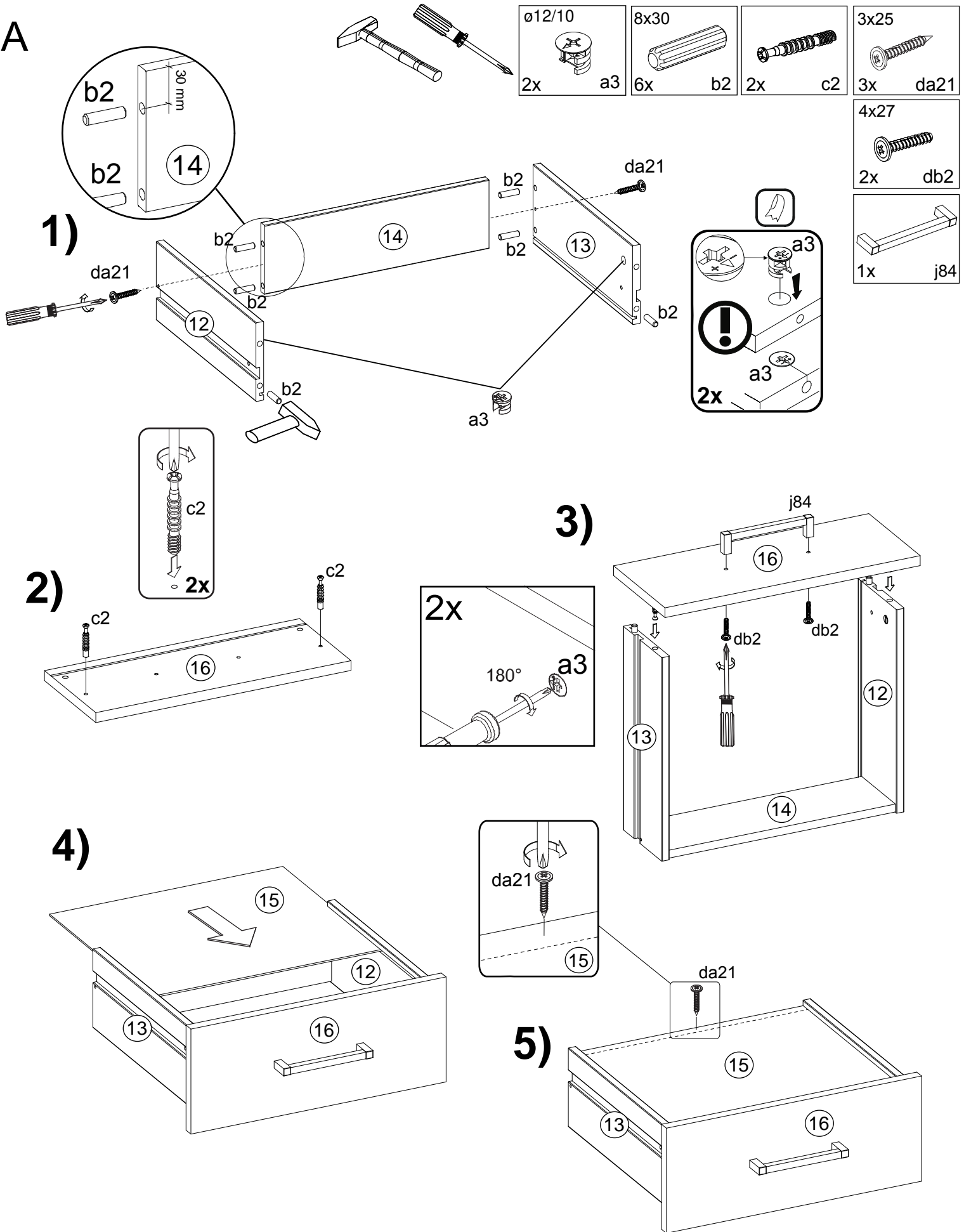

B

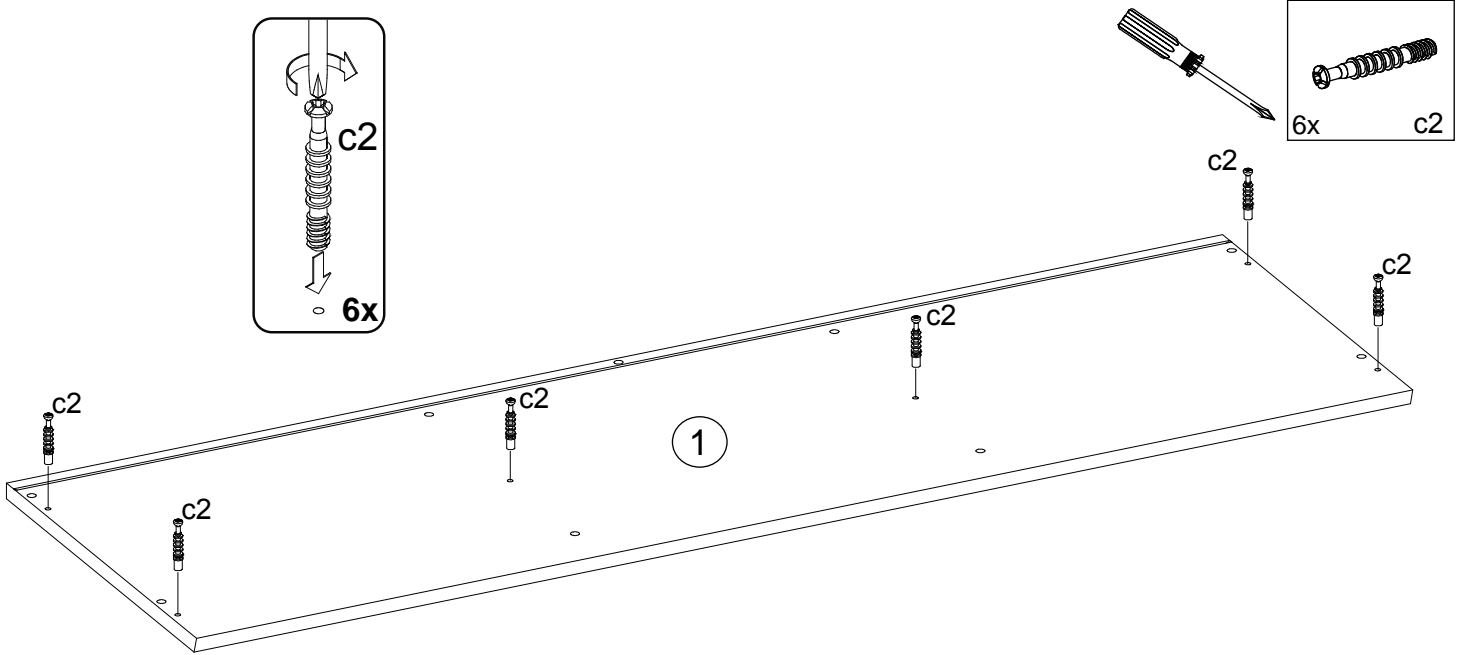

C

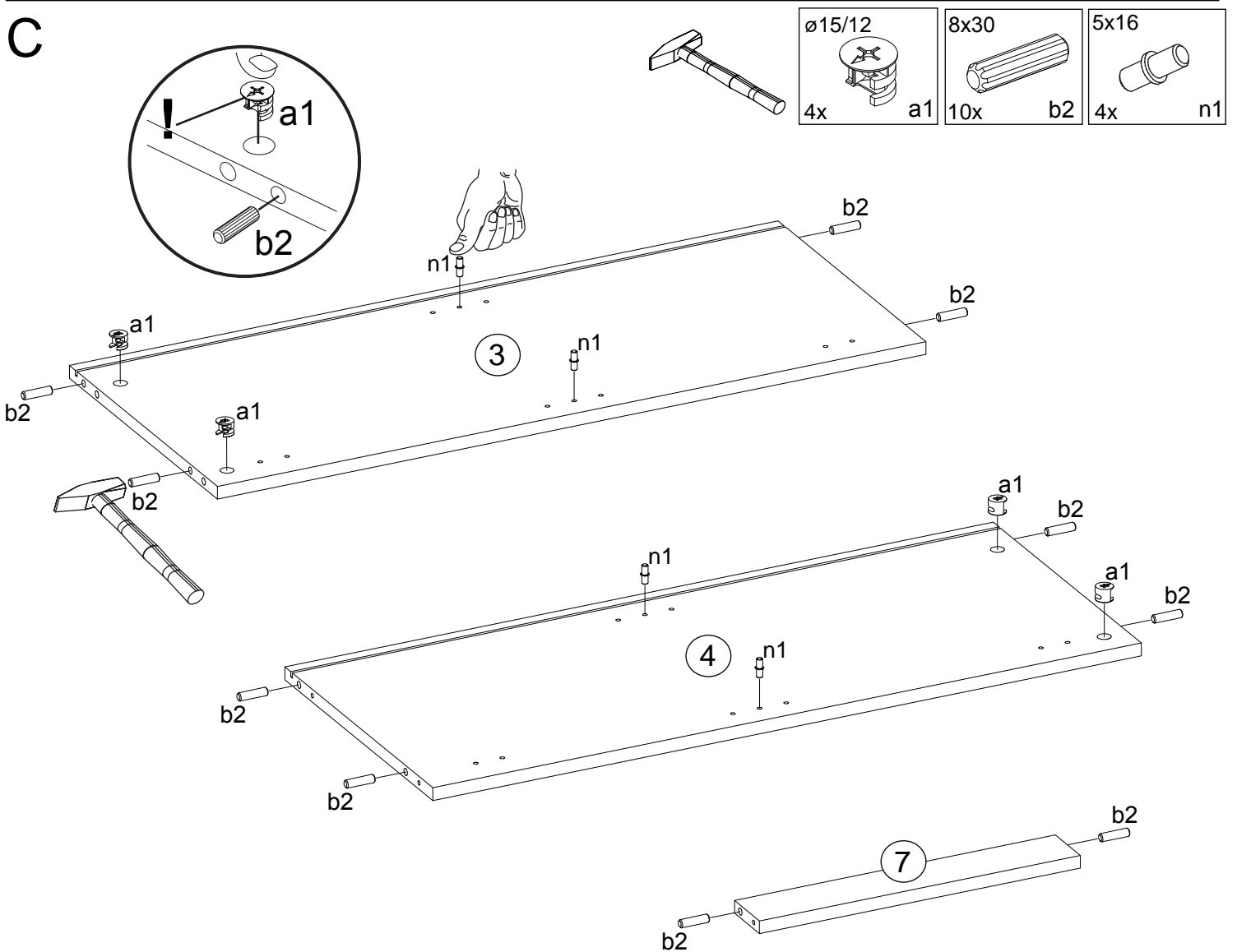

D

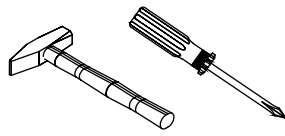

$\varnothing 15/12$ 2x a1	8x30 8x b2	5,9x9,7 4x e4	310x15x9 mm 2x i5	5x16 8x n1
----------------------------------	-------------------	----------------------	--------------------------	-------------------

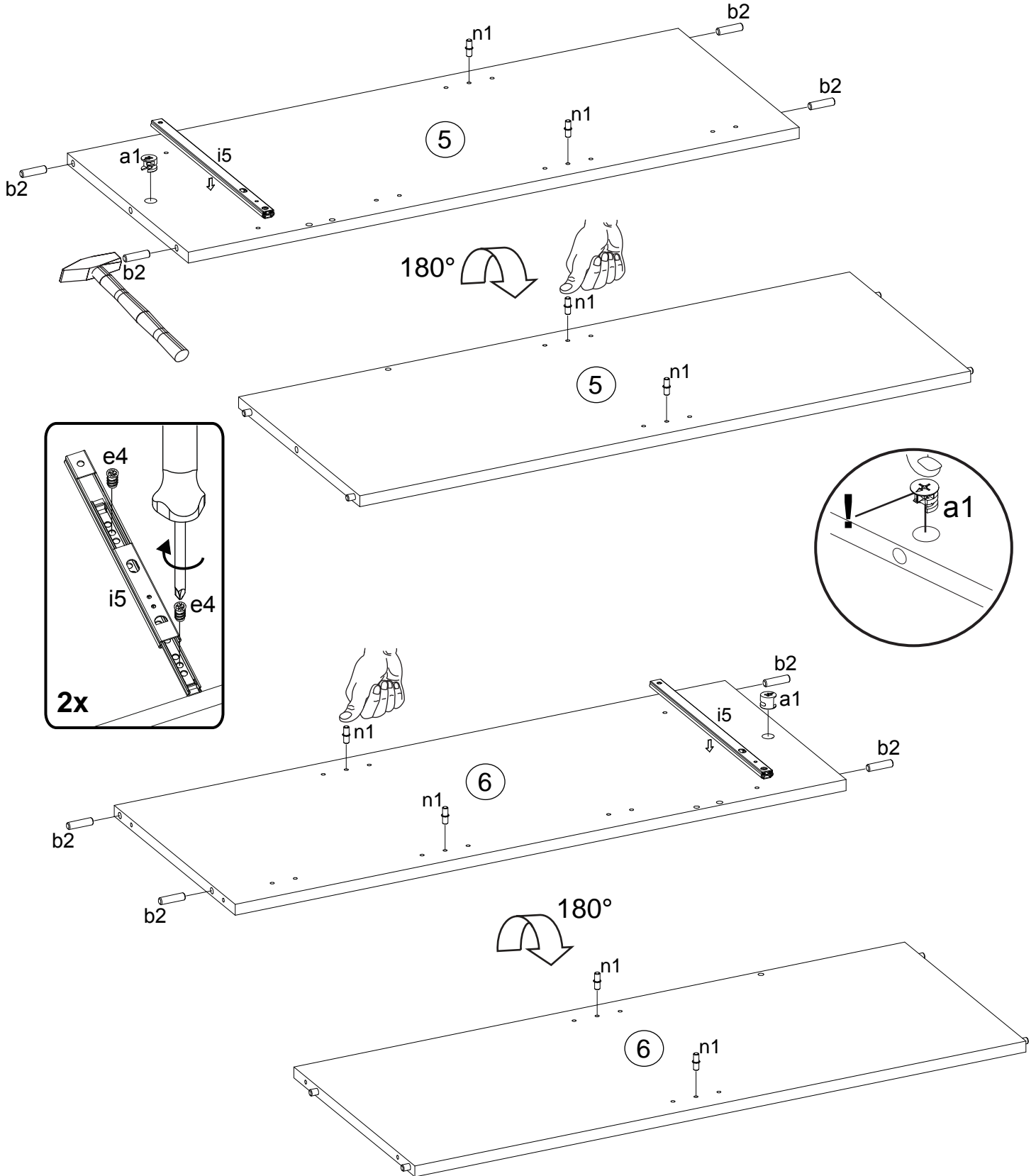

G

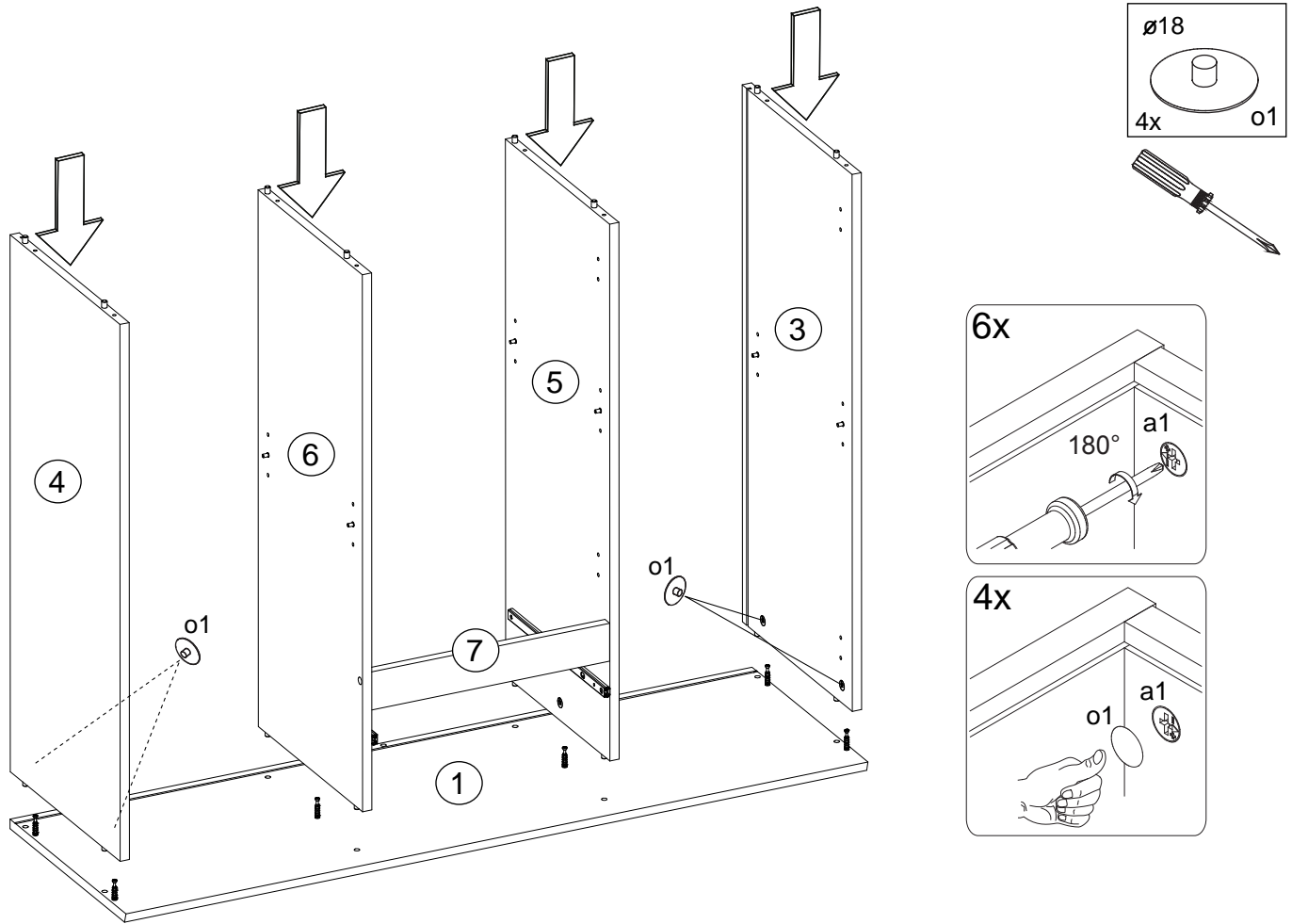

H

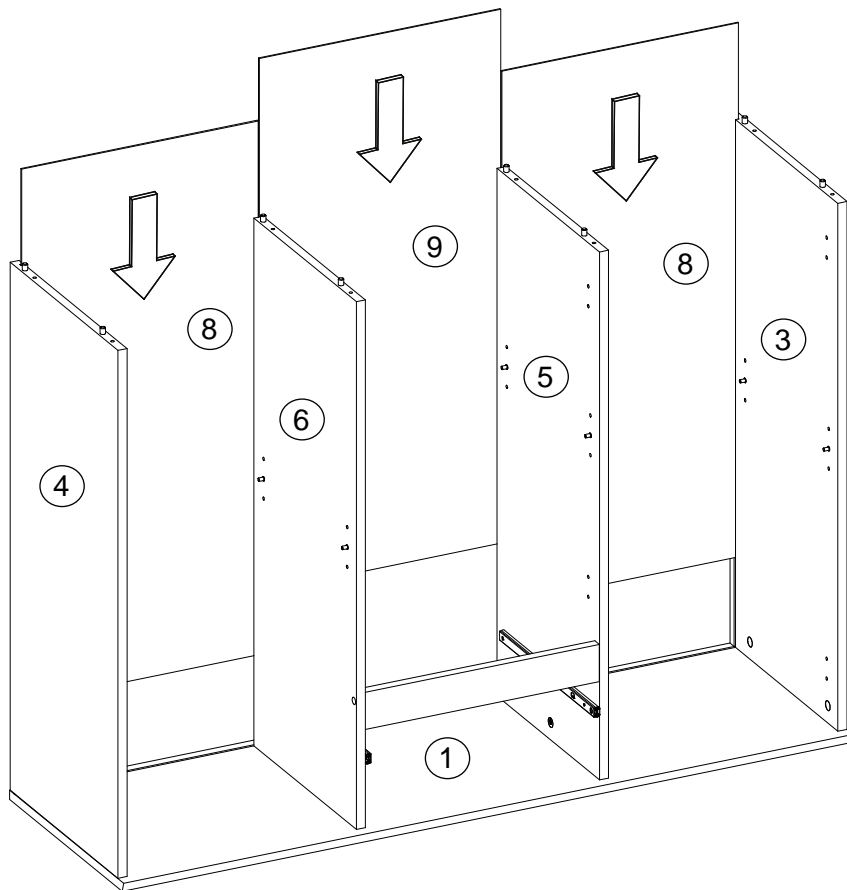

I

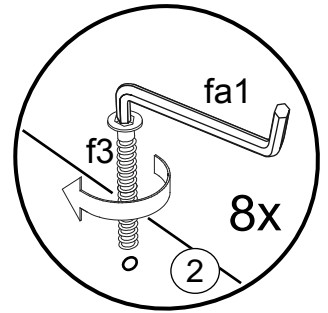
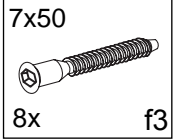
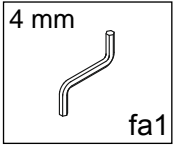
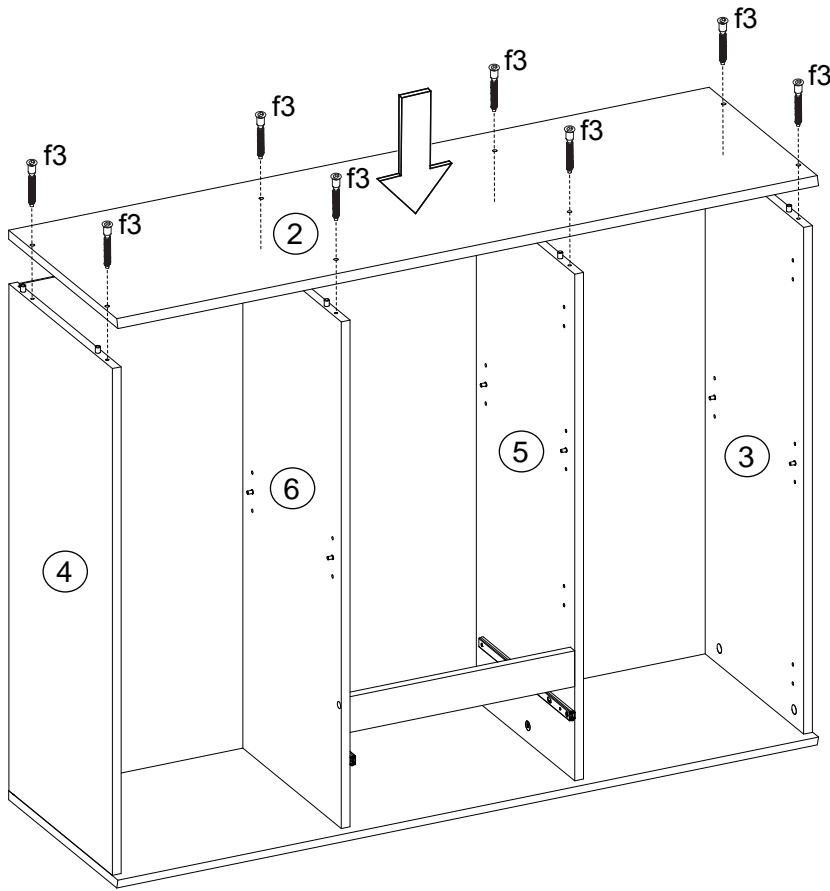

J

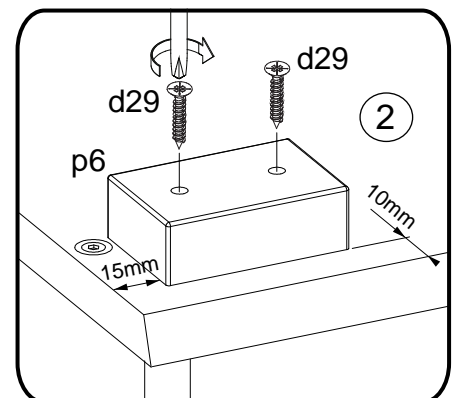
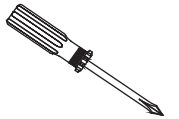
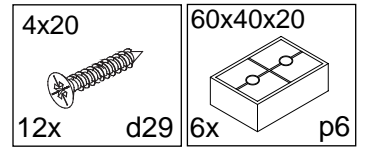
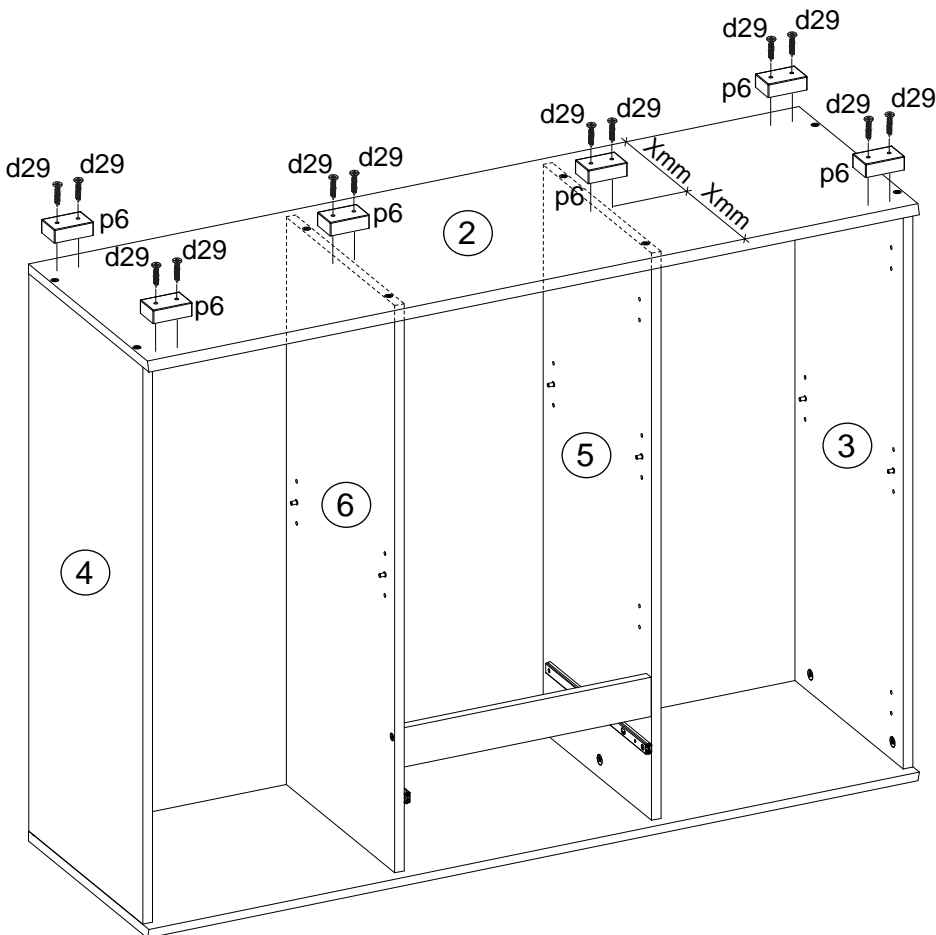

K

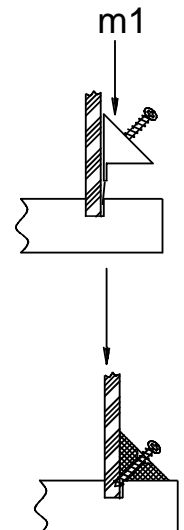
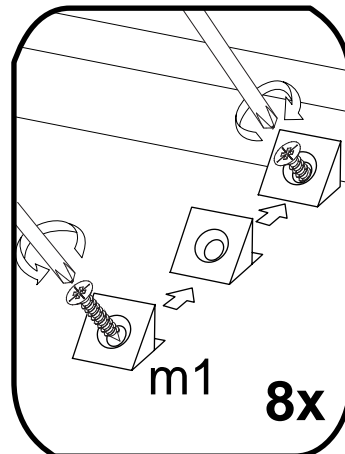
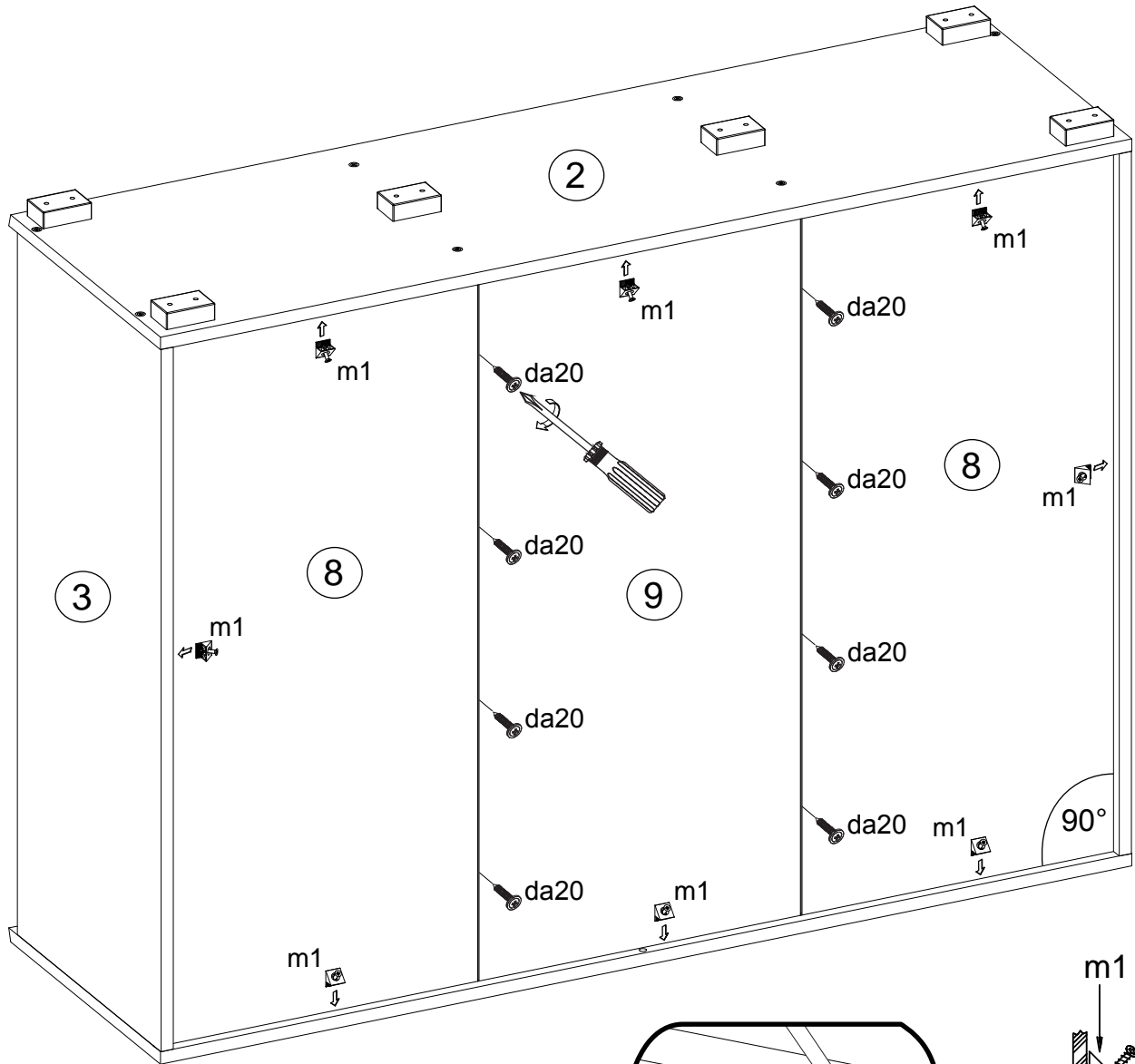
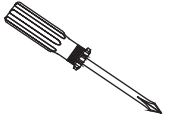
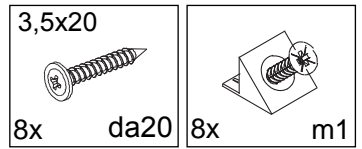



VLS01B/137

L Le meuble doit être fixé au mur!
 Das Möbel muss an der Wand befestigt werden!
 This unit must be secured to a wall using suitable fixing (not supplied)

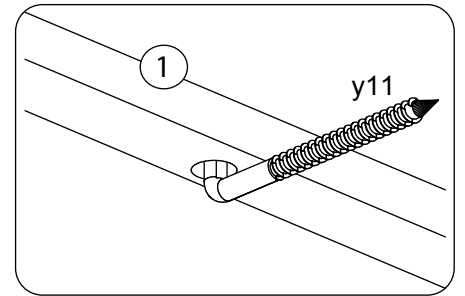
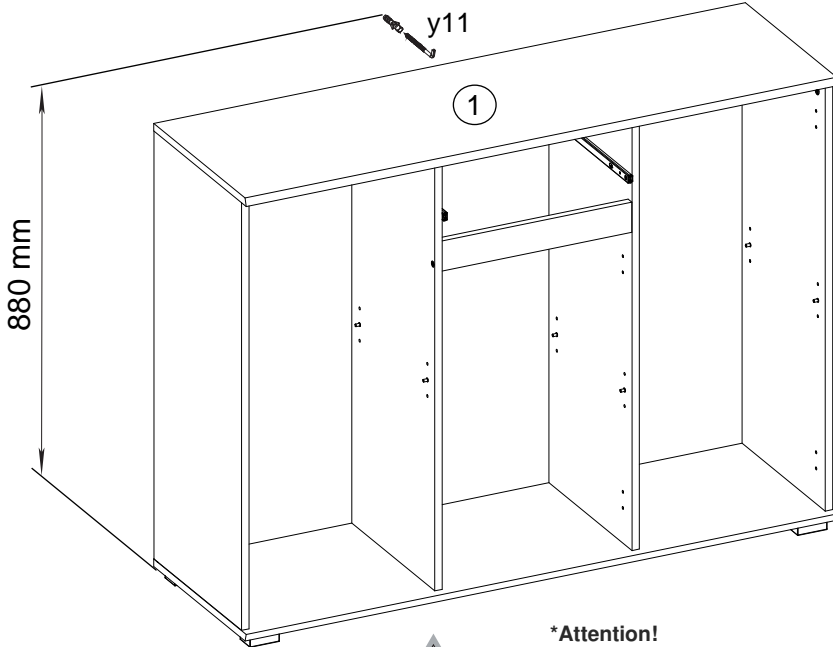
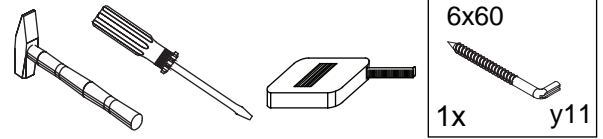

***Attention!**
 Veuillez-vous informer sur le type de cheville et vis approprié à la nature de votre mur.

***Achtung!**
 Informieren Sie sich vor der Wandmontage über das geeignete Montagematerial für Ihre Wand!

***Caution!**
 Please inform yourself about mounting material suitable for your wall before mounting.

M

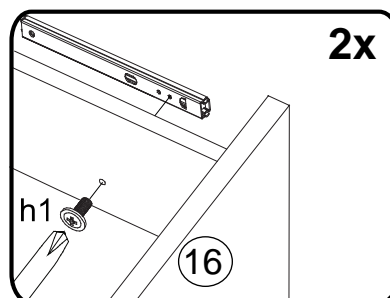
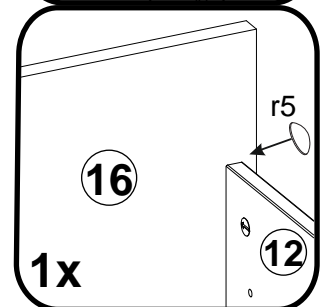
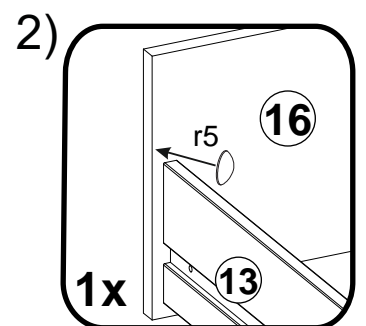
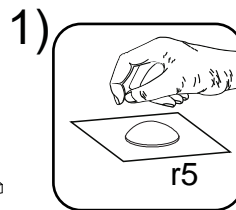
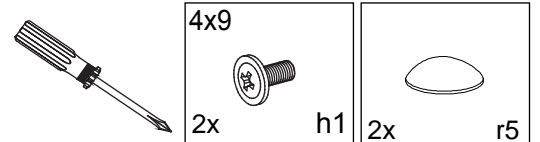
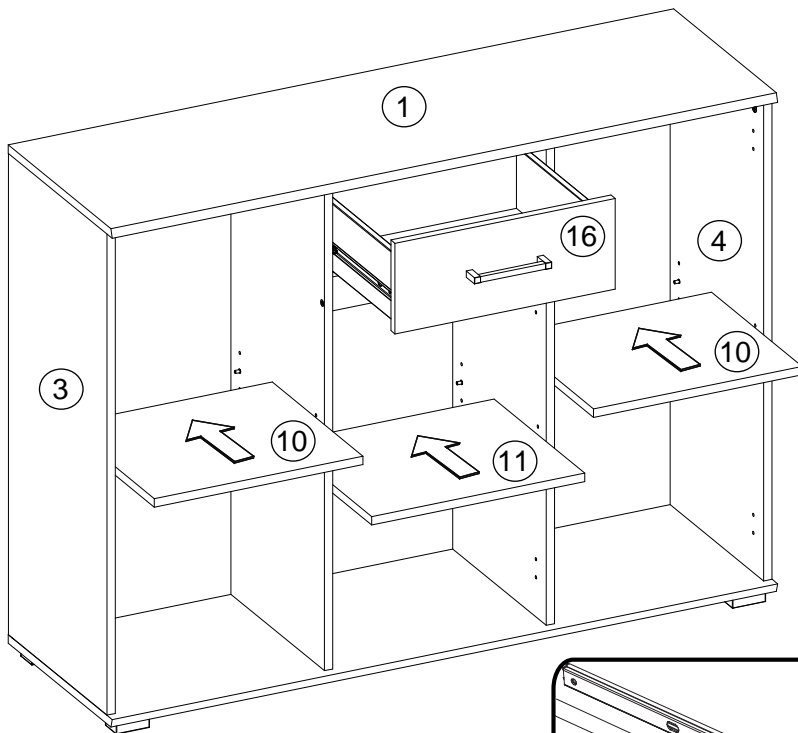

N

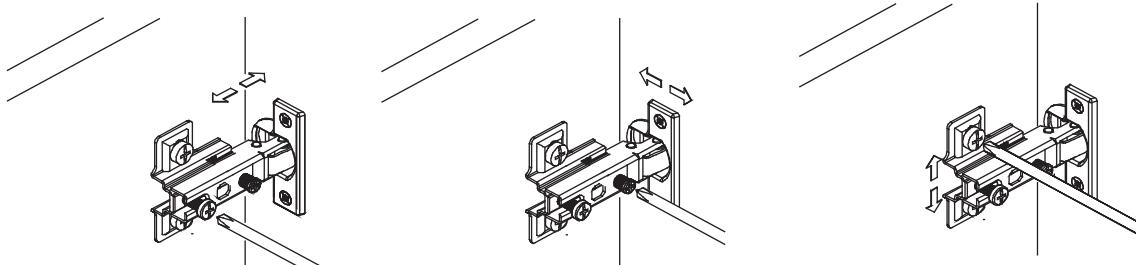
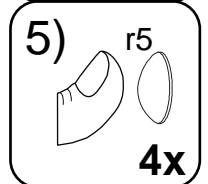
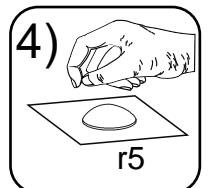
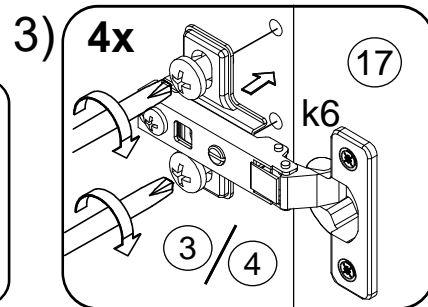
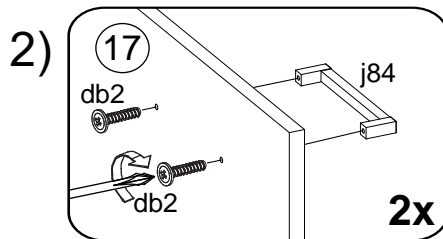
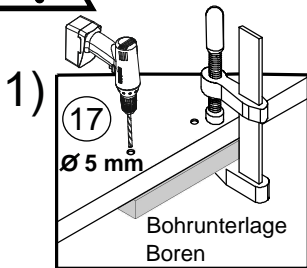
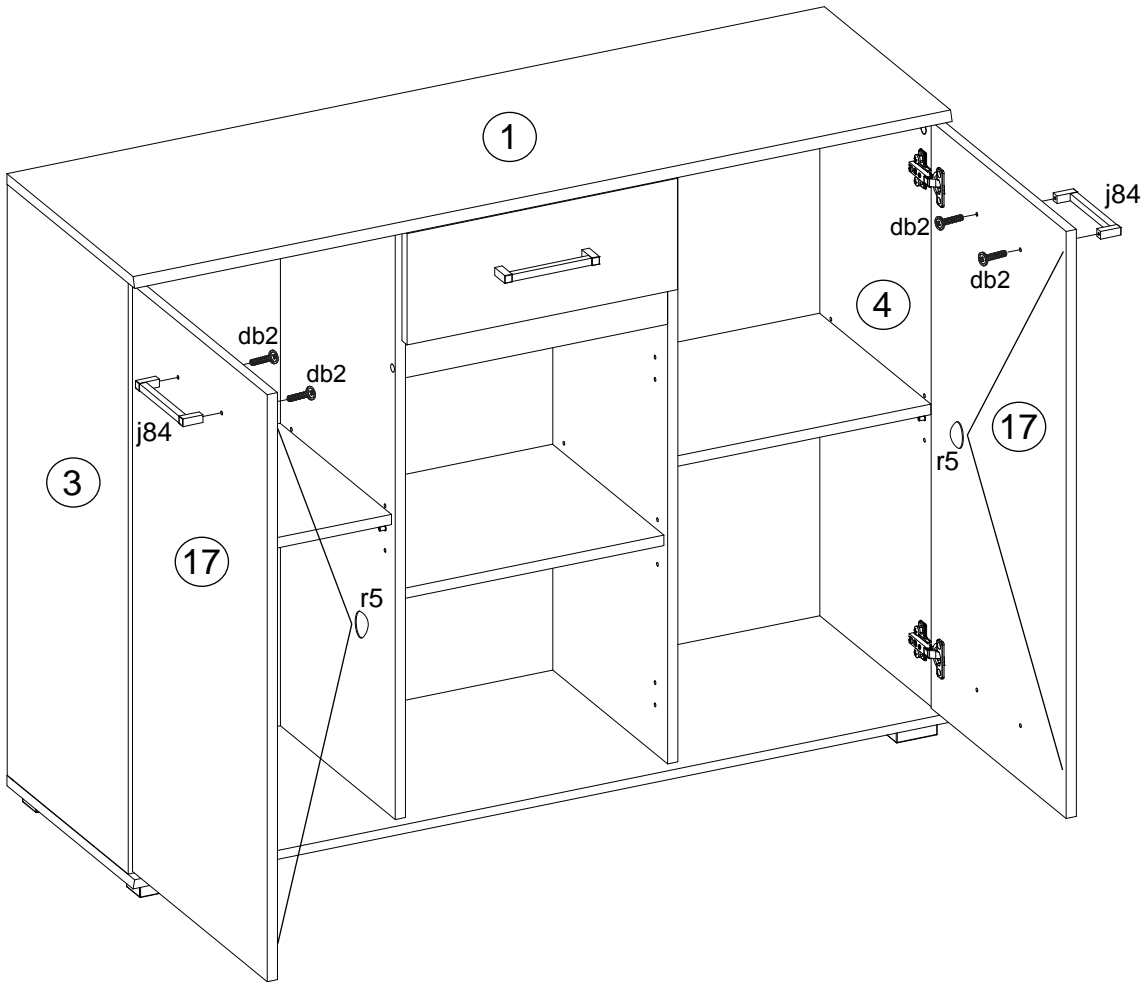
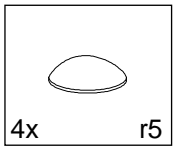
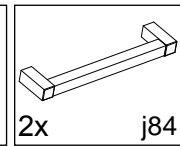
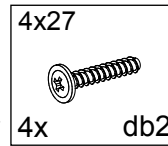
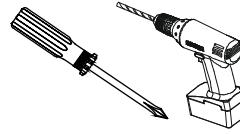

O

L

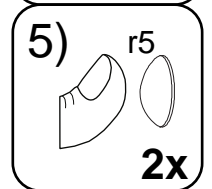
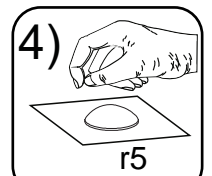
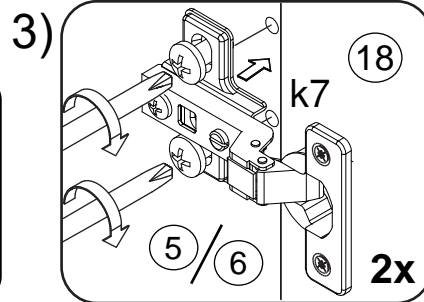
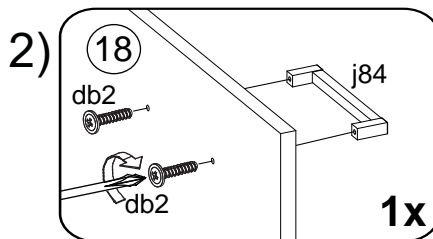
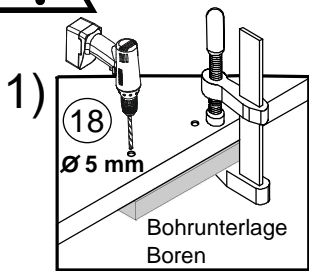
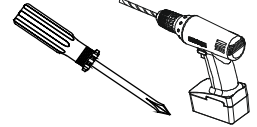
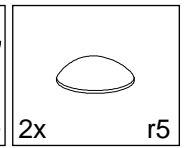
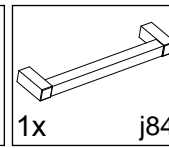
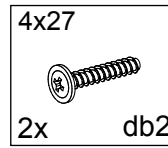
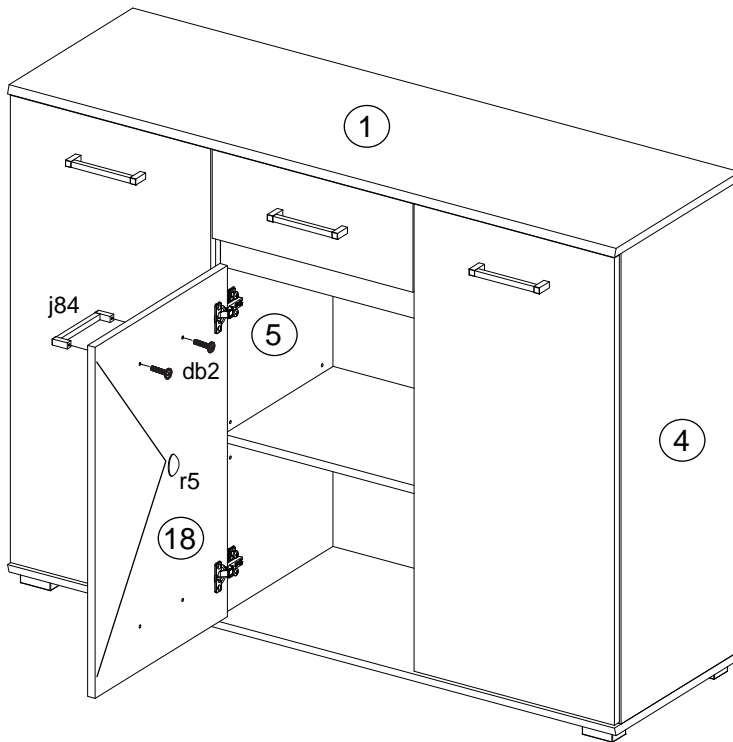

R

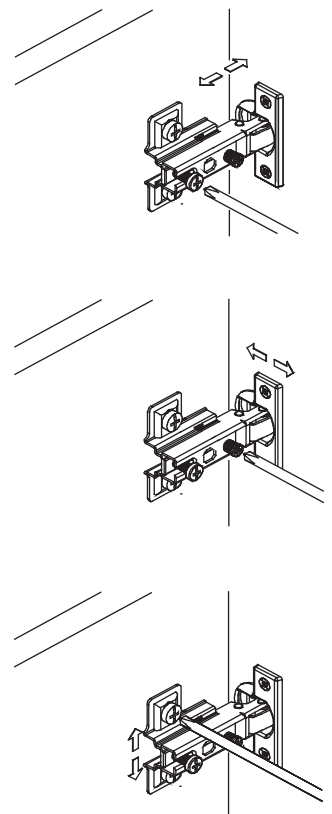
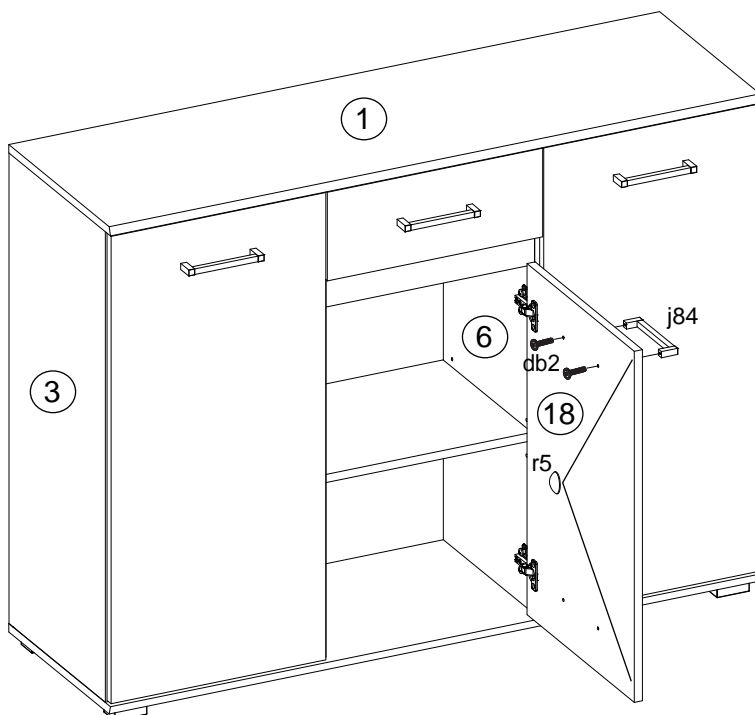



- Ⓓ Das Möbel muss an der Wand befestigt werden!
- Ⓔ Please ensure to mount the furniture to the wall!
- Ⓕ Les meubles doivent être fixés au mur!
- Ⓝ Het meubel moet aan de wand worden vastgemaakt!
- Ⓔ El mueble se tiene que fijar a la pared!
- Ⓡ Mebel należy przymocować do ściany!



- Ⓓ Informieren Sie sich vor der Wandmontage über das geeignete Montagematerial!
- Ⓔ Please get informed on suitable assembly materials before commencing the wall-mounting!
- Ⓕ Renseignez-vous sur le matériel de montage approprié avant le montage mural!
- Ⓝ Informeer u voor de wandmontage over het geschikte montagematerieel!
- Ⓔ Infórmese antes del montaje en la pared del material apropiado de montaje!
- Ⓡ Przed montażem na ścianie upewnij się, jaki jest potrzebny właściwy materiał montażowy!



- Ⓓ Beschaffen Sie sich das angemessene Material zur Wandbefestigung!
- Ⓔ Please obtain suitable wall-mounting materials!
- Ⓕ Procurez-vous le matériel approprié pour le montage mural!
- Ⓝ Verschaf u het adequate materieel voor de wandbevestiging!
- Ⓔ Procúrese el material adecuado para la fijación a la pared!
- Ⓡ Zakup odpowiedni materiał do przymocowania na ścianie!



- Ⓓ Lassen Sie die Wandbefestigung von einer fachkundigen Person vornehmen!
- Ⓔ Ensure all wall-mounting is carried out by competent personnel!
- Ⓕ Faites effectuer le montage mural par une personne compétente!
- Ⓝ Laat de wandbevestiging door een professional uitvoeren!
- Ⓔ Deje que la fijación a la pared la haga un profesional!
- Ⓡ Zlec przymocowanie do ściany odpowiednio doświadczonej osobie!

- Ⓡ Мебель должна крепиться к стене!
- Ⓓ Il mobile deve essere fissato alla parete!
- Ⓡ A bútor a falon rögzítendő!
- Ⓓ O móvel tem que ser fixado na parede!
- Ⓔ Nábytek musí být připevněn ke stěně!

- Ⓡ Перед тем, как крепить мебель к стене, получите информацию о подходящем крепежном материале!
- Ⓓ Prima del fissaggio alla parete, informarsi sul materiale di montaggio adatto!
- Ⓡ A falra szerelés előtt tájékozódjon, hogy ehhez milyen szerelőanyagok szükségesek!
- Ⓓ Antes da montagem na parede, informe-se sobre o material de montagem adequado!
- Ⓔ Informujte se o vhodném montážním materiálu před montáží na stěnu!

- Ⓡ Приобретите соответствующий материал для крепления к стене!
- Ⓓ Procurarsi il materiale opportuno per il fissaggio alla parete!
- Ⓡ Szerezze be a falra szereléshez szükséges, megfelelő anyagokat!
- Ⓓ Obtenha o material adequado para a montagem na parede!
- Ⓔ Opatřte si vhodný materiál pro montáž na stěnu!

- Ⓡ Поручите выполнение работ по креплению к стене специалисту!
- Ⓓ Far effettuare il fissaggio alla parete ad un esperto!
- Ⓡ A bútor falra rögzítését végeztesse ehhez értő személlyel!
- Ⓓ A montagem na parede deve ser executada por uma pessoa competente!
- Ⓔ Montáž na stěnu nechte provést odborně způsobilou osobou!

